

DRV2603 ERM/LRA Haptic Driver Evaluation Kit

The DRV2603 is a haptic driver designed to control Linear Resonant Actuators (LRA) and Eccentric Rotating Mass (ERM) motors. The DRV2603 provides many features which help eliminate the design complexities of haptic motor control including reduced solution size, high efficiency output drive, simplified control signaling, quick device startup, and auto-resonance frequency tracking.

The DRV2603EVM-CT Evaluation Module (EVM) is a complete demo and evaluation platform for the DRV2603. The kit includes a microcontroller, linear actuator, eccentric rotating mass motor, samples waveforms and capacitive touch buttons which can be used to completely demonstrate and evaluate the DRV2603.

This document contains instructions for setup and operation of the DRV2603EVM-CT, as well as an in-depth description and examples of haptic waveforms for LRA and ERM actuators.

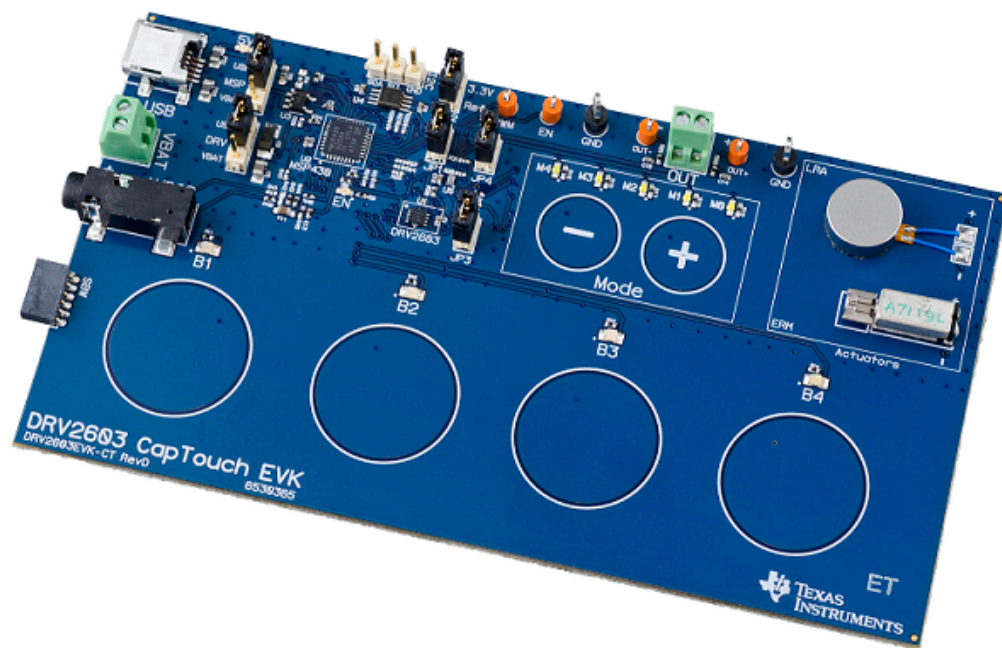

Evaluation Kit Contents:

- DRV2603EVM-CT Demo and Evaluation board
- Mini-USB Cable

Needed for programming and advanced configuration:

- Code Composer Studio™ (CCS) or IAR Embedded Workbench IDE for MSP430
- EZ430-F2013, MSP430 LaunchPad (MSP-EXP430G2), or MSP430-FET430UIF hardware programming tool
- DRV2603EVM-CT Firmware

Code Composer Studio is a trademark of Texas Instruments.
I²C is a trademark of N.B.X Corporation.

Contents

1	Getting Started	3
	1.1 Evaluation Module Operating Parameters	4
	1.2 Quick Start Board Setup	4
2	DRV2603 Demonstration Program	5
	2.1 Modes and Effects Table	5
	2.2 Description of the Modes	5
3	Hardware Configuration	7
	3.1 Input and Output Overview	7
	3.2 Power Supply Selection	8
	3.3 Using an External Actuator	8
	3.4 PWM Input Source	9
	3.5 Enable Pin Source	10
	3.6 LRA/ERM Mode Source	11
4	Measurement and Analysis	12
	4.1 Output Measurements	12
5	MSP430 Control and Firmware	13
	5.1 Additional Hardware Modes	13
	5.2 Modifying or Reprogramming the Firmware	15
	5.3 MSP430 Pin-Out	16
6	Schematic	17
7	Layout	18
8	Bill of Materials	21

List of Figures

1	Board Diagram	3
2	LRA Auto-Resonance Off	6
3	LRA Auto-Resonance On	6
4	LRA Click without Braking	6
5	LRA Click with Braking	6
6	LRA Click and Release Effect	6
7	LRA Scroll Wheel Effect	6
8	Terminal Block and Test Points	8
9	External PWM Input	9
10	External Enable	10
11	Hardware Select Actuator Mode	11
12	Terminal Block and Test Points	12
13	DRV2603 Unfiltered Waveform	12
14	DRV2603 Filtered Waveform	12
15	Measuring the DRV2603 Output with a Digital Low-pass Filter	13
16	Measuring the DRV2603 Output Signal with an Analog Low-pass Filter	13
17	X-Ray Top View	18
18	Top Copper	18
19	Layer 2 Copper	19
20	Layer 3 Copper	19
21	Bottom Copper	20

List of Tables

1	Mode and Effects Table	5
2	Hardware Overview	7
3	Binary Counting Modes	14

1 Getting Started

The DRV2603 can be used as a demonstration or evaluation tool. When the DRV2603EVM-CT Evaluation Module is powered on, a demo application automatically starts. To power the board, connect the DRV2603EVM-CT to an available USB port on your computer using the included mini-USB cable. The demo begins with a board power-up sequence and then will enter the demo effects mode. The four larger buttons (B1-B4) can be used to sample haptic effects using both the ERM and LRA motor in the top right corner. The two smaller mode buttons (“-”, “+”) are used to change between the different sets of effects. See the [DRV2603 Demonstration Program](#) section for a more detailed description of the demo application.

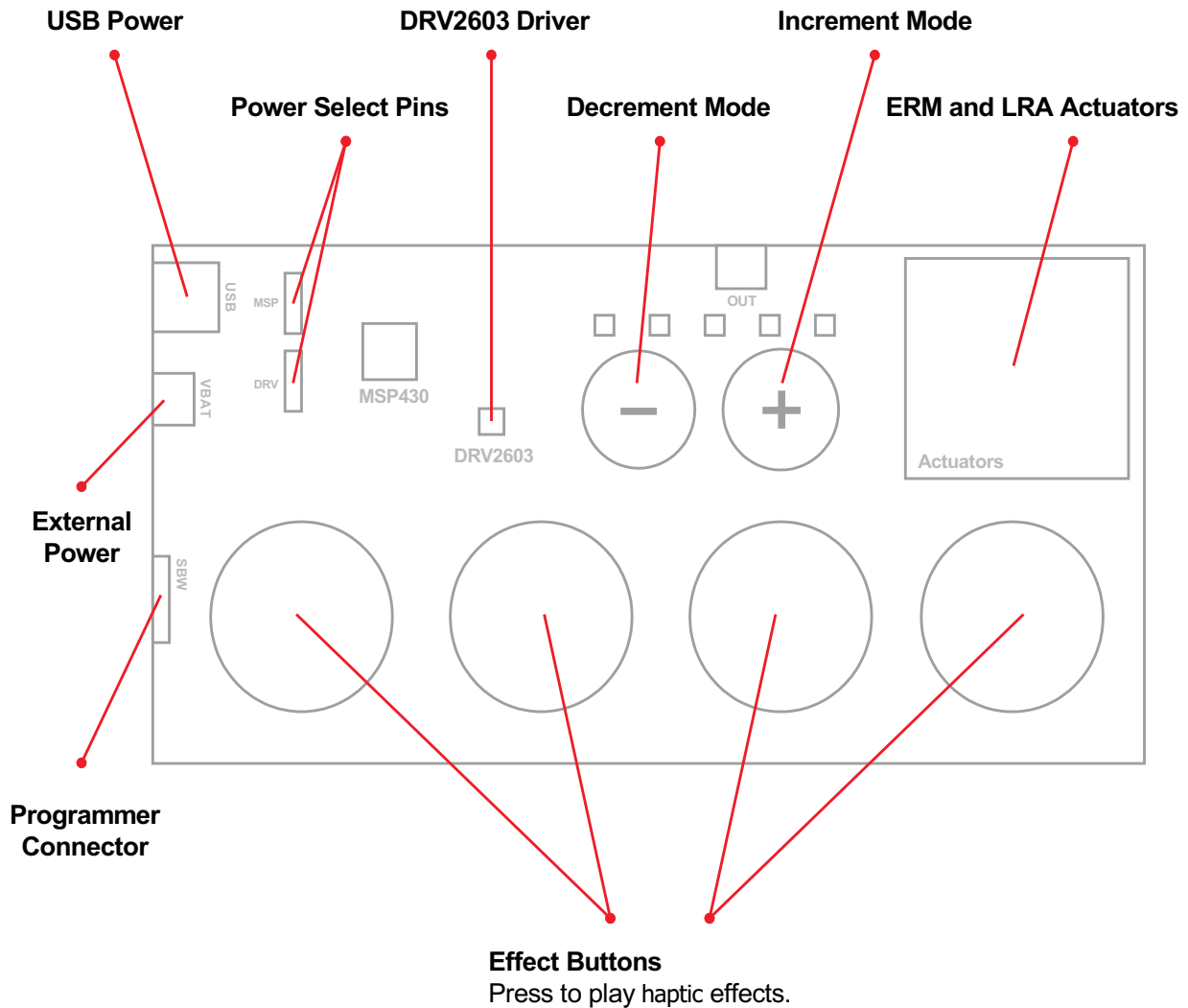

Figure 1. Board Diagram

1.1 Evaluation Module Operating Parameters

The following table lists the operating conditions for the DRV2603 on the evaluation module.

Parameter	Specification
Supply voltage range	2.5V to 5.2V
Power-supply Current Rating	400mA
External PWM Voltage, V_{PWM} (optional)	1.8V to V_{DD}

1.2 Quick Start Board Setup

The DRV2603EVM-CT firmware contains haptic effects which showcase the features and benefits of the DRV2603. Follow the instructions below to begin the demo.

1. Out of the box, the jumpers are set to begin demo mode using USB power. The default jumper settings can be found in the table below.

Jumper	Default Position	Description
JP1	Shorted	Connect MSP430 PWM output to DRV2603 PWM input
JP2	Shorted	3.3V reference for I ² C
JP3, JP4	Shorted	Connect on-board actuators to DRV2603
MSP	USB to MSP	Select USB (5V) or VBAT power for the MSP430
DRV	USB to DRV	Select USB (5V) or VBAT power for the DRV2603

2. Connect the included mini-USB cable to the USB connector on the DRV2603EVM-CT board.
3. Connect the other end of the USB cable to an available USB port on a computer, USB charger, or USB battery pack.
4. If the board is powered correctly the four colored LEDs will light up, the four mode LEDs will flash, and the LRA and ERM will play an effect, indicating the board has been successfully initialized.

2 DRV2603 Demonstration Program

The DRV2603EVM-CT demo contains haptic effects which showcase the features and benefits of the DRV2603. The sections below provide a detailed description of the included effects.

2.1 Modes and Effects Table

The effects preloaded on the DRV2603EVM-CT are listed in [Table 1](#). The modes are selected using the “+” and “-” mode buttons in the center of the board. The current mode can be identified by the white LEDs directly above the mode buttons. Buttons B1-B4 trigger the effects listed in the description column and will change based on the selected mode.

Table 1. Mode and Effects Table

Mode	Button	Description	Actuator Mode
Mode 0 LEDs Off	B1	Ramp-up and click	LRA
	B2	Click and Ramp-down	(Auto-Resonance On)
	B3	Ramp-up and click	ERM
	B4	Click and Ramp-down	
Mode 1 LED M4 On	B1	LRA Alert (Buzz)	LRA (Auto-Resonance On)
	B2	LRA Alert (Buzz)	LRA (Auto-Resonance Off)
	B3	ERM Alert (Buzz)	ERM
	B4	LED Flash (Visual Alert Only)	–
Mode 2 LED M3 On	B1	Click with braking	LRA (Auto-Resonance On)
	B2	Click no braking	
	B3	Double-click with braking	
	B4	Double-click no braking	
Mode 3 LED M2 On	B1	Keyboard Click (Click with braking)	LRA (Auto-Resonance On)
	B2	Spacebar Effect (Click and Release)	
	B3	Backspace Effect (Double-tick)	
	B4	Scroll Wheel Effect	
Mode 4 LED M1 On	B1	Click with braking	ERM
	B2	Click no braking	
	B3	Double-click with braking	
	B4	Double-click no braking	
Mode 5 LED M0 On	B1	Concentration Game	ERM and LRA (Auto-Resonance On)
	B2		
	B3		
	B4		

2.2 Description of the Modes

The modes above were created to showcase various benefits of the DRV2603. See the description of each mode below for more details.

2.2.1 Mode 0 – Ramp and Fade Waveforms

Mode 0 is ramp effects which demonstrate transitional effect capabilities of both LRAs and ERMs.

2.2.2 Mode 1 – Buzz and Alerts

Mode 1 demonstrates an LRA with auto-resonance on, an LRA with auto-resonance off, and an ERM. Compare the difference in strength between the LRA with and without auto-resonance.

Figure 2 and Figure 3 compare the acceleration (in blue) between a driver without auto-resonance detection and a driver with auto-resonance detection.

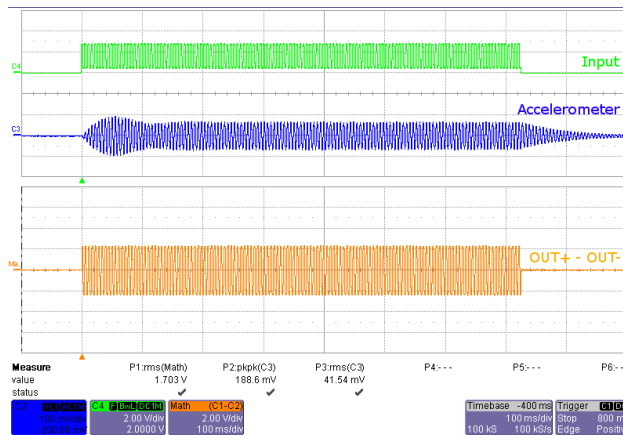

Figure 2. LRA Auto-Resonance Off

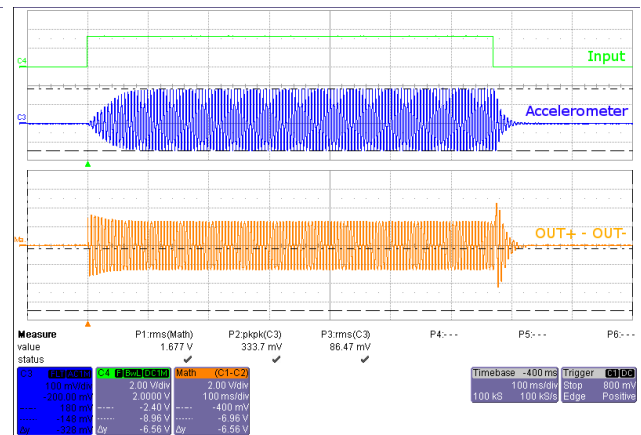

Figure 3. LRA Auto-Resonance On

2.2.3 Mode 2 – LRA Clicks

Mode 2 showcases LRA clicks and double clicks. Notice the difference in length of the click with braking and without braking. Then compare the double clicks and notice the event separation is only possible with braking.

Figure 4 and Figure 5 show the difference between a click with braking and a click without braking. Notice the acceleration (in blue) is much longer when braking is not applied.

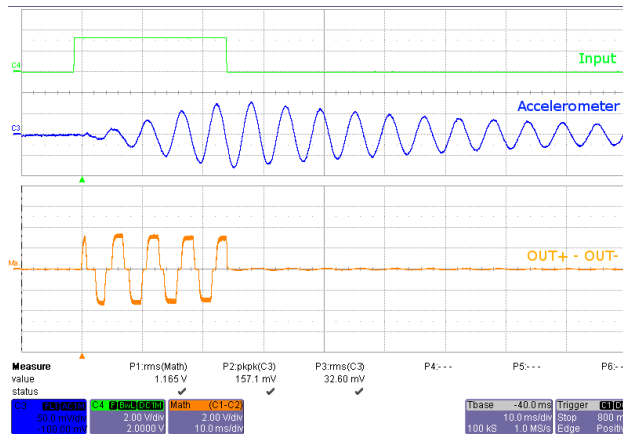

Figure 4. LRA Click without Braking

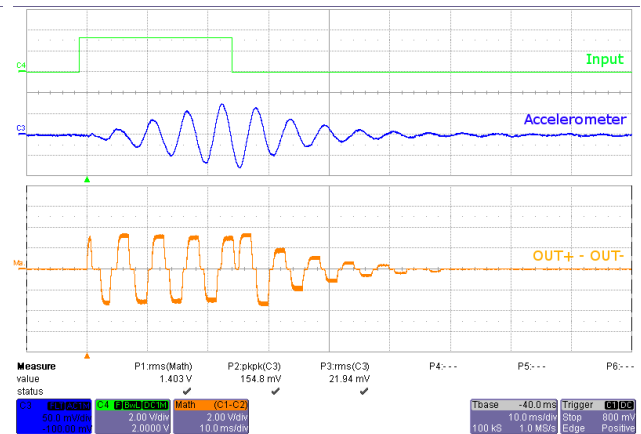
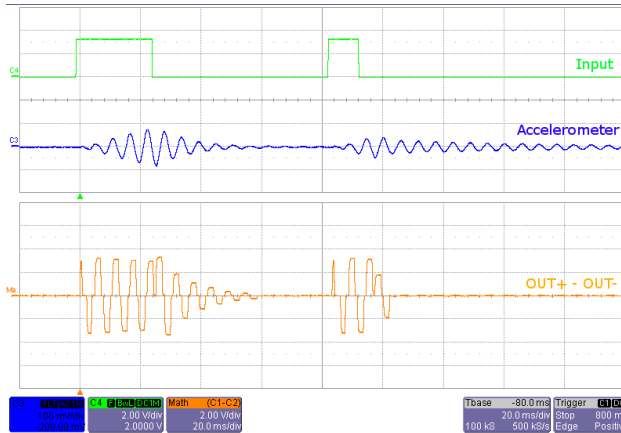
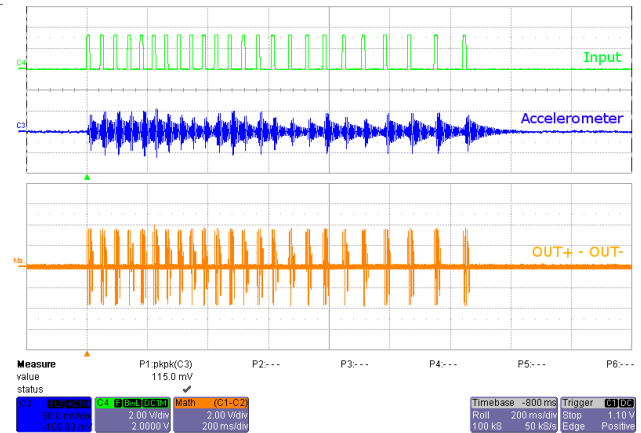

Figure 5. LRA Click with Braking

2.2.4 Mode 3 – User Interface Effects

Mode 3 showcases LRA user interface effects.

1. Button 1 – Basic click effect
2. Button 2 – Click and Release effect – when holding the board press this button. The button will click when pressed down and bump when released giving a full button effect.
3. Button 3 – Double tick effect – the double tick effect can be used for a backspace key or some other special function key.
4. Button 4 – Scroll wheel effect – press this button while holding the board and feel the scroll-like effect imitating a flick or scroll gesture.

Figure 6. LRA Click and Release Effect

Figure 7. LRA Scroll Wheel Effect

2.2.5 Mode 4 – ERM Clicks

Mode 4 showcases ERM clicks and double clicks. Similarly to the LRA, compare the click with braking and without braking and notice the sharper feel with braking.

2.2.6 Mode 5 – Concentration Game

Mode 5 is a game that incorporates the various LRA and ERM effects. This can be used to demonstrate haptics in a real application.

To begin playing Concentration:

1. Press any of the large effect buttons.
2. The game will then count down.
3. Once the countdown completes, a button will light and an effect will play.
4. Repeat the pattern by pressing the same button.
5. After each successfully repeated pattern, the board will repeat the same pattern and add one additional button to the sequence.

3 Hardware Configuration

The DRV2603EVM-CT is very flexible and can be used to completely evaluate the DRV2603. The following sections list the various hardware configurations.

3.1 Input and Output Overview

The DRV2603EVM-CT allows complete evaluation of the DRV2603 through test points, jacks and connectors. [Table 2](#) gives a brief description of the hardware.

Table 2. Hardware Overview

Signal	Description	I/O
PWM	External DRV2603 PWM input	Input / Observe
EN	External DRV2603 enable control	Input / Observe
OUT+ / OUT-	Filtered output test points for observation, connect to oscilloscope or measurement equipment	Output
OUT	Unfiltered output terminal block, connect to actuator	Output
USB	USB power (5V)	Input
VBAT	External Supply Power (2.5V-5.2V)	Input
SBW	MSP430 programming header	Input / Output
I ² C	MSP430 I ² C™ bus	Input / Output

Table 2. Hardware Overview (continued)

Signal	Description	I/O
Audio	The audio jack is connected to an ADC on the MSP430. This is used for audio-to-haptics conversion using special software on the MSP430.	Input

Hardware configuration details can be found in the following sections.

3.2 Power Supply Selection

The DRV2603EVM-CT can be powered by USB or an external power supply (VBAT). Jumpers “DRV” and “MSP” are used to select USB or VBAT for the DRV2603 and MSP430G2553, respectively. See the following table for possible configurations.

Supply Configuration	DRV	MSP	DRV2603 Supply Voltage ⁽¹⁾
USB – Both	USB	USB	5V
DRV2603 External Supply, MSP430 USB	VBAT	USB	VBAT
External Supply - Both	VBAT	VBAT	VBAT
USB with 3.3V LDO ⁽²⁾ - Both	USB	USB	3.3V (R4 = Short, R5 = Open)

⁽¹⁾ The DRV2603 supply must be on before operating the MSP430.

⁽²⁾ If a 3.3V DRV2603 supply voltage is preferred while using the USB as the power source, remove R5 and add a zero ohm resistor across R4.

3.3 Using an External Actuator

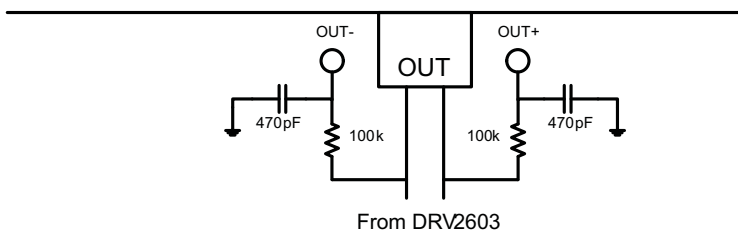

Figure 8. Terminal Block and Test Points

The DRV2603EVM-CT can be used with an external actuator. Follow the instructions below to attach an actuator to the "OUT" terminal block.

1. Remove jumpers JP3 and JP4, which will disconnect the on-board actuators from the DRV2603.
2. Attach the positive and negative leads of the actuator to the green “OUT” terminal block keeping in mind polarity.
3. Screw down the terminal block to secure the actuator leads.

It is important to use the green terminal block when connecting an external actuator. The "OUT+" and "OUT-" testpoints have low-pass filters and should only be used for oscilloscope and bench measurements.

3.4 PWM Input Source

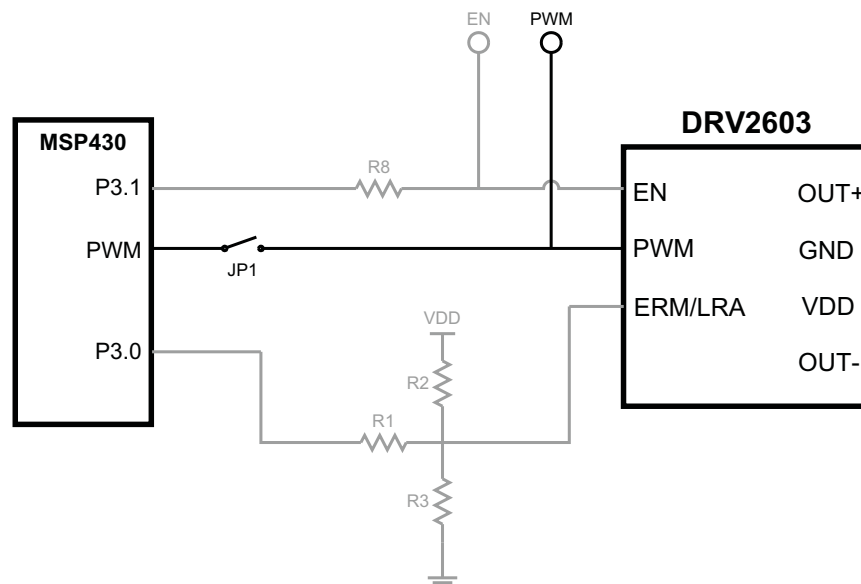

Figure 9. External PWM Input

The DRV2603 input signal can be driven by the on-board MSP430 PWM or an external PWM source. The input source is selected by shorting or disconnecting JP1.

JP1	PWM Source
Shorted	MSP430
Open	External PWM using PWM testpoint

To set the DRV2603 enable pin high while using an external PWM source:

1. Enter [Additional Hardware Modes](#) by holding the "+" button until the actuator buzzes and the mode LEDs blink.
2. Select Mode 3 (00011'b) using the increment mode button ("+").
3. In Mode 3, press one of the following buttons to enable the DRV2603.
 - B1 - disable the DRV2603
 - B2 - enable with LRA auto-resonance on
 - B3 - enable with LRA auto-resonance off
 - B4 - enable in ERM mode
4. If the DRV2603 is enabled, the "EN" LED will glow.

3.5 Enable Pin Source

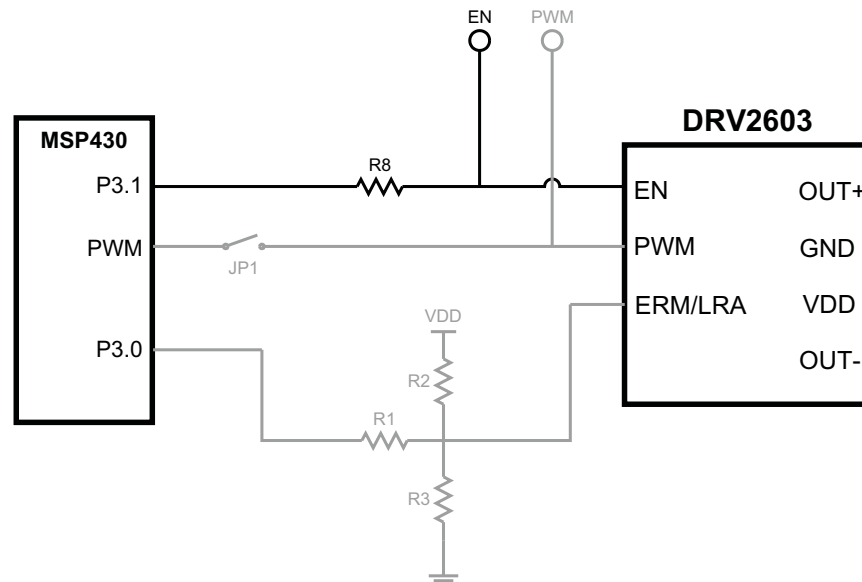

Figure 10. External Enable

The enable pin on the DRV2603 is controlled by the MSP430. To use an external control source or GPIO there are two options.

Using the [Additional Hardware Modes](#) in the MSP430 firmware, select "Mode 5" which will Hi-Z the MSP430 I/O enable control pin so it does not interfere with the external enable control source.

1. Enter [Additional Hardware Modes](#) by holding the "+" button until the actuator buzzes and the mode LEDs blink.
2. Select Mode 5 (00101'b) using the increment mode button ("+").
3. Connect the external control source to the EN test point at the top of the board.
4. In Mode 5, press one of the following buttons to Hi-Z the DRV2603 enable (EN) pin.
 - B1 - disable Hi-Z mode
 - B2 - Hi-Z MSP430 EN pin, select LRA auto-resonance on
 - B3 - Hi-Z MSP430 EN pin, select LRA auto-resonance off
 - B4 - Hi-Z MSP430 EN pin, select ERM mode

To physically disconnect the MSP430 from the DRV2603 enable pin:

1. Remove resistor R8 which disconnects the MSP430 from the DRV2603.
2. Connect the external control source to the EN test point at the top of the board.

3.6 LRA/ERM Mode Source

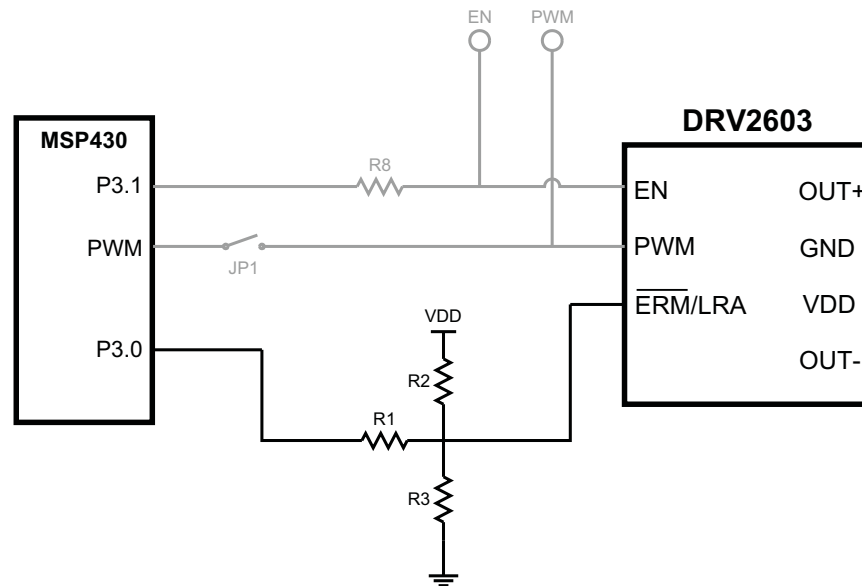

Figure 11. Hardware Select Actuator Mode

The DRV2603EVM-CT includes both an LRA and ERM actuator. By default, the MSP430 firmware will apply the appropriate logic voltage to the DRV2603 actuator select pin (LRA/ERM) and select the appropriate actuator using an on-board load switch (U5).

To manually select the on-board actuator using the MSP430 firmware:

1. Enter [Additional Hardware Modes](#) by holding the "+" button until the actuator buzzes and the mode LEDs blink.
2. Select Mode 3 (00011'b) using the increment mode button ("+").
3. In Mode 3, press one of the following buttons to enable the DRV2603 and select the appropriate actuator.
 - B1 - disable the DRV2603
 - B2 - select the on-board LRA and enable the DRV2603
 - B3 - select the on-board LRA and enable the DRV2603
 - B4 - select the on-board ERM and enable the DRV2603
4. If the DRV2603 is enabled, the "EN" LED will glow.

To manually set the actuator select pin using hardware, use resistors R1, R2, and R3 to configure the DRV2603 .

1. Remove resistor R1, which will disconnect the MSP430.
2. To select LRA mode, add a 0Ω resistor across R2 which will short the pin to VBAT.
3. To select ERM mode, add a 0Ω resistor across R3 which will short the pin to ground.

To manually select either the on-board ERM or LRA actuator using hardware:

1. Remove resistor R34 which will disconnect the MSP430.
2. To select the LRA, place a 0Ω resistor across R35.
3. To select the ERM, no additional resistors are needed.

Actuator Selection Resistor Configurations

Actuator Type	R1	R2	R3	R34	R35
ERM	Open	Open	0Ω	Open	Open
LRA	Open	0Ω	Open	Open	0Ω
External ERM	Open	Open	0Ω	X ⁽¹⁾	X ⁽¹⁾
External LRA	Open	0Ω	Open	X ⁽¹⁾	X ⁽¹⁾

⁽¹⁾ Does not matter

4 Measurement and Analysis

4.1 Output Measurements

The DRV2603 uses PWM modulation to create the output signal for both ERM and LRA actuators. To measure and observe the DRV2603 output waveform, connect an oscilloscope or other measurement equipment to the filtered output test points, “OUT+” and “OUT-“.

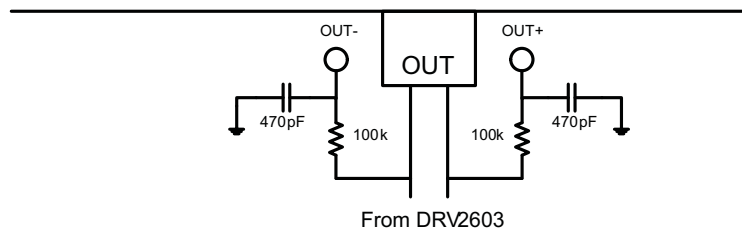

Figure 12. Terminal Block and Test Points

The DRV2603 drives LRA and ERM actuators using a 20kHz PWM modulated waveform, but only the frequencies around the LRA resonant frequency or the ERM DC drive voltage are relevant to the haptic actuator vibration. The higher frequency switching content does not contribute to the vibration strength of the actuator and can make it difficult to interpret the modulated output waveform on an oscilloscope. The oscilloscope image on the left shows the DRV2603 unfiltered waveform and the image on the right shows a filtered version used for observation and measurement.

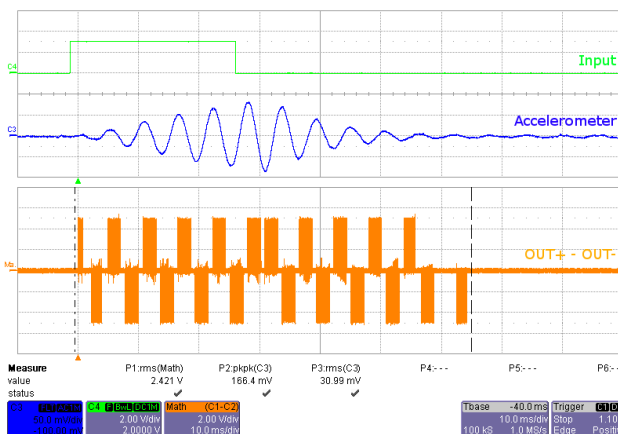

Figure 13. DRV2603 Unfiltered Waveform

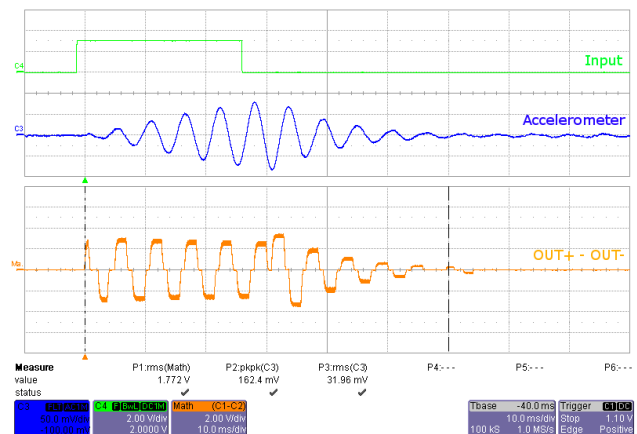

Figure 14. DRV2603 Filtered Waveform

To observe the modulated output waveform and ensure that the 20kHz switching waveform and associated harmonics are not captured, use either a digital or analog, low pass filter when viewing the output waveform. TI recommends using a 1st-order, low-pass filter with a cutoff between 1kHz and 3.5kHz.

Below are recommended output filters for use while measuring and characterizing the DRV2603. Certain oscilloscopes have a built-in digital, low-pass filter, so no external components are required.

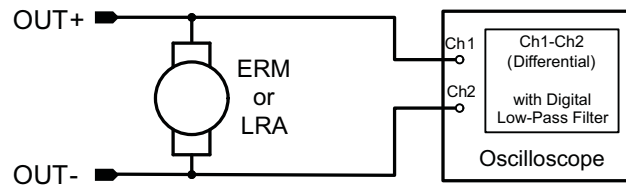

Figure 15. Measuring the DRV2603 Output with a Digital Low-pass Filter

An analog 1st order, low-pass, RC filter can also be used; however, care must be taken not to use a filter impedance that is too low. Low filter impedance can affect the back-EMF of the actuator and interfere with the auto-resonance detection algorithm. See the recommend values in [Figure 16](#).

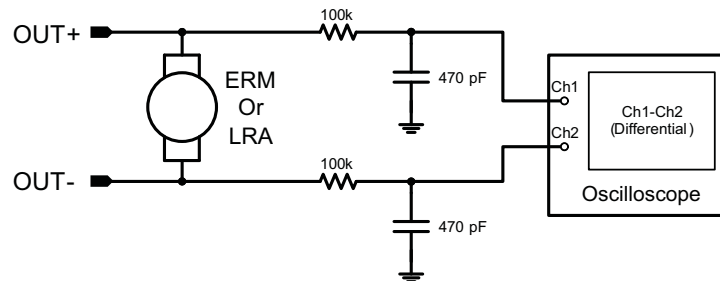

Figure 16. Measuring the DRV2603 Output Signal with an Analog Low-pass Filter

5 MSP430 Control and Firmware

The DRV2603EVM-CT is controlled by a programmable MSP430. This section contains information for programming and controlling the board using the MSP430.

5.1 Additional Hardware Modes

Additional modes are available on the DRV2603EVM-CT that provide increased board control and functionality. The additional modes are not available in “demo” mode, but can be access by switching to “binary counting mode”. In “binary counting mode” the mode LEDs count in binary (32 modes) rather than in “demo” mode format (only 6 modes including off).

5.1.1 Enter Binary Counting Mode

To enter “binary counting mode” and access the additional modes:

1. Press and hold the increment mode button (“+”) for approximately 3 seconds.
2. Release the button when the actuator buzzes and the mode LEDs flash.
3. Select from the “binary counting modes” using the “+” and “-” buttons.

All modes, including “demo” modes, are available in binary counting mode, see [Table 3](#) for a description.

5.1.2 Exit Binary Counting Mode

To exit “binary counting mode” and return to “demo” mode:

1. Press and hold the decrement mode button (“-”) for approximately 3 seconds.
2. Release the button when the actuator buzzes and mode LEDs flash.
3. Select from the “demo” modes using the “+” and “-” buttons.

5.1.3 Binary Counting Modes

Table 3 lists the modes available in “binary counting mode”. The same modes in “demo” mode are present in “binary counting mode”.

Table 3. Binary Counting Modes

Mode	Button	Description	Actuator Mode	Notes
Mode 0	Ramp and Clicks. See Table 1 Mode 0.			
Mode 1	Concentration Game. See Table 1 Mode 5.			
Mode 2	ERM Clicks. See Table 1 Mode 4.			
Mode 3 External PWM LEDs: 00011	B1	Disable Amplifier		External PWM - Apply an external PWM source to the PWM testpoint, use MSP430 for hardware configuration. Remove jumper JP1.
	B2	Enable DRV2603	LRA (Auto-Resonance On)	
	B3	Enable DRV2603	LRA (Auto-Resonance Off)	
	B4	Enable DRV2603	ERM	
Mode 4	LRA Keyboard and Mouse Effects. See Table 1 Mode 3.			
Mode 5 External PWM and External Enable LEDs: 00101	B1	Disable Amplifier		External PWM / External Enable - Apply an external PWM source and enable signal. Enable pin on MSP430 is Hi-Z. Remove jumper JP1.
	B2	Enable DRV2603	LRA (Auto-Resonance On)	
	B3	Enable DRV2603	LRA (Auto-Resonance Off)	
	B4	Enable DRV2603	ERM	
Mode 6 Life Test (LRA) LEDs: 00110	B1	Begin Life Test	LRA (Auto-resonance On)	Life Test (2 seconds on, 1 second off) - life test repeats infinite times and board must be powered down to stop. Increment / Decrement amplitude using B3 and B4. Test new amplitude using B2.
	B2	Test Buzz		
	B3	Decrease output voltage (+1 increment)		
	B4	Increase output voltage (+1 increment)		
Mode 7 Life Test Buzz (LRA) LEDs: 00111	B1	Begin Life Test	LRA (Auto-resonance On)	Life Test (Infinite Buzz) - board must be powered down to stop buzz. Increment / Decrement amplitude using B3 and B4. Test new amplitude using B2 before beginning life test.
	B2	Test Buzz		
	B3	Decrease output voltage (+1 increment)		
	B4	Increase output voltage (+1 increment)		
Mode 8	LRA Clicks. See Table 1 Mode 2			
Mode 9 Auto-resonance off frequency adjust LEDs: 01001	B1	Alert (Auto-resonance On)	LRA (Auto-resonance On)	Vary the auto-resonance off output frequency and see the change in vibration force over frequency. Compare B2 (auto-resonance off) with B1 (auto-resonance on).
	B2	Alert (Auto-resonance Off)	LRA (Auto-resonance Off)	
	B3	Decrease output frequency		
	B4	Increase output frequency		
Mode 10 Life Test Buzz (ERM) LEDs: 01010"	B1	Begin Life Test	ERM	Life Test (Infinite Buzz) - board must be powered down to stop buzz. Increment / Decrement amplitude using B3 and B4. Test new amplitude using B2 before beginning life test.
	B2	Test Buzz		
	B3	Decrease output voltage (+1 increment)		
	B4	Increase output voltage (+1 increment)		
Mode 16	Alerts. See Table 1 Mode 1.			

5.2 Modifying or Reprogramming the Firmware

The MSP430 firmware on the DRV2603EVM-CT can be modified or reprogrammed to create new haptic effects or behaviors. Find the latest firmware source code and binaries on TI.com. Follow the instructions below to modify or reprogram the DRV2603EVM-CT.

1. Purchase one of the following MSP430G2553 compatible programmers:
 - EZ430-F2013 (recommended)
 - MSP-EXP430G2 (recommended) - requires the additional purchase of a header for J4
 - Digi-Key: ED8650-ND
 - Mouser: 575-500201
 - MSP430-FET430UIF - requires a JTAG to Spy-Bi-Wire adapter (MSP-JTAGSBW if available)
2. Download and install Code Composer Studio (CCS) or IAR Embedded Workbench IDE.
3. Download the DRV2603EVM-CT source code and binaries from TI.com.
4. Connect the programmer to an available USB port.
5. Connect the programmer to the “SBW” header on the DRV2603EVM-CT.
6. In CCS,
 - (a) Open the project file by selecting Project > Import Existing CCS Project.
 - (b) Select Browse and navigate to the DRV2603EVM-CT project folder, then press OK.
 - (c) Select the checkbox next to the DRV2603EVM-CT project in the “Discovered projects” window and then press “Finish”.
 - (d) Before compiling, navigate to Project > Properties > Build > MSP430 Compiler > Advanced Options > Language Options and make sure the checkbox for “Enable support for GCC extensions (--gcc)” is checked.
7. In IAR,
 - (a) Create a new MSP430 project in IAR,
 - (b) Select the MSP430G2553 device,
 - (c) Copy the files in the project folder downloaded from TI.com to the new project directory.

5.3 MSP430 Pin-Out

The DRV2603EVM-CT contains a MSP430G2553 low-cost microcontroller which controls the board and contains sample haptic effects. The pin-out for the microcontroller can be found in [Table 4](#).

Table 4. MSP430 Pin-Out

#	Label	Description
1	P1.1	Green LED
2	P1.2	Yellow LED
3	P1.3	Blue LED
4	P1.4	VREF+
5	P1.5	Audio-to-Haptics
6	P3.1	Enable
7	P3.0	Actuator Mode Selection
8	NC	
9	P2.0	Button 1
10	P2.1	Button 2
11	P2.2	Button 3
12	P3.2	PWM
13	P3.3	WLED 0
14	P3.4	WLED 1
15	P2.3	Button 4
16	P2.4	"+" Button
17	P2.5	"-" Button
18	P3.5	WLED 2
19	P3.6	WLED 3
20	P3.7	WLED 4
21	P1.6/SCL	I ² C Clock
22	P1.7/SDA	I ² C Data
23	SBWTDIO	Spy-Bi-Wire Data
24	SBWTCK	Spy-Bi-Wire Clock
25	P2.7	
26	P2.6	LRA/ERM Load Switch
27	AVSS	Analog Ground
28	DVSS	Digital Ground
29	AVCC	Analog Supply
30	DVCC	Digital Supply
31	P1.0	Red LED
32	NC	

6 Schematic

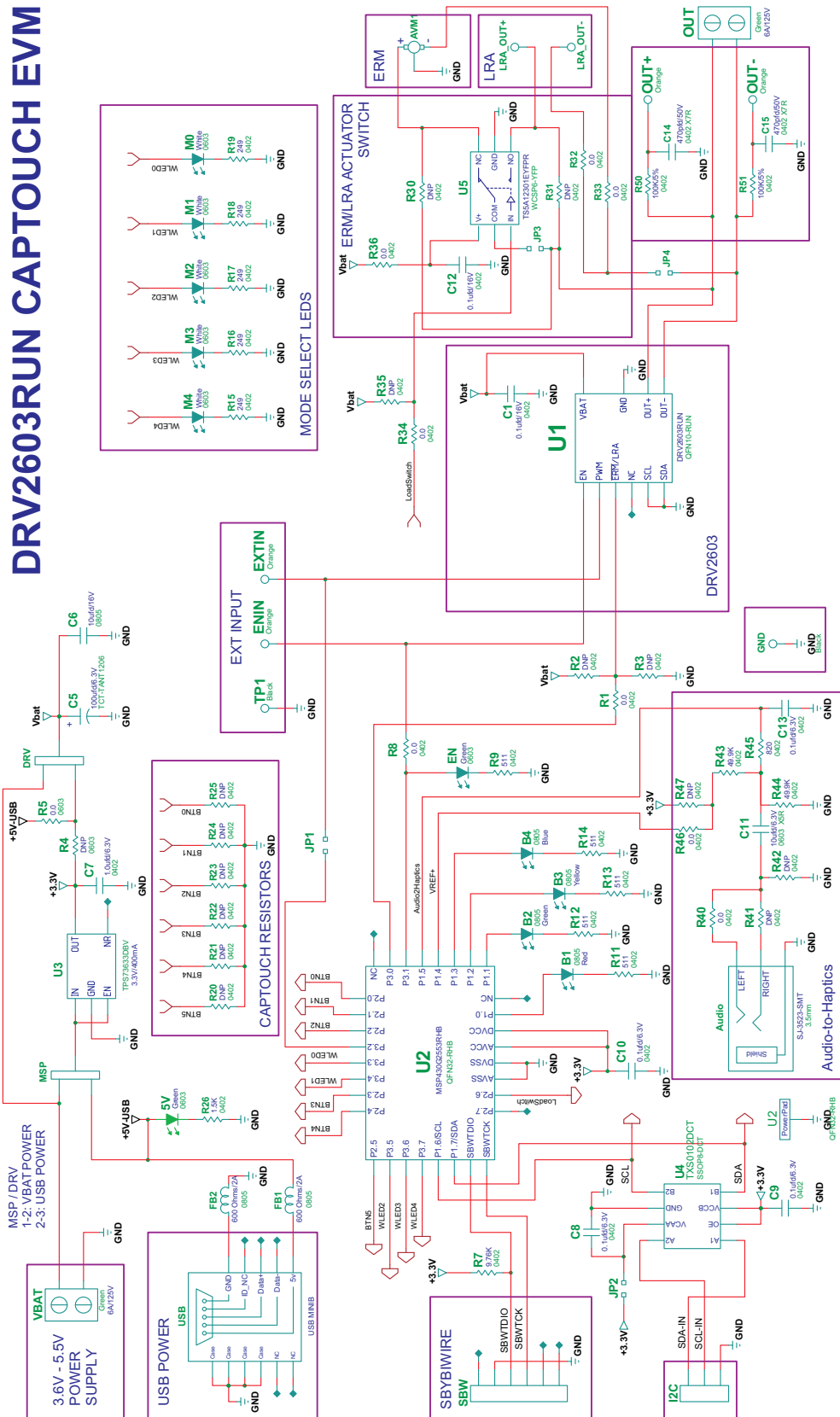

7 Layout

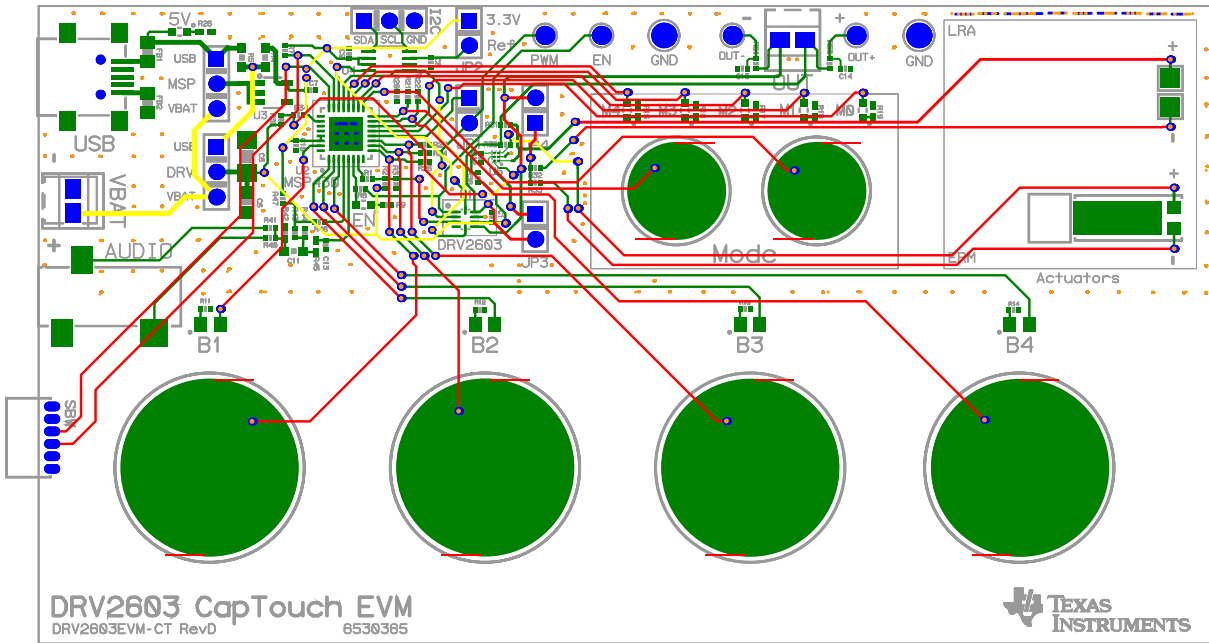

Figure 17. X-Ray Top View

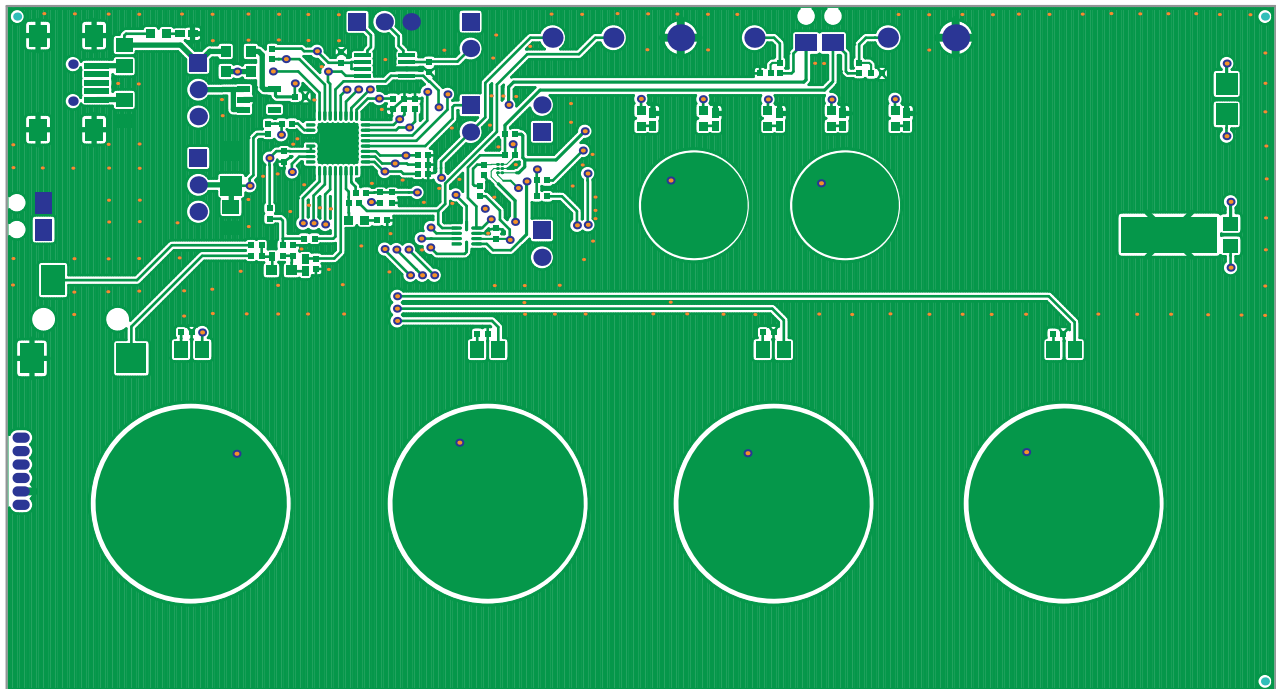

Figure 18. Top Copper

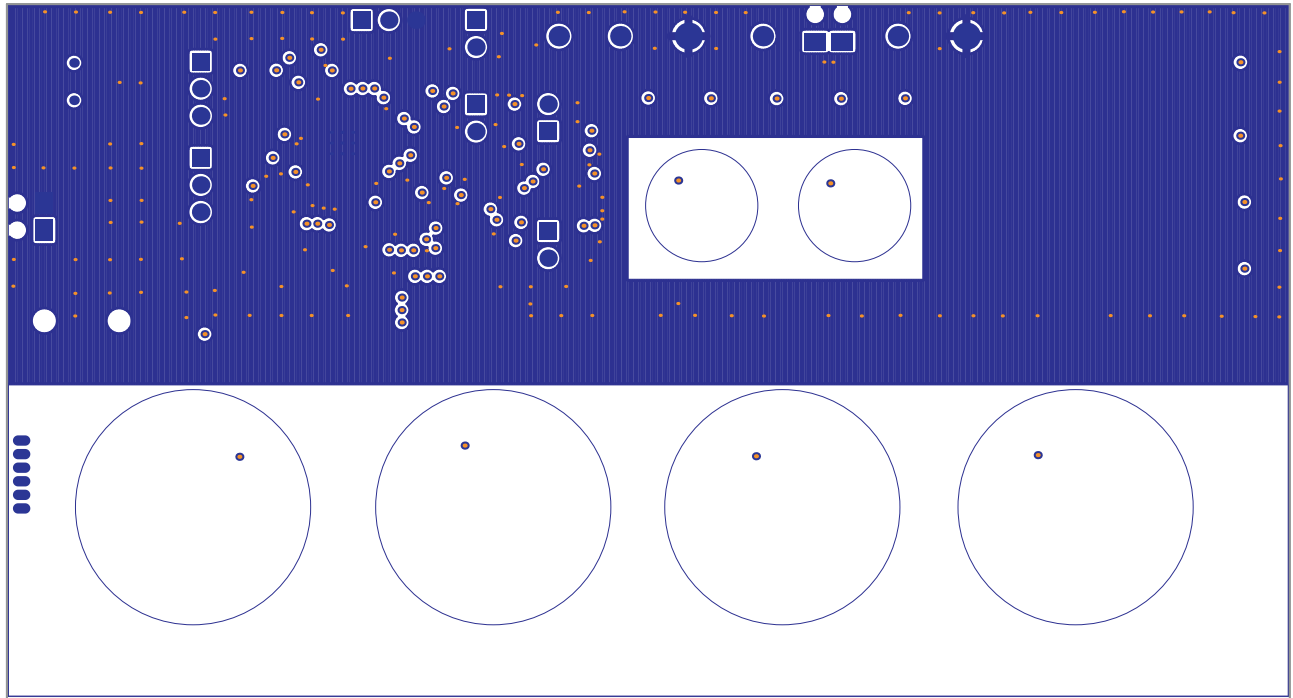

Figure 19. Layer 2 Copper

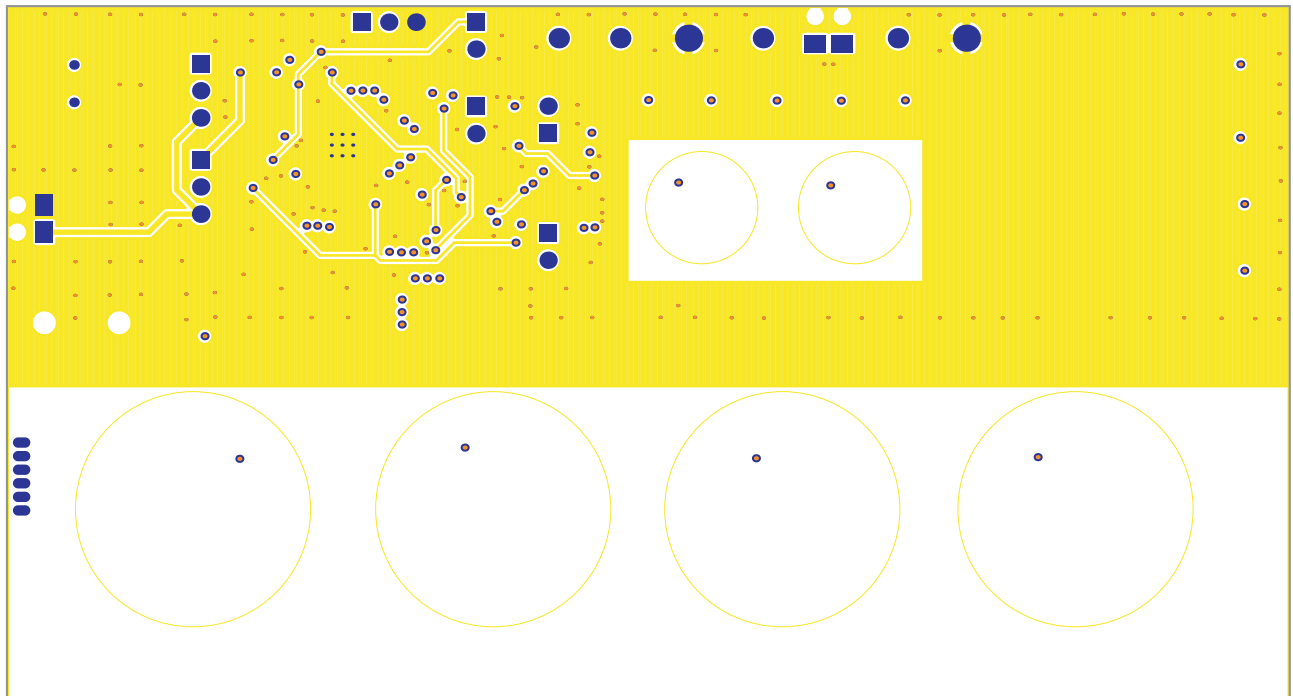

Figure 20. Layer 3 Copper

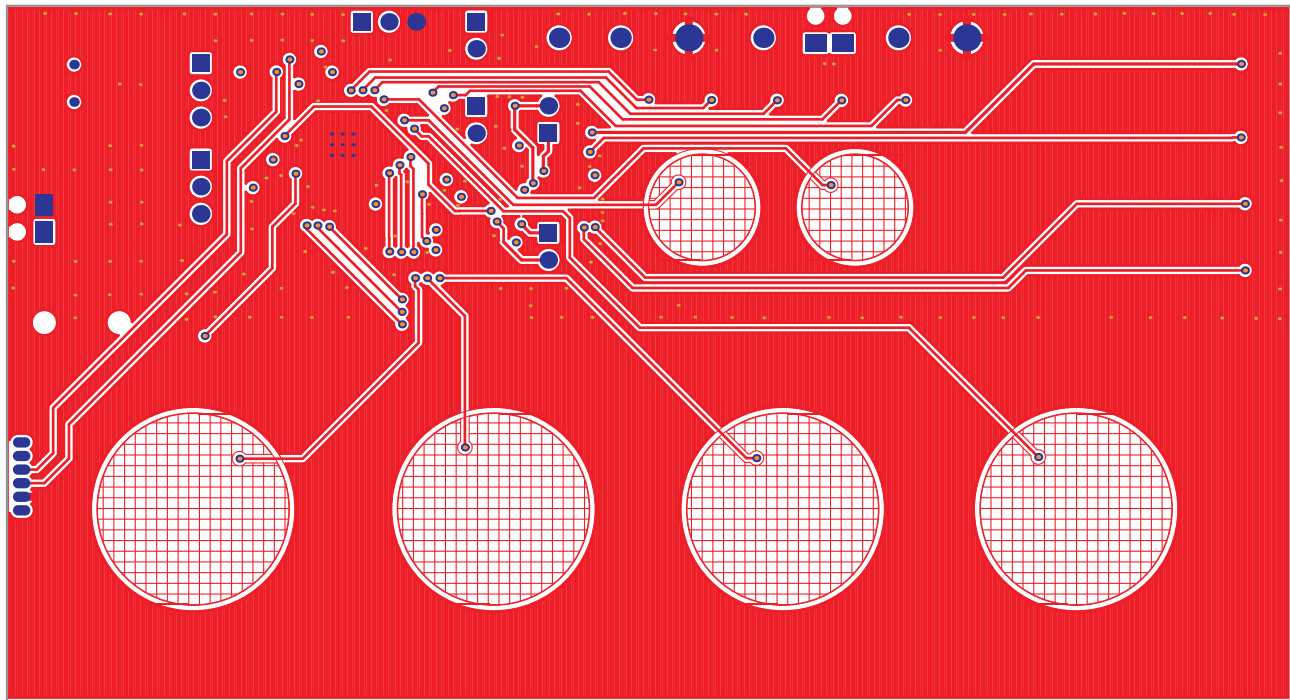

Figure 21. Bottom Copper

8 Bill of Materials

ITEM	MANU PARTNUM	QTY	REF DESIGNATORS	VENDOR PARTNUM	DESCRIPTION	VENDOR	MANUFACTURER
SEMICONDUCTORS							
1	DRV2603RUN	1	U1	DRV2603RUN	NO DATA YET QFN10-RUN ROHS	TEXAS INSTRUMENTS	TEXAS INSTRUMENTS
2	TXS0102DCTR	1	U4	296-21978-1	2-BIT BIDIR LEVEL TRANSLATOR SSOP8-DCT ROHS	DIGI-KEY	TEXAS INSTRUMENTS
3	MSP430G2553IRHB32T	1	U2	595-P430G2553IRHB32T	MIXED SIGNAL MICRO 16KB FLASH 512B RAM QFN32-RHB ROHS	MOUSER	TEXAS INSTRUMENTS
4	TPS73633MDBVREP	1	U3	296-21283-1	VOLT REG 3.3V 400MA LDO CAP FREE NMOS SOT23-DBV5 ROHS	DIGI-KEY	TEXAS INSTRUMENTS
5	TS5A12301EYFPR	1	U5	296-23757-1-ND	IEC LEVEL 4 ESD-PROTECTED 0.75-OHM ANALOG SWITCH WCSP6-YFP ROHS	DIGI-KEY	TEXAS INSTRUMENTS
6	LTST-C190KGKT	2	5V,EN	160-1435-1-ND	LED, GREEN, 2.0V, SMD0603, ROHS	DIGI-KEY	LITE-ON INC.
7	LNJ037X8ARA	5	M0,M1,M2,M3,M4	LNJ037X8ARACT-ND	LED, WHITE 2.9V SMD0805 ROHS	DIGI-KEY	PANASONIC
8	SML-LXT0805SRW-TR	1	B1	67-1555-1	LED, RED 2.0V SMD0805 ROHS	DIGI-KEY	LUMEX OPTO
9	SML-LXT0805GW-TR	1	B2	67-1553-1	LED, GREEN 2.0V SMD0805 ROHS	DIGI-KEY	LUMEX OPTO
10	SML-LXT0805YW-TR	1	B3	67-1554-1	LED, YELLOW 2.0V SMD0805 ROHS	DIGI-KEY	LUMEX OPTO
11	LTST-C171TBKT	1	B4	160-1645-1-ND	LED, BLUE 3.3V SMD0805 ROHS	DIGI-KEY	LITE-ON INC.
CAPACITORS							
12	GRM155R71C104KA88D	2	C1,C12	490-3261-1-ND	CAP SMD0402 CERM 0.1UFD 16V X7R 10% ROHS	DIGI-KEY	MURATA
13	C1005X5R0J104K	4	C8,C9,C10,C13	445-1266-1	CAP SMD0402 CERM 0.1UFD 6.3V 10% X5R ROHS	DIGI-KEY	TDK CORP
14	0805YD106KAT2A	1	C6	478-5165-1	CAP SMD0805 CERM 10UFD 16V X5R 10% ROHS	DIGI-KEY	AVX
15	GRM155R60J105KE19D	1	C7	490-1320-1	CAP SMD0402 CERM 1.0UFD 6.3V X5R 10% ROHS	DIGI-KEY	MURATA
16	GRM188R60J106ME47D	1	C11	490-3896-1-ND	CAP SMD0603 CERM 10UFD 6.3V 20% X5R ROHS	DIGI-KEY	MURATA
17	C0402C471K5RACTU	2	C14,C15	399-1025-1	CAP SMD0402 CERM 470PFD 50V 10% X7R ROHS	DIGI-KEY	KEMET
18	TCTAL0J107M8R	1	C5	511-1498-1-ND	CAP TANT1206 100UFD 6.3V 20% TCT SERIES ROHS	DIGI-KEY	ROHM

ITEM	MANU PARTNUM	QTY	REF DESIGNATORS	VENDOR PARTNUM	DESCRIPTION	VENDOR	MANUFACTURER
RESISTORS							
19	ERJ-2GEJ821	1	R45		RESISTOR,SMT,0402,THICK FILM,5%,1/16W,820		
20	ERJ-2RKF9761X	1	R7	P9.76KLCT-ND	RESISTOR SMD0402 THICK FILM 9.76K OHMS 1/10W 1% ROHS	DIGI-KEY	PANASONIC
21	RMCF0402ZT0R00	6	R1,R8,R32,R33,R34,R36	RMCF0402ZT0R00CT	ZERO OHM JUMPER SMT 0402 0 OHM 1/16W,5% ROHS	DIGI-KEY	STACKPOLE ELECTRONICS
22	RC0402FR-07511RL	5	R9,R11,R12,R13,R14	311-511LRCT-ND	RESISTOR SMD0402 THICK FILM 511 OHMS 1% 1/16W ROHS	DIGI-KEY	YAGEO
23	ERJ-2GEJ152	1	R26		RESISTOR,SMT,0402,THICK FILM,5%,1/16W,1.5K		Panasonic
24	RMCF0603ZT0R00	1	R5	RMCF0603ZT0R00CT-ND	RESISTOR SMD0603 ZERO OHMS 1/10W ROHS	DIGI-KEY	STACKPOLE ELECTRONICS
25	ERJ-2RKF2490X	5	R15,R16,R17,R18,R19	P249LTR-ND	RESISTOR,SMT,0402,249 OHM,1%,1/16W	DIGI-KEY	Panasonic
26	ERJ-2RKF4992X	2	R43,R44	P49.9KLCT	RESISTOR SMD0402 THICK FILM 49.9K OHMS 1/16W 1% ROHS	DIGI-KEY	PANASONIC
27	CRCW04020000Z0ED	2	R40,R46	541-0.0JCT	ZERO OHM JUMPER SMT 0402 0 OHM 1/16W,5% ROHS	DIGI-KEY	VISHAY
28	ERJ-2GEJ104	2	R50,R51	P100KJCT	RESISTOR SMD0402 THICK FILM 100K OHMS 1/16W 5% ROHS	DIGI-KEY	PANASONIC
FERRITE BEADS							
29	MPZ2012S601A	2	FB1,FB2	445-2206-1	FERRITE BEAD SMD0805 600 Ohms 2A ROHS	DIGI-KEY	TDK
HEADERS, JACKS, AND SHUNTS							
30	LPPB061NGCN-RC	1	SBW	S9010E-06	HEADER THRU FEMALE 1X6-RA 50LS GOLD ROHS	DIGI-KEY	SULLINS
31	PBC03SAAN	3	DRV,I2C,MSP	S1011E-03-ND	HEADER THRU MALE 3 PIN 100LS GOLD ROHS	DIGI-KEY	SULLINS
32	PBC02SAAN	1	JP2	S1011E-02	HEADER THRU MALE 2 PIN 100LS GOLD ROHS	DIGI-KEY	SULLINS
33	PBC02SAAN	3	JP1,JP3,JP4		HEADER THRU MALE 2 PIN 100LS GOLD ROHS	DIGI-KEY	SULLINS
34	UX60-MB-5ST	1	USB	H2959CT	JACK USB MINIB SMT-RA 5PIN ROHS	DIGI-KEY	HIROSE
35	SJ-3523-SMT	1	Audio	CP-3523SJCT-ND	JACK AUDIO-STEREO MINI(3.5MM ,3-COND SMT-RA ROHS	DIGI-KEY	CUI STACK
36	SPC02SYAN	6	MSP (2-3), DRV (2-3), JP1, JP2, JP3, JP4	S9001-ND	SHUNT BLACK AU FLASH 0.100LS CLOSED TOP ROHS	DIGI-KEY	SULLINS
37	1725656	2	OUT,VBAT	277-1273	TERMINAL BLOCK MPT COMBICON 2PIN 6A/125V GREEN 100LS ROHS	DIGI-KEY	PHOENIX CONTACT

ITEM	MANU PARTNUM	QTY	REF DESIGNATORS	VENDOR PARTNUM	DESCRIPTION	VENDOR	MANUFACTURER
TESTPOINTS AND SWITCHES							
38	5003	4	ENIN,OUT+,OUT-,EXTIN (Solder so that color ring is secured)	5003K	PC TESTPOINT, ORANGE, ROHS	DIGI-KEY	KEystone ELECTRONICS
39	5011	2	GND,TP1 (Solder so that color ring is secured)	5011K	PC TESTPOINT BLACK 063 HOLE ROHS	DIGI-KEY	KEystone ELECTRONICS
40	NRS-2574	1	AVM1	NRS-2574	ACUTATOR VIBRATION MOTOR 1,3V 9000 RPM ROHS	SANYO	SANYO
41	ELV1036A	1	-	-	ACTUATOR - LINEAR VIBRATOR, 2VRMS	AAC	AAC
42	-	1	-	-	Metal Block (Custom Block, Heavy Metal, See metal block spec)	Heavy Metal	Heavy Metal
43	3-5-468MP	1	-	3M9724-ND	TAPE TRANSFER ADHESIVE 3" X 5YD	DIGI-KEY	3M
44	2-5-4466W	1	-	3M9962-ND	TAPE POLY FOAM 2" x 5YD	DIGI-KEY	3M
COMPONENTS NOT ASSEMBLED							
45	R0402_DNP	11	R2,R3,R20,R21,R22,R23,R24,R25,R30,R31,R35		R0402_DNP		
46	TestPoint_SMD-Square_2.0mm	2	LRA_OUT+,LRA_OUT-		TESTPOINT SMD SQUARE 2.0mm		
47	R0603_DNP	1	R4	RMCF0603ZT0R00CT-ND	R0603_DNP	DIGI-KEY	STACKPOLE ELECTRONICS
48	R0402_DNP	2	R41,R47	P4.99KLCT-ND	R0402_DNP	DIGI-KEY	PANASONIC
49	R0402_DNP	1	R42	541-0.0JCT	R0402_DNP	DIGI-KEY	VISHAY

EVALUATION BOARD/KIT/MODULE (EVM) ADDITIONAL TERMS

Texas Instruments (TI) provides the enclosed Evaluation Board/Kit/Module (EVM) under the following conditions:

The user assumes all responsibility and liability for proper and safe handling of the goods. Further, the user indemnifies TI from all claims arising from the handling or use of the goods.

Should this evaluation board/kit not meet the specifications indicated in the User's Guide, the board/kit may be returned within 30 days from the date of delivery for a full refund. THE FOREGOING LIMITED WARRANTY IS THE EXCLUSIVE WARRANTY MADE BY SELLER TO BUYER AND IS IN LIEU OF ALL OTHER WARRANTIES, EXPRESSED, IMPLIED, OR STATUTORY, INCLUDING ANY WARRANTY OF MERCHANTABILITY OR FITNESS FOR ANY PARTICULAR PURPOSE. EXCEPT TO THE EXTENT OF THE INDEMNITY SET FORTH ABOVE, NEITHER PARTY SHALL BE LIABLE TO THE OTHER FOR ANY INDIRECT, SPECIAL, INCIDENTAL, OR CONSEQUENTIAL DAMAGES.

Please read the User's Guide and, specifically, the Warnings and Restrictions notice in the User's Guide prior to handling the product. This notice contains important safety information about temperatures and voltages. For additional information on TI's environmental and/or safety programs, please visit www.ti.com/esh or contact TI.

No license is granted under any patent right or other intellectual property right of TI covering or relating to any machine, process, or combination in which such TI products or services might be or are used. TI currently deals with a variety of customers for products, and therefore our arrangement with the user is not exclusive. TI assumes no liability for applications assistance, customer product design, software performance, or infringement of patents or services described herein.

REGULATORY COMPLIANCE INFORMATION

As noted in the EVM User's Guide and/or EVM itself, this EVM and/or accompanying hardware may or may not be subject to the Federal Communications Commission (FCC) and Industry Canada (IC) rules.

For EVMs **not** subject to the above rules, this evaluation board/kit/module is intended for use for ENGINEERING DEVELOPMENT, DEMONSTRATION OR EVALUATION PURPOSES ONLY and is not considered by TI to be a finished end product fit for general consumer use. It generates, uses, and can radiate radio frequency energy and has not been tested for compliance with the limits of computing devices pursuant to part 15 of FCC or ICES-003 rules, which are designed to provide reasonable protection against radio frequency interference. Operation of the equipment may cause interference with radio communications, in which case the user at his own expense will be required to take whatever measures may be required to correct this interference.

General Statement for EVMs including a radio

User Power/Frequency Use Obligations: This radio is intended for development/professional use only in legally allocated frequency and power limits. Any use of radio frequencies and/or power availability of this EVM and its development application(s) must comply with local laws governing radio spectrum allocation and power limits for this evaluation module. It is the user's sole responsibility to only operate this radio in legally acceptable frequency space and within legally mandated power limitations. Any exceptions to this are strictly prohibited and unauthorized by Texas Instruments unless user has obtained appropriate experimental/development licenses from local regulatory authorities, which is responsibility of user including its acceptable authorization.

For EVMs annotated as FCC – FEDERAL COMMUNICATIONS COMMISSION Part 15 Compliant

Caution

This device complies with part 15 of the FCC Rules. Operation is subject to the following two conditions: (1) This device may not cause harmful interference, and (2) this device must accept any interference received, including interference that may cause undesired operation.

Changes or modifications not expressly approved by the party responsible for compliance could void the user's authority to operate the equipment.

FCC Interference Statement for Class A EVM devices

This equipment has been tested and found to comply with the limits for a Class A digital device, pursuant to part 15 of the FCC Rules. These limits are designed to provide reasonable protection against harmful interference when the equipment is operated in a commercial environment. This equipment generates, uses, and can radiate radio frequency energy and, if not installed and used in accordance with the instruction manual, may cause harmful interference to radio communications. Operation of this equipment in a residential area is likely to cause harmful interference in which case the user will be required to correct the interference at his own expense.

FCC Interference Statement for Class B EVM devices

This equipment has been tested and found to comply with the limits for a Class B digital device, pursuant to part 15 of the FCC Rules. These limits are designed to provide reasonable protection against harmful interference in a residential installation. This equipment generates, uses and can radiate radio frequency energy and, if not installed and used in accordance with the instructions, may cause harmful interference to radio communications. However, there is no guarantee that interference will not occur in a particular installation. If this equipment does cause harmful interference to radio or television reception, which can be determined by turning the equipment off and on, the user is encouraged to try to correct the interference by one or more of the following measures:

- Reorient or relocate the receiving antenna.
- Increase the separation between the equipment and receiver.
- Connect the equipment into an outlet on a circuit different from that to which the receiver is connected.
- Consult the dealer or an experienced radio/TV technician for help.

For EVMs annotated as IC – INDUSTRY CANADA Compliant

This Class A or B digital apparatus complies with Canadian ICES-003.

Changes or modifications not expressly approved by the party responsible for compliance could void the user's authority to operate the equipment.

Concerning EVMs including radio transmitters

This device complies with Industry Canada licence-exempt RSS standard(s). Operation is subject to the following two conditions: (1) this device may not cause interference, and (2) this device must accept any interference, including interference that may cause undesired operation of the device.

Concerning EVMs including detachable antennas

Under Industry Canada regulations, this radio transmitter may only operate using an antenna of a type and maximum (or lesser) gain approved for the transmitter by Industry Canada. To reduce potential radio interference to other users, the antenna type and its gain should be so chosen that the equivalent isotropically radiated power (e.i.r.p.) is not more than that necessary for successful communication.

This radio transmitter has been approved by Industry Canada to operate with the antenna types listed in the user guide with the maximum permissible gain and required antenna impedance for each antenna type indicated. Antenna types not included in this list, having a gain greater than the maximum gain indicated for that type, are strictly prohibited for use with this device.

Cet appareil numérique de la classe A ou B est conforme à la norme NMB-003 du Canada.

Les changements ou les modifications pas expressément approuvés par la partie responsable de la conformité ont pu vider l'autorité de l'utilisateur pour actionner l'équipement.

Concernant les EVMs avec appareils radio

Le présent appareil est conforme aux CNR d'Industrie Canada applicables aux appareils radio exempts de licence. L'exploitation est autorisée aux deux conditions suivantes : (1) l'appareil ne doit pas produire de brouillage, et (2) l'utilisateur de l'appareil doit accepter tout brouillage radioélectrique subi, même si le brouillage est susceptible d'en compromettre le fonctionnement.

Concernant les EVMs avec antennes détachables

Conformément à la réglementation d'Industrie Canada, le présent émetteur radio peut fonctionner avec une antenne d'un type et d'un gain maximal (ou inférieur) approuvé pour l'émetteur par Industrie Canada. Dans le but de réduire les risques de brouillage radioélectrique à l'intention des autres utilisateurs, il faut choisir le type d'antenne et son gain de sorte que la puissance isotrope rayonnée équivalente (p.i.r.e.) ne dépasse pas l'intensité nécessaire à l'établissement d'une communication satisfaisante.

Le présent émetteur radio a été approuvé par Industrie Canada pour fonctionner avec les types d'antenne énumérés dans le manuel d'usage et ayant un gain admissible maximal et l'impédance requise pour chaque type d'antenne. Les types d'antenne non inclus dans cette liste, ou dont le gain est supérieur au gain maximal indiqué, sont strictement interdits pour l'exploitation de l'émetteur.

【Important Notice for Users of this Product in Japan】

This development kit is NOT certified as Confirming to Technical Regulations of Radio Law of Japan

If you use this product in Japan, you are required by Radio Law of Japan to follow the instructions below with respect to this product:

1. Use this product in a shielded room or any other test facility as defined in the notification #173 issued by Ministry of Internal Affairs and Communications on March 28, 2006, based on Sub-section 1.1 of Article 6 of the Ministry's Rule for Enforcement of Radio Law of Japan,
2. Use this product only after you obtained the license of Test Radio Station as provided in Radio Law of Japan with respect to this product, or
3. Use of this product only after you obtained the Technical Regulations Conformity Certification as provided in Radio Law of Japan with respect to this product. Also, please do not transfer this product, unless you give the same notice above to the transferee. Please note that if you could not follow the instructions above, you will be subject to penalties of Radio Law of Japan.

Texas Instruments Japan Limited
(address) 24-1, Nishi-Shinjuku 6 chome, Shinjuku-ku, Tokyo, Japan

<http://www.tij.co.jp>

【ご使用にあたっての注】

本開発キットは技術基準適合証明を受けておりません。

本製品のご使用に際しては、電波法遵守のため、以下のいずれかの措置を取っていただく必要がありますのでご注意ください。

1. 電波法施行規則第6条第1項第1号に基づく平成18年3月28日総務省告示第173号で定められた電波暗室等の試験設備でご使用いただく。
2. 実験局の免許を取得後ご使用いただく。
3. 技術基準適合証明を取得後ご使用いただく。

なお、本製品は、上記の「ご使用にあたっての注意」を譲渡先、移転先に通知しない限り、譲渡、移転できないものとします。

上記を遵守頂けない場合は、電波法の罰則が適用される可能性があることをご留意ください。

日本テキサス・インスツルメンツ株式会社
東京都新宿区西新宿6丁目24番1号
西新宿三井ビル

<http://www.tij.co.jp>

EVALUATION BOARD/KIT/MODULE (EVM) WARNINGS, RESTRICTIONS AND DISCLAIMERS

For Feasibility Evaluation Only, in Laboratory/Development Environments. Unless otherwise indicated, this EVM is not a finished electrical equipment and not intended for consumer use. It is intended solely for use for preliminary feasibility evaluation in laboratory/development environments by technically qualified electronics experts who are familiar with the dangers and application risks associated with handling electrical mechanical components, systems and subsystems. It should not be used as all or part of a finished end product.

Your Sole Responsibility and Risk. You acknowledge, represent and agree that:

1. You have unique knowledge concerning Federal, State and local regulatory requirements (including but not limited to Food and Drug Administration regulations, if applicable) which relate to your products and which relate to your use (and/or that of your employees, affiliates, contractors or designees) of the EVM for evaluation, testing and other purposes.
2. You have full and exclusive responsibility to assure the safety and compliance of your products with all such laws and other applicable regulatory requirements, and also to assure the safety of any activities to be conducted by you and/or your employees, affiliates, contractors or designees, using the EVM. Further, you are responsible to assure that any interfaces (electronic and/or mechanical) between the EVM and any human body are designed with suitable isolation and means to safely limit accessible leakage currents to minimize the risk of electrical shock hazard.
3. You will employ reasonable safeguards to ensure that your use of the EVM will not result in any property damage, injury or death, even if the EVM should fail to perform as described or expected.
4. You will take care of proper disposal and recycling of the EVM's electronic components and packing materials.

Certain Instructions. It is important to operate this EVM within TI's recommended specifications and environmental considerations per the user guidelines. Exceeding the specified EVM ratings (including but not limited to input and output voltage, current, power, and environmental ranges) may cause property damage, personal injury or death. If there are questions concerning these ratings please contact a TI field representative prior to connecting interface electronics including input power and intended loads. Any loads applied outside of the specified output range may result in unintended and/or inaccurate operation and/or possible permanent damage to the EVM and/or interface electronics. Please consult the EVM User's Guide prior to connecting any load to the EVM output. If there is uncertainty as to the load specification, please contact a TI field representative. During normal operation, some circuit components may have case temperatures greater than 60°C as long as the input and output are maintained at a normal ambient operating temperature. These components include but are not limited to linear regulators, switching transistors, pass transistors, and current sense resistors which can be identified using the EVM schematic located in the EVM User's Guide. When placing measurement probes near these devices during normal operation, please be aware that these devices may be very warm to the touch. As with all electronic evaluation tools, only qualified personnel knowledgeable in electronic measurement and diagnostics normally found in development environments should use these EVMs.

Agreement to Defend, Indemnify and Hold Harmless. You agree to defend, indemnify and hold TI, its licensors and their representatives harmless from and against any and all claims, damages, losses, expenses, costs and liabilities (collectively, "Claims") arising out of or in connection with any use of the EVM that is not in accordance with the terms of the agreement. This obligation shall apply whether Claims arise under law of tort or contract or any other legal theory, and even if the EVM fails to perform as described or expected.

Safety-Critical or Life-Critical Applications. If you intend to evaluate the components for possible use in safety critical applications (such as life support) where a failure of the TI product would reasonably be expected to cause severe personal injury or death, such as devices which are classified as FDA Class III or similar classification, then you must specifically notify TI of such intent and enter into a separate Assurance and Indemnity Agreement.

Mailing Address: Texas Instruments, Post Office Box 655303, Dallas, Texas 75265
Copyright © 2012, Texas Instruments Incorporated

IMPORTANT NOTICE

Texas Instruments Incorporated and its subsidiaries (TI) reserve the right to make corrections, modifications, enhancements, improvements, and other changes to its products and services at any time and to discontinue any product or service without notice. Customers should obtain the latest relevant information before placing orders and should verify that such information is current and complete. All products are sold subject to TI's terms and conditions of sale supplied at the time of order acknowledgment.

TI warrants performance of its hardware products to the specifications applicable at the time of sale in accordance with TI's standard warranty. Testing and other quality control techniques are used to the extent TI deems necessary to support this warranty. Except where mandated by government requirements, testing of all parameters of each product is not necessarily performed.

TI assumes no liability for applications assistance or customer product design. Customers are responsible for their products and applications using TI components. To minimize the risks associated with customer products and applications, customers should provide adequate design and operating safeguards.

TI does not warrant or represent that any license, either express or implied, is granted under any TI patent right, copyright, mask work right, or other TI intellectual property right relating to any combination, machine, or process in which TI products or services are used. Information published by TI regarding third-party products or services does not constitute a license from TI to use such products or services or a warranty or endorsement thereof. Use of such information may require a license from a third party under the patents or other intellectual property of the third party, or a license from TI under the patents or other intellectual property of TI.

Reproduction of TI information in TI data books or data sheets is permissible only if reproduction is without alteration and is accompanied by all associated warranties, conditions, limitations, and notices. Reproduction of this information with alteration is an unfair and deceptive business practice. TI is not responsible or liable for such altered documentation. Information of third parties may be subject to additional restrictions.

Resale of TI products or services with statements different from or beyond the parameters stated by TI for that product or service voids all express and any implied warranties for the associated TI product or service and is an unfair and deceptive business practice. TI is not responsible or liable for any such statements.

TI products are not authorized for use in safety-critical applications (such as life support) where a failure of the TI product would reasonably be expected to cause severe personal injury or death, unless officers of the parties have executed an agreement specifically governing such use. Buyers represent that they have all necessary expertise in the safety and regulatory ramifications of their applications, and acknowledge and agree that they are solely responsible for all legal, regulatory and safety-related requirements concerning their products and any use of TI products in such safety-critical applications, notwithstanding any applications-related information or support that may be provided by TI. Further, Buyers must fully indemnify TI and its representatives against any damages arising out of the use of TI products in such safety-critical applications.

TI products are neither designed nor intended for use in military/aerospace applications or environments unless the TI products are specifically designated by TI as military-grade or "enhanced plastic." Only products designated by TI as military-grade meet military specifications. Buyers acknowledge and agree that any such use of TI products which TI has not designated as military-grade is solely at the Buyer's risk, and that they are solely responsible for compliance with all legal and regulatory requirements in connection with such use.

TI products are neither designed nor intended for use in automotive applications or environments unless the specific TI products are designated by TI as compliant with ISO/TS 16949 requirements. Buyers acknowledge and agree that, if they use any non-designated products in automotive applications, TI will not be responsible for any failure to meet such requirements.

Following are URLs where you can obtain information on other Texas Instruments products and application solutions:

Products

Audio	www.ti.com/audio
Amplifiers	amplifier.ti.com
Data Converters	dataconverter.ti.com
DLP® Products	www.dlp.com
DSP	dsp.ti.com
Clocks and Timers	www.ti.com/clocks
Interface	interface.ti.com
Logic	logic.ti.com
Power Mgmt	power.ti.com
Microcontrollers	microcontroller.ti.com
RFID	www.ti-rfid.com
OMAP Mobile Processors	www.ti.com/omap
Wireless Connectivity	www.ti.com/wirelessconnectivity

Applications

Automotive and Transportation	www.ti.com/automotive
Communications and Telecom	www.ti.com/communications
Computers and Peripherals	www.ti.com/computers
Consumer Electronics	www.ti.com/consumer-apps
Energy and Lighting	www.ti.com/energy
Industrial	www.ti.com/industrial
Medical	www.ti.com/medical
Security	www.ti.com/security
Space, Avionics and Defense	www.ti.com/space-avionics-defense
Video and Imaging	www.ti.com/video

TI E2E Community Home Page

e2e.ti.com

Mailing Address: Texas Instruments, Post Office Box 655303, Dallas, Texas 75265
Copyright © 2012, Texas Instruments Incorporated