

AME8821

■ General Description

The AME8821 family of positive, linear regulators feature low quiescent current (17 μ A typ.) with low dropout voltage, making them ideal for battery applications. The space-saving SOT-25/TSOT-25 packages are attractive for "Pocket" and "Hand Held" applications.

These rugged devices have both Thermal Shutdown, and Current Limitation to prevent device failure under the "Worst" operating conditions. In application requires a low noise regulated supply. The AME8821 family uses the SR pin to program the output voltage's slew rate to control the in-rush current. This is specifically used in the USB application where large load capacitance is present at start-up.

The AME8821 also features a logic-enabled sleep mode to shutdown the regulator, reducing quiescent current to 1 μ A typical at $T_A = 25^\circ\text{C}$.

The AME8821 is stable with an output capacitance of 4.7 μ F or larger.

■ Features

- Guaranteed 250mA Output
- 17 μ A Quiescent Current
- Over-Temperature Shutdown
- Over-Current Limitation
- Noise Reduction SR Capacitor
- Power-Saving Shutdown Mode
- Space-Saving SOT-25/TSOT-25 Packages
- Factory Pre-set Output Voltages
- Enable pin option
 - ENB active low enable
 - EN active high enable
- All AME's Lead Free Products Meet RoHS Standards

■ Applications

- Instrumentation
- Portable Electronics
- Wireless Devices
- Cordless Phones
- PC Peripherals
- Battery Powered Widgets

■ Function Block Diagram

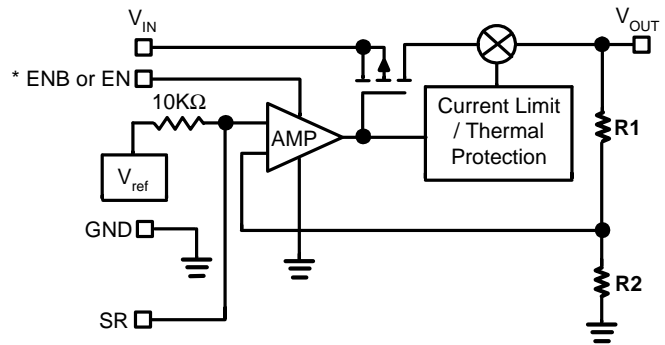

* AME8821A: ENB, AME8821B: EN

■ Typical Application

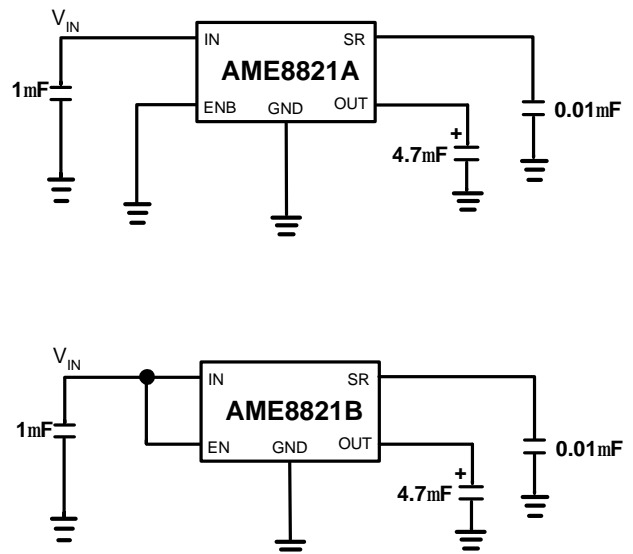

AME8821

■ Pin Configuration

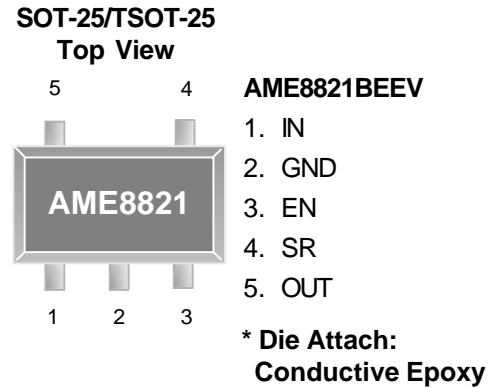
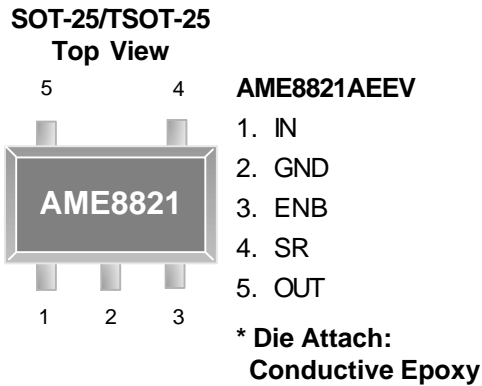

■ Pin Description

Pin Number	Pin Name	Pin Description
1	IN	Input voltage pin. It should be decoupled with 1 μ F or greater capacitor.
2	GND	Ground connection pin.
3	EN	Enable pin. When pulled low, the PMOS pass transistor turns off, current consuming less than 1 μ A.
	ENB	Enable bar pin. When pulled high, the PMOS pass transistor turns off, current consuming less than 1 μ A.
4	SR	The SR(Slew Rate) terminal is used to control the V_{OUT} in-rush current.
5	OUT	LDO voltage regulator output pin. It should be decoupled with a 4.7 μ F or greater value low ESR ceramic capacitor.

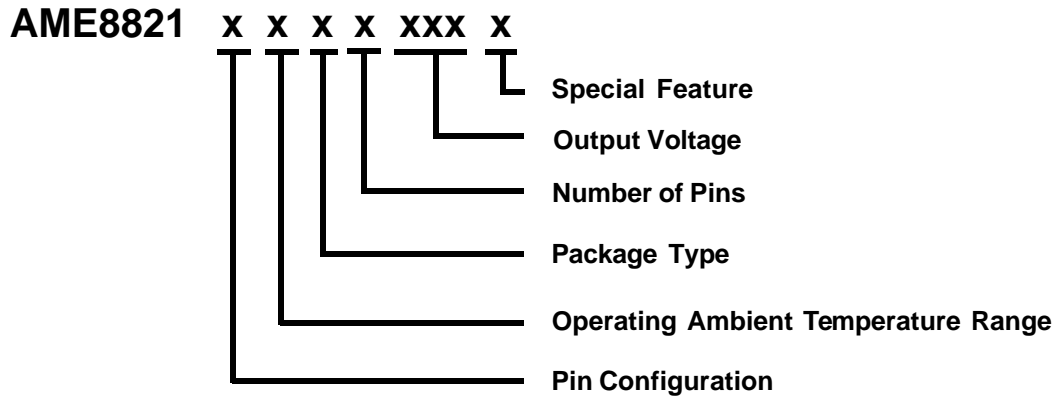
AME8821
■ Ordering Information

Pin Configuration	Operating Ambient Temperature Range	Package Type	Number of Pins	Output Voltage	Special Feature
A: 1. IN <small>(SOT-25)</small> 2. GND <small>(TSOT-25)</small> 3. ENB 4. SR 5. OUT B: 1. IN <small>(SOT-25)</small> 2. GND <small>(TSOT-25)</small> 3. EN 4. SR 5. OUT	E: -40°C to +85°C	E: SOT-2X	V: 5	180: V=1.8V 250: V=2.5V 285: V=2.85V 300: V=3.0V 330: V=3.3V	Y: Lead free & Low profile Z: Lead free

■ Ordering Information

Part Number	Marking*	Output Voltage	Package	Operating Ambient Temperature Range
AME8821AEEV180Z	BHXww	1.8V	SOT-25	- 40°C to +85°C
AME8821AEEV180Y	BHXww	1.8V	TSOT-25	- 40°C to +85°C
AME8821AEEV250Z	BHYww	2.5V	SOT-25	- 40°C to +85°C
AME8821AEEV250Y	BHYww	2.5V	TSOT-25	- 40°C to +85°C
AME8821AEEV285Z	BHZww	2.85V	SOT-25	- 40°C to +85°C
AME8821AEEV285Y	BHZww	2.85V	TSOT-25	- 40°C to +85°C
AME8821AEEV300Z	BIAww	3.0V	SOT-25	- 40°C to +85°C
AME8821AEEV300Y	BIAww	3.0V	TSOT-25	- 40°C to +85°C
AME8821AEEV330Z	BIBww	3.3V	SOT-25	- 40°C to +85°C
AME8821AEEV330Y	BIBww	3.3V	TSOT-25	- 40°C to +85°C
AME8821BEEV180Z	BICww	1.8V	SOT-25	- 40°C to +85°C
AME8821BEEV180Y	BICww	1.8V	TSOT-25	- 40°C to +85°C
AME8821BEEV250Z	BIDww	2.5V	SOT-25	- 40°C to +85°C
AME8821BEEV250Y	BIDww	2.5V	TSOT-25	- 40°C to +85°C
AME8821BEEV285Z	BIEww	2.85V	SOT-25	- 40°C to +85°C
AME8821BEEV285Y	BIEww	2.85V	TSOT-25	- 40°C to +85°C
AME8821BEEV300Z	BIFww	3.0V	SOT-25	- 40°C to +85°C
AME8821BEEV300Y	BIFww	3.0V	TSOT-25	- 40°C to +85°C
AME8821BEEV330Z	BIGww	3.3V	SOT-25	- 40°C to +85°C
AME8821BEEV330Y	BIGww	3.3V	TSOT-25	- 40°C to +85°C

Note: ww represents the date code and pls refer to the Date Code Rule before Package Dimension.

* A line on top of the first character represents lead free plating such as $\overline{\text{B}}\text{HXww}$.

Please consult AME sales office or authorized Rep./Distributor for output voltage and package type availability.



AME8821

■ **Absolute Maximum Ratings**

Parameter	Maximum	Unit
Input Voltage	6	V
Output Current	$P_D / (V_{IN} - V_{OUT})$	mA
Output Voltage	GND-0.3 to $V_{IN}+0.3$	V
ESD Classification	C*	

Caution: Stress above the listed absolute maximum rating may cause permanent damage to the device

* HBM C: 4000V+

■ **Recommended Operating Conditions**

Parameter	Symbol	Rating	Unit
Ambient Temperature Range	T_A	- 40 to +85	°C
Junction Temperature Range	T_J	- 40 to +125	
Storage Temperature Range	T_{STG}	-65 to +150	

■ **Thermal Information**

Parameter	Package	Die Attach	Symbol	Maximum	Unit
Thermal Resistance* (Junction to Case)	SOT-25 TSOT-25	Conductive Epoxy	θ_{JC}	81	°C / W
Thermal Resistance (Junction to Ambient)			θ_{JA}	260	
Internal Power Dissipation			P_D	400	mW
Solder Iron (10 Sec)**				350	°C

* Measure θ_{JC} on center of molding compound if IC has no tab.

** MIL-STD-202G 210F

■ Electrical Specifications

Over operating temperature range ($T_J = -40^\circ\text{C}$ to 125°C), $V_{IN} = V_{OUT(nom)} + 1\text{V}$, or $V_{IN} = V_{IN(min)}$ whichever is greater, $I_{OUT} = 1\text{mA}$, $V_{EN} = V_{IN}$ ($V_{ENB} = 0$), and $C_{OUT} = 4.7\mu\text{F}$, $C_{IN} = 1\mu\text{F}$ unless otherwise noted. Typical values are at $T_A = 25^\circ\text{C}$.

Parameter	Symbol	Test Condition	Min	Typ	Max	Units	
Input Voltage	V_{IN}		Note1		5.5	V	
Output Voltage Accuracy	$V_{OUT(nom)}$	$T_A = 25^\circ\text{C}$ $T_J = -40^\circ\text{C}$ to $+125^\circ\text{C}$	-1.5		1.5	%	
			-3		3		
Output Voltage Line Regulation $\frac{DV_{OUT}}{V_{OUT}} \times 100\%$ $D V_{IN}$	REG _{LINE}	$V_{OUT} = 1.8\text{V}$, $2.5\text{V} < V_{IN} < 5.5\text{V}$	$T_A = 25^\circ\text{C}$	-0.30	0.2	0.3	%/ V
			$T_J = -40^\circ\text{C}$ to $+125^\circ\text{C}$	-0.40		0.4	
		$V_{OUT} = 2.5\text{V}$, $3\text{V} < V_{IN} < 5.5\text{V}$	$T_A = 25^\circ\text{C}$	-0.25	0.15	0.25	
			$T_J = -40^\circ\text{C}$ to $+125^\circ\text{C}$	-0.35		0.35	
		$V_{OUT} = 2.85\text{V}$, $3.3\text{V} < V_{IN} < 5.5\text{V}$	$T_A = 25^\circ\text{C}$	-0.25	0.15	0.25	
			$T_J = -40^\circ\text{C}$ to $+125^\circ\text{C}$	-0.35		0.35	
		$V_{OUT} = 3.0\text{V}$, $3.5\text{V} < V_{IN} < 5.5\text{V}$	$T_A = 25^\circ\text{C}$	-0.25	0.15	0.25	
			$T_J = -40^\circ\text{C}$ to $+125^\circ\text{C}$	-0.35		0.35	
		$V_{OUT} = 3.3\text{V}$, $3.8\text{V} < V_{IN} < 5.5\text{V}$	$T_A = 25^\circ\text{C}$	-0.2	0.1	0.2	
			$T_J = -40^\circ\text{C}$ to $+125^\circ\text{C}$	-0.3		0.3	
Output Current	I_{OUT}	(See Note2)	250			mA	
Output Current Limit	I_{LIM}	$V_{OUT} = 0\text{V}$, $T_A = 25^\circ\text{C}$	300	350	750	mA	
Quiescent Current	I_Q	$10\mu\text{A} < I_{OUT} < 250\text{mA}$	$T_A = 25^\circ\text{C}$		17	25	μA
		$10\mu\text{A} < I_{OUT} < 250\text{mA}$	$T_J = -40^\circ\text{C}$ to $+125^\circ\text{C}$			30	
Output Voltage Load Regulation $\frac{DV_{OUT}}{V_{OUT}} \times 100\%$ $D I_{OUT}$	REG _{LOAD}	$1\text{mA} \leq I_{OUT} \leq 250\text{mA}$	$T_A = 25^\circ\text{C}$	-0.1	0.0025	0.1	%/ mA

Note1 : $V_{IN} = V_{OUT} + V_{DROP}$

Note2 : Continuous output current and operating junction temperature are limited by internal protection circuitry, but it is not recommended that the device operate under conditions beyond those specified in this table for extended periods of time.

AME8821

■ Electrical Specifications (contd.)

Parameter	Symbol	Test Condition		Min	Typ	Max	Units
Dropout Voltage @ $V_{OUT} = V_{OUT(nom)} - 2\%V_{OUT(nom)}$	V_{DROP}	$V_{OUT(nom)} = 1.8V$ $I_{OUT} = 250mA$	$T_A = 25^\circ C$		1000	1100	mV
			$T_J = -40^\circ C$ to $+125^\circ C$			1200	
		$V_{OUT(nom)} = 2.5V$ $I_{OUT} = 250mA$	$T_A = 25^\circ C$		500	600	
			$T_J = -40^\circ C$ to $+125^\circ C$			650	
		$V_{OUT(nom)} = 2.85V$ $I_{OUT} = 250mA$	$T_A = 25^\circ C$		400	550	
			$T_J = -40^\circ C$ to $+125^\circ C$			600	
$V_{OUT(nom)} = 3V$ $I_{OUT} = 250mA$	$T_A = 25^\circ C$		400	550			
	$T_J = -40^\circ C$ to $+125^\circ C$			600			
$V_{OUT(nom)} = 3.3V$ $I_{OUT} = 250mA$	$T_A = 25^\circ C$		400	550			
	$T_J = -40^\circ C$ to $+125^\circ C$			600			
Thermal Shutdown Temperature	T_{SHDN}	Thermal shutdown increasing			150		$^\circ C$
Temperature Hysteresis	T_{HYS}				20		
Output Voltage Temperature Coefficient	T_C				30		ppm
Power Supply Ripple Rejection	PSRR	$V_{OUT} = 3.3V, f = 1KHz,$ $I_{OUT} = 100mA$ $C_{OUT} = 4.7\mu F$ $C_{(SR)} = 0.01\mu F$	$T_A = 25^\circ C$		65		dB
Output Voltage Noise	e_N	BW = 200Hz to 100KHz $I_{OUT} = 250mA$ $C_{OUT} = 4.7\mu F,$ $C_{(SR)} = 0.47\mu F$	$T_A = 25^\circ C$		100		μV_{RMS}
Enable Bar High (Shutdown)	$V_{ENB(HI)}$	$V_{IN} = 2.5V$ to $5.5V$		1.4		V_{IN}	V
Enable High (Enabled)	$V_{EN(HI)}$						
Enable Bar Low (Enabled)	$V_{ENB(LO)}$			0		0.3	
Enable Low (Shutdown)	$V_{EN(LO)}$						
Enable / Enable Bar Pin Current (Enabled)	I_{EN} / I_{ENB}	ENB = 0, EN = V_{IN} , $V_{IN} = 2.5V$ to $5.5V$			0.1	1	μA
Shutdown Current	I_{SHDN}	ENB = V_{IN} , EN = 0, $V_{IN} = 2.5V$ to $5.5V$			1	2	μA
Start up Time	T_{STR}	$V_{OUT} = 3.3V$ $R_{LOAD} = 22\Omega$ $C_{OUT} = 10\mu F$	$C_{(SR)} = 0.01\mu F$	$T_A = 25^\circ C$		20	mS
			$C_{(SR)} = 0.1\mu F$			200	
			$C_{(SR)} = 0.22\mu F$			450	

AME8821

■ Detail Description

The AME8821 family of CMOS regulators contain a PMOS pass transistor, voltage reference, error amplifier, over-current protection, and thermal shutdown function.

The P-channel pass transistor receives data from the error amplifier, over-current limit, and thermal protection circuits. During normal operation, the error amplifier compares the output voltage to a precision reference. Over-current and thermal shutdown circuits become active when the junction temperature exceeds 150°C, or the current exceeds about 350mA. During thermal shutdown, the output voltage remains low. Normal operation is restored when the junction temperature drops below 130°C.

The AME8821 switches from voltage mode to current mode when the load exceeds the rated output current. This prevents over-stress.

■ External Capacitors

The AME8821 is stable with an output capacitor to ground of 4.7 μ F or greater. Ceramic capacitors have the lower ESR, and will offer the best AC performance. Conversely, Aluminum Electrolytic capacitors exhibit the higher ESR, resulting in the poor AC response. Unfortunately, large value ceramic capacitors are comparatively expensive. One option is to parallel a 0.1 μ F ceramic capacitor with a 10 μ F Aluminum Electrolytic. The benefit is low ESR, high capacitance, and low overall cost.

A second capacitor is recommended between the input and ground to stabilize V_{IN} . The input capacitor should be at least 1 μ F to have a beneficial effect. All capacitors should be placed in close proximity to the pins. A "Quiet" ground termination is desirable. This can be achieved with a "Star" connection

■ Enable

The Enable pin is optional. EN for active high enable, ENB for active low enable. When disable the Enable Pin $EN = 0$, $ENB = V_{IN}$, the PMOS pass transistor shuts off, and all internal circuits are powered down. In this state, the standby current is less than 1 μ A.

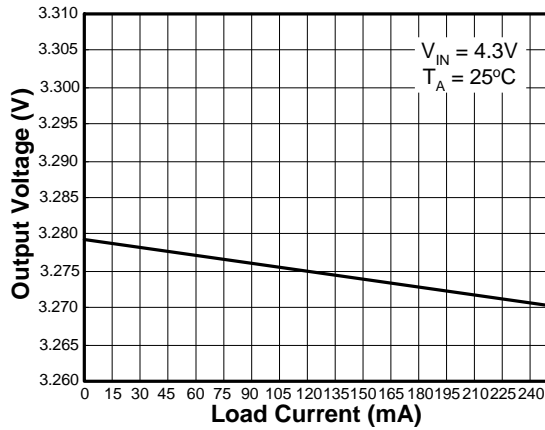
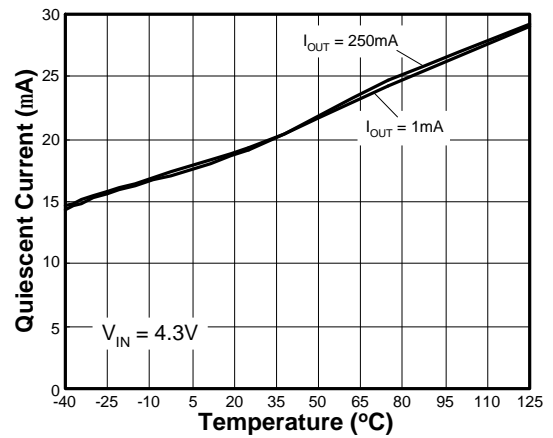
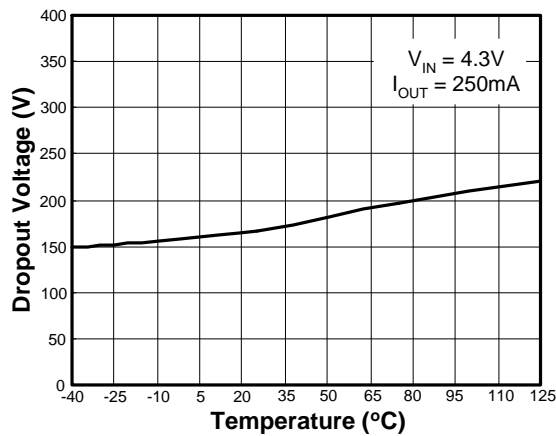
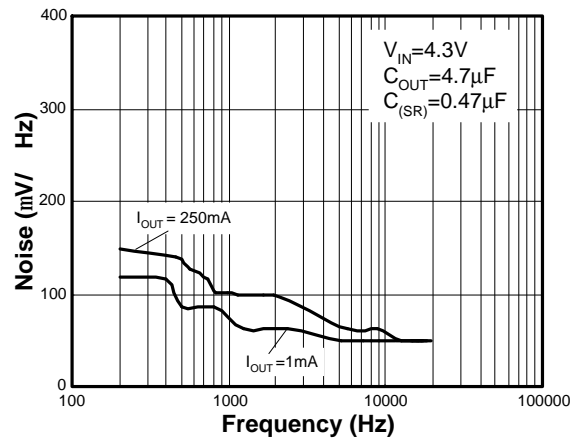
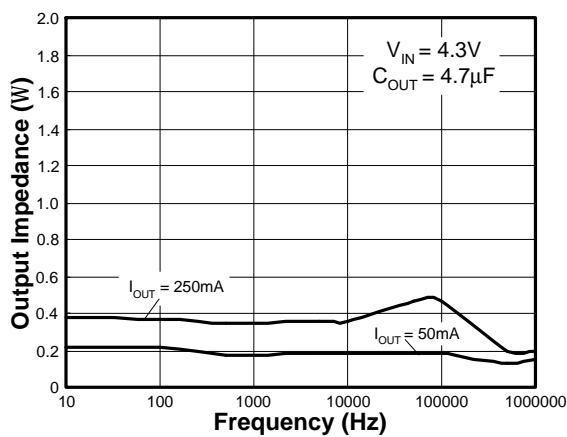
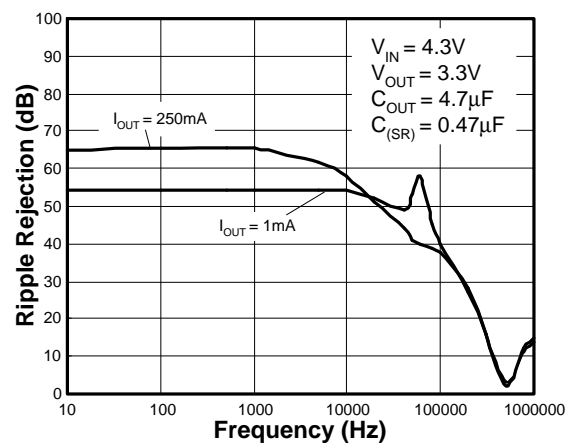
Output Voltage vs Load Current

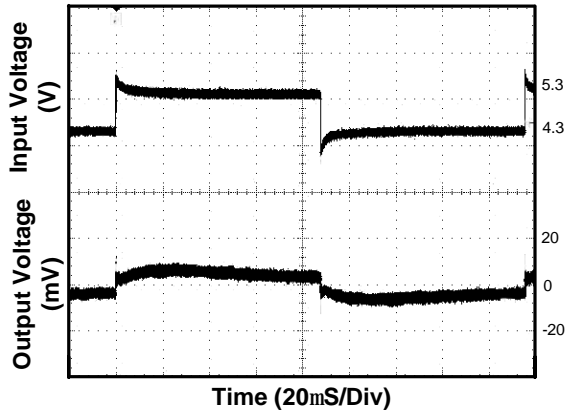
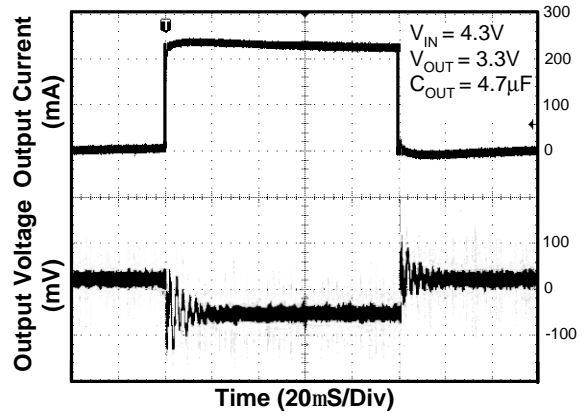
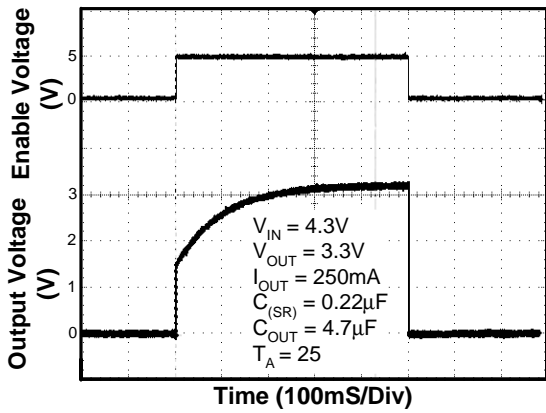
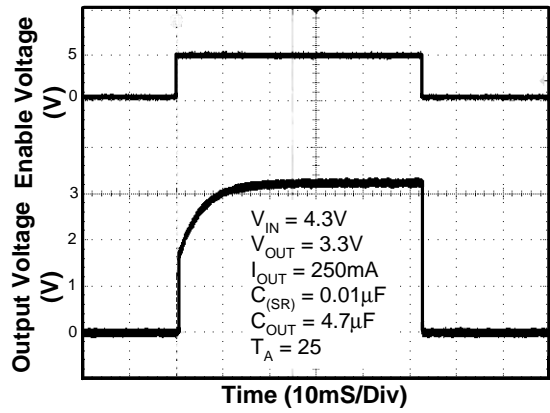
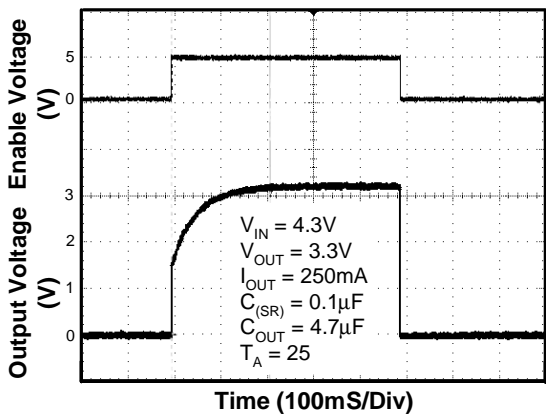
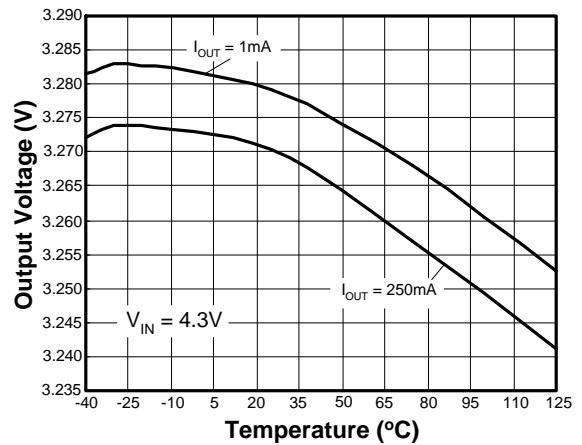
Quiescent Current vs Temperature

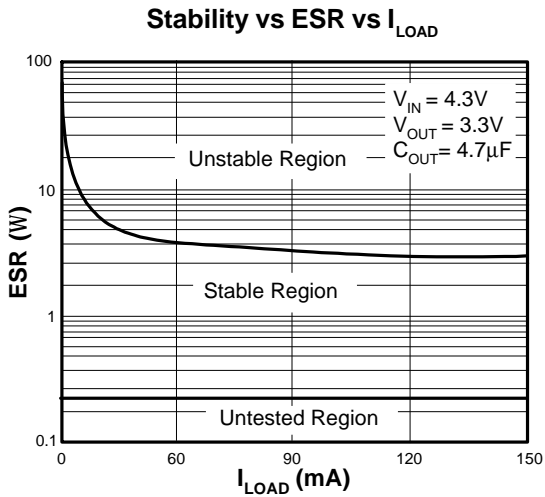
Dropout Voltage vs. Temperature

Output Spectral Noise Density vs. Frequency

Output Impedance vs. Frequency

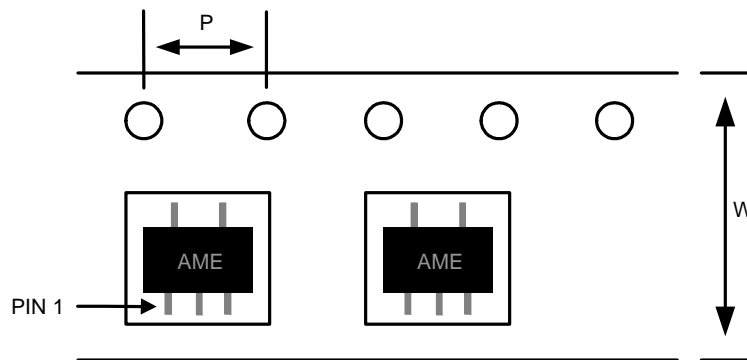
Power Supply Ripple Rejection Ratio

Line Transient Response

Load Transient Response

Output Voltage, Enable Voltage vs Time (Start-Up)

Output Voltage, Enable Voltage vs Time (Start-Up)

Output Voltage, Enable Voltage vs Time (Start-Up)

Output Voltage vs. Temperature



■ Date Code Rule

Marking			Date Code		Year
A	A	A	W	W	xxx0
A	A	A	W	<u>W</u>	xxx1
A	A	A	<u>W</u>	W	xxx2
A	A	A	<u>W</u>	<u>W</u>	xxx3
A	A	<u>A</u>	W	W	xxx4
A	A	<u>A</u>	W	<u>W</u>	xxx5
A	A	<u>A</u>	<u>W</u>	W	xxx6
A	A	<u>A</u>	<u>W</u>	<u>W</u>	xxx7
A	<u>A</u>	A	W	W	xxx8
A	<u>A</u>	A	W	<u>W</u>	xxx9

■ Tape and Reel Dimension
SOT-25

Carrier Tape, Number of Components Per Reel and Reel Size

Package	Carrier Width (W)	Pitch (P)	Part Per Full Reel	Reel Size
SOT-25	8.0±0.1 mm	4.0±0.1 mm	3000pcs	180±1 mm

AME8821
■ Tape and Reel Dimension

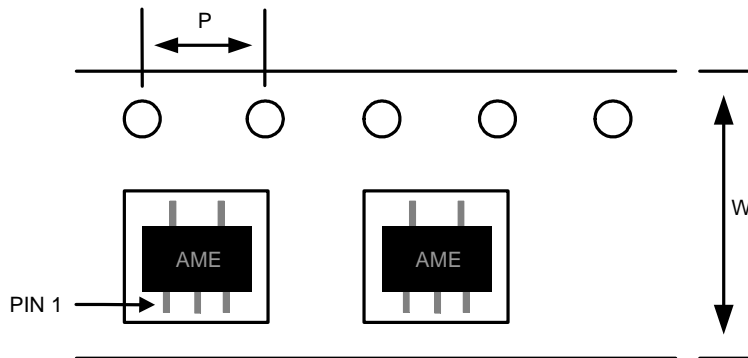
TSOT-25



Carrier Tape, Number of Components Per Reel and Reel Size

Package	Carrier Width (W)	Pitch (P)	Part Per Full Reel	Reel Size
TSOT-25	8.0±0.1 mm	4.0±0.1 mm	3000pcs	180±1 mm

AME8821

■ Package Dimension

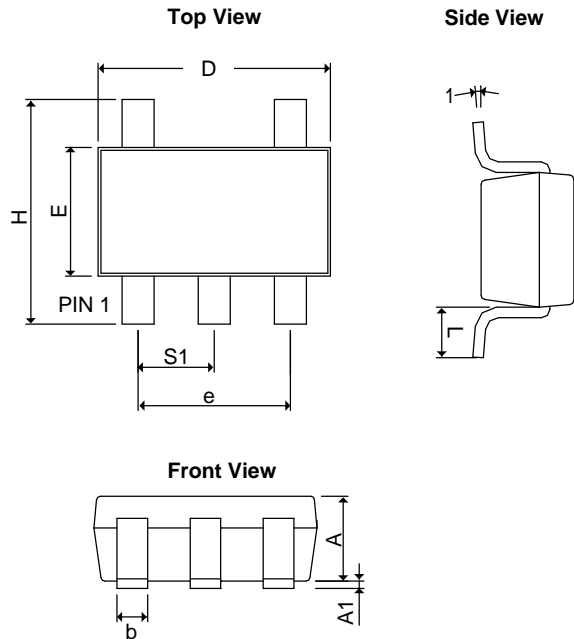
SOT-25



SYMBOLS	MILLIMETERS		INCHES	
	MIN	MAX	MIN	MAX
A	1.20REF		0.0472REF	
A ₁	0.00	0.15	0.0000	0.0059
b	0.30	0.55	0.0118	0.0217
D	2.70	3.10	0.1063	0.1220
E	1.40	1.80	0.0551	0.0709
e	1.90 BSC		0.07480 BSC	
H	2.60	3.00	0.10236	0.11811
L	0.37BSC		0.0146BSC	
q1	0°	10°	0°	10°
S ₁	0.95BSC		0.0374BSC	

TSOT-25

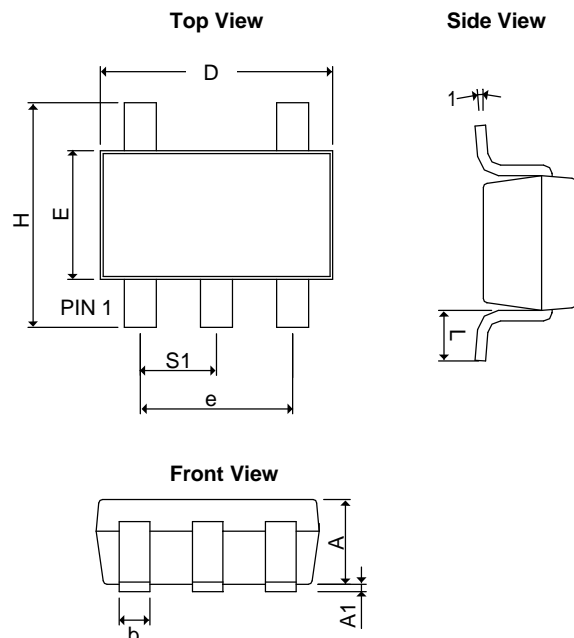

SYMBOLS	MILLIMETERS		INCHES	
	MIN	MAX	MIN	MAX
A+A ₁	0.90	1.25	0.0354	0.0492
b	0.30	0.50	0.0118	0.0197
D	2.70	3.10	0.1063	0.1220
E	1.40	1.80	0.0551	0.0709
e	1.90 BSC		0.07480 BSC	
H	2.40	3.00	0.09449	0.11811
L	0.35BSC		0.0138BSC	
q1	0°	10°	0°	10°
S ₁	0.95BSC		0.0374BSC	



www.ame.com.tw
E-Mail: sales@ame.com.tw

Life Support Policy:

These products of AME, Inc. are not authorized for use as critical components in life-support devices or systems, without the express written approval of the president of AME, Inc.

AME, Inc. reserves the right to make changes in the circuitry and specifications of its devices and advises its customers to obtain the latest version of relevant information.

© AME, Inc. , November 2008

Document: 1009-DS8821-A.04

Corporate Headquarter

AME, Inc.

2F, 302 Rui-Guang Road, Nei-Hu District
Taipei 114, Taiwan.

Tel: 886 2 2627-8687

Fax: 886 2 2659-2989