

240-790-071
Series 79 Filtered Receptacle
Rear Panel Mount with Solder Cup Termination

How To Order Filter Series 79 Connectors

Sample Part Number	240-790-071	P	H-66	ME	P	D	P
Series	240-790-071						
Contact Type	P - Pin Contacts						
Insert Arrangement	(See Table I)						
Shell Material/Finish	Aluminum Shell ME - Electroless Nickel MT - Nickel-PTFE E - Chem Film Z2 - Gold UC - Zinc Cobalt with Black Chromate J - Cadmium with Yellow Chromate NF - Cad/O.D. over Electroless Nickel						
Filter Type	C - C Filter P - Pi Filter						
Filter Class	X, Y, Z, A, B, C, D, E, F, G, J (See Table II)						
Mating Hardware Options	P - Jackposts G - Male Guide Pins S - Female Guide Sockets N - No Mating Hardware (See Table)						

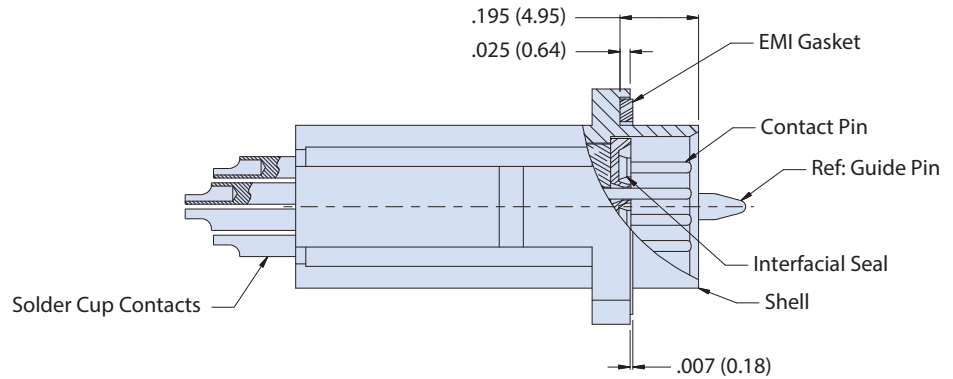
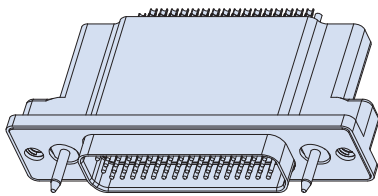

Notes

1. Assembly to be identified with Glenair's name, part number, and date code, space permitting
2. EMI Filtered receptacle connector designed to meet requirements of MIL-STD-2120 and Glenair Series 79 specifications. Unless otherwise specified herein, refer to Glenair specification 799-008 for additional performance characteristics.
3. All contacts to have identical filter value. Other filter arrangements available, contact factory
4. Dielectric Withstanding Voltage: 500 VDC (Filter Class X, Y, Z are 250 VDC)
5. Insulation Resistance: 5,000 megohms @ 200 VDC

6. Current Carrying Capacity
23 Gage - 5 Amps max. for all layouts
16 Gage - 7.5 Amps max. for combo layouts / 13 Amps max. for all-power layouts
12 Gage - 13 Amps max. for combo layouts / 23 Amps max. for all-power layouts
7. Other filter styles (C-L, L-C, Unbalanced Pi, Multi-Stage, Multi-Value) are available. Please consult factory with your requirements.

Materials/Finishes:

Insulators - High Grade Rigid Dielectric / N.A.
Interfacial Seal - Fluorosilicone Elastomer / N.A.
Contacts - Copper Alloy / 50 microinches Gold over Nickel
Mating Hardware - 300 Series Stainless Steel / Passivated
EMI Gasket - Silver-Filled Fluorosilicone, CHO-SEAL 1287

Dimensions in inches (millimeters) and are subject to change without notice.

240-790-071
Series 79 Filtered Receptacle
 Rear Panel Mount with Solder Cup Termination



Table I: Contact Arrangements

Layout	Contact Quantity			Face View
	#23	#16	#12	
A-5	5			
B-2P2		2		
B-9	9			
C-13	13			
D-15	15			
D-3P3		3		
D-7P2	5	2		
E-11P2	9	2		
E-19	19			
E-7P3	4	3		
F-15P2	13	2		
F-23	23			
F-5P5		5		
G-33	33			
H-10P4	6		4	
H-29P7	22	7		
H-36P2	34		2	
H-54P2	52	2		
H-5P5			5	
H-66	66			
J-17P4	13	4		
J-25P2	23	2		
J-33	33			
J-7P7		7		
K-27P4	23	4		
K-35P2	33	2		
K-43	43			
K-9P9		9		
L-6P6			6	
L-78	78			
M-102	102			

Table II: Capacitor Array Code / Capacitance Range

Class	Pi - Circuit (pF)	C - Circuit (pF)
X*†	160,000 - 240,000	80,000 - 120,000
Y*	80,000 - 120,000	40,000 - 60,000
Z*	60,000 - 90,000	30,000 - 45,000
A	38,000 - 56,000	19,000 - 28,000
B	32,000 - 45,000	16,000 - 22,500
C	18,000 - 33,000	9,000 - 16,500
D	8,000 - 12,000	4,000 - 6,000
E	3,300 - 5,000	1,650 - 2,500
F	800 - 1,300	400 - 650
G	400 - 600	200 - 300
J	70-120	35-60

* Filter Classes X, Y and Z are 250 VDC.
 All others are 500 VDC
 † Class X filters not available for insert arrangements with 3 or more rows of contacts

Blind mate

SHELL SIZES A, B, C, D, E, F, G, J, K

± .030 (0.76) Allowable misalignment from centerline

SHELL SIZES H, L

± .040 (1.02) Allowable misalignment from centerline

SHELL SIZE M

± .050 (1.27) Allowable misalignment from centerline



Table III: Hardware Option

N No Mating Hardware		Connector supplied with blind tapped holes. .150" (3.8 mm) minimum depth. Shell size M has #8-32 UNC-2B thread. Shell sizes H and L have #6-32 UNC-2B thread. All other sizes have #4-40 UNC-2B thread.
P Jackposts		Connector is supplied with non-removable stainless steel jackposts. Shell size M has 6-32-UNC thread. Shell sizes H and L have #4-40 UNC-2B thread. All other sizes have #2-56 UNC-2B thread.
G Guide Pins		Connector is supplied with stainless steel non-removable guide pins for blind mate applications. Mates with type "S" guide sockets on corresponding plug connector.
S Guide Sockets		Connector is supplied with stainless steel non-removable bushings for blind mate applications. Mates with type "G" guide pins on corresponding plug connector.

Dimensions in inches (millimeters) and are subject to change without notice.

Series 79
Micro-Crimp

240-790-071
Series 79 Filtered Receptacle
Rear Panel Mount with Solder Cup Termination

240-790-071P SHELL SIZE A, B, C, D, E, F, J AND K DIMENSIONS

2-56 UNC-2B
X.150 (3.81) Min
2 Places

Jackpost Shown
For Reference
See Table III

.170 (4.32)

.093 ± .005
(2.36 ± 0.13)

.335 (8.51)
Max.

.860 (21.85)
Max.

E Max.

C Basic

.485 (12.32)
Max.

.215 (5.46)
Max.

2-56 UNC-2B
X.150 (3.81) Min
2 Places

.308 (7.82)
Max.

.150 (3.81) Min.
2X

#23ga For All Layouts
.200 ± .060 (5.08 ± 1.52)
#16ga In Combo Layouts
.250 ± .060 (6.35 ± 1.52)
#16ga In Power Layouts
.340 ± .060 (8.64 ± 1.52)

Shell Sizes A,B,C,D,E,F,J,K

790-071P Dimensions for Size A-F, J and K										
Shell Size	A Max.		B Basic		C Basic		D Max		E Max	
	In.	mm.	In.	mm.	In.	mm.	In.	mm.	In.	mm.
A	1.211	30.76	.925	23.50	.565	14.35	.401	10.19	.760	19.30
B	1.361	34.57	1.075	27.31	.715	18.16	.551	14.00	.910	23.11
C	1.511	38.38	1.225	31.12	.865	21.97	.701	17.81	1.060	26.92
D	1.611	40.92	1.325	33.66	.965	24.51	.801	20.35	1.160	29.46
E	1.761	44.73	1.475	37.47	1.115	28.32	.951	24.16	1.310	33.27
F	1.911	48.54	1.625	41.28	1.265	32.13	1.101	27.96	1.460	37.08
J	2.261	57.43	1.975	50.17	1.615	41.02	1.460	37.08	1.810	45.97
K	2.661	67.59	2.375	60.33	2.015	51.18	1.860	47.24	2.210	56.13

Dimensions in inches (millimeters) and are subject to change without notice.

© 2013 Glenair, Inc. U.S. CAGE Code 06324 Printed in U.S.A.

GLENAIR, INC. • 1211 AIR WAY • GLENDALE, CA 91201-2497 • 818-247-6000 • FAX 818-500-9912
www.glenair.com **G-52** **E-Mail: sales@glenair.com**

240-790-071
 Series 79 Filtered Receptacle
 Rear Panel Mount with Solder Cup Termination



Series 79
 Micro-Crimp

240-790-071P SHELL SIZE G DIMENSIONS

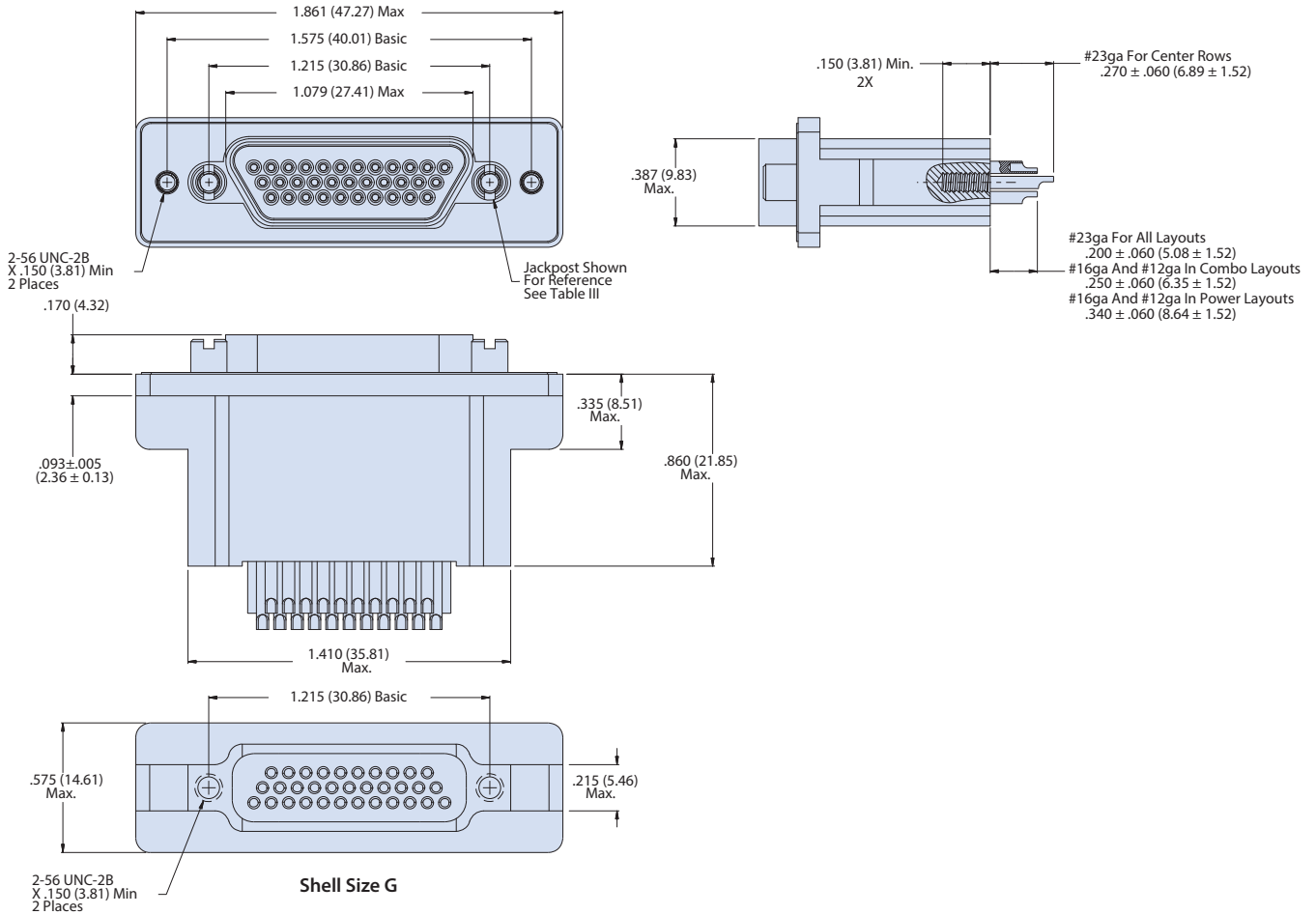

Dimensions in inches (millimeters) and are subject to change without notice.

© 2013 Glenair, Inc.

U.S. CAGE Code 06324

Printed in U.S.A.

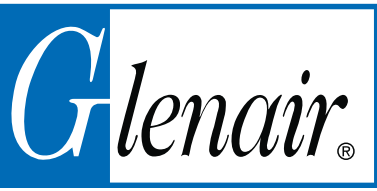

240-790-071P SHELL SIZE H AND L DIMENSIONS

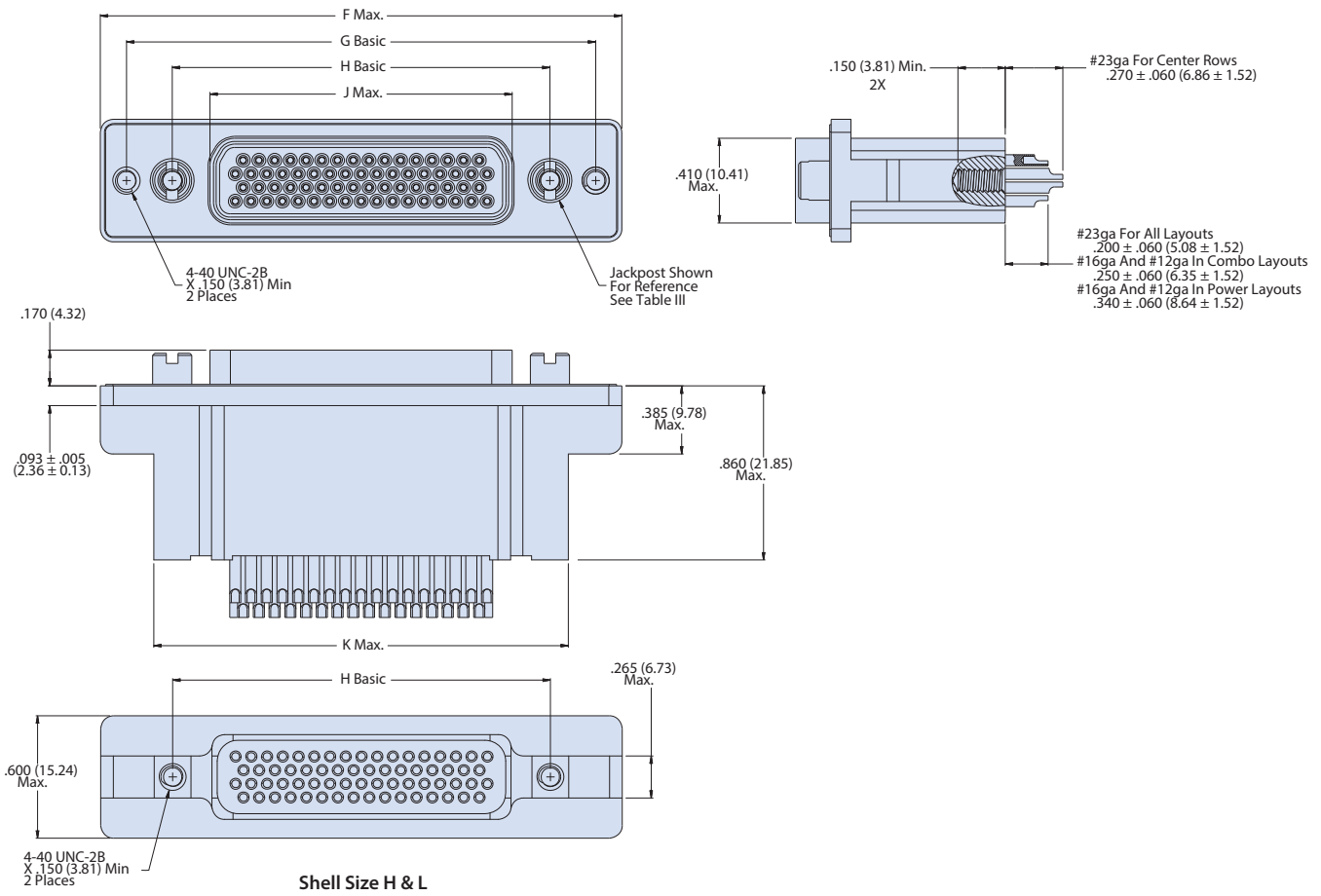

790-071P Size H & L Dimensions										
Shell Size	F Max		G Basic		H Basic		J Max		K Max	
	In.	mm.	In.	mm.	In.	mm.	In.	mm.	In.	mm.
H	2.500	63.50	2.236	56.79	1.800	45.72	1.450	36.83	2.045	51.94
L	2.736	69.49	2.472	62.79	2.036	51.71	1.686	42.82	2.281	57.94

Dimensions in inches (millimeters) and are subject to change without notice.

240-790-071
 Series 79 Filtered Receptacle
 Rear Panel Mount with Solder Cup Termination



Series 79
 Micro-Crimp

240-790-071P SHELL SIZE M DIMENSIONS

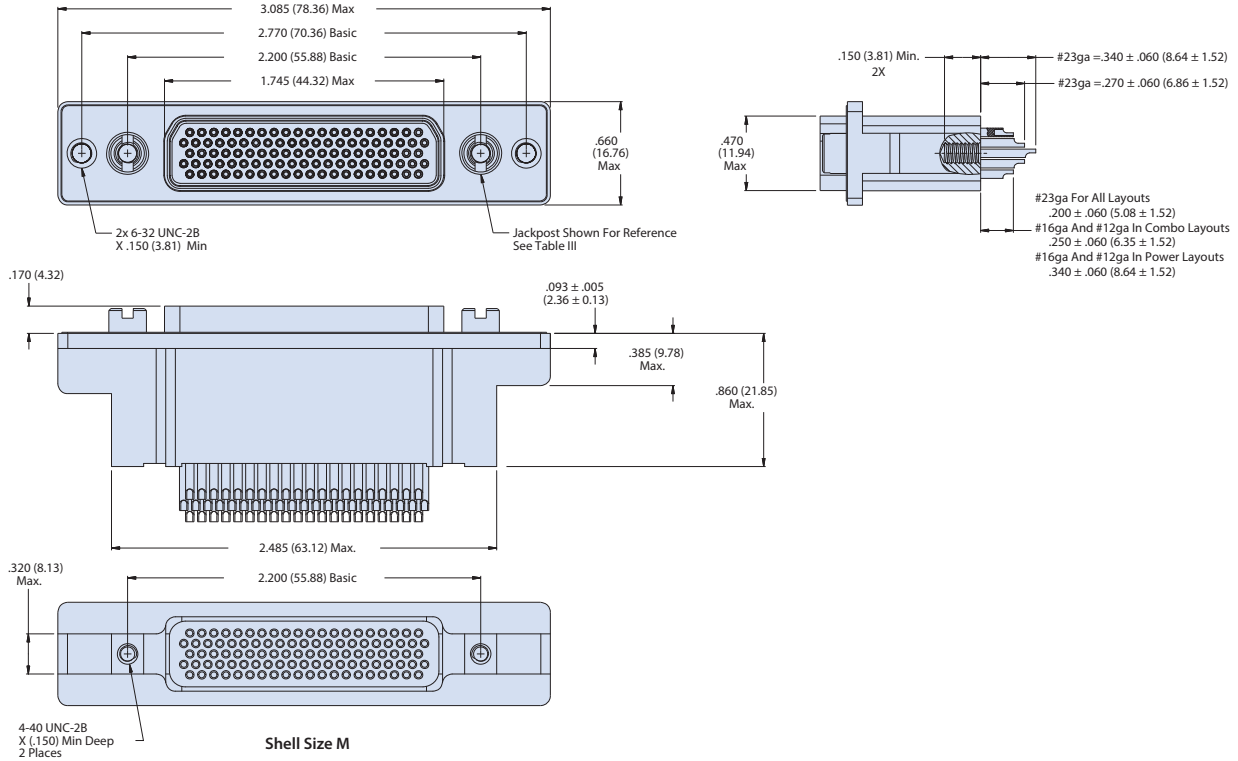

Dimensions in inches (millimeters) and are subject to change without notice.

© 2013 Glenair, Inc.

U.S. CAGE Code 06324

Printed in U.S.A.