



## PRODUCT SPECIFICATION

*Part Number*

PT804870G-TLMWD-EMC22

CUSTOMER	
CUSTOMER PART NUMBER	
DESCRIPTION	7.0" TFT LCD, Medium Brightness, CTP
APPROVED BY	
DATE	

**P-TEC****MODEL NO.****PAGE**

PT804870G-TLMWD-EMC22

SPEC SAMPLE

2

## 1. Table of Contents

<b>No.</b>	<b>Contents</b>	<b>Page</b>
1	Table of Contents	2
2	Record of Revisions	3
3	Module Numbering System	4
4	Application	5
5	Features	5
6	General Specifications	5
7	Absolute Maximum Ratings	6
8	Electrical Characteristics	7
9	Block Diagram	9
10	Input / Output Terminals Pin Assignment	10
11	Interface Timing	14
12	Optical Characteristics	24
13	Reliability Test	27
14	Packaging	28
15	Precautions	29
16	Outline Drawing	31
17	Definition of Labels	32
18	Incoming Inspection Standards	34





### 3. Module Numbering System

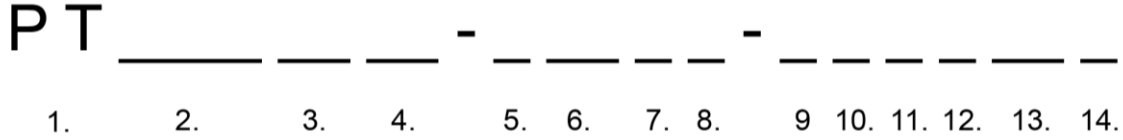

#### 1. P-TEC TFT

#### 8. VIEWING DIRECTION

D: 6 o'clock  
U: 12 o'clock  
F: Full Viewing Angle

#### 2. LENGTH x WIDTH PIXELS

If third character is a zero, it is removed to shorten part number. Example: 240 x 320 = PT3224

#### 9. A ~ Z CODE

Assigned by P-tec

#### 3. DIAGONAL DIMENSIONS

Example: 3.5" display = 35 in part number

#### 11. TEMPERATURE RANGE

Normal: Left Blank  
Wide: X

#### 4. PRODUCT VERSION

Series assigned by P-tec

#### 12. LUMINANCE

Blank: Normal (<300 nit)  
M: Middle (>= 300 nit)  
H: High (> 600 nit)

#### 5. LCD MODE

T: TN  
I: IPS  
V: VA

#### 13. TOUCH PANEL OPTION

No TP: Left Blank  
C: Capacitive TP  
R: Resistive TP

#### 6. POLARIZER

LM: Transmissive  
LF: Transflective

#### 14. SPECIAL CHARACTERS

Customer special requirements

#### 7. BACKLIGHT COLOR

No Backlight: Left Blank  
W: White  
B: Blue/Green  
S: Yellow/Green



#### 4. Application

This specification is applied to the 7 inch WVGA supported TFT-LCD module With projected capacitive touch (PCT) and can display true 262,144 colors (6 bit/ color). The module is designed for OA, Car TV application and other electronic products which require flat panel display of digital signal interface. This module is composed of a 7" TFT-LCD panel, a driver circuit and backlight unit and used as the input devices for general electric appliances via both finger and Capacitive stylus pen.

#### 5. Features

- WVGA (800×480 pixels) resolution.
- LVDS Receiver 18 bit Interface
- Dot inversion mode with stripe type.
- Projected Capacitive Touch
  - I<sup>2</sup>C Interface
  - Multi Touch (Ten points)

#### 6. General Specifications

Item	Specifications	Unit
Screen Size	7 (Diagonal)	inch
Display Format	800RGB(H)×480(V)	dot
Active Area	152.4(H)×91.44(V)	mm
Dot Size	0.0635(H)×0.1905(V)	mm
Pixel Configuration	RGB Vertical Stripe	-
Display Mode	TN Type Transmissive Mode Normally White	-
Surface Treatment	Clear(7H)	-
Viewing Direction	6 O'clock (The Gray Inversion will appear at this direction)	-
Outline Dimension	166.6(W)×109.4(H)×11.15(D)	mm
LVDS Receiver IC	THine THC63LVDF84B	-
Weight	228	g
RoHS Compliance	P-tec certifies this product to be in compliance with European Union Directive 2011/65/EU on the restriction of certain hazardous substances in electrical and electronic equipment.	-



## 7. Absolute Maximum Ratings

### 7.1 Absolute Ratings of Environment

Item	Symbol	Value		Unit	Note
		Min.	Max.		
Storage Temperature	T <sub>ST</sub>	-30	+80	°C	(1)(2)
Operating Ambient Temperature	T <sub>OP</sub>	-20	+70	°C	(1)(2)

Note1: Background color changes slightly depending on ambient temperature.

This phenomenon is reversible.

Note2: Please refer to item of RELIABILITY.

### 7.2 Electrical Absolute Ratings

#### 7.2.1 TFT-LCD Module

(Ta=25±2°C, GND=V<sub>SS</sub>=0V)

Item	Symbol	Value		Unit	Note
		Min.	Max.		
Digital Power Supply Voltage	V <sub>CC</sub>	-0.3	4.0	V	-
LVDS Driver Output Voltage	-	-0.3	V <sub>CC</sub> + 0.3	V	-

#### 7.2.2 Backlight Unit

(Ta=25±2°C)

Item	Symbol	Value		Unit	Note
		Min.	Max.		
Current of Backlight Unit	I <sub>B</sub>	-	250	mA	(1)
Voltage of Backlight Unit	V <sub>B</sub>	-	15	V	(1)

Note (1) Permanent damage to the device may occur if maximum values are exceeded or reverse voltage is loaded.

**8. Electrical Characteristics****8.1 TFT-LCD Module**

(Ta=25±2°C)

Item	Symbol	Value			Unit	Note
		Min.	Typ.	Max.		
Power Supply Voltage	V <sub>CC</sub>	3.0	3.3	3.6	V	-
Power Supply Current	I <sub>CC</sub>	-	215	305	mA	(1)
Differential Input High Threshold Voltage	V <sub>TH</sub>	-	-	100	mV	-
Differential Input Low Threshold Voltage	V <sub>TL</sub>	-100	-	-	mV	-
Power Consumption	P <sub>L</sub>	-	709.5	990	mW	(1)
VSYNC Frequency	F <sub>V</sub>	-	60	-	Hz	-
DCLK Frequency	DCLK	-	33.26	-	MHz	-

Note (1) The specified power consumption is under the conditions at V<sub>CC</sub>=3.3V, F<sub>V</sub>=60Hz, whereas a power dissipation check pattern below is displayed.

Black Pattern / 0 Gray



Active Area

**8.2 Backlight Unit**

(Ta=25±2°C)

Item	Symbol	Value			Unit	Note
		Min.	Typ.	Max.		
Current of Backlight Unit	I <sub>B</sub>	-	200	-	mA	-
Voltage of Backlight Unit	V <sub>B</sub>	-	9.9	-	V	I <sub>B</sub> =200mA
Power Consumption	P <sub>BL</sub>	-	(1.98)	-	W	I <sub>B</sub> =200mA
LED Life Time(25°C)	-	50000	-	-	hr	(1)

Note (1) : LED life time is defined as under 25±2°C , when the average brightness decrease to 50% of original brightness



### 8.3 Projected Capacitive Touch

Item	Symbol	Value			Unit	Note
		Min.	Typ.	Max.		
Operating Voltage	VDD	3.0	3.3	3.6	V	-
Power Supply Current	IDD	-	20.5	28.7	mA	(1)
Input High Threshold Voltage	V <sub>IH</sub>	0.7VDD	-	VDD	V	-
Input Low Threshold Voltage	V <sub>IL</sub>	-0.3	-	0.3VDD	V	-
Output High Threshold Voltage	V <sub>OH</sub>	0.7VDD	-	-	V	-
Output Low Threshold Voltage	V <sub>OL</sub>	-	-	0.3VDD	V	-
Power Consumption	P <sub>L</sub>	-	67.65	94.71	mW	@3.3V
Report Rate	R <sub>R</sub>	-	60	-	Hz	-
Interface		I <sup>2</sup> C				-
Function		Multi Touch				-

Note (1) This test condition is touched with 10 points.





## 9. Block Diagram

### 9.1 TFT-LCD Module with Backlight Unit

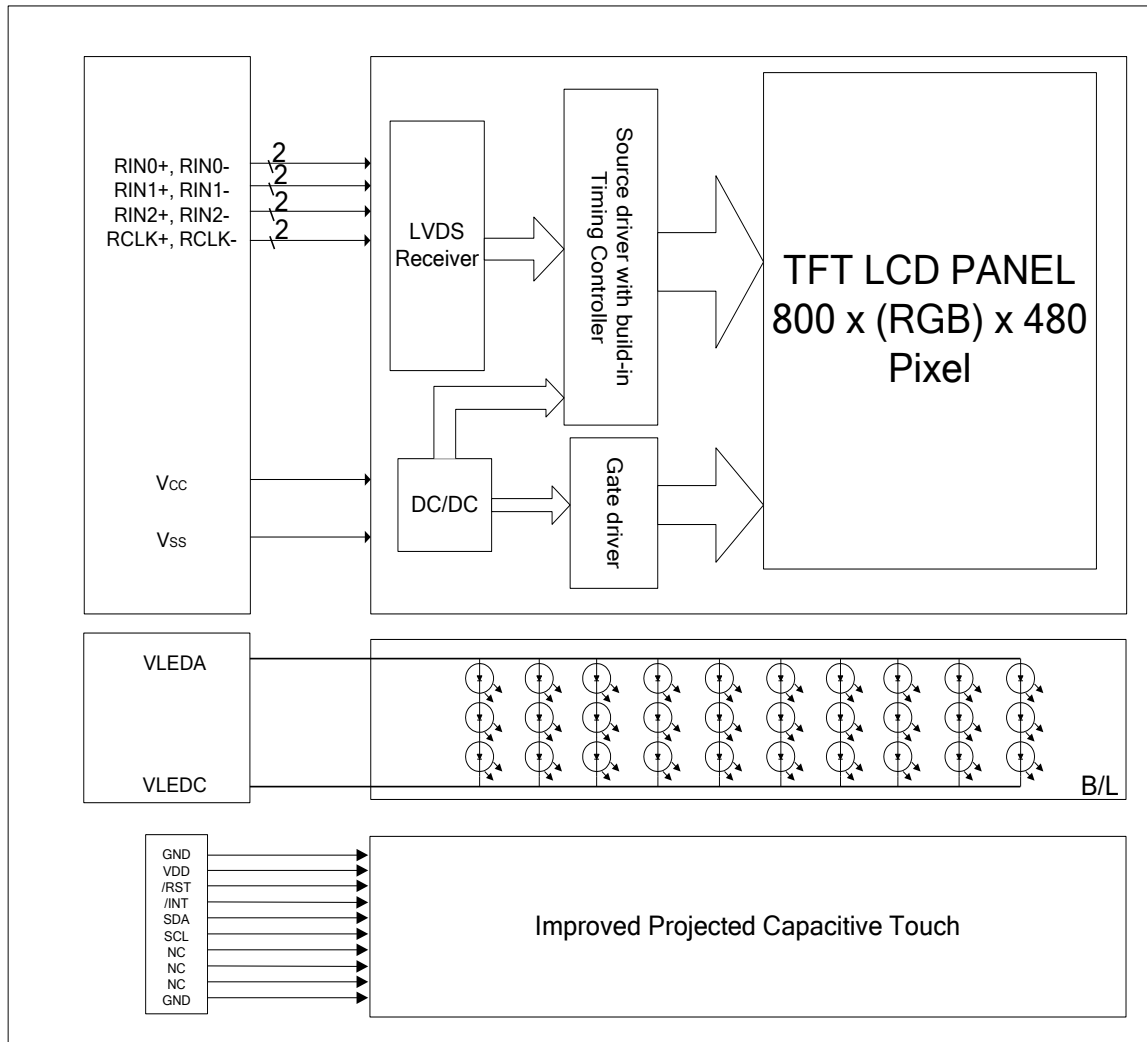



## 10. Input / Output Terminals Pin Assignment

### 10.1 TFT-LCD Module

Connector: HIROSE DF19K-20P-1H

Pin No.	Symbol	I/O	Description
1	Vcc	I	+3.3V power supply
2	Vcc	I	+3.3V power supply
3	Vss	I	Ground
4	Vss	I	Ground
5	RIN0-	I	Negative LVDS differential data input
6	RIN0+	I	Positive LVDS differential data input
7	Vss	I	Ground
8	RIN1-	I	Negative LVDS differential data input
9	RIN1+	I	Positive LVDS differential data input
10	Vss	I	Ground
11	RIN2-	I	Negative LVDS differential data input
12	RIN2+	I	Positive LVDS differential data input
13	Vss	I	Ground
14	RCLK-	I	Negative LVDS differential clock input
15	RCLK+	I	Positive LVDS differential clock input
16	Vss	I	Ground
17	NC	I	Not connection
18	NC	I	Not connection
19	Vss	I	Ground
20	Vss	I	Ground



## 10.2 Backlight Unit

Connector: JST BHSR-02VS-1(N)

Pin No.	Symbol	I/O	Description	Wire Color
1	VLEDA	I	Backlight LED Anode.	Red
2	VLEDC	I	Backlight LED Cathode.	Black

## 10.3 Improved Projected Capacitive Touch

Connector: CVILUX CF25101D0R0-05

Pin No.	Symbol	I/O	Description
1	GND	I	System ground.
2	VDD	I	+3.3V power supply.
3	/RST	I	External reset signal, active low.
4	/INT	O	Interrupt signal, active low, asserted to request Host start a new transaction.
5	SDA	I/O	I <sup>2</sup> C data signal.
6	SCL	I	I <sup>2</sup> C clock signal.
7	NC	-	Not Connection
8	NC	-	Not Connection
9	NC	-	Not Connection
10	GND	I	System ground.



### 10.4 Color Data Input Assignment

The brightness of each primary color(red, green and blue) is based on the 6 bit gray scale data input for the color. The higher the binary input, the brighter the color. The table provides the assignment of color versus data input.

Color		Data Signal																	
		Red						Green						Blue					
		R5	R4	R3	R2	R1	R0	G5	G4	G3	G2	G1	G0	B5	B4	B3	B2	B1	B0
Basic Colors	Black	0	0	0	0	0	0	0	0	0	0	0	0	0	0	0	0	0	0
	Red	1	1	1	1	1	1	0	0	0	0	0	0	0	0	0	0	0	0
	Green	0	0	0	0	0	0	1	1	1	1	1	1	0	0	0	0	0	0
	Blue	0	0	0	0	0	0	0	0	0	0	0	0	1	1	1	1	1	1
	Cyan	0	0	0	0	0	0	1	1	1	1	1	1	1	1	1	1	1	1
	Magenta	1	1	1	1	1	1	0	0	0	0	0	0	0	1	1	1	1	1
	Yellow	1	1	1	1	1	1	1	1	1	1	1	1	0	0	0	0	0	0
	White	1	1	1	1	1	1	1	1	1	1	1	1	1	1	1	1	1	1
Gray Scale Of RED	Red(0) / Dark	0	0	0	0	0	0	0	0	0	0	0	0	0	0	0	0	0	0
	Red(1)	0	0	0	0	0	1	0	0	0	0	0	0	0	0	0	0	0	0
	Red(2)	0	0	0	0	1	0	0	0	0	0	0	0	0	0	0	0	0	0
	:	:	:	:	:	:	:	:	:	:	:	:	:	:	:	:	:	:	:
	:	:	:	:	:	:	:	:	:	:	:	:	:	:	:	:	:	:	:
	Red(61)	1	1	1	1	0	1	0	0	0	0	0	0	0	0	0	0	0	0
	Red(62)	1	1	1	1	1	0	0	0	0	0	0	0	0	0	0	0	0	0
	Red(63)	1	1	1	1	1	1	0	0	0	0	0	0	0	0	0	0	0	0
Gray Scale Of Green	Green(0) / Dark	0	0	0	0	0	0	0	0	0	0	0	0	0	0	0	0	0	0
	Green(1)	0	0	0	0	0	0	0	0	0	0	1	0	0	0	0	0	0	0
	Green(2)	0	0	0	0	0	0	0	0	0	1	0	0	0	0	0	0	0	0
	:	:	:	:	:	:	:	:	:	:	:	:	:	:	:	:	:	:	:
	:	:	:	:	:	:	:	:	:	:	:	:	:	:	:	:	:	:	:
	Green(61)	0	0	0	0	0	0	1	1	1	1	0	1	0	0	0	0	0	0
	Green(62)	0	0	0	0	0	0	1	1	1	1	1	0	0	0	0	0	0	0
	Green(63)	0	0	0	0	0	0	1	1	1	1	1	1	0	0	0	0	0	0
Gray Scale Of Blue	Blue(0) / Dark	0	0	0	0	0	0	0	0	0	0	0	0	0	0	0	0	0	0
	Blue(1)	0	0	0	0	0	0	0	0	0	0	0	0	0	0	0	0	0	1
	Blue(2)	0	0	0	0	0	0	0	0	0	0	0	0	0	0	0	0	1	0
	:	:	:	:	:	:	:	:	:	:	:	:	:	:	:	:	:	:	:
	:	:	:	:	:	:	:	:	:	:	:	:	:	:	:	:	:	:	:
	Blue(61)	0	0	0	0	0	0	0	0	0	0	0	0	1	1	1	1	0	1
	Blue(62)	0	0	0	0	0	0	0	0	0	0	0	0	1	1	1	1	1	0
	Blue(63)	0	0	0	0	0	0	0	0	0	0	0	0	1	1	1	1	1	1



### 10.5 Power ON/OFF Sequence

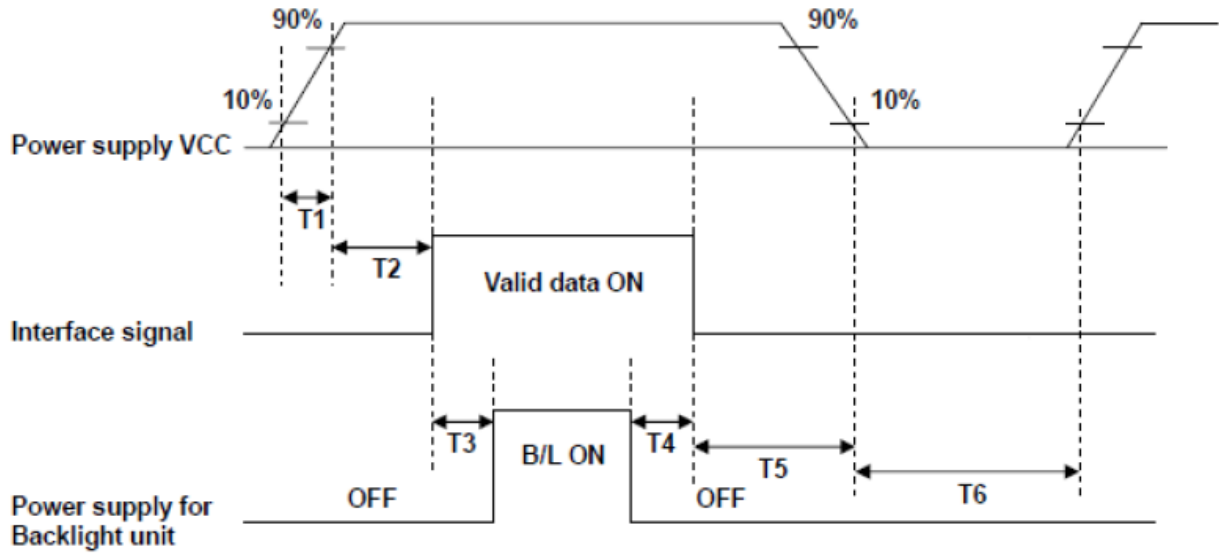

**POWER SEQUENCE TABLE**

Parameter	Value			Units
	Min.	Typ	Max.	
T1	0.5	-	10	ms
T2	0	-	50	ms
T3	500	-	-	ms
T4	500	-	-	ms
T5	0	-	50	ms
T6	1000	-	-	ms

**11. Interface Timing****11.1 Input Signal Characteristics**

PARAMETER	Symbol	Spec.			Unit
		Min.	Typ.	Max.	
DCLK frequency	$F_{CPH}$	-	33.26	-	MHz
DCLK period	$T_{CPH}$	-	30.06	-	ns
DCLK pulse duty	$T_{CWH}$	40	50	60	%
DE period	$T_{DEH}+T_{DEL}$	1000	1056	1200	$T_{CPH}$
DE pulse width	$T_{DEH}$	-	800	-	$T_{CPH}$
DE frame blanking	$T_{DEB}$	10	45	110	$T_{DEH}+T_{DEL}$
DE frame width	$T_{DE}$	-	480	-	$T_{DEH}+T_{DEL}$
Data setup time	$T_{dsu}$	6	-	-	ns
Data hold time	$T_{dhd}$	6	-	-	ns
DE setup time	$T_{esu}$	6	-	-	ns

**11.2 LVDS Switching Characteristics**

Symbol	Parameter	Min.	Typ.	Max.	Unit	
$t_{RCP}$	CLK OUT Period	VCC = 3.0 - 3.6V	11.76	T	50.0	ns
		VCC = 2.5 - 3.6V	14.28	T	50.0	ns
$t_{RCH}$	CLK OUT High Time		4T/7		ns	
$t_{RCL}$	CLK OUT Low Time		3T/7		ns	
$t_{RCD}$	RCLK +/- to CLK OUT Delay		5T/7		ns	
$t_{RS}$	TTL Data Setup to CLK OUT	0.35T-0.3			ns	
$t_{RH}$	TTL Data Hold from CKL OUT	0.45T-1.6			ns	
$t_{TLH}$	TTL Low to High Transition Time		2.0	3.0	ns	
$t_{THL}$	TTL High to Low Transition Time		1.8	3.0	ns	
$t_{RIP1}$	Input Data Position0 (T = 11.76ns)	-0.4	0.0	0.4	ns	
$t_{RIP0}$	Input Data Position1 (T = 11.76ns)	T/7-0.4	T/7	T/7+0.4	ns	
$t_{RIP6}$	Input Data Position2 (T = 11.76ns)	2T/7-0.4	2T/7	2T/7+0.4	ns	
$t_{RIP5}$	Input Data Position3 (T = 11.76ns)	3T/7-0.4	3T/7	3T/7+0.4	ns	
$t_{RIP4}$	Input Data Position4 (T = 11.76ns)	4T/7-0.4	4T/7	4T/7+0.4	ns	
$t_{RIP3}$	Input Data Position5 (T = 11.76ns)	5T/7-0.4	5T/7	5T/7+0.4	ns	
$t_{RIP2}$	Input Data Position6 (T = 11.76ns)	6T/7-0.4	6T/7	6T/7+0.4	ns	
$t_{RPLL}$	Phase Lock Loop Set			10.0	ms	



### 11.3 Waveform

#### 11.3.1 Clock and data input waveforms

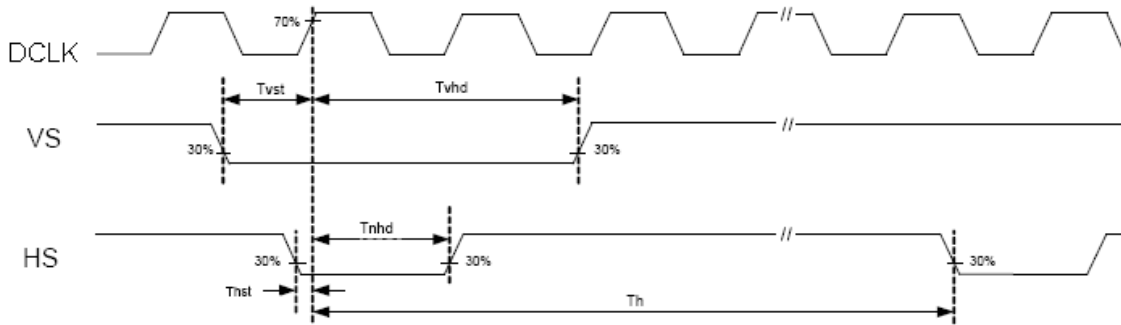
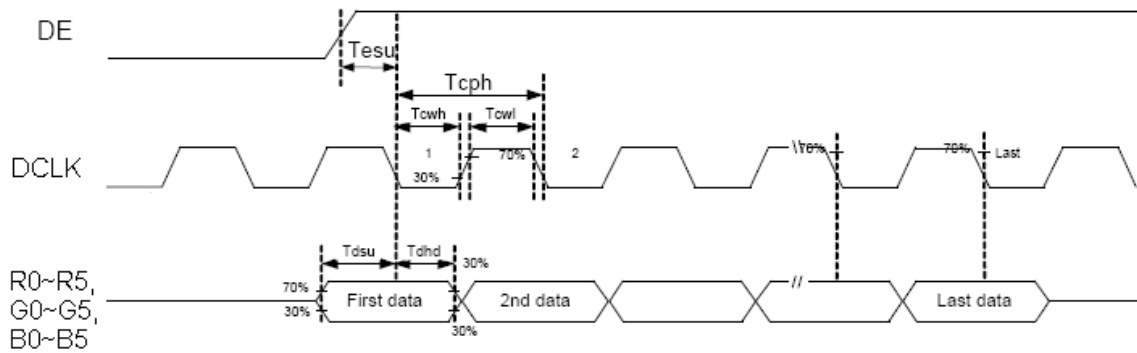

#### 11.3.2 Data input format

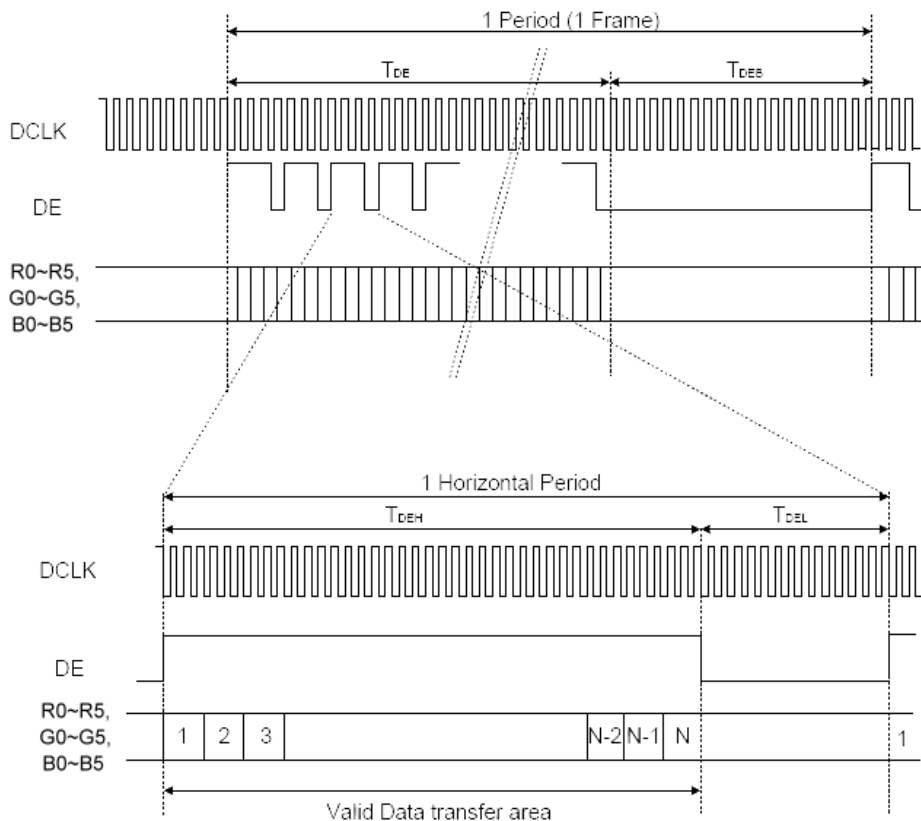



### 11.3.3 LVDS AC Timing

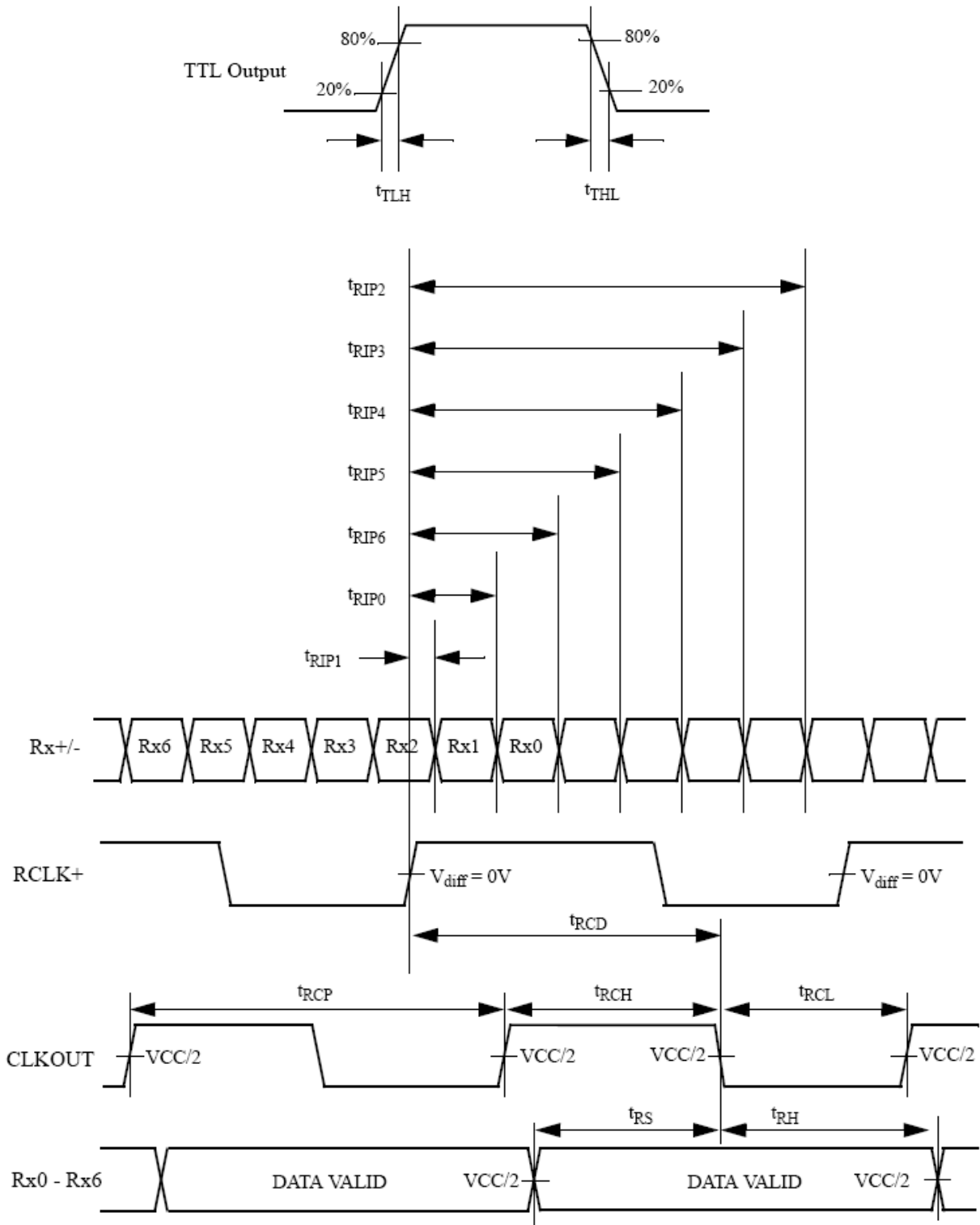

Note:

1)  $V_{diff} = (RA+) - (RA-), \dots, (RCLK+) - (RCLK-)$





## 11.4 Timing Requirement of Improved Projected Capacitive Touch

### 11.4.1 I2C Data Transfer Format

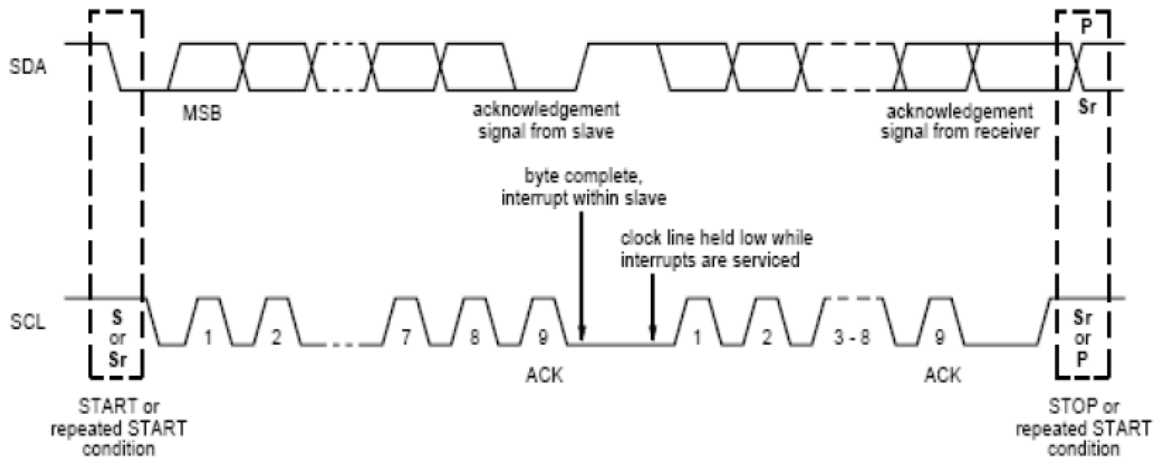

Mnemonics	Description
S	I <sup>2</sup> C Start or I <sup>2</sup> C Restart
A[6:0]	Slave Address = 7'b0111000
W	1'b0: Write
R	1'b1: Read
C	ACK
P	STOP: the indicate the end of a packet (if this bit is missing, S will indicate the end of the current packet and the beginning of the next packet)

#### Write N bytes to I2C slave

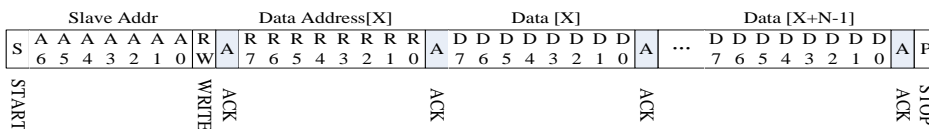

#### Set Data Address

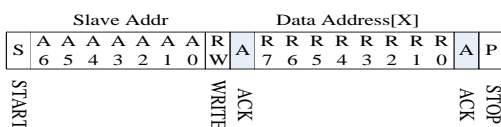

#### Read X bytes from I<sup>2</sup>C Slave

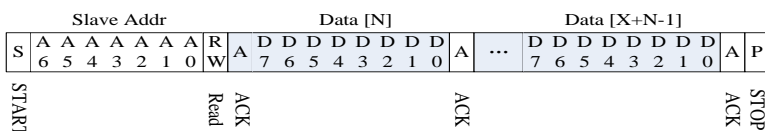



### 11.4.2 I2C Timing Characteristics

(Ta=25±2°C)

Parameter	Min	Max	Unit
SCL frequency	-	400	kHz
Bus free time between a STOP and START condition	4.7	-	μs
Hold time (repeated) START condition	4.0	-	μs
Data setup time	250	-	ns
Setup time for a repeated START condition	4.7	-	μs
Setup time for STOP condition	4.0	-	μs

### 11.4.3 Interrupt Trigger Mode

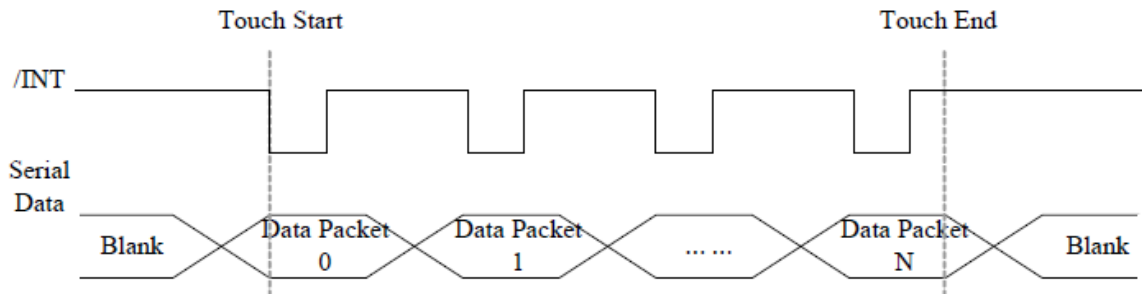

### 11.4.4 I2C Operating Mode Register Map

Address	Name	Bit 7	Bit 6	Bit 5	Bit 4	Bit 3	Bit 2	Bit 1	Bit 0	Host Access
Op,00h	DEVICE_MODE		Device Mode[2:0]							RW
Op,01h	Reserved									R
Op,02h	TD_STATUS					Number of touch points[3:0]				R
Op,03h	TOUCH1_YH	1 <sup>st</sup> Event Flag				1 <sup>st</sup> Touch Y Position[11:8]				R
Op,04h	TOUCH1_YL	1 <sup>st</sup> Touch Y Position[7:0]								R
Op,05h	TOUCH1_XH	1 <sup>st</sup> Touch ID[3:0]					1 <sup>st</sup> Touch X Position[11:8]			R
Op,06h	TOUCH1_XL	1 <sup>st</sup> Touch X Position[7:0]								R



Op,07h	Reserved			R
Op,08h	Reserved			R
Op,09h	TOUCH2_YH	2 <sup>nd</sup> Event Flag	2 <sup>nd</sup> Touch Y Position[11:8]	R
Op,0Ah	TOUCH2_YL	2 <sup>nd</sup> touch Y Position[7:0]		R
Op,0Bh	TOUCH2_XH	2 <sup>nd</sup> Touch ID[3:0]	2 <sup>nd</sup> Touch X Position[11:8]	R
Op,0Ch	TOUCH2_XL	2 <sup>nd</sup> Touch X Position[7:0]		R
Op,0Dh	Reserved			R
Op,0Eh	Reserved			R
Op,0Fh	TOUCH3_YH	3 <sup>rd</sup> Event Flag	3 <sup>rd</sup> Touch Y Position[11:8]	R
Op,10h	TOUCH3_YL	3 <sup>rd</sup> Touch Y Position[7:0]		R
Op,11h	TOUCH3_XH	3 <sup>rd</sup> Touch ID[3:0]	3 <sup>rd</sup> Touch X Position[11:8]	R
Op,12h	TOUCH3_XL	3 <sup>rd</sup> Touch X Position[7:0]		R
Op,13h	Reserved			R
Op,14h	Reserved			R
Op,15h	TOUCH4_YH	4 <sup>th</sup> Event Flag	4 <sup>th</sup> Touch Y Position[11:8]	R
Op,16h	TOUCH4_YL	4 <sup>th</sup> Touch Y Position[7:0]		R
Op,17h	TOUCH4_XH	4 <sup>th</sup> Touch ID[3:0]	4 <sup>th</sup> Touch X Position[11:8]	R
Op,18h	TOUCH4_XL	4 <sup>th</sup> Touch X Position[7:0]		R
Op,19h	Reserved			R
Op,1Ah	Reserved			R
Op,1Bh	TOUCH5_YH	5 <sup>th</sup> Event Flag	5 <sup>th</sup> Touch Y Position[11:8]	R
Op,1Ch	TOUCH5_YL	5 <sup>th</sup> Touch Y Position[7:0]		R
Op,1Dh	TOUCH5_XH	5 <sup>th</sup> Touch ID[3:0]	5 <sup>th</sup> Touch X Position[11:8]	R
Op,1Eh	TOUCH5_XL	5 <sup>th</sup> Touch X Position[7:0]		R
Op,1Fh	Reserved			R
Op,20h	Reserved			R
Op,21h	TOUCH6_YH	6 <sup>th</sup> Event Flag	6 <sup>th</sup> Touch Y Position[11:8]	R
Op,22h	TOUCH6_YL	6 <sup>th</sup> Touch Y Position[7:0]		R
Op,23h	TOUCH6_XH	6 <sup>th</sup> Touch ID[3:0]	6 <sup>th</sup> Touch	R



			X Position[11:8]	
Op,24h	TOUCH6_XL	6 <sup>th</sup> Touch X Position[7:0]		R
Op,25h	Reserved			R
Op,26h	Reserved			R
Op,27h	TOUCH7_YH	7 <sup>th</sup> Event Flag	7 <sup>th</sup> Touch Y Position[11:8]	R
Op,28h	TOUCH7_YL	7 <sup>th</sup> Touch Y Position[7:0]		R
Op,29h	TOUCH7_XH	7 <sup>th</sup> Touch ID[3:0]	7 <sup>th</sup> Touch X Position[11:8]	R
Op,2Ah	TOUCH7_XL	7 <sup>th</sup> Touch X Position[7:0]		R
Op,2Bh	Reserved			R
Op,2Ch	Reserved			R
Op,2Dh	TOUCH8_YH	8 <sup>th</sup> Event Flag	8 <sup>th</sup> Touch Y Position[11:8]	R
Op,2Eh	TOUCH8_YL	8 <sup>th</sup> Touch Y Position[7:0]		R
Op,2Fh	TOUCH8_XH	8 <sup>th</sup> Touch ID[3:0]	8 <sup>th</sup> Touch X Position[11:8]	R
Op,30h	TOUCH8_XL	8 <sup>th</sup> Touch X Position[7:0]		R
Op,31h	Reserved			R
Op,32h	Reserved			R
Op,33h	TOUCH9_YH	9 <sup>th</sup> Event Flag	9 <sup>th</sup> Touch Y Position[11:8]	R
Op,34h	TOUCH9_YL	9 <sup>th</sup> Touch Y Position[7:0]		R
Op,35h	TOUCH9_XH	9 <sup>th</sup> Touch ID[3:0]	9 <sup>th</sup> Touch X Position[11:8]	R
Op,36h	TOUCH9_XL	9 <sup>th</sup> Touch X Position[7:0]		R
Op,37h	Reserved			R
Op,38h	Reserved			R
Op,39h	TOUCH10_YH	10 <sup>th</sup> Event Flag	10 <sup>th</sup> Touch Y Position[11:8]	R
Op,3Ah	TOUCH10_YL	10 <sup>th</sup> Touch Y Position[7:0]		R
Op,3Bh	TOUCH10_XH	10 <sup>th</sup> Touch ID[3:0]	10 <sup>th</sup> Touch X Position[11:8]	R
Op,3Ch	TOUCH10_XL	10 <sup>th</sup> Touch X Position[7:0]		R
Op,3Dh	Reserved			R
Op,3Eh	Reserved			R

**11.4.5 DEVICE\_MODE**

This register is the device mode register, configure it to determine the current mode of the chip.

Address	Bit Address	Register Name	Description
Op,00h	6:4	Device Mode [2:0]	000b Normal operating Mode 001b System Information Mode (Reserved) 100b Test Mode – read raw data (Reserved)

**11.4.6 TD\_STATUS**

This register is the Touch Data status register.

Address	Bit Address	Register Name	Description
Op,02h	3:0	Number of touch points[3:0]	How many points detected. 1-10 is valid.

**11.4.7 TOUCHn\_YH (n:1-10)**

This register describes MSB of the Y coordinate of the nth touch point and the corresponding event flag.

Address	Bit Address	Register Name	Description
Op,03h ~ Op,39h	7:6	Event Flag	00b: Put Down 01b: Put Up 10b: Contact 11b: No event
	5:4		Reserved
	3:0	Touch Y Position [11:8]	MSB of Touch Y Position in pixels

**11.4.8 TOUCHn\_YL (n:1-10)**

This register describes LSB of the Y coordinate of the nth touch point.

Address	Bit Address	Register Name	Description
Op,04h ~ Op,3Ah	7:0	Touch Y Position [7:0]	LSB of the Touch Y Position in pixels

**11.4.9 TOUCHn\_XH (n:1-10)**

This register describes MSB of the X coordinate of the nth touch point and corresponding touch ID.

Address	Bit Address	Register Name	Description
Op,05h ~ Op,3Bh	7:4 3:0	Touch ID[3:0] Touch X Position [11:8]	Touch ID of Touch Point MSB of Touch X Position in pixels

**11.4.10 TOUCHn\_XL (n:1-10)**

This register describes LSB of the X coordinate of the nth touch point.

Address	Bit Address	Register Name	Description
Op,06h ~ Op,3Ch	7:0	Touch X Position [7:0]	LSB of The Touch X Position in pixels

**11.5 POWER ON/Reset Sequence**

Reset should be pulled down to be low before powering on and powering down. I2C shouldn't be used by other devices during Reset time after VDD powering on (Trtp). INT signal will be sent to the host after initializing all parameters and then start to report points to the host. If Power is down, the voltage of supply must be below 0.3V and Tpd is more than 1ms.

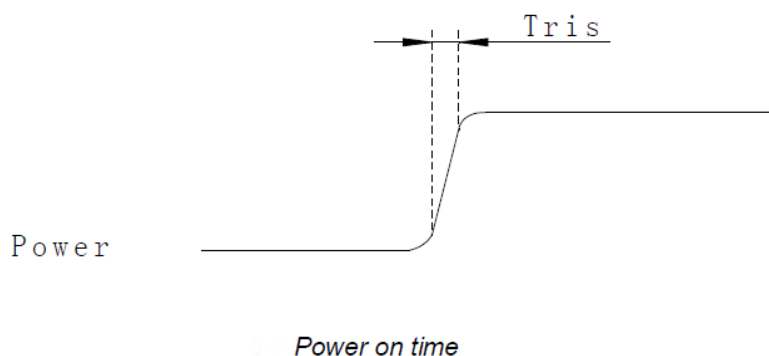

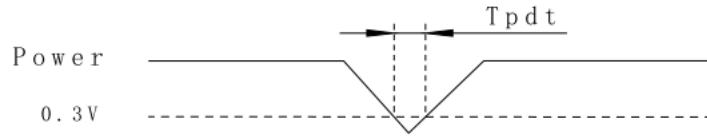

*Power Cycle requirement*

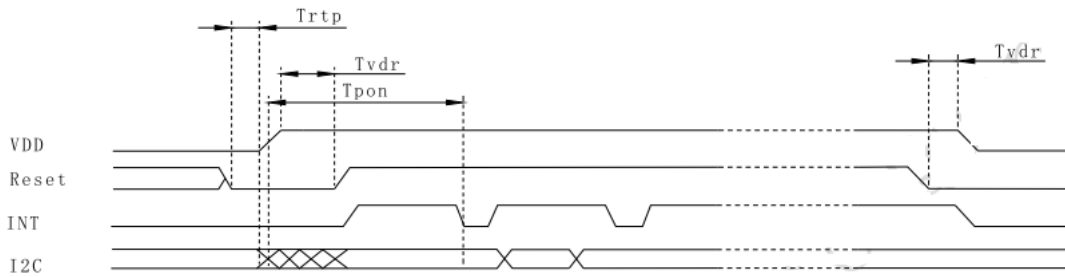

*Power on Sequence*

Reset time must be enough to guarantee reliable reset, the time of starting to report point after resetting approach to the time of starting to report point after powering on.

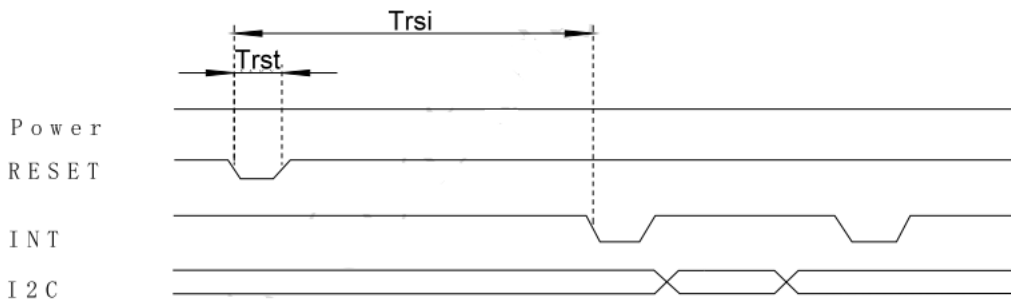

*Reset Sequence*

**Power on/Reset Sequence Parameters**

Parameter	Description	Min	Max	Units
Tris	Rise time from 0.1VDD to 0.9VDD	--	5	ms
Tpd t	Time of the voltage of supply being below 0.3V	5	--	ms
Trtp	Time of resetting to be low before powering on	100	--	μs
Tpon	Time of starting to report point after powering on	--	200	ms
Tvd r	Reset time after VDD powering on	1	--	ms
Trsi	Time of starting to report point after resetting	--	200	ms
Trst	Reset time	1	--	ms



## 12. Optical Characteristics

The optical characteristics should be measured in a dark environment ( $\leq 1$  lux) or equivalent state with the methods shown in Note (4).

Item		Symbol	Conditions	Min.	Typ.	Max.	Unit	Note
Contrast Ratio		CR	$\theta_x=0^\circ, \theta_y=0^\circ$ Viewing Normal Angle	150	( 250 )	-	-	(2)
Response Time		$T_R$		-	5	10	ms	(3)
		$T_F$		-	15	20	ms	
Luminance(Center)		Y		380	( 425 )	-	cd/m <sup>2</sup>	(4)
Brightness uniformity		BUNI		70	( 75 )	-	%	(5)
Color	Red	$R_x$		0.530	0.580	0.630	-	(1),(4)
		$R_y$		0.310	0.360	0.410	-	
Chromaticity	Green	$G_x$		0.300	0.350	0.400	-	
		$G_y$		0.530	0.580	0.630	-	
	Blue	$B_x$		0.100	0.150	0.200	-	
		$B_y$	0.090	0.140	0.190	-		
	White	$W_x$	0.270	0.320	0.370	-		
		$W_y$	0.300	0.350	0.400	-		
Viewing Angle	Horizontal	$\theta_{x+}$	55	( 65 )	-	deg.		
		$\theta_{x-}$	55	( 65 )	-			
	Vertical	$\theta_{y+}$	45	( 55 )	-			
		$\theta_{y-}$	55	( 65 )	-			





Note (1) Definition of Viewing Angle ( $\theta_x$ ,  $\theta_y$ ):

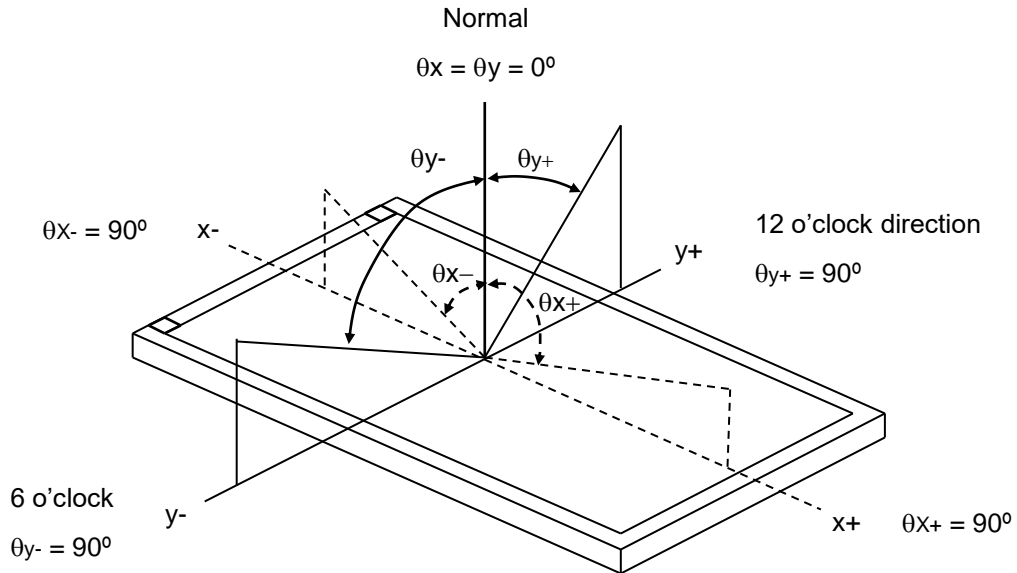

Note (2) Definition of Contrast Ratio (CR):

$$\text{Contrast ratio (CR)} = \frac{\text{Luminance measured when LCD on the "White" state}}{\text{Luminance measured when LCD on the "Black" state}}$$

Note (3) Definition of Response Time ( $T_R$ ,  $T_F$ ):

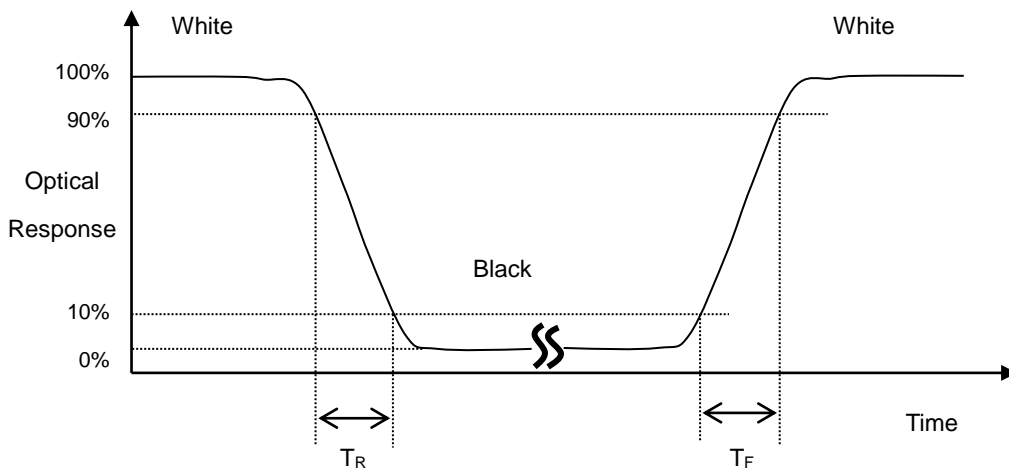



**Note (4) Measurement Set-Up:**

The LCD module should be stabilized at a given temperature for 30 minutes to avoid abrupt temperature change during measuring. In order to stabilize the luminance, the measurement should be executed after lighting Backlight for 30 minutes in a dark room or equivalent condition.

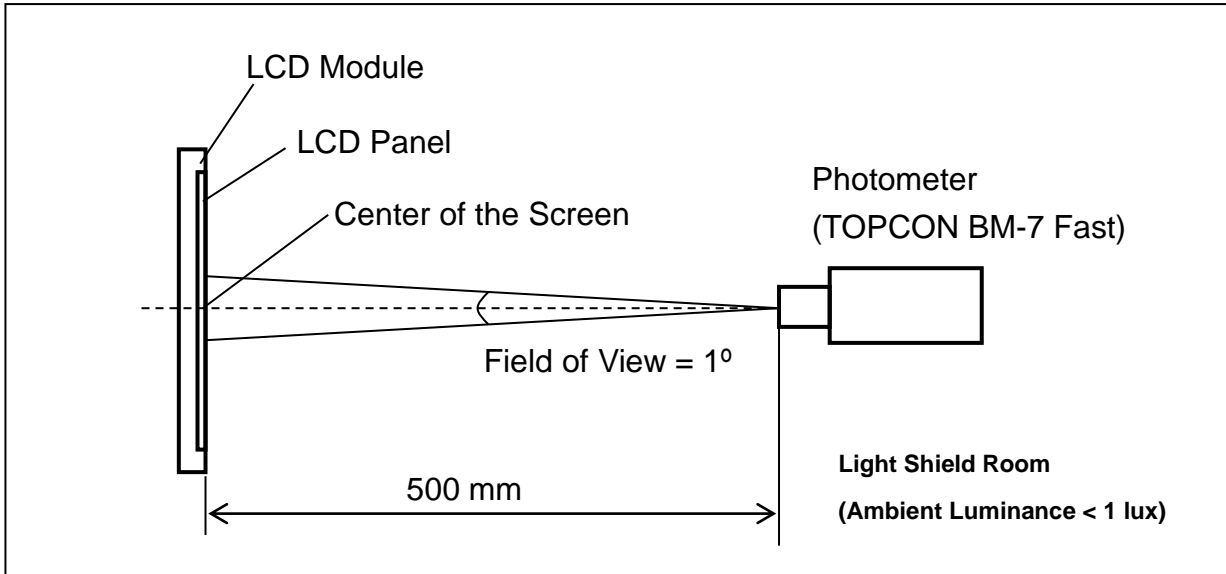

**Note (5) Definition of brightness uniformity**

Brightness uniformity=(Min Luminance of 9 points)/(Max Luminance of 9 points)×100%

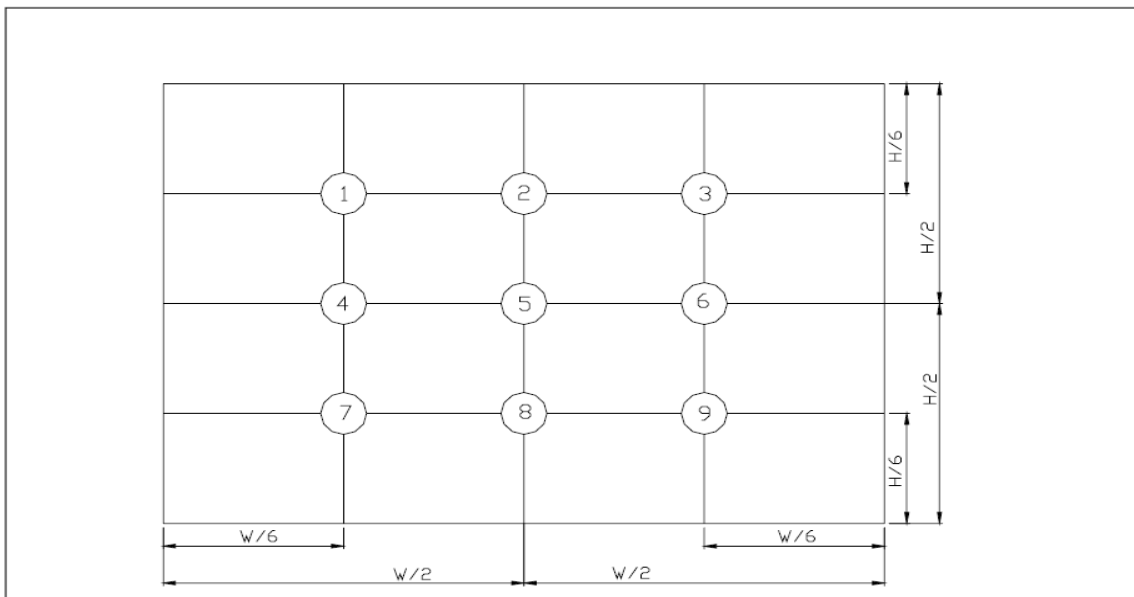

( 單位 : mm )

**13. Reliability Test**

No.	Test Items	Test Condition	Remark
1	High Temperature Storage Test	T <sub>a</sub> = 80°C 240 hours	(1),(3),(4)
2	Low Temperature Storage Test	T <sub>a</sub> = -30°C 240 hours	(1),(3),(4)
3	High Temperature Operation Test	T <sub>s</sub> = 70°C 240 hours	(2),(3),(4)
4	Low Temperature Operation Test	T <sub>a</sub> = -20°C 240 hours	(1),(3),(4)
5	High Temperature and High Humidity Operation Test	T <sub>a</sub> =60°C 90%RH 240 hours	(3), ( 4 )
6	Electro Static Discharge Test ( non-operating )	-Panel Surface/Top Case : 150pF, 330Ω Air : ±15kV, Contact: ±8kV	( 3 )
7	Mechanical Shock Test ( non-operating )	Half sine wave, 100G, 6ms 3 times shock of each six surfaces	( 3 )
8	Vibration Test ( non-operating )	Sine wave, 10 ~ 55 ~ 10Hz, 3 axis, 2 hours/axis	( 3 )
9	Thermal Shock Test ( non-operating )	-20°C ( 30min ) ~ 70°C ( 30min ) ,10 cycles	( 3 ) , ( 4 )
10	Drop Test(with Carton)	Height : 80cm 1 corner, 3 edges, 6 surfaces	( 3 )

Note 1 : T<sub>a</sub> is the ambient temperature of samples.

Note 2 : T<sub>s</sub> is the temperature of panel's surface.

Note 3 : In the standard condition, there shall be no practical problem that may affect the display function.

After the reliability test, the product only guarantees operation, but don't guarantee all of the cosmetic specification.

Note 4 : Before cosmetic and function test, the product must have enough recovery time, at least 2 hours at room temperature.



### 14. Packaging

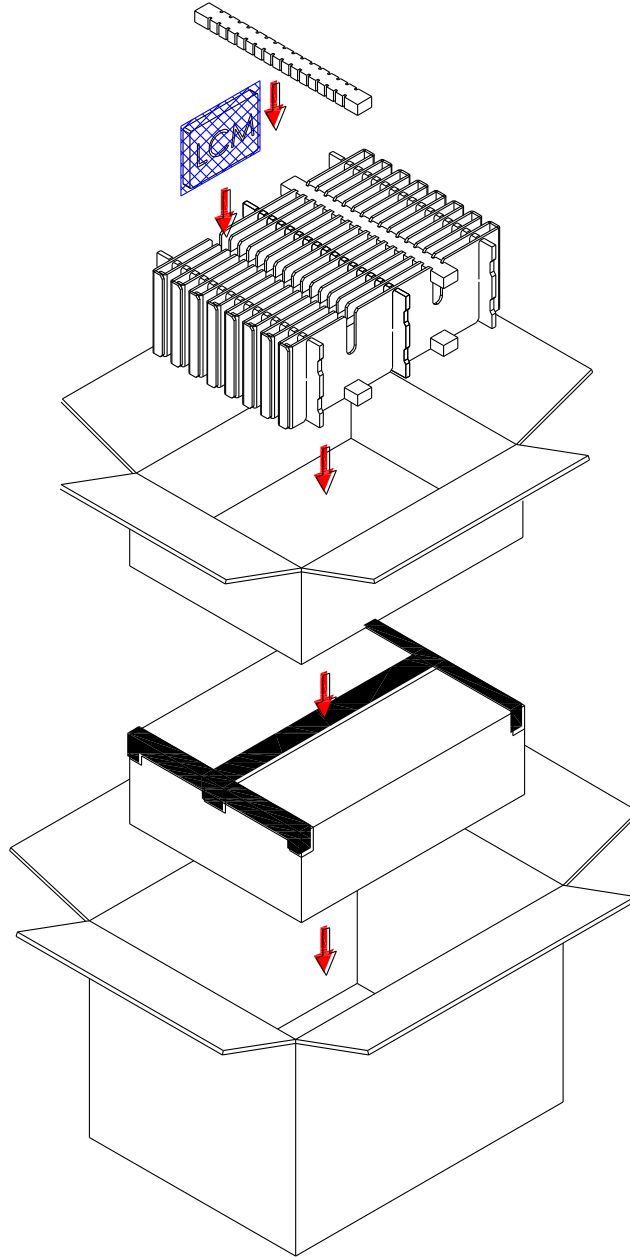

PARTS LIST					
	ITEM	SIZE(LxWxH) unit:mm	MATERIAL	Q.T.Y	NOTE
1	STATIC SHIEDING BAGS	300.0x145.0x0.09		60	
2	EPE PAD	345.0x30.0x20.0	EPE	8	
3	CARD BOARD	345.0x150.0x3.5	CARTON	6	
4	CARD BOARD	450.0x23.0x150.0	CARTON	16	
5	INTERNAL BOX	455.0x350.0x164.0	CARTON	2	
6	EXTERNAL BOX	475.0x370.0x375.0	CARTON	1	
7	PRODUCT	166.6x109.4x11.15		60	



## 15. Precautions

### 15.1 Assembly and Handling Precautions

- (1) Do not apply rough force such as bending or twisting to the module during assembly.
- (2) It's recommended to assemble or to install a module into the user's system in clean working areas. The dust and oil may cause electrical short or worsen the polarizer.
- (3) Don't apply pressure or impulse to the module to prevent the damage of LCD panel and Backlight.
- (4) Always follow the correct power-on sequence when the LCD module is turned on. This can prevent the damage and latch-up of the CMOS LSI chips.
- (5) Do not plug in or pull out the I/F connector while the module is in operation.
- (6) Do not disassemble the module.
- (7) Use a soft dry cloth without chemicals for cleaning, because the surface of polarizer is very soft and easily scratched.
- (8) Moisture can easily penetrate into LCD module and may cause the damage during operation.
- (9) High temperature or humidity may deteriorate the performance of LCD module. Please store LCD module in the specified storage conditions.
- (10) When ambient temperature is lower than 10°C, the display quality might be reduced. For example, the response time will become slow.

### 15.2 Safety Precautions

- (1) If the liquid crystal material leaks from the panel, it should be kept away from the eyes or mouth. In case of contact with hands, skin or clothes, it has to be washed away thoroughly with soap.
- (2) After the module's end of life, it is not harmful in case of normal operation and storage.

### 15.3 Terms of Warrant

- (1) Acceptance inspection period  
The period is within one month after the arrival of contracted commodity at the buyer's factory site.
- (2) Applicable warrant period  
The period is within twelve months since the date of shipping out under normal using and storage conditions.



**P-TEC**

**MODEL NO.**

**PAGE**

PT804870G-TLMWD-EMC22

SPEC SAMPLE

30

### **15.4 Caution**

This P-tec LCD module has been specifically designed for use only in electronic devices in the areas of audio control, office automation, industrial control, home appliances, etc. The modules should not be used in applications where module failure could result in physical harm or loss of life, and P-tec expressly disclaims any and all liability relating in any way to the use of the module in such applications.



### 16.Outline Drawing

NOTE : Unspecified Tolerance : ±0.5

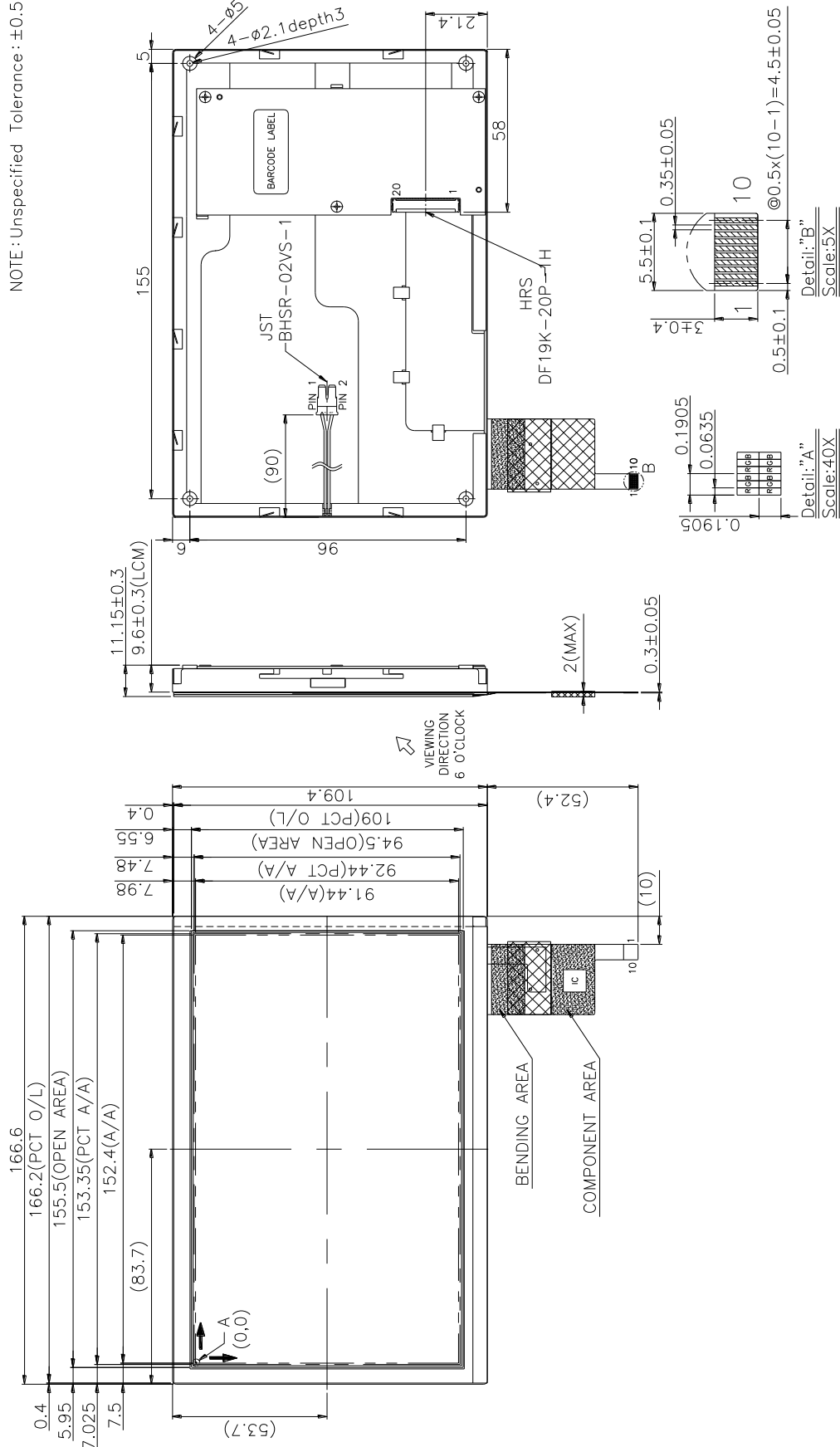



### 17. Definition of Labels

The bar code nameplate is pasted on each module as illustration, and its definitions are as following explanation.



(a) Module Name : PT804870G-TLMWD-EMC22

(b) Serial ID :

A B C D    E F G    H    I J K L

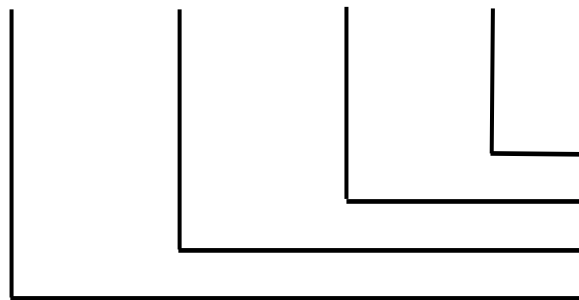

Serial No.  
 Factory Code  
 Manufactured Date  
 Screen Size

Serial ID includes the information as below:

(a) Screen size (Diagonal): Inch Code (ABCD)

3.5" → 0350

10.4" → 1040

(b) Manufactured Date: Year, Month, Day (EFG)

Year (E)

Year	2000	2001	2002	2003	2004	2005	2006	2007	2008	2009
Mark	0	1	2	3	4	5	6	7	8	9
Year	2010	2011	2012	2013	2014	2015	2016	2017	2018	2019
Mark	A	B	C	D	E	F	G	H	I	J





Month (F)

Month	Jan.	Feb.	Mar.	Apr.	May	Jun.	Jul.	Aug.	Sep.	Oct.	Nov.	Dec.
Mark	1	2	3	4	5	6	7	8	9	A	B	C

Day (G)

Day	1	2	3	4	5	6	7	8	9	10	11	12	13	14	15	16
Mark	1	2	3	4	5	6	7	8	9	A	B	C	D	E	F	G
Day	17	18	19	20	21	22	23	24	25	26	27	28	29	30	31	
Mark	H	I	J	K	L	M	N	O	P	Q	R	S	T	U	V	

(c) Factory Code (H):

For P-TEC internal use.

(d) Serial No. (IJKL):

Manufacturing sequence of product, for example: 0001~9999.



## 18. Incoming Inspection Standards

### 18.1 The environmental condition of inspection

The environmental condition and visual inspection shall be conducted as below.

- (1) Ambient temperature  $25 \pm 5^{\circ}\text{C}$
- (2) Humidity: 45 ~ 65 % RH
- (3) Viewing distance is approximately 30 ~ 40 cm
- (4) Viewing angle is normal to the LCD panel as Fig \_1 (  $\pm 45^{\circ}$  )
- (5) Ambient Illumination: 300 ~ 500 Lux for external appearance inspection

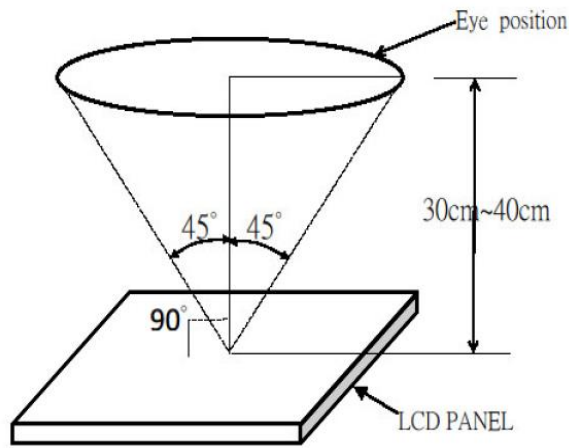

Fig\_1

### 18.2 The defects classify of AQL as following:

- (1) Test method :According to ANSI/ASQC Z 1.4 .General Inspection Level II take a single time
- (2) The defects classify of AQL as following:

Class of defects	AQL	Definition
Major	0.65%	It is defect that is likely to result in failure or to reduce materially the usability of the intended function.
Minor	1.5%	It is a defect that will not result in functioning problem with deviation classified.



### 18.3 Inspection Parameters

Item		Specification/Description			Note	
Display	Function	No Display			-	
		Malfunction			-	
Operating	Contrast ratio	Out of Spec			-	
	Line defect	No obvious Vertical and Horizontal line defect in bright , dark and colored.			-	
	Point Defect (red ,green ,blue ,dark ,white)	Item	Acceptable number			Note: 1、4、 5、6
			A	B	Total	
		BRIGHT DOT	$N \leq 3$	$N \leq 3$	$N \leq 8$	
		DARK DOT	$N \leq 5$	$N \leq 6$		
		TOTAL DOT	$N \leq 5$	$N \leq 6$		
		TWO ADJACENT DOT	NOT ALLOWED			
THREE OR MORE ADJACENT DOT	NOT ALLOWED					
External Inspection (non-operating or operating)	Scratch (in display area)	L(mm)	W(mm)	Acceptable number	Note:2	
		$L \leq 2.5$	$W \leq 0.1$	4		
		$L > 2.5$	$W > 0.1$	0		
	Polarizer dent or bubble (in display area)	Dimension(mm)		Acceptable number	Note:3	
		$D \leq 0.25$		Disregard		
		$D \leq 0.5$		4		
	Line Shape (Particles and Lint in display area)	L(mm)	W(mm)	Acceptable number	Note:2	
		-	$W \leq 0.07$	Disregard		
		$L \leq 5$	$W \leq 0.1$	4		
		$L \geq 5$	$W \geq 0.1$	0		
	Dot Shape (Particle in Display area)	Dimension(mm)		Acceptable number	Note:3	
		$D \leq 0.25$		Disregard		
		$D \leq 0.5$		4		

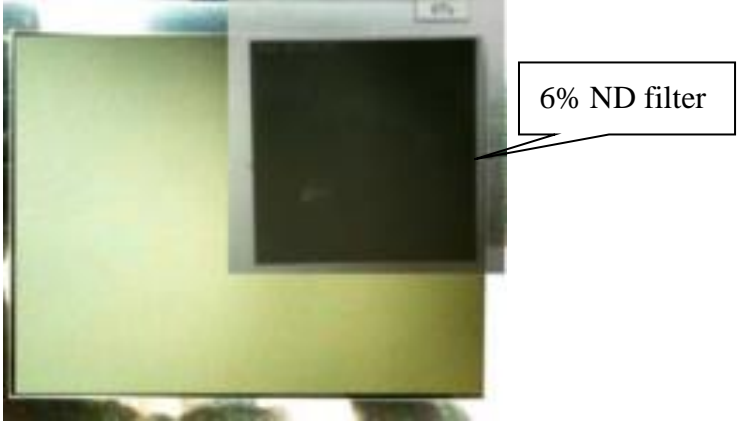

Item	Specification/Description	Note
<p>External Inspection (non-operating or operating)</p>	<p>Has the non-uniform phenomenon</p> 	
	<p>mura</p> <p>Weak defect will be defined as mura if it can be observed through ND filter 6%</p> 	

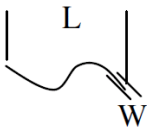
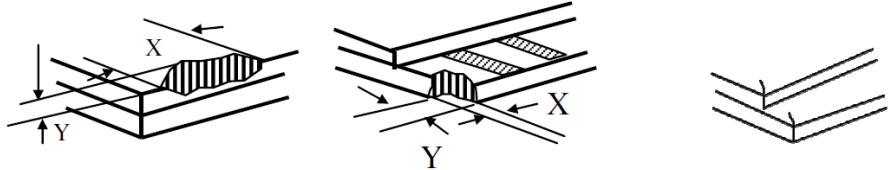

**Incoming Inspection Touch Panel**

<p>Circular Defects</p> <p>Linear Defects</p> <p>Scratch</p> <p>Air Bubble</p> <p>Crack</p> <p>Y: Long breakage</p> <p>Z: Wide breakage</p> <p>D: thickness breakage</p> <p>T: single piece of glass thickness (Touch sensor single thickness)</p> <p>VA: Touch control panel viewing area.</p> <p>Sensor wide: the size of the long side of the touch panel.</p>	<p>(1) Circular Defects</p> $\phi = (L+W)/2$ <table border="1"> <thead> <tr> <th>Diameter(mm)</th> <th>Spec</th> </tr> </thead> <tbody> <tr> <td><math>\phi \leq 0.25</math></td> <td>No quantity limit</td> </tr> <tr> <td><math>0.25 &lt; \phi \leq 0.5</math></td> <td>Max 5 defect</td> </tr> <tr> <td><math>0.5 &lt; \phi</math></td> <td>Reject</td> </tr> </tbody> </table>	Diameter(mm)	Spec	$\phi \leq 0.25$	No quantity limit	$0.25 < \phi \leq 0.5$	Max 5 defect	$0.5 < \phi$	Reject				
	Diameter(mm)	Spec											
	$\phi \leq 0.25$	No quantity limit											
	$0.25 < \phi \leq 0.5$	Max 5 defect											
	$0.5 < \phi$	Reject											
	<p>(2) Linear Defects</p>  <table border="1"> <thead> <tr> <th>Length</th> <th>Width</th> <th>Acceptable</th> </tr> </thead> <tbody> <tr> <td><math>12.0 \geq L</math></td> <td><math>0.06 \geq W</math></td> <td>Accept</td> </tr> <tr> <td><math>12.0 \geq L</math></td> <td><math>0.08 \geq W</math></td> <td>Max 5 defect</td> </tr> <tr> <td><math>L &gt; 12.0</math></td> <td><math>W &gt; 0.08</math></td> <td>Reject</td> </tr> </tbody> </table> <p>The Min distance of defects must be above 15.0mm.</p>	Length	Width	Acceptable	$12.0 \geq L$	$0.06 \geq W$	Accept	$12.0 \geq L$	$0.08 \geq W$	Max 5 defect	$L > 12.0$	$W > 0.08$	Reject
	Length	Width	Acceptable										
	$12.0 \geq L$	$0.06 \geq W$	Accept										
	$12.0 \geq L$	$0.08 \geq W$	Max 5 defect										
	$L > 12.0$	$W > 0.08$	Reject										
<p>(3) Scratch</p> <table border="1"> <thead> <tr> <th>Length</th> <th>Width</th> <th>Acceptable</th> </tr> </thead> <tbody> <tr> <td><math>12.0 \geq L</math></td> <td><math>0.06 \geq W</math></td> <td>Accept</td> </tr> <tr> <td><math>12.0 \geq L</math></td> <td><math>0.08 \geq W</math></td> <td>Max 5 defect</td> </tr> <tr> <td><math>L &gt; 12.0</math></td> <td><math>W &gt; 0.08</math></td> <td>Reject</td> </tr> </tbody> </table> <p>The Min distance of defects must be above 15.0mm.</p>	Length	Width	Acceptable	$12.0 \geq L$	$0.06 \geq W$	Accept	$12.0 \geq L$	$0.08 \geq W$	Max 5 defect	$L > 12.0$	$W > 0.08$	Reject	
Length	Width	Acceptable											
$12.0 \geq L$	$0.06 \geq W$	Accept											
$12.0 \geq L$	$0.08 \geq W$	Max 5 defect											
$L > 12.0$	$W > 0.08$	Reject											
<p>(4) Air Bubble</p> <table border="1"> <thead> <tr> <th>Diameter(mm)</th> <th>Spec</th> </tr> </thead> <tbody> <tr> <td><math>\phi \leq 0.2</math></td> <td>No quantity limit</td> </tr> <tr> <td><math>0.2 &lt; \phi \leq 0.6</math></td> <td>Max 5 defect</td> </tr> </tbody> </table> <p>The Min distance of defects must be above 10.0mm.</p>	Diameter(mm)	Spec	$\phi \leq 0.2$	No quantity limit	$0.2 < \phi \leq 0.6$	Max 5 defect							
Diameter(mm)	Spec												
$\phi \leq 0.2$	No quantity limit												
$0.2 < \phi \leq 0.6$	Max 5 defect												
<p>(5) Crack</p>  <p><math>Z \leq T, X \leq 1/8</math> Sensor wide</p> <p><math>X \leq 3\text{mm}</math> and <math>Y \leq 1/3D</math></p> <p>Y: Did not enter the VA</p> <p>(Accept) (Accept) (Reject)</p>													



Note1. The definition of dot defect :

The dot defect was judged after repair and the size of a defective dot over 1/2 of whole dot is regarded as one defective dot.

Note2.

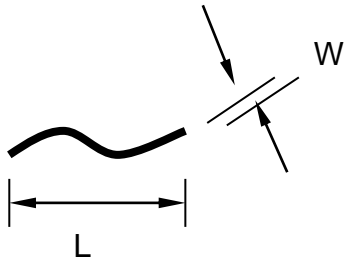

Note3. D : Diameter  $D=(a+b)/2$

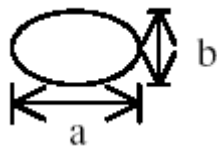

Note4. Bright dot is defined through 2% transmission ND Filter as following.

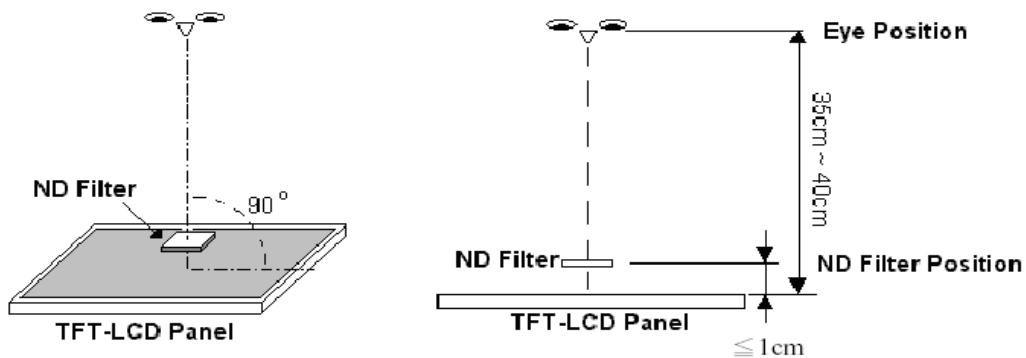

Note5. ADJACENT DOT





Note6.

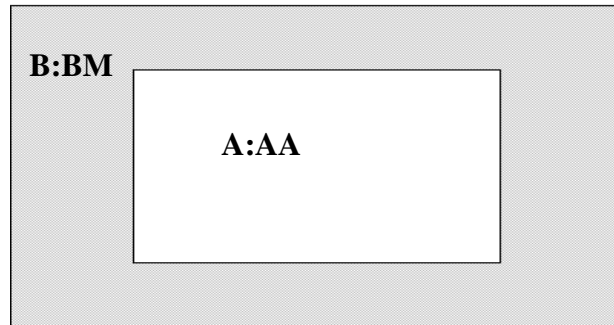

### 18.4 Handling of LCM

- (1) Don't give external shock.
- (2) Don't apply excessive force on the surface.
- (3) Liquid in LCD is hazardous substance. Must not lick and swallow. when the liquid is attach to your hand, skin, cloth etc. Wash it out thoroughly and immediately.
- (4) Don't operate it above the absolute maximum rating.
- (5) Don't disassemble the LCM.