

Hercules Encoders

Smart Encoder Series SE25

- Combined Heavy Duty Encoder and Motor Control Features
- Automatically adjusts to maintain speed with changes in motor load
- Enclosure: SE25-2.5" Dia.
NEMA 6P and IEC IP 67 type sealing
Servo, Flush or Flanged Mounting
- Shielded ABEC 5 Stainless Steel Spindle Bearings, Standard and Self-Mounting options
- Operating Voltage Flexibility – 8 to 28 Vdc or 5 Vdc TTL Output, 5V or 8-15V with Line Driver
- Operating Temperature Rating designed for extremes, from -40° to +85°C (-40° to +185°F)



Specifications

Mechanical

Shaft Speed	6000 RPM maximum
Shaft Direction	Bidirectional
Standard Shaft Sizes	.3747", .4997"
Shaft Extension(s)	Std 0.875", .50 x .05" flat
Shaft Seals	Neoprene or PTFE Options
Mounting	Refer to dimensional drawings
Bearings	.5000" ID ABEC 5 Spindle
Radial Loading	90 lbs. Operating
Axial Loading	45 lbs. Operating
Accuracy	±0.1° of Shaft Rotation Typ.
Housing	Black Anodized Aluminum
Weight	22 oz.
Connector	6, 7, 10 Pin MS3102 or 18" Cable Out

Electrical

Supply Voltage	8 to 28 Vdc 5 Vdc TTL output
Supply Current	100 mA typical., 120 mA maximum
Current Sinking	250 mA max
Connections	Configured to Customer Requirement

Environmental

Operating Temperature	-40° to +85°C (-40° to +185°F)
Shock	50 g's for 11 Milliseconds
Vibration	5 to 2000 Hertz at 20 g's
Humidity	100% Relative Humidity
Enclosures (Sealed)	NEMA 6P, IEC IP 67 – Water-tight

for the latest specifications visit our website
www.herculesencoders.com

Rev. A

Dimensional Drawings

Smart Encoder Series SE25

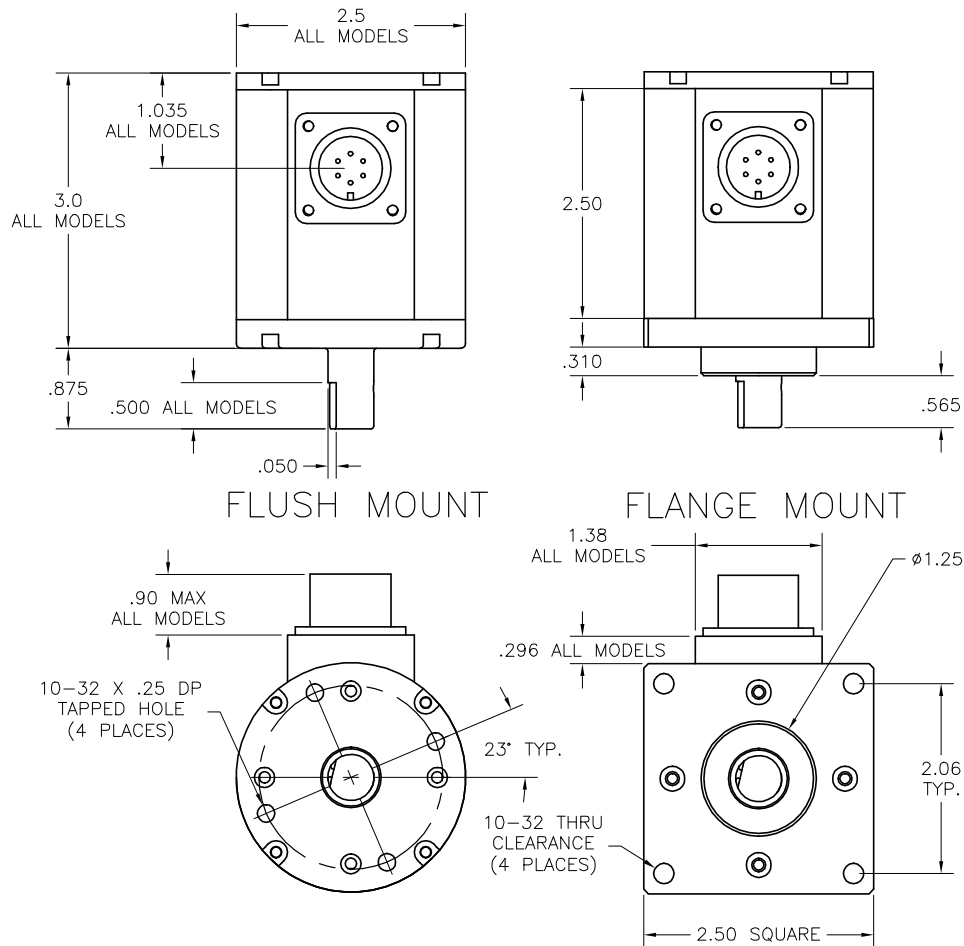

Creating a Part Number

SE25 - 1 1 2 - X - XX

Size	Mounting Style	Shaft Style	Connector Style	Output Communication Protocol	Variations
SE25	1=Flush mount 3=Flange mount	1=3/8" Standard Shaft 2=1/2" Standard Shaft	1=6 Pin rear mounted 2=6 Pin side mounted 3=7 Pin rear mounted 4=7 Pin side mounted 5=10 Pin rear mounted 6=10 Pin side mounted 7=Cable rear mounted 8=Cable side mounted	0=None 1=RS232 2=CANBUS	User defined functions Contact factory