



The Future of Analog IC Technology®

EV4601ES-00A

Buck-Boost White LED Driver For TV Backlighting Applications

DESCRIPTION

The EV4601ES-00A Evaluation Board is designed to demonstrate the capabilities of MPS' MP4601ES for TV backlighting applications. MP4601 is an integrated Buck-Boost white LED driver which is suitable for TV and big panel backlighting applications with MPS patented pending technology.

With a 12V input V_{IN} and a high voltage source V_{INH} , EV4601ES-00A can deliver a regulated voltage (V_{INH} to $V_{INH}+60V$) to drive a LED string over 350V. The LED current is regulated to about 120mA. The EV4601ES-00A can be synchronized. Several EV4601ES-00As can be used together to drive a TV panel

ELECTRICAL SPECIFICATION

Parameter	Symbol	Value	Units
Input Voltage	V_{IN}	12±10%	V
Enable	EN	5±10%	V
Dimming	DIM	5±10%	V
LED Current	I_{LED}	120±5%	mA
Switching Frequency	f_s	300	kHz
Over Voltage Protection	$V_{LED-Max}$	-63	V

FEATURES

- Novel Power Leverage Control Technology
- Negative Output Buck-Boost Operation
- Switching Frequency Synchronization
- Analog and PWM Dimming Control
- Programmable Cycle-by-Cycle Over Current Protection
- Thermal Shutdown Protection
- LED Short and Open Protection
- Fault Output for Short LED Protection
- Output Short Circuit Protection

APPLICATIONS

- TV Backlighting
- Large LCD Panels Backlighting

For MPS green status, please visit MPS website under Quality Assurance. "MPS" and "The Future of Analog IC Technology", are Registered Trademarks of Monolithic Power Systems, Inc.

EV4601ES-00A EVALUATION BOARD



(L x W x H) 5cm x 4.6cm x 4.5mm

Board Number	MPS IC Number
EV4601ES-00A	MP4601ES

Efficiency vs. V_{INH}

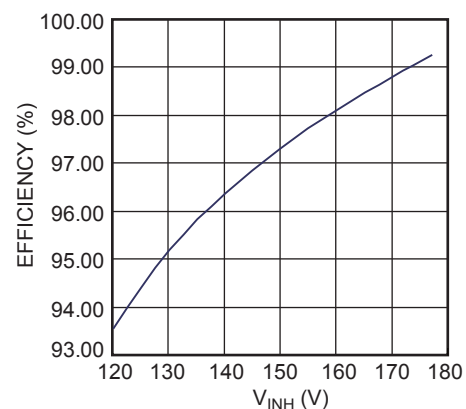

EVALUATION BOARD SCHEMATIC

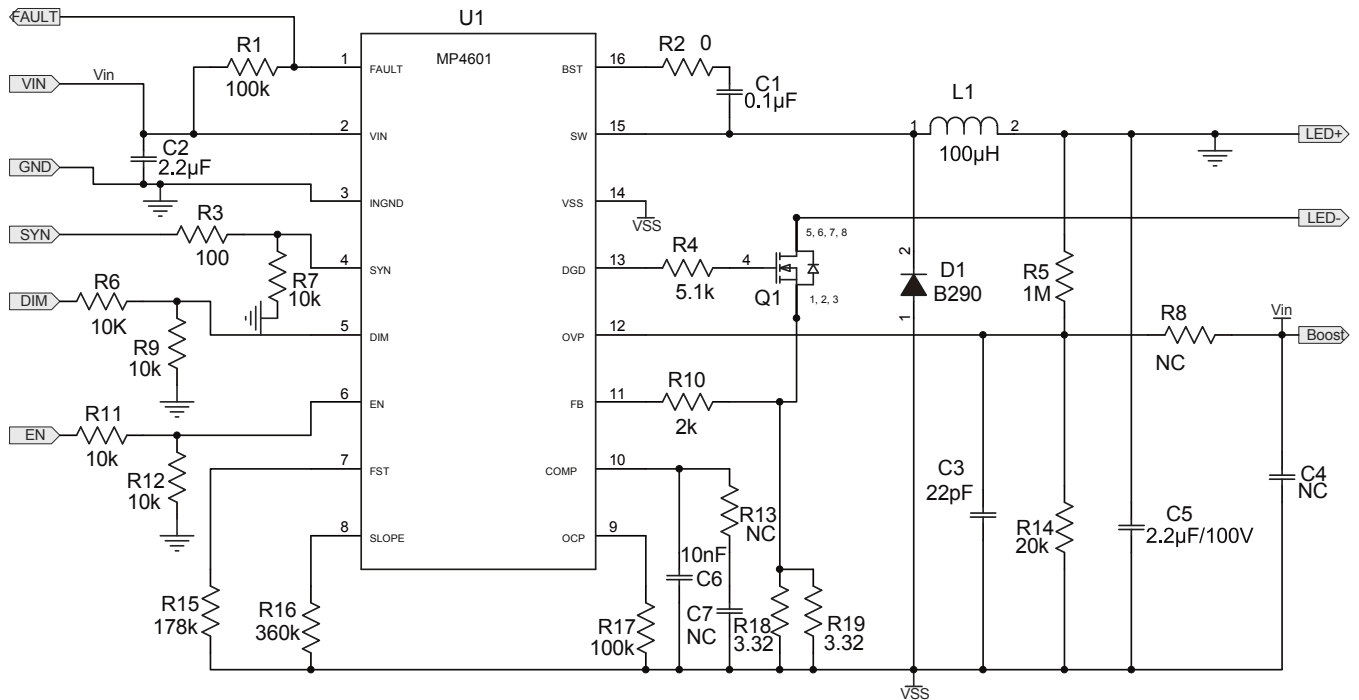

EV4601ES-00A BILL OF MATERIALS

Qty	Ref	Value	Description	Package	Manufacturer	Part Number
1	C1	0.1µF	Ceramic Capacitor;50V;X7R;0603	0603	muRata	GRM188R71H104KA93D
1	C2	2.2µF	Ceramic Capacitor;100V;X7R;1210	1210	muRata	GRM32ER72A225KA35L
1	C3	22pF	Ceramic Capacitor;50V;NPO;0603	0603	LION	0603N220J500T
1	C4	NC				
1	C5	2.2µF/100V	Ceramic Capacitor;100V;X7R;1210	1210	muRata	GRM32ER72A225KA35L
1	C6	10nF	Ceramic Capacitor;50V;X7R;0603	0603	muRata	GRM188R71H103KA01D
1	C7	NC	Ceramic Capacitor;25V;C0G;0603	0603	muRata	
1	D1	B290	Schottky Diode;90V;2A	SMB	Diodes	B290-F
1	L1	100µH	Inductor;100uH;255mOhm;1.2A	SMD	Würth	744066101
1	Q1	SMK0260D	N-Channel Mosfet;600V, 2A	DPAK (TO-252)	AUK	SMK0260D

EV4601ES-00A BILL OF MATERIALS (continued)

Qty	Ref	Value	Description	Package	Manufacturer	Part Number
2	R1,R17	100k	Film Resistor;1%	0603	Yageo	RC0603FR-07100KL
1	R2	0	Film Resistor;5%	0603	Yageo	RC0603JR-070RL
1	R3	100	Film Resistor;1%	0603	Yageo	RC0603FR-07100RL
1	R4	5.1k	Film Resistor;1%	0603	Yageo	RC0603FR-075K1L
1	R5	1M	Film Resistor;1%	0603	Yageo	RC0603FR-071ML
5	R6, R7, R9, R11, R12	10k	Film Resistor;1%	0603	Yageo	RC0603FR-0710KL
2	R8, R13	NC				
1	R10	2k	Film Resistor;1%	0603	Yageo	RC0603FR-072KL
1	R14	20k	Film Resistor;1%	0603	Yageo	RC0603FR-0720KL
1	R15	178k	Film Resistor;1%	0603	Yageo	RC0603FR-07178KL
1	R16	360k	Film Resistor;1%	0603	Yageo	RC0603FR-07360KL
2	R18, R19	3.32	Film Resistor;1%	0603	Yageo	RC0603FR-073R32L
1	U1	MP4601ES	MP4601ES	SOIC16	MPS	

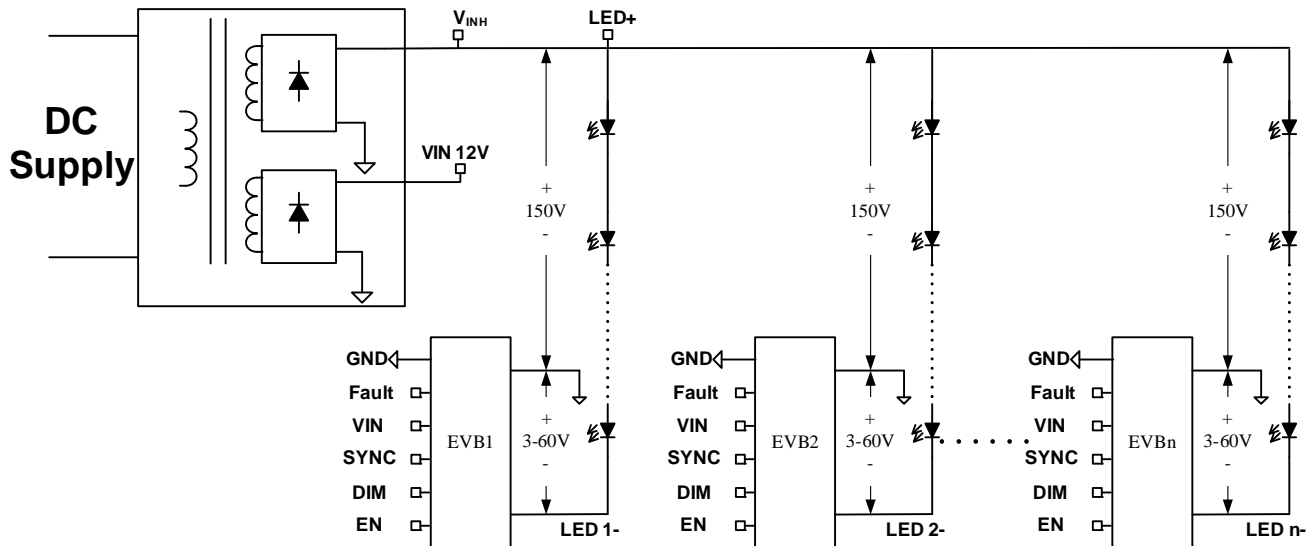
EXAMPLE OF TV BACKLIGHT DRIVE WITH SEVERAL EV4601ES-00A

EVB TEST RESULTS

Performance waveforms are tested on the evaluation board.

VIN = 12V, VINH=150V, VLED=180V, ILED = 120mA, TA = 20°C, unless otherwise noted.

PWM Dimming Curve

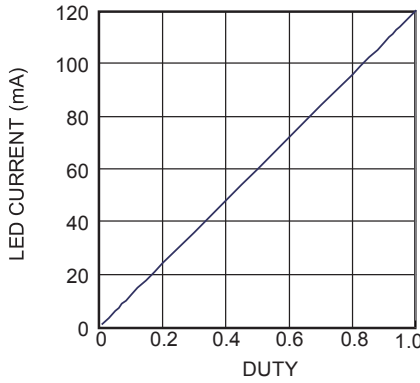

Analog Dimming Curve

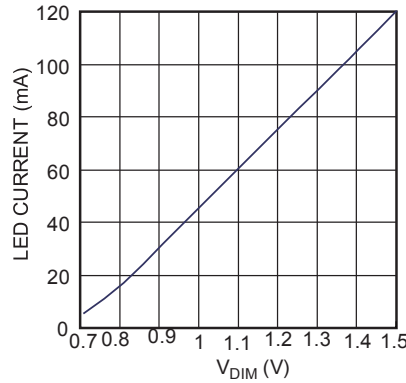

Steady State

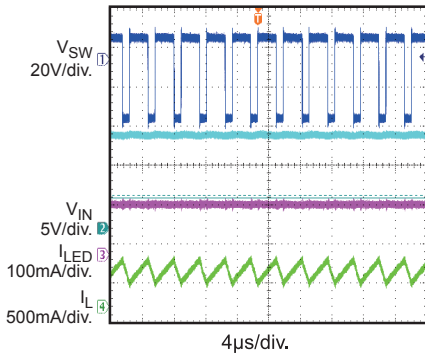

VIN Start

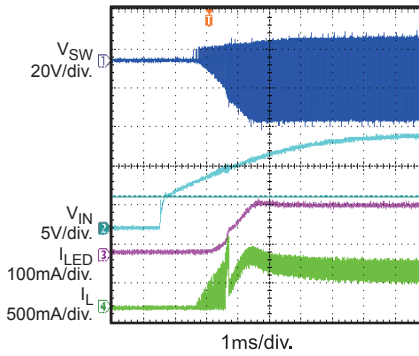

EN Start

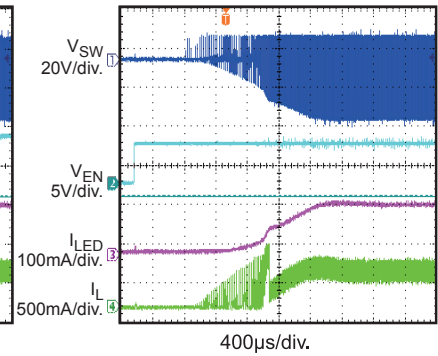

PWM Dimming

f_{PWM} = 200Hz, DUTY = 50%

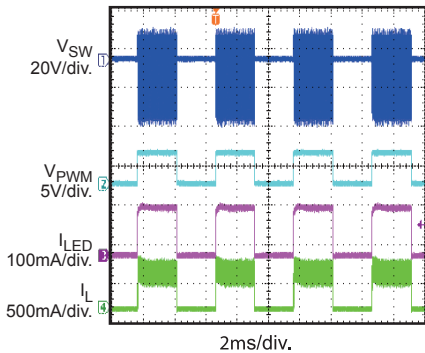

OVP@Working

OVP Point = 63V

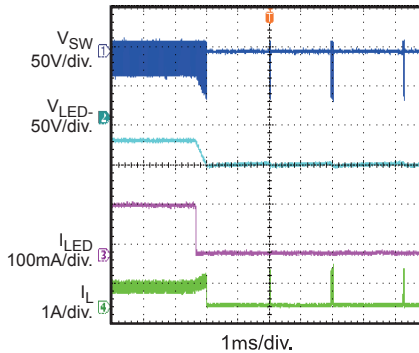

Short LED- to GND@Working

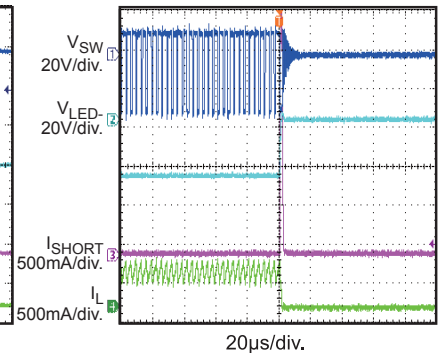

PRINTED CIRCUIT BOARD LAYOUT

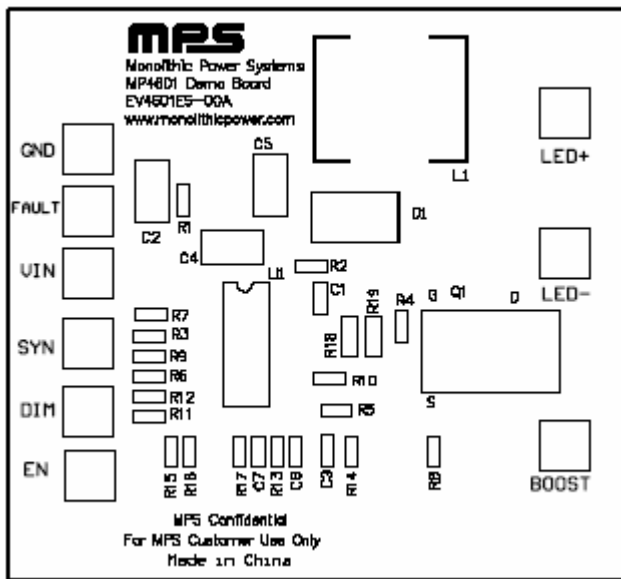

Figure 1—Top Silk Layer

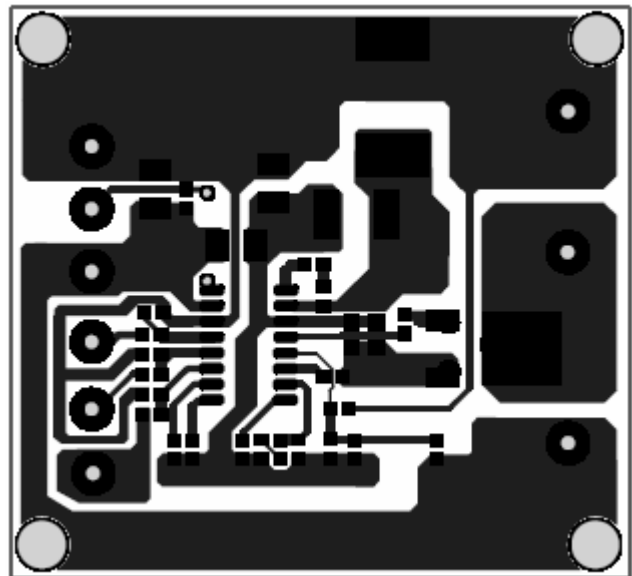

Figure 2—Top Layer

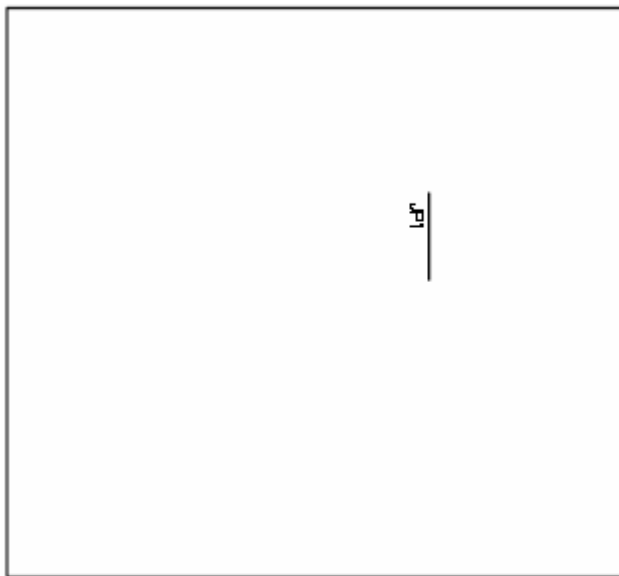

Figure 3—Bottom Silk Layer

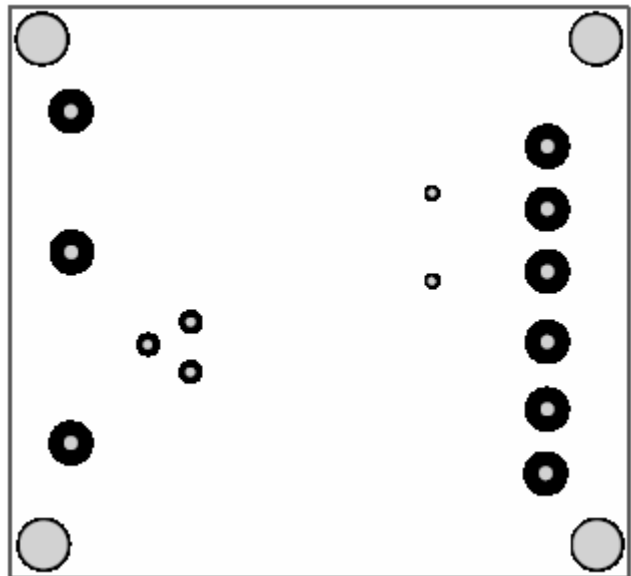

Figure 4—Bottom Layer

QUICK START GUIDE

1. Check the LED string voltage and preset the high voltage power supply's output. For example, 60 LED string needs 180V. Set the high voltage power supply output V_{INH} as 150V.
2. Set a second power supply VIN to 12V as the input of all the EVBs. Set a third power supply to 5V as the EN input to all the EVBs, Set a fourth power supply to 5V as the DIM input of all EVBs.
3. Turn-off all power supplies.
4. Connect the positive terminal of the high voltage power supply to all the anodes of the LED strings, and the negative terminal to all the EVB GND connector.
5. Connect each LED string cathode to the LED- connector on one EVB individually (one EVB for one LED string).
6. Connect VIN (12V) the positive terminal to all the EVB VIN connectors and the negative terminal to all the EVB GND connectors.
7. Connect the 5V DIM power supply positive terminal to all the EVB DIM connectors, and negative terminal to all the EVB GND connectors.
8. Connect the 5V EN power supply positive terminal to all the EVB EN connectors, and negative terminal to all the EVB GND connectors.
9. Connect all SYNC pin of all EVBs together for synchronization if necessary.
10. Turn on the high voltage power supply.
11. Turn on the 12V power supply.
12. Turn on the 5V DIM power supply.
13. Turn on the 5V EN power supply. All the LED strings should be lighted.
14. To demo the dimming function: replace the 5V power supply with a function generator. Set the PWM signal amplitude to 5V and the frequency within 100Hz to 20kHz range. For analog dimming, adjust the power supply on DIM connector from 1.4V to 3V

NOTICE: The information in this document is subject to change without notice. Please contact MPS for current specifications. Users should warrant and guarantee that third party Intellectual Property rights are not infringed upon when integrating MPS products into any application. MPS will not assume any legal responsibility for any said applications.