

PLEASE CHECK WWW.MOLEX.COM FOR LATEST PART INFORMATION

Part Number: [0026481022](#)
Status: **Active**
Description: 3.96mm (.156") Pitch KK® Header, Breakaway, Right Angle, 2 Circuits, Tin (Sn) Plating

Documents:

[3D Model](#)
[Packaging Specification \(PDF\)](#)
[Drawing \(PDF\)](#)
[Product Specification PS-08-50 \(PDF\)](#)
[RoHS Certificate of Compliance \(PDF\)](#)

Agency Certification

CSA LR19980
 UL E29179

General

Product Family PCB Headers
 Series [41662](#)
 Application Board-to-Board, Wire-to-Board
 MolexKits Yes
 Product Name KK®

Physical

Breakaway Yes
 Circuits (Loaded) 2
 Circuits (maximum) 2
 Color - Resin Black
 Durability (mating cycles max) 25
 First Mate / Last Break No
 Flammability 94V-0
 Glow-Wire Compliant No
 Guide to Mating Part No
 Keying to Mating Part None
 Lock to Mating Part None
 Material - Metal Brass
 Material - Plating Mating Tin
 Material - Plating Termination Tin
 Material - Resin Polyester
 Number of Rows 1
 Orientation Right Angle
 PC Tail Length (in) 0.184 In
 PC Tail Length (mm) 4.67 mm
 PCB Locator No
 PCB Retention None
 PCB Thickness Recommended (in) 0.062 In
 PCB Thickness Recommended (mm) 1.60 mm
 Packaging Type Bag
 Pitch - Mating Interface (in) 0.156 In
 Pitch - Mating Interface (mm) 3.96 mm
 Plating min: Mating (µin) 200
 Plating min: Mating (µm) 5
 Plating min: Termination (µin) 200
 Plating min: Termination (µm) 5
 Polarized to Mating Part Yes
 Polarized to PCB No
 Shrouded Partial
 Stackable No
 Temperature Range - Operating 0°C to +75°C

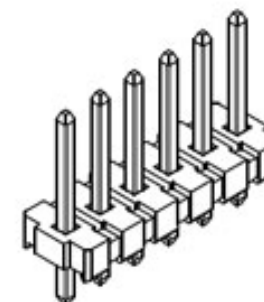

image - Reference only

Series

EU RoHS

ELV and RoHS Compliant
REACH SVHC Contains SVHC: No
Halogen-Free Status

China RoHS



Need more information on product environmental compliance?

Email productcompliance@molex.com
 For a multiple part number RoHS Certificate of Compliance, [click here](#)

Please visit the [Contact Us](#) section for any non-product compliance questions.

Search Parts in this Series

[41662Series](#)

Mates With

[2139](#) , [2145](#) , [6442](#) , [7674](#) , [7675](#) , [41695](#) , [41815](#)

Termination Interface: Style Through Hole

Electrical

Current - Maximum per Contact 7A
Voltage - Maximum 250V

Solder Process Data

Duration at Max. Process Temperature (seconds) 5
Lead-free Process Capability Wave Capable (TH only)
Max. Cycles at Max. Process Temperature 1
Process Temperature max. C 235

Material Info

Old Part Number A-41662-A02A102

Reference - Drawing Numbers

Packaging Specification PK-41662-001
Product Specification PS-08-50
Sales Drawing SD-41662-001

This document was generated on 06/08/2010

PLEASE CHECK WWW.MOLEX.COM FOR LATEST PART INFORMATION

A-41662-* N * * - *

PACKAGING AND OPTIONS

NO. OF CKTS.

PIN DIMENSIONS

PLATING

VOID LOCATIONS:
 BLANK = NO VOIDS
 NO.= CKT NO. VOIDED
 MULT. VOIDS START WITH 51

CENTERLINE OF PIN IN AREA SHOWN NOT TO VARY FROM CENTERLINE OF PIN AT DATUM Z BY MORE THAN 0.20/.008 IN ANY DIRECTION.

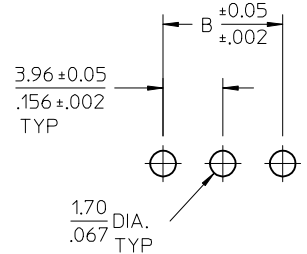
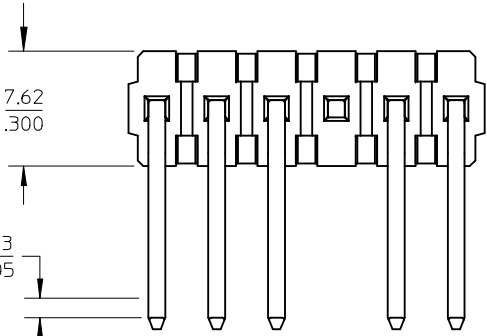

PCB LAYOUT: COMPONENT SIDE
 RECOMMENDED PCB THICKNESS:
 (1.57±.18)/.062±.007

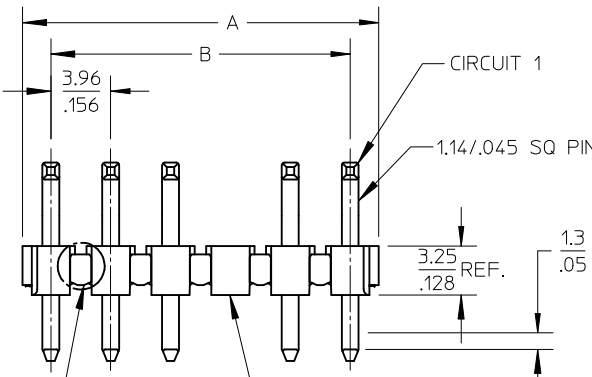
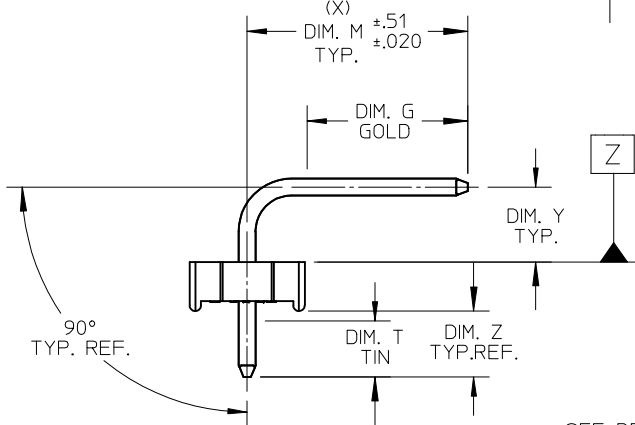

1.3 CENTERLINE OF PIN IN AREA SHOWN NOT TO VARY FROM CENTERLINE OF PIN AT DATUM Z BY MORE THAN 0.13/.005 IN ANY DIRECTION.

SEE DETAIL A

OPTIONAL VOIDED CKT. SEE CHART FOR LOCATIONS

NOTES:

- MATERIAL: GLASS FILLED POLYESTER, 94V-0, MOLDED BLACK
- FINISH: PER SDES-88
 - (102) OVERALL TIN: 0.00508/.000200 MIN.
 - OVERALL COPPER UNDERPLATE: 0.00254/.000100 MIN.
 - (154) OVERALL TIN: 0.00254/.000100 MIN.
 - OVERALL NICKEL UNDERPLATE: 0.00127/.000050 MIN.
 - (208) SELECT GOLD: 0.00038/.000015 MIN.
 - * SELECT TIN: 0.00254/.000100 MIN
 - OVERALL NICKEL UNDERPLATE: 0.00127/.000050 MIN.
 - (228) SELECT GOLD: 0.00076/.000030 MIN.
 - * SELECT TIN: 0.00254/.000100 MIN.
 - OVERALL NICKEL UNDERPLATE: 0.00127/.000050 MIN.
 - (501) OVERALL GOLD: 0.00051/.000020 MIN.
 - OVERALL NICKEL UNDERPLATE: 0.00076/.000030 MIN.

- PRODUCT SPECIFICATION: PS-08-50.
- PACKAGING INFORMATION: SEE CHARTS
- SOLDERABILITY: PER SMES-152.
- PIN PUSH-OUT FORCE: PRIOR TO SOLDERING, A 3 LB. MINIMUM FORCE (IN EITHER DIRECTION) SHALL BE REQUIRED TO PUSH THE PIN OUT OF THE HEADER.
- PARTS ARE STACKABLE END TO END ON 3.96/.156 CENTERS. (SPACING TABS MUST BE REMOVED ON CIRCUIT SIZES 1-23 BEFORE PARTS ARE STACKABLE.)
- THE PRIMARY SHIPPING CARTON WILL BE LABELED, "COMPLIANT TO RoHS DIRECTIVE 2002/95/EC AND ELV ANNEX II OF DIRECTIVE 2000/53/EC". CARTONS WITHOUT THIS LABEL MAY CONTAIN PRODUCT WITH TIN-LEAD PLATING.
- THIS PART CONFORMS TO CLASS B REQUIREMENTS OF COSMETIC SPECIFICATION PS-45499-002.

CIRCUIT	B	A
2	3.96 .156	6.78/7.87 .2677/.310
3	7.92 .312	10.74/11.84 .4231/.466
4	11.89 .468	14.71/15.80 .5791/.622
5	15.85 .624	18.67/19.76 .7351/.778
6	19.81 .780	22.63/23.72 .891/.934
7	23.77 .936	26.59/27.69 1.047/1.090
8	27.74 1.092	30.56/31.65 1.203/1.246
9	31.70 1.248	34.52/35.61 1.359/1.402
10	35.66 1.404	38.48/39.57 1.515/1.558
11	39.62 1.560	42.44/43.54 1.671/1.714
12	43.59 1.716	46.41/47.50 1.827/1.870
13	47.55 1.872	50.37/51.46 1.983/2.026
14	51.51 2.028	54.33/55.42 2.139/2.182
15	55.47 2.184	58.29/59.39 2.295/2.338
16	59.44 2.340	62.26/63.35 2.451/2.494
17	63.40 2.496	66.22/67.31 2.607/2.650
18	67.36 2.652	70.18/71.27 2.763/2.806
19	71.32 2.808	74.14/75.23 2.919/2.962
20	75.29 2.964	78.11/79.20 3.075/3.118
21	79.25 3.120	82.07/83.16 3.231/3.274
22	83.21 3.276	86.03/87.12 3.387/3.430
23	87.17 3.432	89.94/91.08 3.541/3.586
24	91.14 3.588	93.85/95.00 3.695/3.740

2-*	AH7
1	
SHT.	REV.

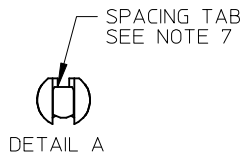

REMOVE 41662-0684 EC NO: UCP2010-0149 DRWN:MKLIPPER 2009/08/05 CHK'D:SSOUSEK 2009/08/10 APPR:FSM TH 2009/08/11	QUALITY SYMBOLS
	DESCRIPTION
AH7	REV

GENERAL TOLERANCES (UNLESS SPECIFIED)	
	mm INCH
4 PLACES	± --- ± ---
3 PLACES	± --- ± .010
2 PLACES	± 0.25 ± .014
1 PLACE	± 0.36 ± ---
ANGULAR ±1/2°	
DRAFT WHERE APPLICABLE MUST REMAIN WITHIN DIMENSIONS	

DIMENSION STYLE	
MM/IN	
DRAWN BY	DATE
JSCHAFFER	2003/09/15
CHECKED BY	DATE
KSAMIEC	2003/09/15
APPROVED BY	DATE
MARGULIS	2003/09/15
MATERIAL NO.	
SEE CHART	
SIZE	
A	

SCALE	DESIGN UNITS	THIRD ANGLE PROJECTION	
4:1	INCH		
TITLE			
KK .156 HEADER ASSEMBLY FLAT BREAKAWAY 2-24 CKTS.			
MOLEX INCORPORATED			
DOCUMENT NO.			SHEET NO.
SD-41662-001			1 OF 12
THIS DRAWING CONTAINS INFORMATION THAT IS PROPRIETARY TO MOLEX INCORPORATED AND SHOULD NOT BE USED WITHOUT WRITTEN PERMISSION			