



## INSTALLATION INSTRUCTIONS

## REPLACEMENT BRUSH KIT

## Part No. 3146A

COMP PUMP® Series 60FI, 110, 110M, 140 and 140M with Internally Serviced Brushes

**Step 1**

Remove the pump from the vehicle and clean pump exterior. Place the pump on its side on a clean work surface. Scribe or draw a line across the pump motor housing, gerotor housing, port plate and fuel chamber so that you can reassemble the pump correctly (See Figure 1).

**Step 2**

Remove the fuel chamber screws from the bottom of the pump, then remove the fuel chamber and port plate from the pump.

**NOTE: Do not drop the gerotor from the gerotor housing cavity (See Figure 2).**

**Step 3**

Place your hand beneath the gerotor and hold the pump in an upright position. The gerotor should slide out of the gerotor housing and into your hand (See Figure 3).

**Step 4**

Remove the motor screws from the top of the pump. Remove the motor from the gerotor housing. (See Figure 4). Push the armature into the motor housing about 1-1/4" and slide the grommet out of its slot. Pull end cap off the commutator (See Figure 5).

**Step 5**

From the center of the end cap, push the brushes back into the brush holders (See Figure 6), until the brush spring fingers are resting against the sides of the brushes (See Figure 7). Pull brushes out of the brush holders. The brush spring fingers will "snap" back into the brush holders. Disconnect the brush leads from the end cap.

**Step 6**

Connect the new brush leads to the end cap. Using a small screwdriver, paper clip, or similar device, pull the brush spring fingers back and insert the new brushes into the brush holders. Release the brush springs. From the center of the end cap, push the new brushes back into the brush holders (See Figure 6) until brush spring fingers are resting against the sides of the brushes (See Figure 7).

**Step 7**

Slide the grommet into its slot. Push the armature into the motor housing about 1" and hold it there. Place the end cap on the commutator. Push the brushes into the brush holders. The brush spring fingers will "snap" into place. Hold the end cap firmly on the commutator. Slowly lower the end cap and commutator into the motor housing until the end cap is fully seated (See Figure 5).

**Step 8**

Place the motor housing on the gerotor housing. Make sure the line across the pump (as described in STEP 1 and Figure 1) align. Install the motor screws and torque to 24 in-lbs.

**Step 9**

Clean the gerotor cavity. Install the gerotor in the gerotor housing. Inspect the o-ring and gasket and replace if necessary. Install the port plate, gasket and fuel chamber with screws.

Make sure the line across the pump (as described in STEP 1 and Figure 1) align. Install the fuel chamber screws and torque to 24 in-lbs.

**Step 10**

Install the pump on the vehicle.

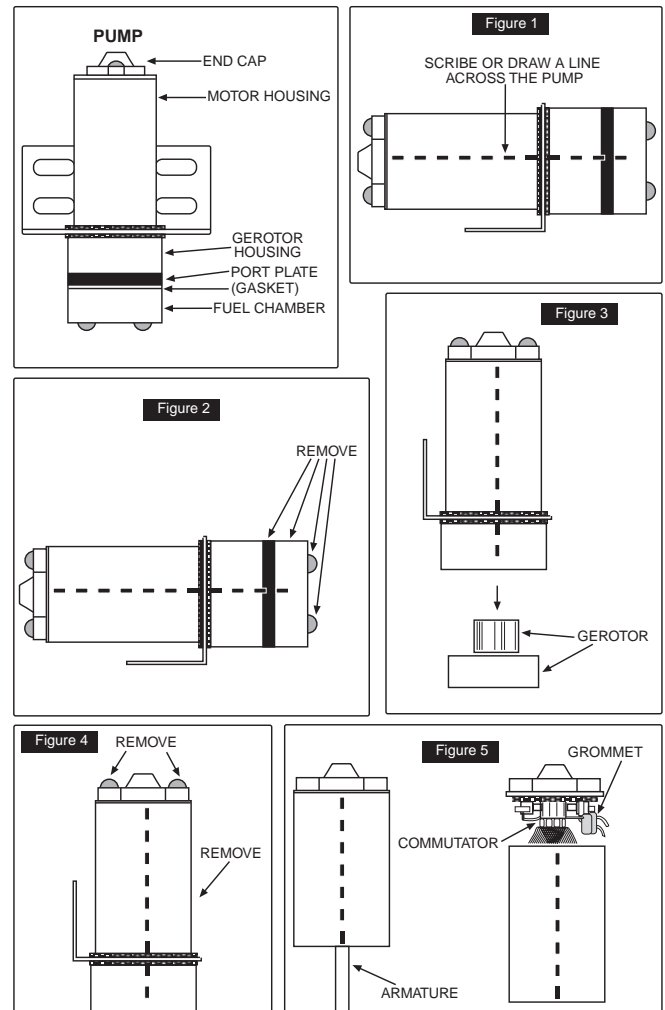

Figure 6

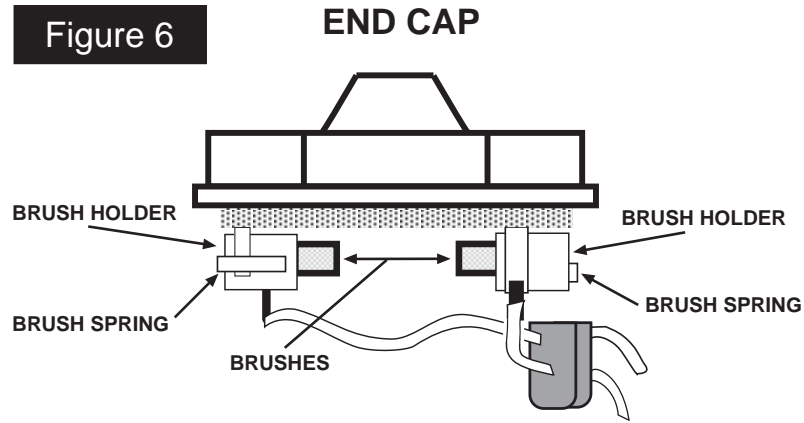
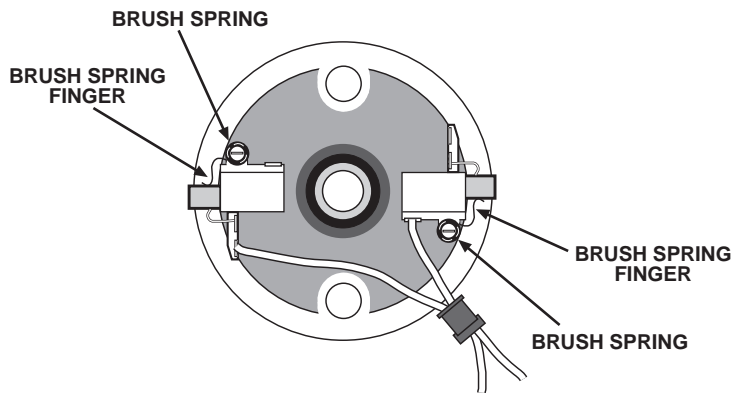

Figure 7



OTHER QUALITY PRODUCTS FROM



- PERFORMANCE FUEL SYSTEM COMPONENTS
- PERFORMANCE IGNITION COILS
- ELECTRONIC IGNITION CONTROL SYSTEMS
- COMPETITION AND PERFORMANCE DISTRIBUTORS
- MAGNETO IGNITION SYSTEMS
- PERFORMANCE TACHOMETERS AND GAUGES
- PERFORMANCE SPARK PLUG WIRE KITS



MALLORY IS A DIVISION OF THE MR. GASKET PERFORMANCE GROUP  
 10601 MEMPHIS AVE. #12, CLEVELAND, OH 44144  
 216.688.8300 FAX 216.688.8306

FORM 1350M  
 (REV. C) 09/03  
 Made in U.S.A.  
 Printed in U.S.A.