

Rev	AWO #	Description	Date	Appr
-		RELEASED	8/3/15	

APPROVED: \_\_\_\_\_  
 DATE: \_\_\_\_\_ TITLE: \_\_\_\_\_

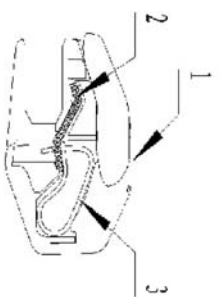
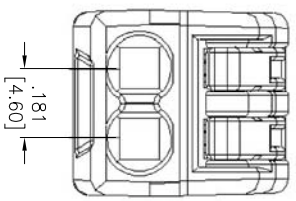
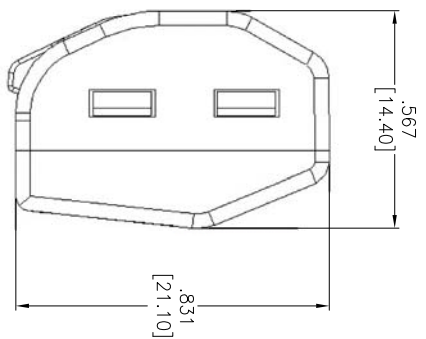
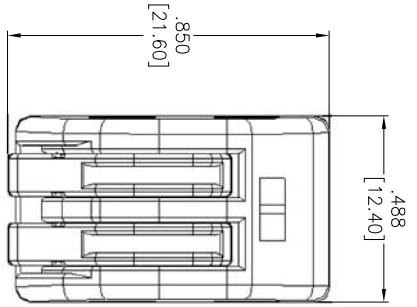

**SPECIFICATION:**

**Material:**  
 Insulator: PA66, Rated UL-94V-0  
 Insulator color: Black  
 Contact: Phosphor Bronze, T=0.8mm, Tin plated  
 Spring: SUS 301, T=0.4mm  
**Electrical:**  
 Operating voltage: 600V  
 Current rating: 24A  
 Contact resistance: 20 mohms max  
 Insulation resistance: 500 Mohms min, DC 500V  
 Dielectric withstanding voltage: 2000VAC/500VDC  
 Wire range: 0.75-2.5mm<sup>2</sup>  
 Maximum tensile strength: 8kg~10kg  
**Temperature Rating:**  
 Operating temperature: -40°C to +105°C  
**Environmental:**  
 Lead free, RoHS compliant.

**ADAM TECH**

909 Rahway Avenue, Union, NJ 07083  
 Phone: 908-687-5000 Fax: 908-687-5710

**SPRING CLAMP BLOCK, 2 POLES**

UNLESS OTHERWISE SPECIFIED ALL DIMENSIONS ARE INCHES [MM]		TITLE	
TOLERANCES: EXCEPT AS NOTED		SPRING CLAMP BLOCK, 2 POLES	
INCHES		REV.	
.X ± .10	ØXX ± .10	-	
.XX ± .020	ØXXX ± .015	-	
.XXX ± .015	ØXXX ± .010	-	
APPROVALS		DATE	
DRAWN	AY	8/3/15	
CHECKED	TW	8/3/15	
APPROVED			
SIZE	PART NO.	REV.	
X	ADT-AN9090-02	-	
REF:	SCALE:	SHEET 1 OF 1	
S00009C	NTS	1	



6 5 4 3 2 1