



Integrated  
Circuit  
Systems, Inc.

**PRELIMINARY**

**ICS844004I**  
FEMTOCLOCKS™ CRYSTAL-TO-  
LVDS FREQUENCY SYNTHESIZER

**GENERAL DESCRIPTION**

The ICS844004I is a 4 output LVDS Synthesizer optimized to generate Fibre Channel reference clock frequencies and is a member of the HiPerClocks™ family of high performance clock solutions from ICS. Using a 26.5625MHz 18pF parallel resonant crystal, the following frequencies can be generated based on the 2 frequency select pins (F\_SEL[1:0]): 212.5MHz, 187.5MHz, 159.375MHz, 156.25MHz, 106.25MHz and 53.125MHz. The ICS844004I uses ICS' 3<sup>rd</sup> generation low phase noise VCO technology and can achieve <1ps typical rms phase jitter, easily meeting Fibre Channel jitter requirements. The ICS844004I is packaged in a small 24-pin TSSOP package.

**FEATURES**

- Four LVDS outputs
- Selectable crystal oscillator interface or LVCMOS/LVTTL single-ended input
- Supports the following output frequencies: 212.5MHz, 187.5MHz, 159.375MHz, 156.25MHz, 106.25MHz, 53.125MHz
- VCO range: 560MHz - 680MHz
- RMS phase jitter @ 212.5MHz, using a 26.5625MHz crystal (637KHz - 10MHz): 0.65ps (typical)
- Full 3.3V or 2.5V supply modes
- -40°C to 85°C ambient operating temperature

**FREQUENCY SELECT FUNCTION TABLE**

Input Frequency (MHz)	Inputs					Output Frequency (MHz)
	F_SEL1	F_SEL0	M Divider Value	N Divider Value	M/N Divider Value	
26.5625	0	0	24	3	8	212.5
26.5625	0	1	24	4	6	159.375
26.5625	1	0	24	6	4	106.25
26.5625	1	1	24	12	2	53.125
26.04166	0	1	24	4	6	156.25
23.4375	0	0	24	3	8	187.5

**PIN ASSIGNMENT**

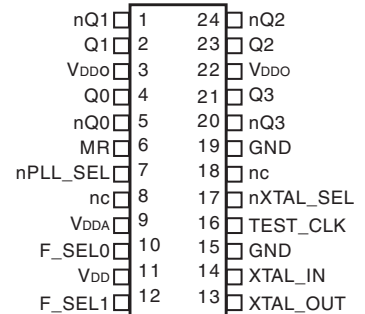

**ICS844004I**

**24-Lead TSSOP**

4.40mm x 7.8mm x 0.92mm

package body  
**G Package**  
Top View

**BLOCK DIAGRAM**

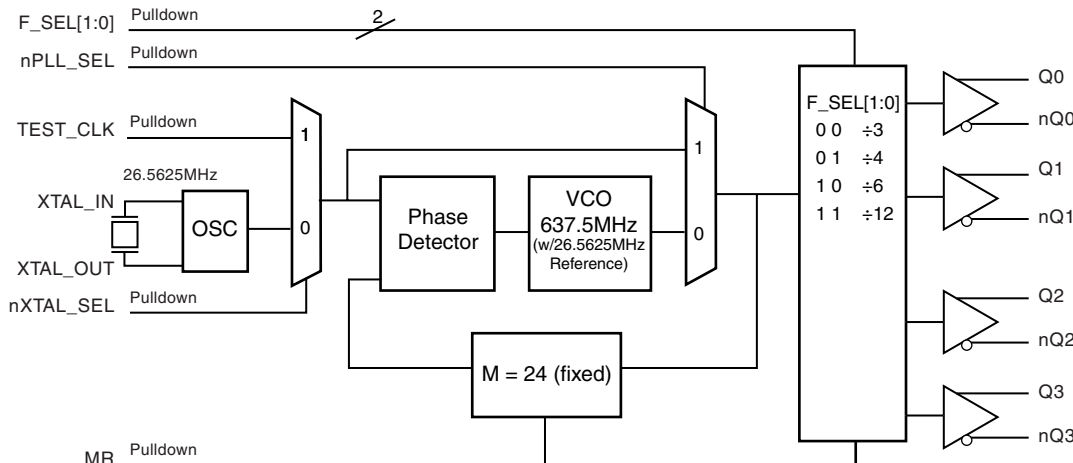

The Preliminary Information presented herein represents a product in prototyping or pre-production. The noted characteristics are based on initial product characterization. Integrated Circuit Systems, Incorporated (ICS) reserves the right to change any circuitry or specifications without notice.

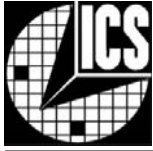

**TABLE 1. PIN DESCRIPTIONS**

Number	Name	Type		Description
1, 2	nQ1, Q1	Output		Differential output pair. LVDS interface levels.
3, 22	V <sub>DDO</sub>	Power		Output supply pins.
4, 5	Q0, nQ0	Output		Differential output pair. LVDS interface levels.
6	MR	Input	Pulldown	Active HIGH Master Reset. When logic HIGH, the internal dividers are reset causing the true outputs Qx to go low and the inverted outputs nQx to go high. When logic LOW, the internal dividers and the outputs are enabled. LVCMOS/LVTTL interface levels.
7	nPLL_SEL	Input	Pulldown	Selects between the PLL and TEST_CLK as input to the dividers. When LOW, selects PLL (PLL Enable). When HIGH, deselects the reference clock (PLL Bypass). LVCMOS/LVTTL interface levels.
8, 18	nc	Unused		No connect.
9	V <sub>DDA</sub>	Power		Analog supply pin.
10, 12	F_SEL0, F_SEL1	Input	Pulldown	Frequency select pins. LVCMOS/LVTTL interface levels.
11	V <sub>DD</sub>	Power		Core supply pin.
13, 14	XTAL_OUT, XTAL_IN	Input		Parallel resonant crystal interface. XTAL_OUT is the output, XTAL_IN is the input.
15, 19	GND	Power		Power supply ground.
16	TEST_CLK	Input	Pulldown	LVCMOS/LVTTL clock input.
17	nXTAL_SEL	Input	Pulldown	Selects between crystal or TEST_CLK inputs as the the PLL Reference source. Selects XTAL inputs when LOW. Selects TEST_CLK when HIGH. LVCMOS/LVTTL interface levels.
20, 21	nQ3, Q3	Output		Differential output pair. LVDS interface levels.
23, 24	Q2, nQ2	Output		Differential output pair. LVDS interface levels.

NOTE: *Pulldown* refers to internal input resistors. See Table 2, Pin Characteristics, for typical values.

**TABLE 2. PIN CHARACTERISTICS**

Symbol	Parameter	Test Conditions	Minimum	Typical	Maximum	Units
C <sub>IN</sub>	Input Capacitance			4		pF
R <sub>PULLDOWN</sub>	Input Pulldown Resistor			51		kΩ

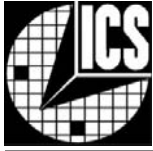

**ABSOLUTE MAXIMUM RATINGS**

Supply Voltage, $V_{CC}$	4.6V
Inputs, $V_i$	-0.5V to $V_{CC} + 0.5V$
Outputs, $I_o$	
Continuous Current	10mA
Surge Current	15mA
Package Thermal Impedance, $\theta_{JA}$	70°C/W (0 lfpm)
Storage Temperature, $T_{STG}$	-65°C to 150°C

NOTE: Stresses beyond those listed under Absolute Maximum Ratings may cause permanent damage to the device. These ratings are stress specifications only. Functional operation of product at these conditions or any conditions beyond those listed in the *DC Characteristics* or *AC Characteristics* is not implied. Exposure to absolute maximum rating conditions for extended periods may affect product reliability.

**TABLE 3A. POWER SUPPLY DC CHARACTERISTICS,  $V_{DD} = V_{DDA} = V_{DDO} = 3.3V \pm 5\%$ ,  $T_A = -40^\circ C$  TO  $85^\circ C$**

Symbol	Parameter	Test Conditions	Minimum	Typical	Maximum	Units
$V_{DD}$	Core Supply Voltage		3.135	3.3	3.465	V
$V_{DDA}$	Analog Supply Voltage		3.135	3.3	3.465	V
$V_{DDO}$	Output Supply Voltage		3.135	3.3	3.465	V
$I_{DD}$	Power Supply Current			TBD		mA
$I_{DDA}$	Analog Supply Current			TBD		mA
$I_{DDO}$	Output Supply Current			TBD		mA

**TABLE 3B. POWER SUPPLY DC CHARACTERISTICS,  $V_{DD} = V_{DDA} = V_{DDO} = 2.5V \pm 5\%$ ,  $T_A = -40^\circ C$  TO  $85^\circ C$**

Symbol	Parameter	Test Conditions	Minimum	Typical	Maximum	Units
$V_{DD}$	Core Supply Voltage		2.375	2.5	2.625	V
$V_{DDA}$	Analog Supply Voltage		2.375	2.5	2.625	V
$V_{DDO}$	Output Supply Voltage		2.375	2.5	2.625	V
$I_{DD}$	Power Supply Current			TBD		mA
$I_{DDA}$	Analog Supply Current			TBD		mA
$I_{DDO}$	Output Supply Current			TBD		mA

**TABLE 3C. LVCMOS / LVTTTL DC CHARACTERISTICS,  $V_{DD} = V_{DDA} = V_{DDO} = 3.3V \pm 5\%$  OR  $2.5V \pm 5\%$ ,  $T_A = -40^\circ C$  TO  $85^\circ C$**

Symbol	Parameter	Test Conditions	Minimum	Typical	Maximum	Units
$V_{IH}$	Input High Voltage	$V_{DD} = 3.3V$	2		$V_{DD} + 0.3$	V
		$V_{DD} = 2.5V$	1.7		$V_{DD} + 0.3$	V
$V_{IL}$	Input Low Voltage	$V_{DD} = 3.3V$	-0.3		0.8	V
		$V_{DD} = 2.5V$	-0.3		0.7	V
$I_{IH}$	Input High Current	TEST_CLK, MR, F_SEL0, F_SEL1, nPLL_SEL, nXTAL_SEL $V_{DD} = V_{IN} = 3.465$ or $2.625V$			150	$\mu A$
$I_{IL}$	Input Low Current	TEST_CLK, MR, F_SEL0, F_SEL1, nPLL_SEL, nXTAL_SEL $V_{DD} = 3.465V$ or $2.625V$ , $V_{IN} = 0V$	-150			$\mu A$



**TABLE 3D. LVDS DC CHARACTERISTICS,  $V_{DD} = V_{DDA} = V_{DDO} = 3.3V \pm 5\%$ ,  $T_A = -40^\circ\text{C}$  TO  $85^\circ\text{C}$**

Symbol	Parameter	Test Conditions	Minimum	Typical	Maximum	Units
$V_{OD}$	Differential Output Voltage			350		mV
$\Delta V_{OD}$	$V_{OD}$ Magnitude Change			40		mV
$V_{OS}$	Offset Voltage			1.45		V
$\Delta V_{OS}$	$V_{OS}$ Magnitude Change			50		mV

**TABLE 3E. LVDS DC CHARACTERISTICS,  $V_{DD} = V_{DDA} = V_{DDO} = 2.5V \pm 5\%$ ,  $T_A = -40^\circ\text{C}$  TO  $85^\circ\text{C}$**

Symbol	Parameter	Test Conditions	Minimum	Typical	Maximum	Units
$V_{OD}$	Differential Output Voltage			350		mV
$\Delta V_{OD}$	$V_{OD}$ Magnitude Change			40		mV
$V_{OS}$	Offset Voltage			1.2		V
$\Delta V_{OS}$	$V_{OS}$ Magnitude Change			50		mV

**TABLE 4. CRYSTAL CHARACTERISTICS**

Parameter	Test Conditions	Minimum	Typical	Maximum	Units
Mode of Oscillation		Fundamental			
Frequency		23.33	26.5625	28.33	MHz
Equivalent Series Resistance (ESR)				50	$\Omega$
Shunt Capacitance				7	pF
Drive Level				1	mW

NOTE: Characterized using an 18pF parallel resonant crystal.

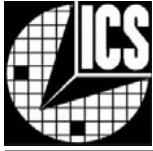

**TABLE 5A. AC CHARACTERISTICS,  $V_{DD} = V_{DDA} = V_{DDO} = 3.3V \pm 5\%$ ,  $T_A = -40^\circ\text{C}$  TO  $85^\circ\text{C}$**

Symbol	Parameter	Test Conditions	Minimum	Typical	Maximum	Units
$f_{OUT}$	Output Frequency	F_SEL[1:0] = 00	186.67		226.66	MHz
		F_SEL[1:0] = 01	140		170	MHz
		F_SEL[1:0] = 10	93.33		113.33	MHz
		F_SEL[1:0] = 11	46.67		56.66	MHz
t <sub>sk(o)</sub>	Output Skew; NOTE 1, 2		TBD		ps	
$f_{jit}(\emptyset)$	RMS Phase Jitter (Random); NOTE 3	212.5MHz, (637kHz - 10MHz)		0.65		ps
		159.375MHz, (637kHz - 10MHz)		0.61		ps
		156.25MHz, (637kHz - 10MHz))		0.74		ps
		106.25MHz, (637kHz -10MHz)		0.64		ps
		53.125MHz, (637kHz - 10MHz)		0.80		ps
t <sub>R</sub> / t <sub>F</sub>	Output Rise/Fall Time	20% to 80%		400		ps
odc	Output Duty Cycle			50		%

NOTE 1: Defined as skew between outputs at the same supply voltages and with equal load conditions.  
Measured at  $V_{DDO}/2$ .

NOTE 2: This parameter is defined in accordance with JEDEC Standard 65.

NOTE 3: Please refer to the Phase Noise Plot.

**TABLE 5B. AC CHARACTERISTICS,  $V_{DD} = V_{DDA} = V_{DDO} = 2.5V \pm 5\%$ ,  $T_A = -40^\circ\text{C}$  TO  $85^\circ\text{C}$**

Symbol	Parameter	Test Conditions	Minimum	Typical	Maximum	Units
$f_{OUT}$	Output Frequency	F_SEL[1:0] = 00	186.67		226.66	MHz
		F_SEL[1:0] = 01	140		170	MHz
		F_SEL[1:0] = 10	93.33		113.33	MHz
		F_SEL[1:0] = 11	46.67		56.66	MHz
t <sub>sk(o)</sub>	Output Skew; NOTE 1, 2		TBD		ps	
$f_{jit}(\emptyset)$	RMS Phase Jitter (Random); NOTE 3	212.5MHz, (637kHz - 10MHz)		0.65		ps
		159.375MHz, (637kHz - 10MHz)		0.61		ps
		156.25MHz, (637kHz - 10MHz))		0.74		ps
		106.25MHz, (637kHz -10MHz)		0.64		ps
		53.125MHz, (637kHz - 10MHz)		0.80		ps
t <sub>R</sub> / t <sub>F</sub>	Output Rise/Fall Time	20% to 80%		430		ps
odc	Output Duty Cycle			50		%

NOTE 1: Defined as skew between outputs at the same supply voltages and with equal load conditions.  
Measured at  $V_{DDO}/2$ .

NOTE 2: This parameter is defined in accordance with JEDEC Standard 65.

NOTE 3: Please refer to the Phase Noise Plot.



**PARAMETER MEASUREMENT INFORMATION**

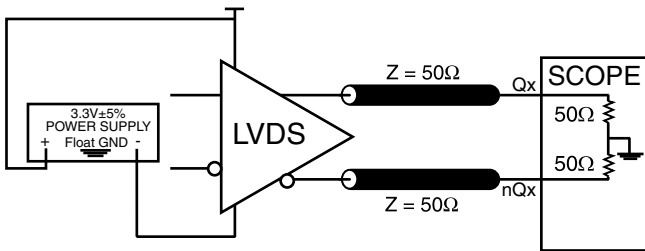

**3.3V CORE/3.3V OUTPUT LOAD AC TEST CIRCUIT**

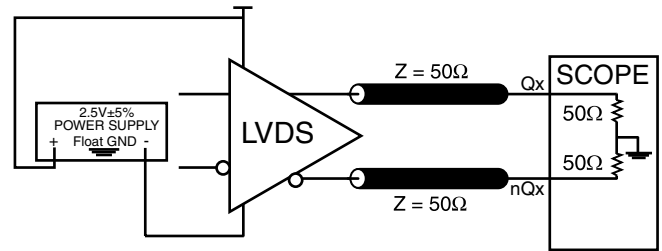

**2.5V CORE/2.5V OUTPUT LOAD AC TEST CIRCUIT**

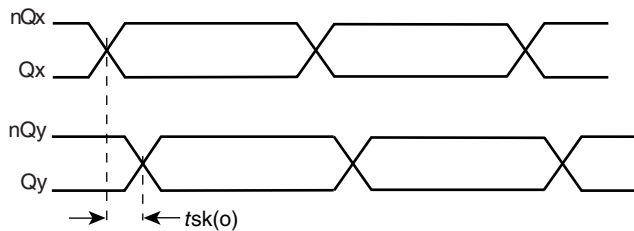

**OUTPUT SKEW**

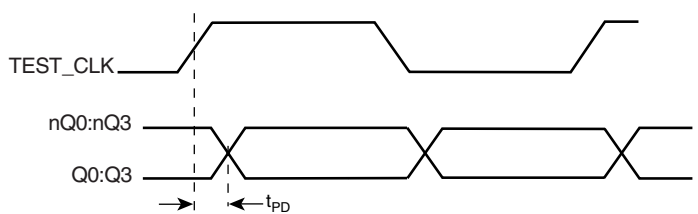

**PROPAGATION DELAY**

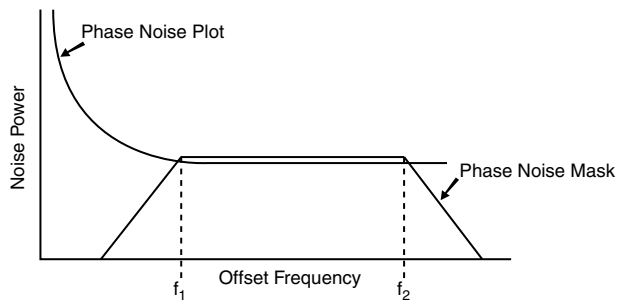

$$\text{RMS Jitter} = \sqrt{\text{Area Under the Masked Phase Noise Plot}}$$

**RMS PHASE JITTER**

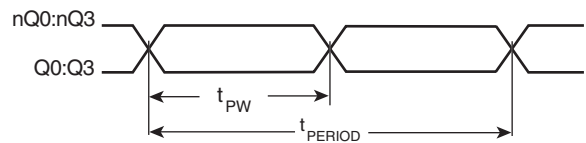

$$\text{odc} = \frac{t_{PW}}{t_{PERIOD}} \times 100\%$$

**OUTPUT DUTY CYCLE/PULSE WIDTH/PERIOD**

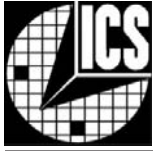

Integrated  
Circuit  
Systems, Inc.

**PRELIMINARY**

**ICS844004I**  
FEMTOCLOCKS™ CRYSTAL-TO-  
LVDS FREQUENCY SYNTHESIZER

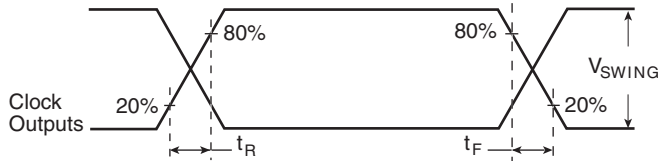

**OUTPUT RISE/FALL TIME**

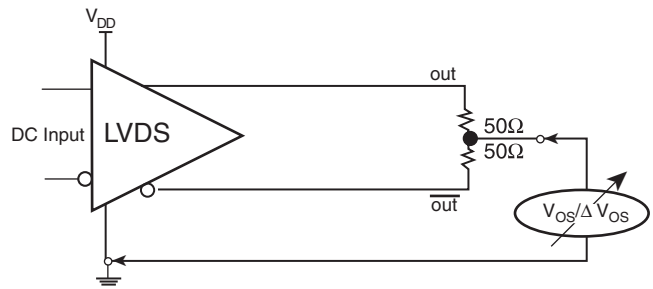

**OFFSET VOLTAGE SETUP**

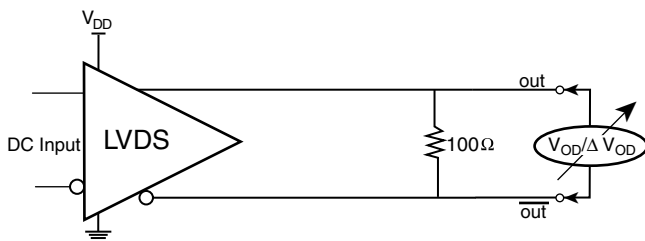

**DIFFERENTIAL OUTPUT VOLTAGE SETUP**

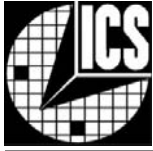

## APPLICATION INFORMATION

### POWER SUPPLY FILTERING TECHNIQUES

As in any high speed analog circuitry, the power supply pins are vulnerable to random noise. The ICS844004I provides separate power supplies to isolate any high switching noise from the outputs to the internal PLL.  $V_{DD}$ ,  $V_{DDA}$ , and  $V_{DDO}$  should be individually connected to the power supply plane through vias, and bypass capacitors should be used for each pin. To achieve optimum jitter performance, power supply isolation is required. *Figure 1* illustrates how a  $10\Omega$  resistor along with a  $10\mu\text{F}$  and a  $.01\mu\text{F}$  bypass capacitor should be connected to each  $V_{DDA}$ .

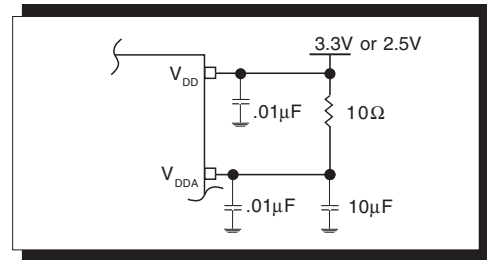
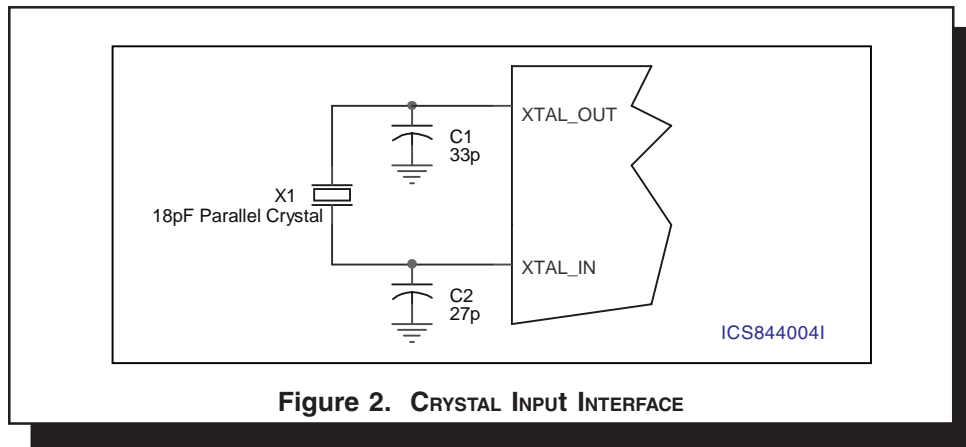

**FIGURE 1. POWER SUPPLY FILTERING**

### CRYSTAL INPUT INTERFACE

The ICS844004I has been characterized with 18pF parallel resonant crystals. The capacitor values shown in *Figure 2*

below were determined using a 26.5625MHz 18pF parallel resonant crystal and were chosen to minimize the ppm error.



**Figure 2. CRYSTAL INPUT INTERFACE**

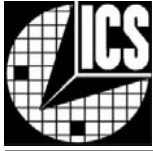

### 3.3V, 2.5V LVDS DRIVER TERMINATION

A general LVDS interface is shown in *Figure 3*. In a 100Ω differential transmission line environment, LVDS drivers require a matched load termination of 100Ω across near

the receiver input. For a multiple LVDS outputs buffer, if only partial outputs are used, it is recommended to terminate the un-used outputs.

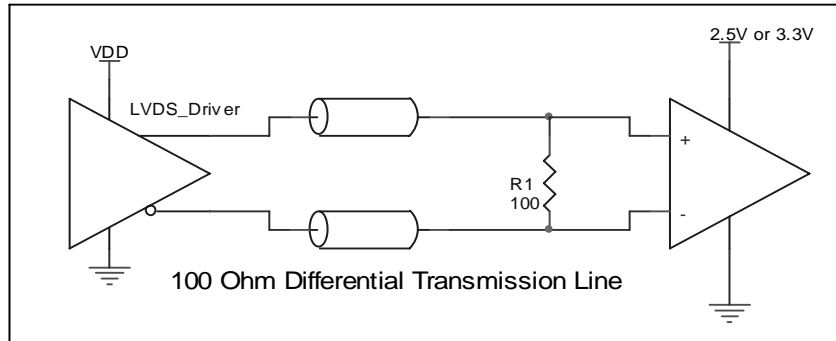

**FIGURE 3. TYPICAL LVDS DRIVER TERMINATION**



Integrated  
Circuit  
Systems, Inc.

**PRELIMINARY**

**ICS844004I**  
FEMTOCLOCKS™ CRYSTAL-TO-  
LVDS FREQUENCY SYNTHESIZER

**RELIABILITY INFORMATION**

**TABLE 6.  $\theta_{JA}$  VS. AIR FLOW TABLE FOR 24 LEAD TSSOP**

$\theta_{JA}$ by Velocity (Meters per Second)			
	0	1	2.5
Multi-Layer PCB, JEDEC Standard Test Boards	70°C/W	65°C/W	62°C/W

**TRANSISTOR COUNT**

The transistor count for ICS844004I is: 2914



PACKAGE OUTLINE - G SUFFIX FOR 24 LEAD TSSOP

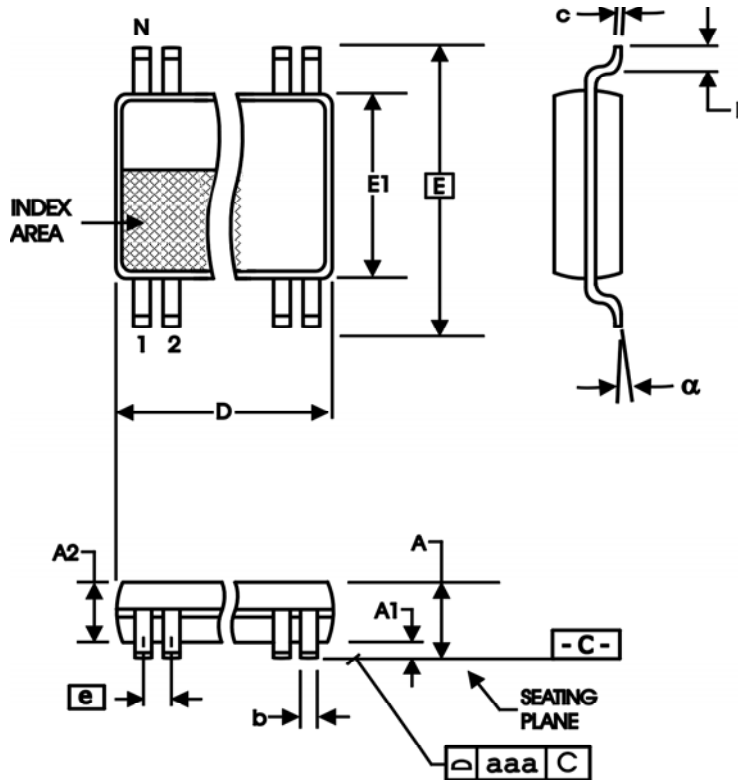

TABLE 7. PACKAGE DIMENSIONS

SYMBOL	Millimeters	
	Minimum	Maximum
N	24	
A	--	1.20
A1	0.05	0.15
A2	0.80	1.05
b	0.19	0.30
c	0.09	0.20
D	7.70	7.90
E	6.40 BASIC	
E1	4.30	4.50
e	0.65 BASIC	
L	0.45	0.75
alpha	0°	8°
aaa	--	0.10

Reference Document: JEDEC Publication 95, MO-153



Integrated  
Circuit  
Systems, Inc.

**PRELIMINARY**

**ICS844004I**  
**FEMTOCLOCKS™ CRYSTAL-TO-**  
**LVDS FREQUENCY SYNTHESIZER**

**TABLE 9. ORDERING INFORMATION**

<b>Part/Order Number</b>	<b>Marking</b>	<b>Package</b>	<b>Shipping Packaging</b>	<b>Temperature</b>
ICS844004AGI	ICS844004AGI	24 Lead TSSOP	tube	-40°C to 85°C
ICS844004AGIT	ICS844004AGI	24 Lead TSSOP	2500 tape & reel	-40°C to 85°C

The aforementioned trademarks, HiPerClockS™ and FEMTOCLOCKS™ are trademarks of Integrated Circuit Systems, Inc. or its subsidiaries in the United States and/or other countries. While the information presented herein has been checked for both accuracy and reliability, Integrated Circuit Systems, Incorporated (ICS) assumes no responsibility for either its use or for infringement of any patents or other rights of third parties, which would result from its use. No other circuits, patents, or licenses are implied. This product is intended for use in normal commercial and industrial applications. Any other applications such as those requiring high reliability or other extraordinary environmental requirements are not recommended without additional processing by ICS. ICS reserves the right to change any circuitry or specifications without notice. ICS does not authorize or warrant any ICS product for use in life support devices or critical medical instruments.