



050-301

Size 8 Cavity Opto-Electronic Contact

1.25mm ARINC 801 Terminus, 100Mbps – 4.25Gbps

Size 8 cavity opto-electronic contact

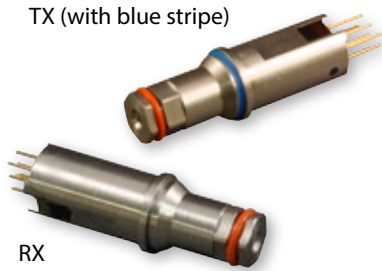

Patent Pending

Size 8 Cavity Opto-electronic contacts transmit and receive differential CML electrical signals over Multimode fiber optic cable. Transmitters consist of a laser driver with a temperature compensation circuit to maintain optical power over the entire operating temperature range, and a 850nm VCSEL laser. Receivers consist of an 850nm PIN Photo Detector, a Transimpedance Amplifier with automatic gain control circuit, and a Limiting Amplifier. Differential output data signals are CML compatible. The transmitter has a Tx Disable pin to turn off transmitter output and a Tx Fault pin to signal a fault condition. Receiver includes a CMOS compatible Loss of Signal Indicator to prevent invalid data.

KEY FEATURES

- Front-release, front-insert, front-removable Size #8 OE converter designed for ARINC 600
- ARINC 664, 801, 803, 804, and 818 standard Compliant
- Data rates from 100Mbps to 4.25 Gbps
- Supports Fast and Gigabit Ethernet, AFDX, 1x/2x Fibre Channel, DVI, HDMI, SFPDP, Serial Rapid I/O (sRIO).
- 100 ohms differential CML inputs with Tx Fault and Tx Disable
- Link distances up to 550 meters with multimode 50/125µm or 62.5/125 µm fiber
- Single 3.3v power supply
- ARINC 801 1.25mm ceramic fiber ferrule

How To Order

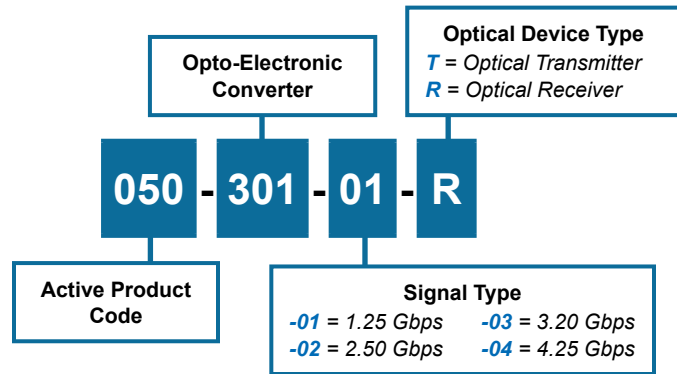

Material/Finish	
Shell	300CRES/Passivate or NM6
Seal	Silicone elastomer
Fiber ferrule & sleeve	Zirconia ceramic
PC tail contacts	Copper alloy/gold plated
PCB flex	FR4 & Polyimide
Solder type	RoHS compliant Sn95/Sb5 (232°C melting temp) & RoHS compliant Sn96.5/Ag3.0/Cu0.5 (217° melting)

050-301
Size 8 Cavity Opto-Electronic Contact
1.25mm ARINC 801 Terminus, 100Mbps – 4.25Gbps

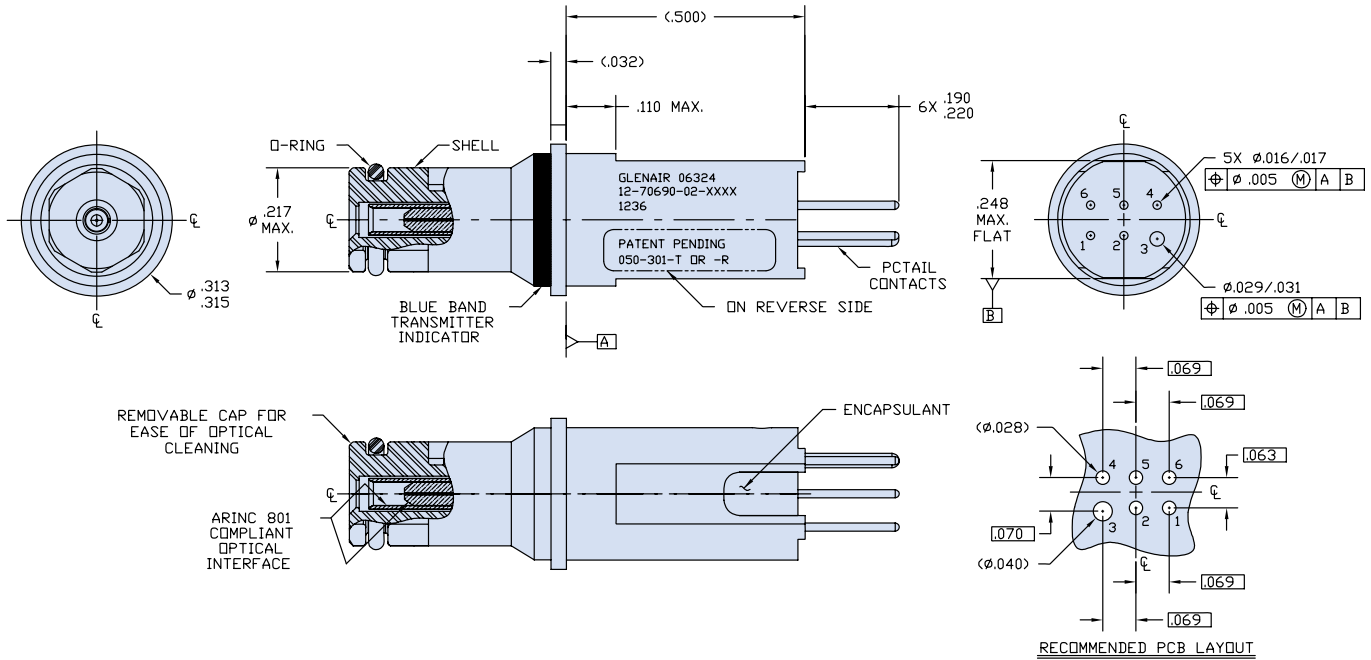

Component Replacement Part Numbers

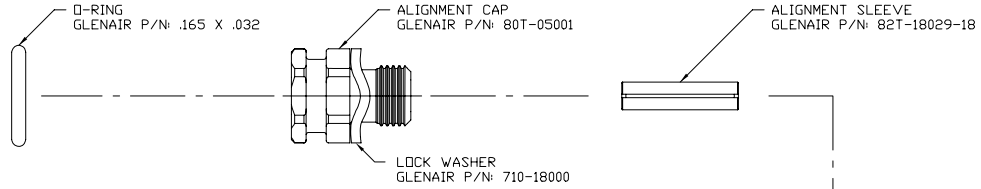

RECOMMENDED

Dry action cleaning tool



GCLT - C125

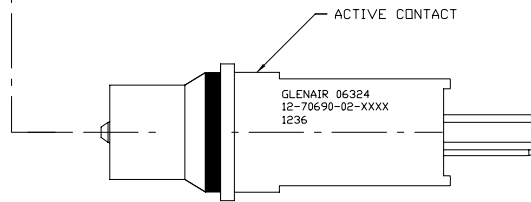

Notes

- Contact fits inside Radiall & Souriau ARINC 600 Q11 insert layout - Size 8 Quadrax front release/front removable cavity.
- When installed in ARINC 600 receptacle Q11 insert, this contact couples with ARINC 801 fiber optic contact encased in ARINC 600 female Quadrax adapter.
- This contact, when installed in Radiall or Souriau ARINC 600 receptacle with RoHS compliant stand-off will meet applicable optical, mechanical and environmental performance requirements of ARINC 801 contact and ARINC 600 connector.
- Cap may be removed to provide access for fiber tip cleaning, or to replace alignment sleeve.
- Laser safety information: Class 1 21CFR1040.10
- Contact is RoHS compliant.
- Recommended PCB installation soldering contacts can withstand locally applied soldering heating of pins typical RoHS compliant solder temperature of 260°C and typical time of 10 seconds.

Transmitter

Recommended Interface Circuit

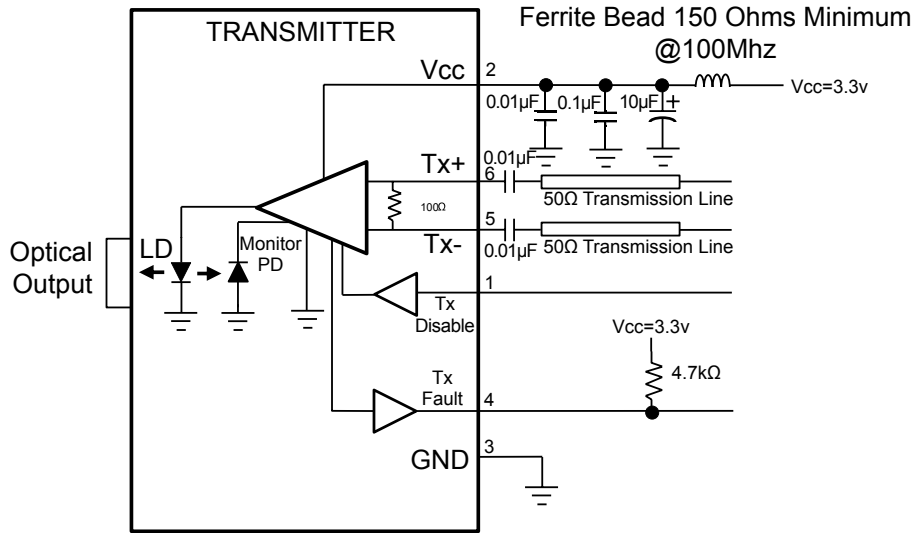

Absolute Max. Rating: Transmitter					
Parameter	Symbol	Min.	Typ.	Max.	Unit
Storage Temperature	T _s	-55		+100	°C
Supply Voltage	V _{cc}	-0.4		+4	V
Tx Disable Input Voltage	V _{Disable}	-0.4		V _{cc}	V

Transmitter Power Supply Current V _{cc} = 3.14 to 3.46V					
Parameter	Symbol	Min.	Typ.	Max	Unit
Supply Current	I _{cc}	50		90	mA

Transmitter: Example Optical Link Distances		
Protocol	Fiber Type	Distance
Gigabit Ethernet	62.5/125µm, 200MHZ*Km	275 Meters
	50/125µm, 500MHZ*Km	550 Meters

Optical Transmitter					
Parameter	Symbol	Min.	Typ.	Max.	Unit
Optical Output Power	P _{out}	-6.5		-1.5	dBm
Optical Wavelength	λ _{Out}	830	850	860	nm
Spectral Width	DI _{rms}			0.85	nm
Extinction Ratio	Er	6.0	10		dB
-01 (1.25 bps)					
-02 (2.50 bps)					
-03 (3.20 bps)					
-04 (4.25 bps)					
Total Jitter	TJ			60	ps

Operating Conditions: Transmitter					
Parameter	Symbol	Min.	Typ.	Max.	Unit
Operating Temperature	T _{op}	-40		+85	°C
Supply Voltages	V _{cc}	3.14	3.3	3.46	V
Differential Input Voltage	V _{id}	250		2200	mVp-p
Power Supply Noise	V _{CC} Ripple			0.15	Vp-p

Electrical Pin Arrangement: Transmitter			
Pin	Symbol	Description	Logic
1	TX Disable	Transmit Disable (Input) Logic "1" Input → Disable Transmitter Output	CMOS Internal 4.7KOhm pulldown
2	V _{cc}	Power Supply	
3	GND	Signal Ground	
4	TX Fault	Transmitter Fault Indicator (Output) Logic "1" Output → Transmitter Fault Condition	CMOS Open Drain
5	TX-	Transmitter Inverted Data (Input)	CML (Current Mode Logic)
6	TX+	Transmitter Non-Inverted Data (Input)	CML (Current Mode Logic)

Note: 50 µm fiber output

050-301
Size 8 Cavity Opto-Electronic Contact
1.25mm ARINC 801 Terminus, 100Mbps – 4.25Gbps



Receiver

Recommended Interface Circuit

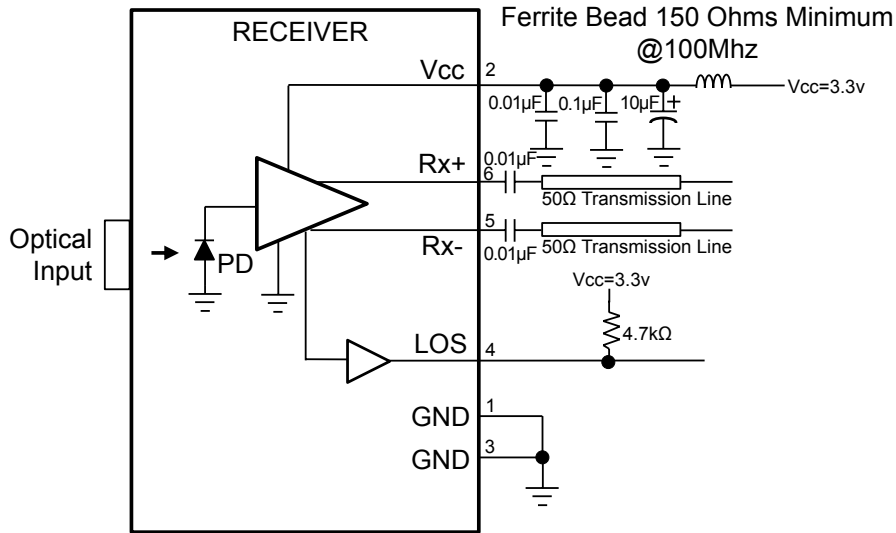

Absolute Max. Rating: Receiver					
Parameter	Symbol	Min.	Typ.	Max.	Unit
Storage Temperature	T _s	-55		+100	°C
Operating Voltage	V _{cc}	-0.4		+4	V

Operating Conditions: Receiver					
Parameter	Symbol	Min.	Typ.	Max.	Unit
Operating Temperature	T _{op}	-40		+85	°C
Supply Voltages	V _{cc}	3.14	3.3	3.46	V
Power Supply Noise	V _{CC} Ripple			0.15	V

Receiver Power Supply Current V _{cc} = 3.14 to 3.46V, Over Top					
Parameter	Symbol	Min.	Typ.	Max.	Unit
Supply Current	I _{cc}			90	mA

Optical Receiver					
Parameter	Symbol	Min.	Typ.	Max.	Unit
Optical Sensitivity 125 Mbps-1.25 Gbps ER=9dB, PRBS 2 ⁷ -1 BER=10 ⁻¹²		-17			dBm
-01 = 125 Mbps		-17			dBm
-01 = 1.25 Gbps		-17			dBm
-02 = 2.50 Gbps		-15			dBm
-03 = 3.20 Gbps		-15			dBm
-04 = 4.25 Gbps		-14			dBm
Optical Overload				0	dBm
Optical Wavelength	λ _{out}	830		860	nm
Differential Output Swing (P-P)	V _d diff	600		1200	mV
LOS Assert Level	LOS _h		-24	-22	dBm
LOS Hysteresis	LOS _{HYS}	1.5	2.3		dB

Electrical Pin Arrangement - Receiver			
Pin	Symbol	Description	Logic
1	GND	Signal Ground	
2	V _{cc}	Power Supply	
3	GND	Signal Ground	
4	LOS	Loss of Signal (Output) Loss of Valid Optical Signal → Logic "1" Output	CMOS Open Drain
5	RX-	Receiver Inverted Data (Output)	CML (Current Mode Logic)
6	RX+	Receiver Non-Inverter Data (Output)	CML (Current Mode Logic)

Note: 62.5 µm fiber input