

正向10.0前插后贴/6.80

MAPX	MODIFICATION	DATE

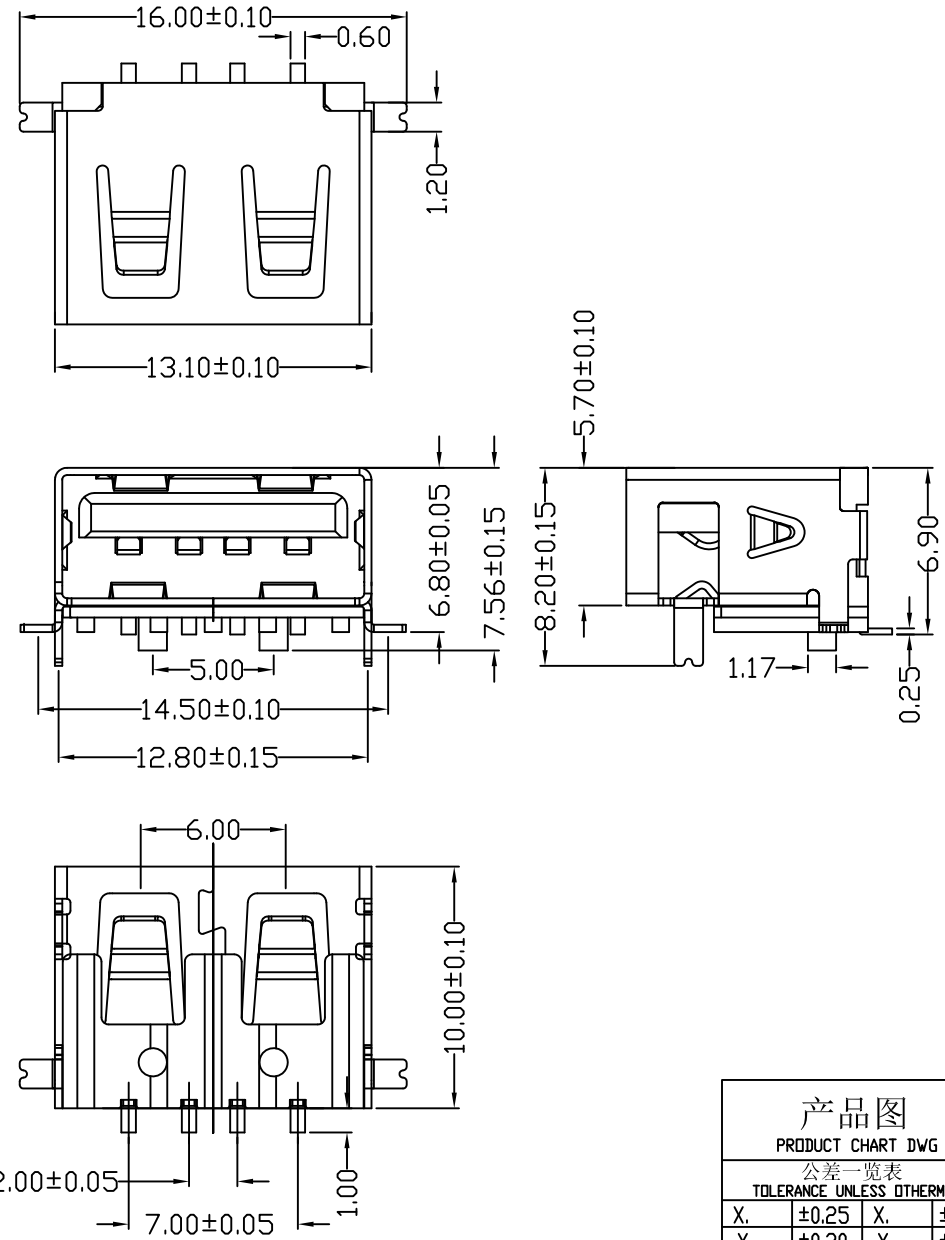

NOTES:
 1.HOUSING: SEE NOTES, UL94V-0 .
 TERMINAL: SEE NOTES.
 SHELL: SEE NOTES.
 SPECIFICATION:
 1.ELECTRICAL CHARACTERISTIC:
 CONTACT RESISTANCE: 30MΩ MAX
 DIELECTRIC WITHSTANDING VOLTAGE: 500V AC FOR 1MIN
 INSULATION RESISTANCE: 1000MΩ MIN
 2.MECHANICAL CHARACTERISTIC:
 INSERTION FORCE: 35N(3.57KGF) MAX
 EXTRACTION FORCE: 10~35N(1.02~3.57KGF)MIN
 DURABILITY: 1500 CYCLES EXTRACTION FORCE:10~35N
 5000 CYCLES MIN
 5000 CYCLES EXTRACTION FORCE:3~35N

3.ENVIRONMENTAL:
 OPERATING TEMPERATURE: -55°C+85°C
 4.Contact finish:
 01:Selective Gold Flash
 02:Selective Gold 3U"
 03:Selective Gold 5U"
 04:Selective Gold 15U"
 05:Selective Gold 30U"

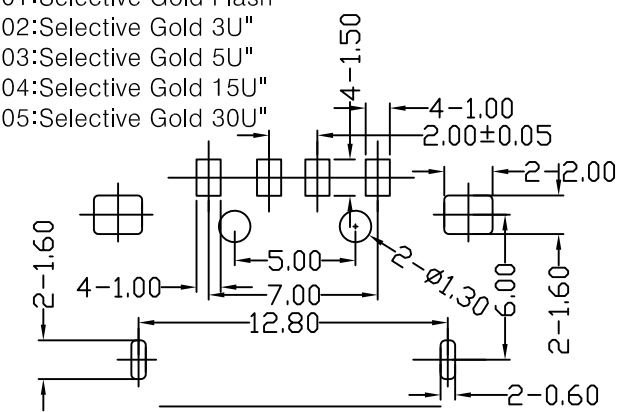

FRONT EDGE OF CONNECTOR
PCB LAYOUT

产品图 PRODUCT CHART DWG 公差一览表 TOLERANCE UNLESS OTHERWISE				深圳市精拓金电子有限公司							
X.	±0.25	X.	±5°	单位	MM	制图	Z-Y-B	制图料号	915-221A2028S10200		
.X	±0.20	.X	±2°	比例	1:1	审核		产品名称	AF10.0短体前插后贴无边方弹铁壳 LCP黑胶6.8有柱		
.XX	±0.15	.XX	±1°	日期	2013.04.24	核准		角法	版本	AD	
.XXX	±0.10	.XXX	±0.5°	DATE		APPD		VIEW	VER		