

## KDT3002A

The KDT3002A is high sensitivity NPN silicon photo transistor mounted in  $\Phi 3\text{mm}$ (T-1) all plastic mold type. This photo transistor is both compact and easy to mount.

### Features

- Highly sensitive photo transistor
- Visible ray cut off mold type

### Applications

- VCR, Camcoders
- Floppy disk drivers
- Optical detectors/switch

### Dimensions

[Unit : mm]

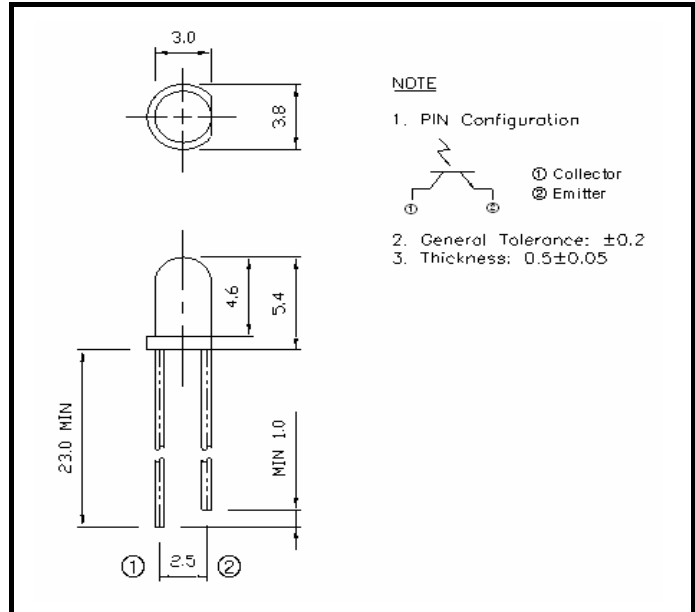

### Absolute Maximum Ratings

[ $T_A = 25^\circ\text{C}$ ]

Parameter	Symbol	Rating	Unit
Collector-Emitter Voltage	$V_{CEO}$	35	V
Emitter-Collector Voltage	$V_{ECO}$	6	V
Collector Current	$I_C$	20	mA
Collector Power Dissipation	$P_C$	75	mW
Operating Temperature	$T_{opr.}$	-20~+85	$^\circ\text{C}$
Storage Temperature	$T_{stg.}$	-30~+85	$^\circ\text{C}$
Soldering Temperature* <sup>1</sup>	$T_{sol}$	240	$^\circ\text{C}$

Notes : 1. For MAX. 5 seconds at the position of 3 mm from the package.

### ELECTRO- OPTICAL CHARACTERISTICS

Description	Symbol	Condition	Min.	Typ.	Max.	Unit
Dark Current	$I_{CEO}$	$V_{CE}=10\text{V}, E_E=0$	-	-	200	nA
Light Current	$I_{CEL}$	$V_{CE}=10\text{V}, E_v=500\text{lX} \text{ ※1}$	2.5	5.0	-	mA
Spectral Sensitivity	$\lambda$	-	700~1050			nm
Peak wavelength	$\lambda_p$	$V_R=0\text{V}$	-	880	-	nm
Viewing Angle	$\Delta\theta$	-	-	$\pm 30$	-	deg.
Response Time(Rise Time)	$t_r$	$V_{CC}=10\text{V}, I_C=1\text{mA}$	-	2.5	-	$\mu\text{s}$
Response Time(Fall Time)	$t_f$	$\lambda_L=100\Omega$	-	4.7	-	$\mu\text{s}$

※1 Color temp. =2856K Standard Tungsten lamp

**KDT3002A**

**DYNAMIC CHARACTERISTICS**

**Power dissipation Vs. Ambient temperature**

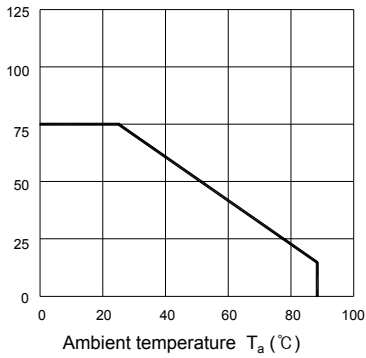

**Collector current Vs. Irradiance**

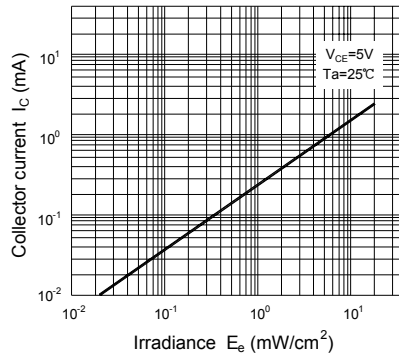

**Dark current Vs. Ambient temperature**

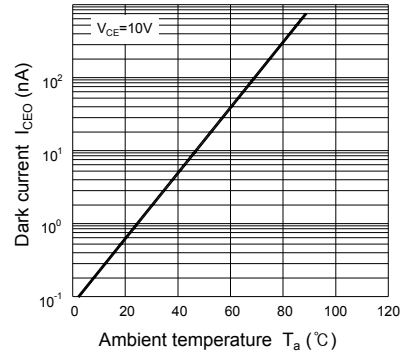

**Collector current Vs. Collector-Emitter voltage**

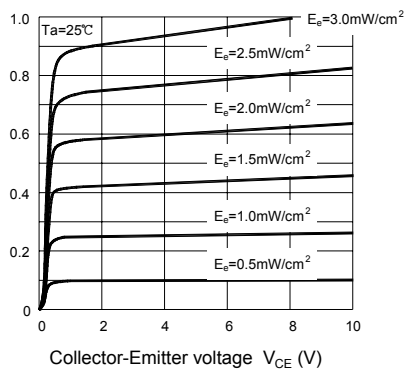

**Relative sensitivity Vs. Wavelength**

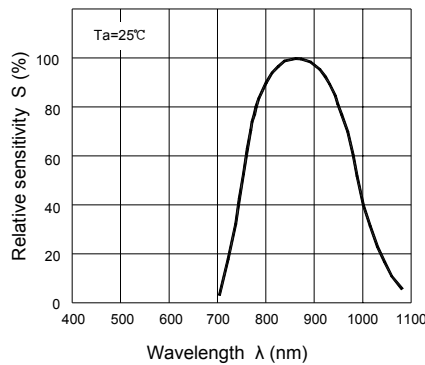

**Radiant pattern**

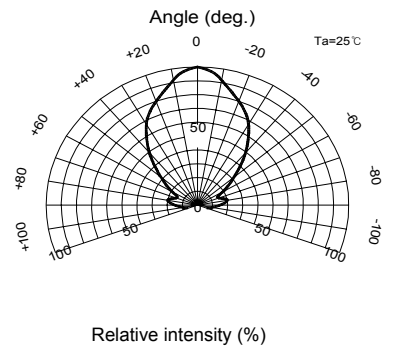

**Response time Vs. Load resistance**

