

RoHS Compliant Product

## Description

The SL1118 is a low dropout at positive adjustable or fixed-mode regulator with min. of 0.8A output current capability. The product is specifically designed to provide well-regulated supply for low voltage IC applications such as high-speed bus termination and low current 3.3V logic supply. SL1118 is also well suited for other applications such as VGA cards. SL1118 is guaranteed to have lower than 1.3V dropout at full load current making it ideal to provide well regulated outputs of 1.25V to 5V with up to 12V input supply.

## SOT-223

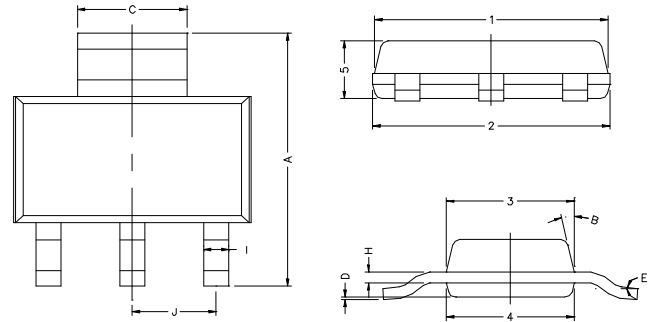

## Features

- \* 1.4V Max. Dropout Full Load Current
- \* 3-Terminal Adjustable or Fixed 1.5V, 1.8V, 2.5V, 3.3V, 5.0V
- \* Output Current Limiting
- \* Good Noise Rejection
- \* Fast Transient Response
- \* Built-in Thermal Shutdown

REF.	Millimeter		REF.	Millimeter	
	Min.	Max.		Min.	Max.
A	6.70	7.30	B	13° TYP.	
C	2.90	3.10	J	2.30 REF.	
D	0.02	0.10	1	6.30	6.70
E	0°	10°	2	6.30	6.70
I	0.60	0.80	3	3.30	3.70
H	0.25	0.35	4	3.30	3.70
			5	1.40	1.80

## Applications

- \* PC Peripheral
- \* Communication

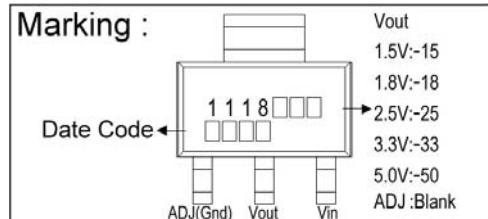

## Typical Circuit

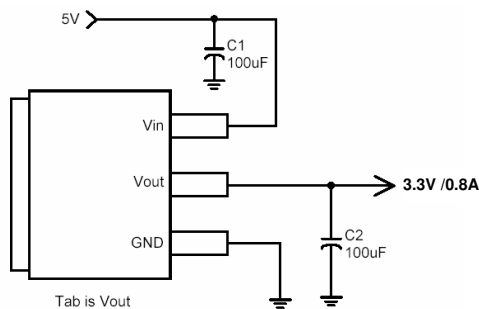

( 5V/3.3V fixed output )

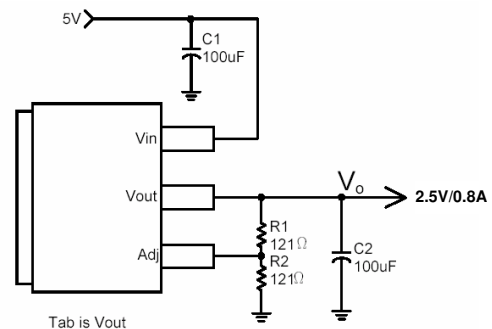

( 5V/2.5V ADJ output )

$$\text{Note: } V_o = V_{REF} * \left(1 + \frac{R_2}{R_1}\right)$$

## Block Diagram

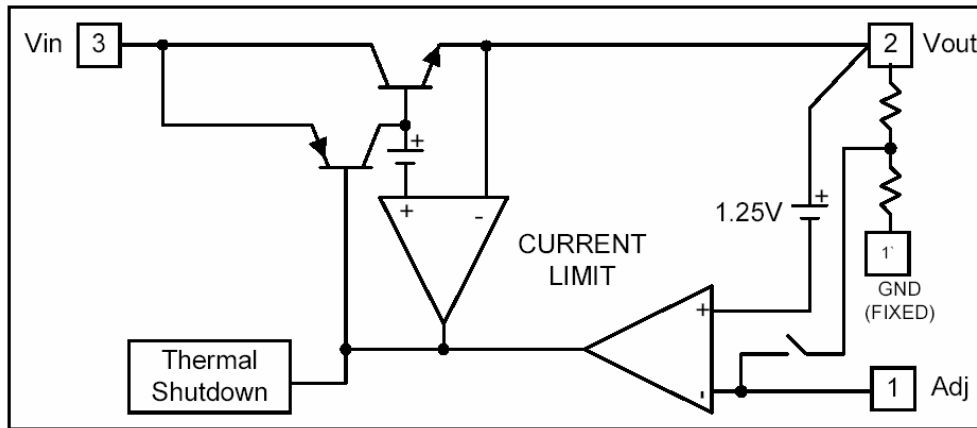

## Pin Descriptions

Name	I/O	Pin#	Function
Adj (GND)	I	1	A resistor divider from this pin to the Vout pin and ground sets the output voltage (Ground only for fixed mode)
Vout	O	2	The output of the regulator. A minimum of 10 $\mu$ F capacitor ( $0.15\Omega \leq \text{ESR} \leq 20\Omega$ ) must be connected from this pin to ground to insure stability.
Vin	I	3	The input pin of regulator. Typically a large storage capacitor ( $0.15\Omega \leq \text{ESR} \leq 20\Omega$ ) is connected from this pin to ground to insure that the input voltage does not sag below the minimum dropout voltage during the load transient response. This pin must always be 1.3V higher than Vout in order for the device to regulate properly.

## Absolute Maximum Ratings

Parameter	Symbol	Ratings	Unit
DC Supply Voltage	$V_{IN}$	-0.3 to 12	V
Power Dissipation	$P_D$	Internally Limited	
Storage Temperature Range	$T_{ST}$	-65~+150	$^{\circ}\text{C}$
Operating Junction Temperature Range	$T_{OP}$	0~+150	$^{\circ}\text{C}$

### Electrical Characteristics

Parameter	Conditions		Min	Typ	Max	Unit
Reference Voltage	SL1118ADJ	$I_o=10\text{mA}$ , $T_J=25^\circ\text{C}$ , $(V_{IN}-V_{OUT})=1.5\text{V}$	1.225	1.250	1.275	V
Output Voltage	SL1118-1.5	$I_o=10\text{mA}$ , $T_J=25^\circ\text{C}$ , $3\text{V} \leq V_{IN} \leq 12\text{V}$	1.470	1.500	1.530	V
	SL1118-1.8	$I_o=10\text{mA}$ , $T_J=25^\circ\text{C}$ , $3.3\text{V} \leq V_{IN} \leq 12\text{V}$	1.764	1.800	1.836	V
	SL1118-2.5	$I_o=10\text{mA}$ , $T_J=25^\circ\text{C}$ , $4\text{V} \leq V_{IN} \leq 12\text{V}$	2.450	2.500	2.550	V
	SL1118-3.3	$I_o=10\text{mA}$ , $T_J=25^\circ\text{C}$ , $4.8\text{V} \leq V_{IN} \leq 12\text{V}$	3.235	3.300	3.365	V
	SL1118-5.0	$I_o=10\text{mA}$ , $T_J=25^\circ\text{C}$ , $6.5\text{V} \leq V_{IN} \leq 12\text{V}$	4.900	5.000	5.100	V
Line Regulation	SL1118-XXX	$I_o=10\text{mA}$ , $V_{OUT}+1.5\text{V} < V_{IN} < 12\text{V}$ , $T_J=25^\circ\text{C}$	-	-	0.2	%
Load Regulation	SL1118ADJ	$V_{IN}=3.3\text{V}$ , $V_{adj}=0$ , $0\text{mA} < I_o < 0.8\text{A}$ , $T_J=25^\circ\text{C}$ (Note 1,2)	-	-	1	%
	SL1118-1.5	$V_{IN}=3\text{V}$ , $0\text{mA} < I_o < 0.8\text{A}$ , $T_J=25^\circ\text{C}$ (Note 1,2)	-	12	15	mV
	SL1118-1.8	$V_{IN}=3.3\text{V}$ , $0\text{mA} < I_o < 0.8\text{A}$ , $T_J=25^\circ\text{C}$ (Note 1,2)	-	15	18	mV
	SL1118-2.5	$V_{IN}=4\text{V}$ , $0\text{mA} < I_o < 0.8\text{A}$ , $T_J=25^\circ\text{C}$ (Note 1,2)	-	20	25	mV
	SL1118-3.3	$V_{IN}=5\text{V}$ , $0\text{mA} < I_o < 0.8\text{A}$ , $T_J=25^\circ\text{C}$ (Note 1,2)	-	26	33	mV
	SL1118-5.0	$V_{IN}=8\text{V}$ , $0\text{mA} < I_o < 0.8\text{A}$ , $T_J=25^\circ\text{C}$ (Note 1,2)	-	40	50	mV
Dropout Voltage ( $V_{IN}-V_{OUT}$ )	SL1118ADJ/1.5/ 1.8/2.5/3.3/5.0	$I_o=0.8\text{A}$ , $(\Delta V_{OUT} = 0.1\% V_{OUT})$	-	1.2	1.4	V
Current Limit	SL1118ADJ/1.5/ 1.8/2.5/3.3/5.0	$V_{IN}-V_{OUT}=5\text{V}$	0.9	-	-	A
Minimum Load Current	SL1118-XXX	$0^\circ\text{C} \leq T_J \leq 125^\circ\text{C}$	-	5	10	mA
Thermal Regulation	$T_A=25^\circ\text{C}$ , 30ms pulse		-	0.008	0.04	%/W
Ripple Rejection	$F=120\text{HZ}$ , $C_{OUT}=25\mu\text{F}$ Tantalum, $I_{OUT}=0.8\text{A}$					
	SL1118-XXX	$V_{IN}=V_{OUT}+3\text{V}$	-	60	70	dB
Temperature Stability	$I_o=10\text{mA}$		-	0.5	-	%
$\theta_{JA}$ Thermal Resistance Junction-to-Ambient(No heat sink ;No air flow)			-	117	-	$^\circ\text{C}/\text{w}$
$\theta_{JC}$ Thermal Resistance Junction-to-Case	Control Circuitry/Power Transistor		-	15	-	$^\circ\text{C}/\text{w}$

Note 1: See thermal regulation specifications for changes in output voltage due to heating effects. Line and load regulation are measured at a constant junction temperature by low duty cycle pulse testing. Load regulation is measured at the output lead =1/18" from the package.

Note 2: Line and load regulation are guaranteed up to the maximum power dissipation of 5W. Power dissipation is determined by the difference between input and output and the output current. Guaranteed maximum power dissipation will not be available over the full input/output range.

Note 3: Quiescent current is defined as the minimum output current required in maintaining regulation. At 12V input/output differential the device is guaranteed to regulate if the output current is greater than 10mA.

## Characteristics Curve

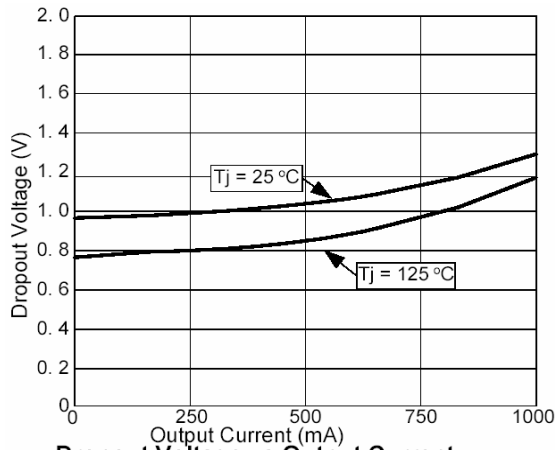

Dropout Voltage vs Output Current

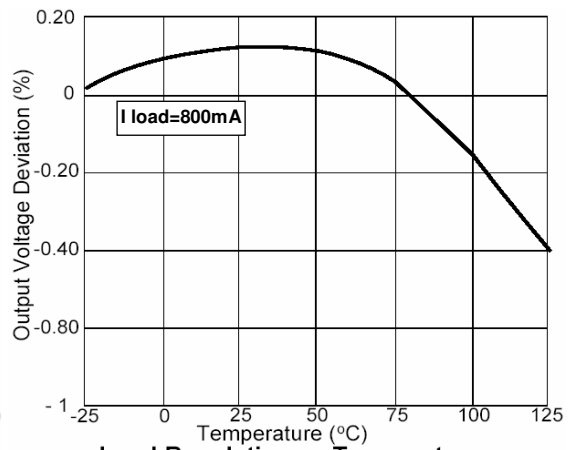

Load Regulation vs Temperature

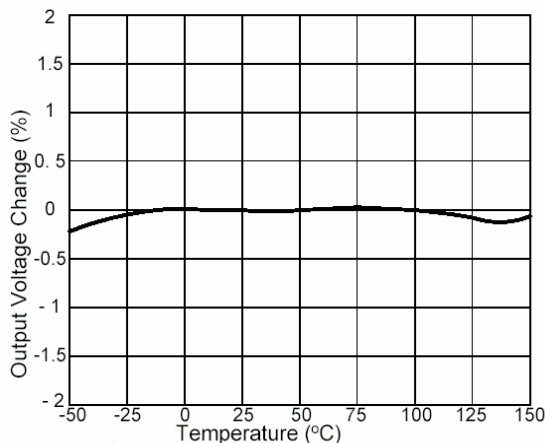

Percent Change in Output Voltage vs Temperature

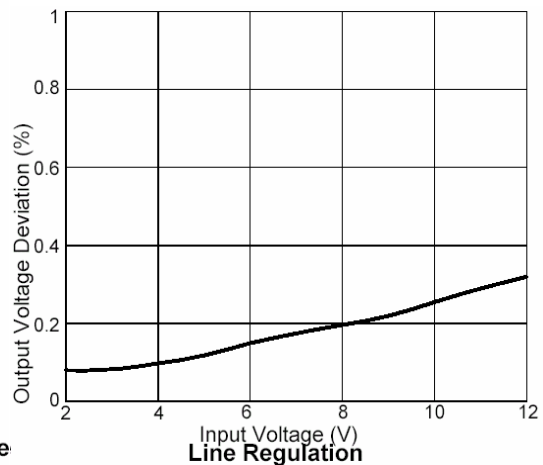

Line Regulation

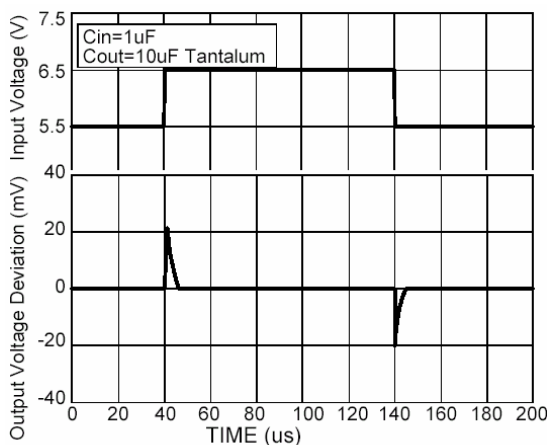

Line Transient Response

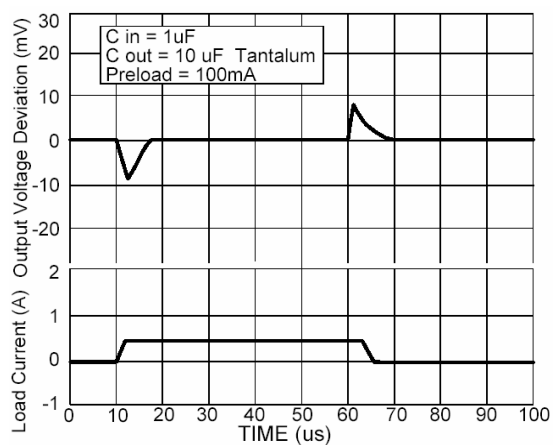

Load Transient Response