

Lightning Surge Protectors for Electronics Equipment M-RESTER

LIGHTNING SURGE PROTECTOR FOR POWER SUPPLY USE
(10 - 30 A; replaceable arrester module)

Functions & Features

- Designed specifically for power requirements of medium capacities (10 or 30 A)
- Separating the arrester module when a leak current is detected at the module
- Relay contact and front LED turn ON in case of the arrester module failure
- The plugin type arrester module can be easily replaced

Typical Applications

- Control panels
- Telemetering panels
- PLC panels
- Computer systems

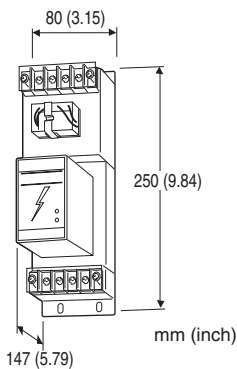

MODEL: MMH-[1][2]

ORDERING INFORMATION

- Code number: MMH-[1][2]
Specify a code from below for each [1], [2].
(e.g. MMH-130)

[1] OPERATIONAL VOLTAGE

- 1: 100 V/110 V AC
- 2: 200 V/220 V AC

[2] LOAD CURRENT

- 10: 10 A
- 30: 30 A

RELATED PRODUCTS

- Lightning surge protector for standard signal line use (model: MMD)
- Arrester module (model: MEH)

GENERAL SPECIFICATIONS

Construction: Wall-mounted, front terminals; terminal cover provided

Connection: M4 screw terminals (torque 1.6 N·m)

Screw terminal: Nickel-plated brass

Housing material: Steel plate t = 1.6 (black)

Monitor LED (arrester module)

- RUN: Green LED turns on in normal conditions
- ALARM: Red LED turns on in error

Alarm contact: turns ON when the arrester module (model: MEH) is failed or extracted or when the power supply is removed.

Rating: 110 V AC @ 1 A (cos ϕ = 1)
24 V DC @ 1 A (resistive load)

• Maximum switching voltage: 250 V AC or 125 V DC

• Maximum switching power: 110 VA or 24 W

• Minimum load: 12 V DC @ 10 mA

Alarm detecting current: Approx. 100 mA

INSTALLATION

Operating temperature: -5 to +55°C (23 to 131°F)

Operating humidity: 30 to 90 %RH (non-condensing)

Mounting: Surface

Weight: 3 kg (6.61 lbs)

PERFORMANCE

Operational voltage range:

- 90 - 120 V AC (MMH-1x)
- 180 - 242 V AC (MMH-2x)
- 50/60 Hz, 10 VA max.

AC discharge voltage (peak voltage)

- Line to line:
190 V min. (MMH-1x)
410 V min. (MMH-2x)
- Line to ground: 410 V min.

Maximum surge voltage (peak voltage)

- Line to line:
350 V max. (MMH-1x)
700 V max. (MMH-2x)
- Line to ground: 800 V max.

(Usable for those instruments which can withstand 1000 V AC between the circuit and housing)

Note: The maximum voltage that could pass through M-RESTER. Protected equipment must be able to withstand this voltage for very short time period.

Response time: $\leq 0.01 \mu\text{sec}$.

Leakage current

Line to line:

≤ 50 mA at 110 V AC (MMH-1x)

≤ 30 mA at 220 V AC (MMH-2x) including driving current for the MEH and relay

Line to ground: ≤ 1 mA at 220 V AC

Discharge current capacity: 10000 A (8/ 20 μsec.)

Maximum load current:

10 A (MMH-x10)

30 A (MMH-x30)

Voltage drop: ≤ 1 V (50/60 Hz)

ALARM CONTACT

If a leak current greater than approx. 100 mA is detected from the surge absorber element inside the MEH, the relay driver circuit turns on the alarm contact output of the MMH and the ALARM LED (red). When the alarm contact is output, unplug the MEH and then plug it back in to check the ALARM LED status and confirm that the element is failed. If the ALARM LED remains ON, install a new MEH module. (Refer to the instruction manual for MMH for replacing procedure.)

During NORMAL operation, it is possible for the ALARM LED to remain OFF and the ALARM contact to turn ON momentarily when experiencing lightning surges. Please continue use of the unit as this is standard operation.

CONNECTION EXAMPLES

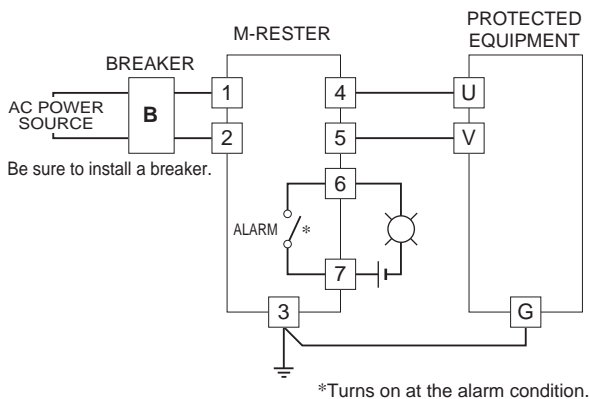

GROUNDING

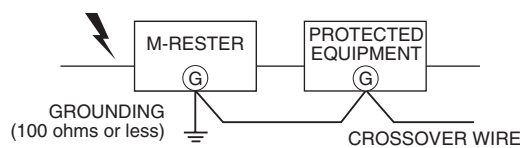

A crossover wire between M-RESTER ground and ground or metallic housing of equipment is required for protection. If the protected equipment has no ground terminal, ground the M-RESTER only.

EXTERNAL DIMENSIONS & TERMINAL ASSIGNMENTS unit: mm (inch)

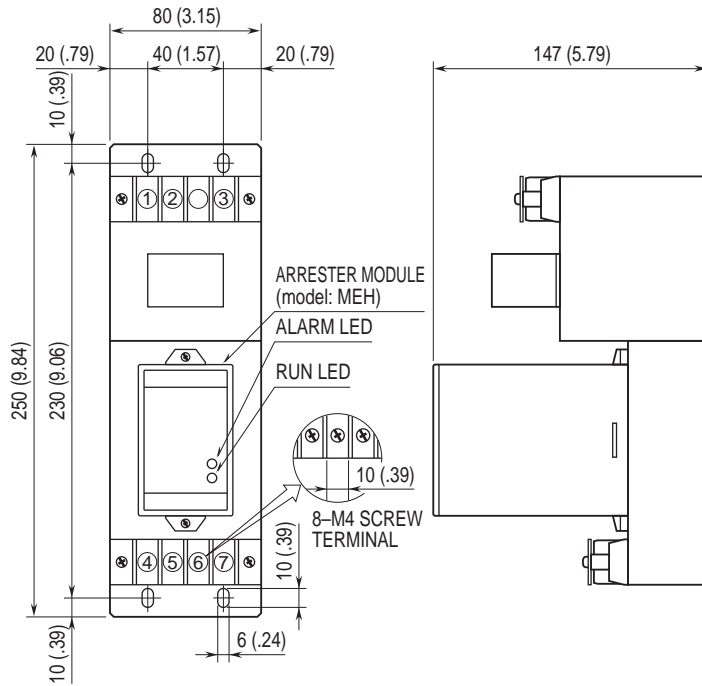

MOUNTING REQUIREMENTS unit: mm (inch)

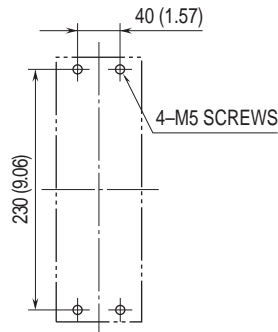

SCHEMATIC CIRCUITRY & CONNECTION DIAGRAM

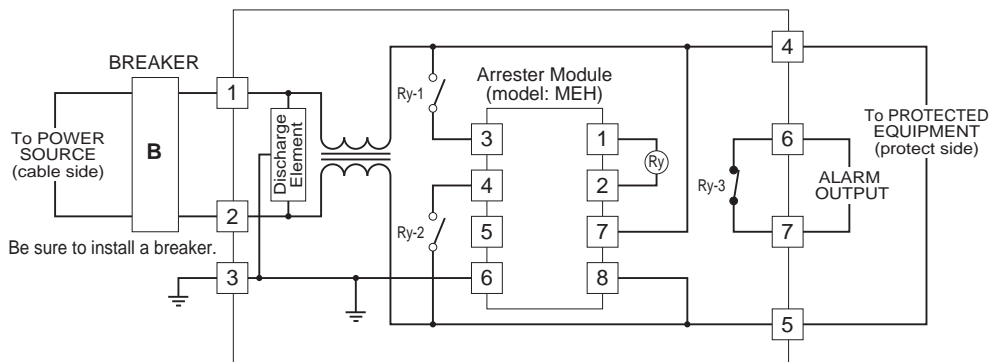

Arrester Module (model: MEH)

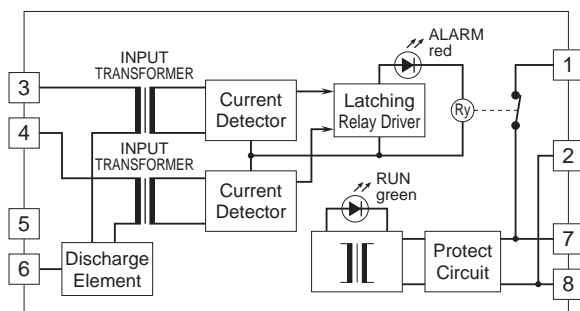

Specifications are subject to change without notice.