

CC02 Ceramic Core Chip Inductors

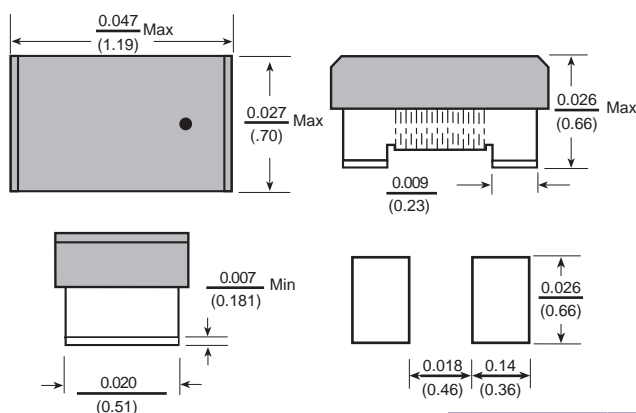

Dimensions: $\frac{\text{Inches}}{\text{(mm)}}$

Features

- 0402 size suitable for pick and place automation
- Low Profile under .66mm
- Ceramic core provide high self resonant frequency.
- High Q values at high frequencies
- Ceramic core also provides excellent thermal and batch consistency

Electrical

Inductance Range: 1nH to 180nH

Tolerance: 10% over entire range

Most values available in tighter tolerances

Test Frequency: At specified frequency with

Test OSC @ 200mV

Operating Temp: -40°C ~ 125°C

Irms: Based on 15°C temperature rise @ 25° Ambient.

Resistance to Soldering Heat

Test Method: Reflow Solder the devide onto PCB

Peak Temp: 260°C ± 5°C for 10 sec.

Solder Composition: Sn/Ag3.0/Cu0.5

Total test time: 6 minutes

Test Equipment

(L/Q): HP4291A / HP16193A

(SRF): HP8753D / Agilent E4991

(RDC): Chen Hwa 502BC

Irms: HP4284A + HP42841A / HP4285A + HP42841A

Physical

Packaging: 4000 pieces per 7 inch reel.

Marking: None

Allied Part Number	Inductance (nH)	Tolerance (%)	Q Min.	Test Freq. (MHz)	SRF Min. (MHz)	DCR Max. (Ω)	Rated Current (mA)
CC02-1N0K-RC	1.0	10	16	250	12700	0.045	1360
CC02-1N2K-RC	1.2	10	10	250	10400	0.140	640
CC02-1N3K-RC	1.3	10	10	250	10400	0.140	640
CC02-1N9K-RC	1.9	10	16	250	11300	0.070	1040
CC02-2N0K-RC	2.0	10	16	250	11100	0.070	1040
CC02-2N2K-RC	2.2	10	19	250	10800	0.070	960
CC02-2N4K-RC	2.4	10	15	250	10500	0.068	790
CC02-2N5K-RC	2.5	10	13	250	10400	0.150	640
CC02-2N7K-RC	2.7	10	16	250	10400	0.120	640
CC02-3N3K-RC	3.3	10	19	250	7000	0.066	840
CC02-3N6K-RC	3.6	10	19	250	6800	0.066	840
CC02-3N9K-RC	3.9	10	19	250	6000	0.066	840
CC02-4N3K-RC	4.3	10	18	250	6000	0.091	700
CC02-4N7K-RC	4.7	10	15	250	4770	0.130	640
CC02-5N1K-RC	5.1	10	20	250	4800	0.083	800
CC02-5N6K-RC	5.6	10	20	250	4800	0.083	760
CC02-5N8K-RC	5.8	10	20	250	4800	0.083	760
CC02-6N2K-RC	6.2	10	20	250	4800	0.083	760
CC02-6N8K-RC	6.8	10	20	250	4800	0.083	680
CC02-7N3K-RC	7.3	10	22	250	4800	0.120	680
CC02-7N5K-RC	7.5	10	22	250	4800	0.100	680
CC02-8N2K-RC	8.2	10	22	250	4400	0.100	680
CC02-8N7K-RC	8.7	10	18	250	4100	0.200	480
CC02-9N0K-RC	9.0	10	22	250	4160	0.100	680
CC02-9N1K-RC	9.1	10	22	250	4160	0.100	680
CC02-9N5K-RC	9.5	10	18	250	4000	0.200	480
CC02-10NK-RC	10	10	21	250	3900	0.200	480
CC02-11NK-RC	11	10	24	250	3680	0.120	640
CC02-12NK-RC	12	10	24	250	3600	0.120	640
CC02-13NK-RC	13	10	24	250	3450	0.210	440
CC02-15NK-RC	15	10	24	250	3280	0.170	560
CC02-16NK-RC	16	10	24	250	3100	0.220	560
CC02-18NK-RC	18	10	25	250	3100	0.230	420
CC02-19NK-RC	19	10	24	250	3040	0.200	480
CC02-20NK-RC	20	10	25	250	3000	0.250	420
CC02-22NK-RC	22	10	25	250	2800	0.300	400
CC02-23NK-RC	23	10	22	250	2720	0.300	400
CC02-24NK-RC	24	10	25	250	2700	0.300	400
CC02-27NK-RC	27	10	24	250	2480	0.300	400
CC02-30NK-RC	30	10	25	250	2350	0.350	400
CC02-33NK-RC	33	10	24	250	2350	0.400	400
CC02-36NK-RC	36	10	24	250	2320	0.440	320
CC02-39NK-RC	39	10	25	250	2100	0.550	200
CC02-40NK-RC	40	10	24	250	2240	0.440	320
CC02-43NK-RC	43	10	25	250	2030	0.810	100
CC02-47NK-RC	47	10	20	250	2100	0.830	150
CC02-51NK-RC	51	10	25	250	1750	0.820	100
CC02-56NK-RC	56	10	22	250	1760	0.970	100

Also available in 5% = J, 2% = G, 0.2nH = C, 0.1nH = B
All specifications subject to change without notice.

CC02 Ceramic Core Chip Inductors



Features

- 0402 size suitable for pick and place automation
- Low Profile under .66mm
- Ceramic core provide high self resonant frequency.
- High Q values at high frequencies
- Ceramic core also provides excellent thermal and batch consistency

Allied Part Number	Inductance (nH)	Tolerance (%)	Q Min.	Test Freq. (MHz)	SRF Min. (MHz)	DCR Max. (Ω)	Rated Current (mA)
CC02-68NK-RC	68	10	22	250	1620	1.12	100
CC02-72NK-RC	72	10	20	250	1260	2.00	30
CC02-82NK-RC	82	10	20	250	1260	1.55	50
CC02-R10K-RC	100	10	20	250	1160	2.00	30
CC02-R18K-RC	180	10	8	100	700	2.70	50

Also available in 5% = J, 2% = G, 0.2nH = C, 0.1nH = B
All specifications subject to change without notice.

Electrical

Inductance Range: 1nH to 180nH

Tolerance: 10% over entire range

Most values available in tighter tolerances

Test Frequency: At specified frequency with

Test OSC @ 200mV

Operating Temp: -40°C ~ 125°C

Irms: Based on 15°C temperature rise @

25° Ambient.

Resistance to Soldering Heat

Test Method: Reflow Solder the device onto PCB

Peak Temp: 260°C ± 5°C for 10 sec.

Solder Composition: Sn/Ag3.0/Cu0.5

Total test time: 6 minutes

Test Equipment

(L/Q): HP4291A / HP16193A

(SRF): HP8753D / Agilent E4991

(RDC): Chen Hwa 502BC

Irms: HP4284A + HP42841A / HP4285A + HP42841A

Physical

Packaging: 4000 pieces per 7 inch reel.

Marking: None