

## Remote I/O R3 Series

### CC-Link INTERFACE MODULE

(CC-Link Ver.1.10; for 32-point analog signals)

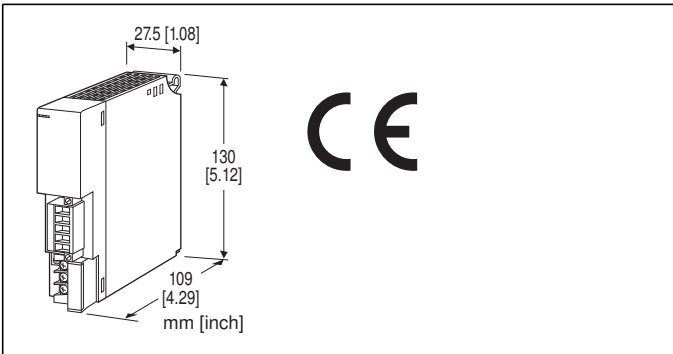

### MODEL: R3-NC2-[1][2]

#### ORDERING INFORMATION

- Code number: R3-NC2-[1][2]
- Specify a code from below for each of [1] and [2].  
(e.g. R3-NC2-R/CE/Q)
- Specify the specification for option code /Q  
(e.g. /C01/SET)

#### [1] POWER INPUT

**N:** No power supply

##### AC Power

**K3:** 100 - 120 V AC

(Operational voltage range 85 - 132 V, 47 - 66 Hz) \*  
(CE not available)

**L3:** 200 - 240 V AC

(Operational voltage range 170 - 264 V, 47 - 66 Hz) \*  
(CE not available)

##### DC Power

**R:** 24 V DC

(Operational voltage range 24 V  $\pm$ 10 %, ripple 10 %p-p max.) \*

\* Not selectable for use with independent power modules or network modules with the internal power input options.

#### [2] OPTIONS (multiple selections)

##### Standards & Approvals

**blank:** Without CE

**/CE:** CE marking

##### Other Options

**blank:** none

**/Q:** Option other than the above (specify the specification)

#### SPECIFICATIONS OF OPTION: Q (multiple selections)

##### COATING (For the detail, refer to M-System's web site.)

**/C01:** Silicone coating

**/C02:** Polyurethane coating

**/C03:** Rubber coating

##### EX-FACTORY SETTING

**/SET:** Preset according to the Ordering Information Sheet  
(No. ESU-8355)

#### PACKAGE INCLUDES...

- Terminating resistor (110  $\Omega$ , 0.5 W)

#### GENERAL SPECIFICATIONS

##### Connection

**CC-Link:** Euro type connector terminal

(applicable wire size: 0.2 to 2.5 mm<sup>2</sup>, stripped length 7 mm)

**Internal bus:** Via the Installation Base

(model: R3-BSx)

**Internal power:** Via the Installation Base (model: R3-BSx)

**Power input, RUN contact output:** M3 separable screw terminal (torque 0.5 N·m)

**Screw terminal:** Nickel-plated steel

**Isolation:** CC-Link to internal bus or internal power to power supply to RUN contact output to FG

**Input error data setting:** Input value setting at input module error with side DIP SW

**Dual communication setting:** Set with the side DIP switch

**Data allocation setting:** Set with the side DIP switch

**RUN indicator:** Bi-color (green/red) LED; Green ON in normal communication; Red ON when receiving data (Function selected with DIP SW)

**ERR indicator:** Bi-color (green/red) LED;

Green ON or blinking at communication error (OFF with cable disconnection, blinking in setting error); Red ON at transmitting data (Function selected with DIP SW)

##### ■ RUN CONTACT OUTPUT

**RUN contact:** Turns ON while the green RUN LED is ON (CC-Link in normal communication).

**Rated load:** 250 V AC @ 0.5 A ( $\cos \phi = 1$ )

30 V DC @ 0.5 A (resistive load)

(Less than 50 V AC to conform with EU Directive)

**Maximum switching voltage:** 250 V AC or 30 V DC

**Maximum switching power:** 250 VA or 150 W

**Minimum load:** 1 V DC @ 1 mA

**Mechanical life:**  $2 \times 10^7$  cycles (300 cycles/min.)

When driving an inductive load, external contact protection and noise quenching recommended.

## CC-Link COMMUNICATION

**CC-Link:** Conforms to Version 1.10

**Station No. setting:** Rotary switch; 1 - 64

**Baud rate setting:** Rotary switch

156kbps, 625kbps, 2.5Mbps, 5Mbps, 10Mbps

**Station type:** Remote device station

**Required nodes:** 8 (4 stations × 2)

(128 I/O points, 16 words) × 2

(This unit incorporates two ASICs, each requires 4 stations (128 I/O points, 16 words), which are equivalent to two 4-station remote devices.)

**Transmission cable:** Approved for CC-Link

## INSTALLATION

**Power consumption**

•AC: Approx. 20 VA

•DC: Approx. 12 W

**Current consumption (no power supply):** 130 mA

**Output current (power supply):** 250 mA continuous at 20 V DC; 400 mA for 10 minutes

**Operating temperature:** -10 to +55°C (14 to 131°F)

**Operating humidity:** 30 to 90 %RH (non-condensing)

**Atmosphere:** No corrosive gas or heavy dust

**Mounting:** Installation Base (model: R3-BSx)

**Weight:** 200 g (0.44 lb)

## PERFORMANCE

**Insulation resistance:** ≥ 100 MΩ with 500 V DC

**Dielectric strength:** 1500 V AC @ 1 minute (CC-Link to internal bus or internal power to power input to RUN contact output to FG)

## STANDARDS & APPROVALS

**EU conformity:**

EMC Directive

EMI EN 61000-6-4

EMS EN 61000-6-2

RoHS Directive

## EXTERNAL VIEW

### FRONT VIEW

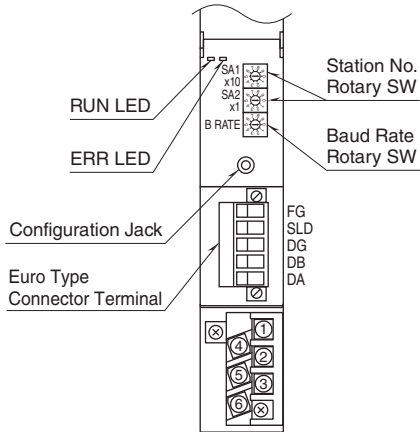

### SIDE VIEW

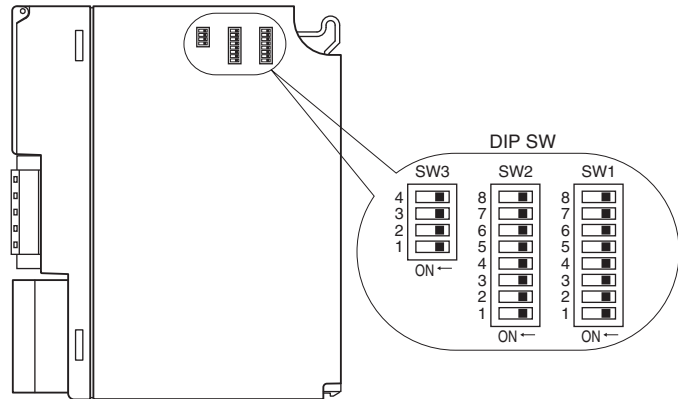

## COMMUNICATION CABLE CONNECTIONS

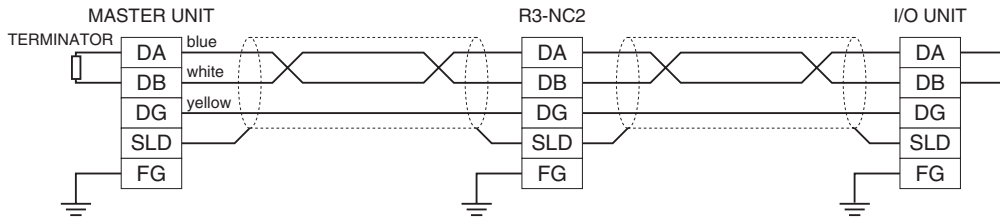

## TRANSMISSION DATA DESCRIPTIONS

The DIP SW located at the side of the module specifies each I/O module's data allocation (occupied data area).

For example, when the data areas are assigned as shown below:

Module 1	4
Module 2	4
Module 3	4
Module 4	4
Module 5	4
Module 6	1
Module 7	1
Module 8	1

Then the I/O data are assigned as in the figures below:

### ■ OUTPUT DATA

The figure below shows the allocation of the data sent from the network module to the master.

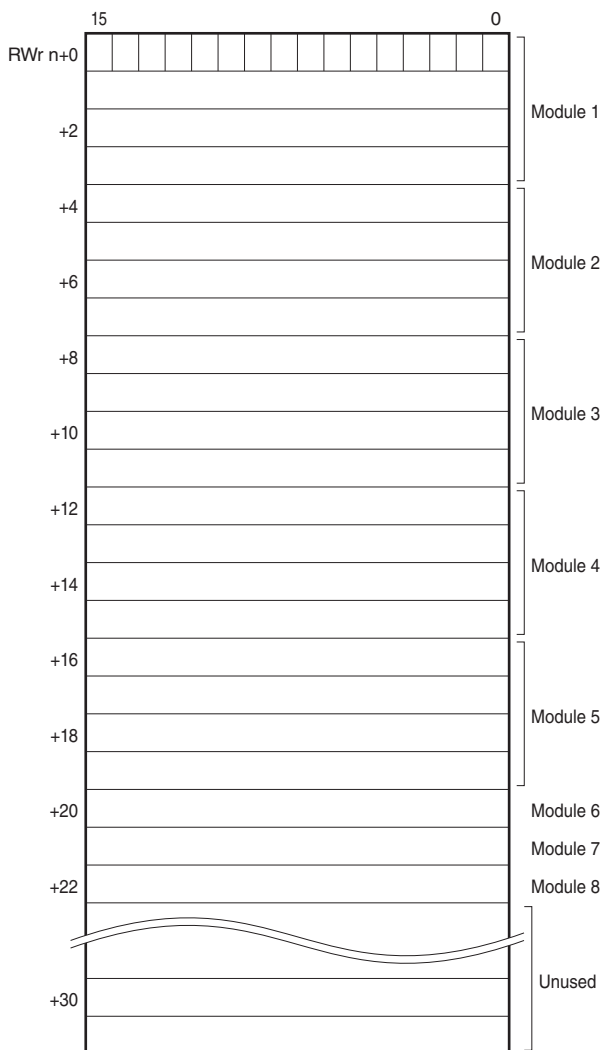

### ■ INPUT DATA

The figure below shows the allocation of the data sent from the master to the network module.

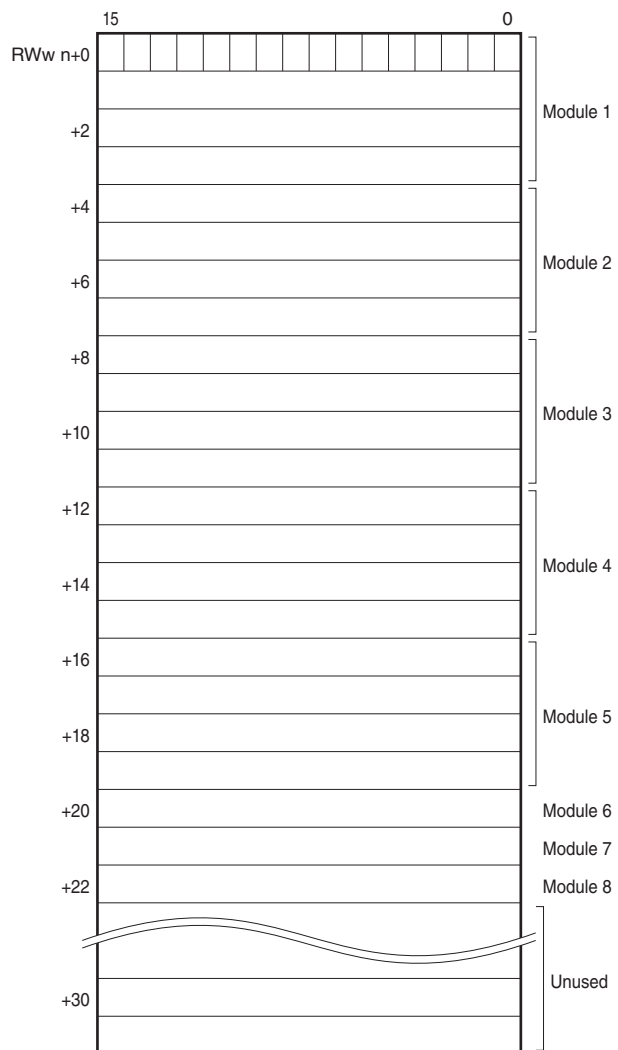

Thirty-two (32) data areas are available to this unit. Total data areas occupied by I/O modules must be within this limitation.

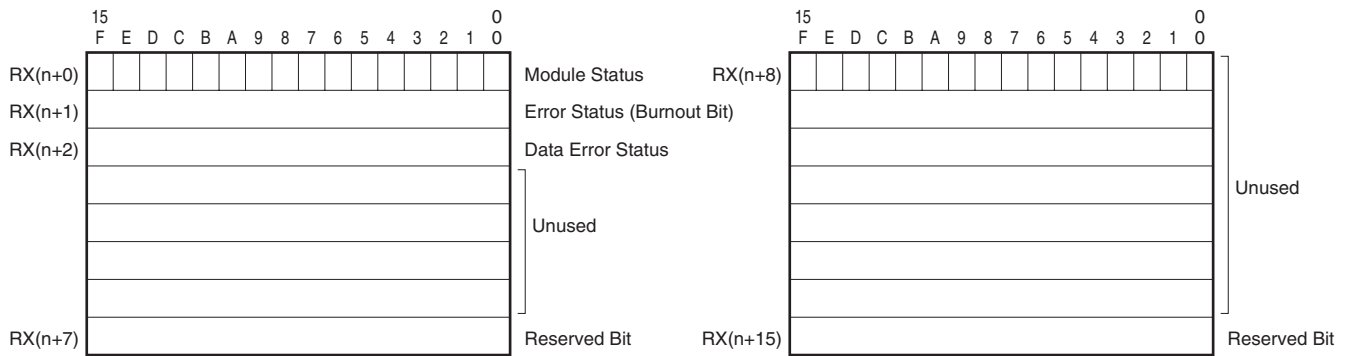

- **Module Status**

RX(n+0)0 through RX(n+0)F indicate whether individual I/O modules are mounted or not. The bit corresponding to the mounted slot turns to “1,” and the unmounted slot to “0.”

- **Error Status**

RX(n+1)0 through RX(n+1)F indicate error status for each module as described below. The bit corresponding to such module turns to “1.”

- R3-TSx, R3-RSx, R3-US4: Input burnout
- R3-DA16A: Power input in error or disconnected
- R3-YSx: Output current error (e.g. load unconnected)
- R3-PC16A: External power supply in error or disconnected

- **Data Error Status**

RX(n+2)0 through RX(n+2)F indicate overrange (R3-US4: out of -10% to +110%; the other types: out of -15% to +115%) status for each module. The bit corresponding to such module turns to “1.”

- RX(n+3) through RX(n+6) are unused.
- RX(n+8) through RX(n+14) are unused.

- RX(n+7)0 through RX(n+7)7 are reserved for future use. RX(n+7)B is assigned to Ready signal for ASIC 0, which is turned to “1” when the network module is in normal conditions. RX(n+7)8 through RX(n+7)A, RX(n+7)C through RX(n+7)F are not used.

RX(n+15)0 through RX(n+15)7 are reserved for future use. RX(n+15)B is assigned to Ready signal for ASIC 1, which is turned to “1” when the network module is in normal conditions. RX(n+15)8 through RX(n+15)A, RX(n+15)C through RX(n+15)F are not used.

RX(n+0) 0, RX(n+1) 0, RX(n+2) 0	Module 1
RX(n+0) 1, RX(n+1) 1, RX(n+2) 1	Module 2
RX(n+0) 2, RX(n+1) 2, RX(n+2) 2	Module 3
⋮	⋮
RX(n+0) F, RX(n+1) F, RX(n+2) F	Module 16

## MODULE STATUS, ERROR STATUS, DATA ERROR STATUS

Shows each module's availability and error status.

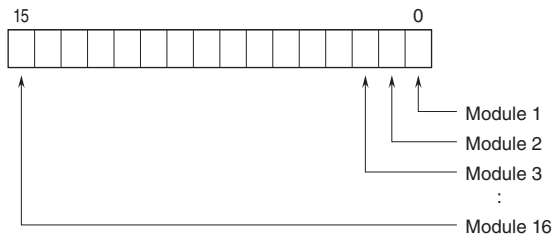

## I/O DATA DESCRIPTIONS

The data allocations for typical I/O modules are shown below.

Refer to the manual for each module for detailed data allocations.

### ■ ANALOG DATA (16-bit data, models: R3-SV4, YV4, DS4, YS4, US4, etc.)

16-bit binary data.

Basically, 0 to 100% of the selected I/O range is converted into 0 to 10000 (binary).

-15 to 0 % is a negative range represented in 2's complement.

In case of R3-US4, -10 to 0% is a negative range represented in 2's complement.



### ■ TEMPERATURE DATA (16-bit data, models: R3-RS4, TS4, US4, etc.)

16-bit binary data.

With °C temperature unit, raw data is multiplied by 10. For example, 25.5°C is converted into 255.

With °F temperature unit, the integer section of raw data is directly converted into the data.

For example, 135.4°F is converted into 135.

Minus temperature is converted into negative values, represented in 2's complements.



### ■ ANALOG DATA (16-bit data, models: R3-CT4A, CT4B, etc.)

16-bit binary data.

Integer obtained by multiplying unit value (A) by 100.

In case of CLSE-R5, integer obtained by multiplying unit value (A) by 1000.



### ■ ACCUMULATED COUNT DATA (32-bit data, models: R3-PA2, PA4A, WT1, WT4, etc.)

32-bit binary data is used for accumulated counts and encoder positions.

Lower 16 bits are allocated from the lowest address to higher ones, higher 16 bits in turn.

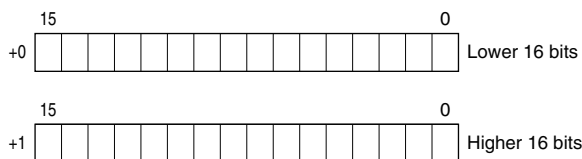

## ■ BCD DATA (32-bit data, models: R3-BA32A, BC32A, etc.)

32-bit binary data is used for BCD.

Lower 16 bits are allocated from the lowest address to higher ones, higher 16 bits in turn.

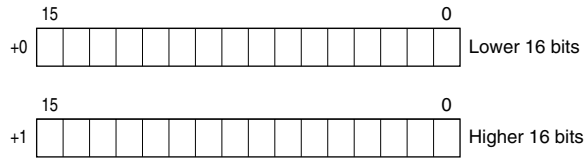

## ■ 16-POINT DISCRETE DATA (models: R3-DA16, DC16, etc.)

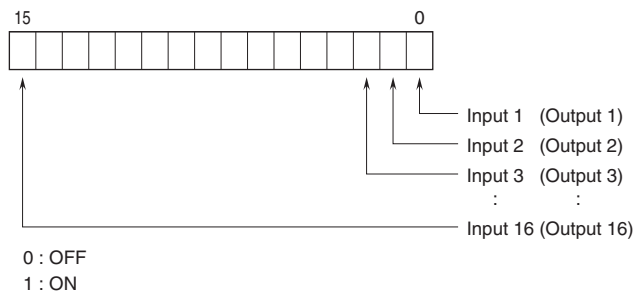

## EXTERNAL DIMENSIONS & TERMINAL ASSIGNMENTS unit: mm [inch]

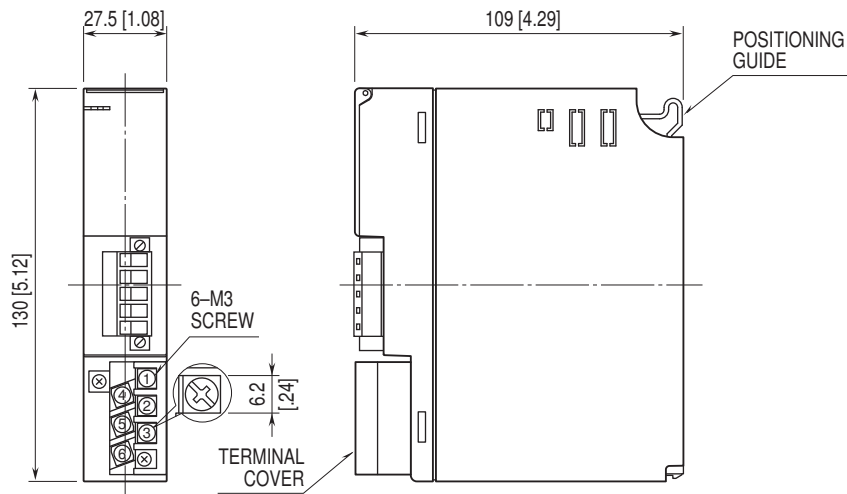

## SCHEMATIC CIRCUITRY & CONNECTION DIAGRAM

Note: In order to improve EMC performance, bond the FG terminal to ground.

Caution: FG terminal is NOT a protective conductor terminal.

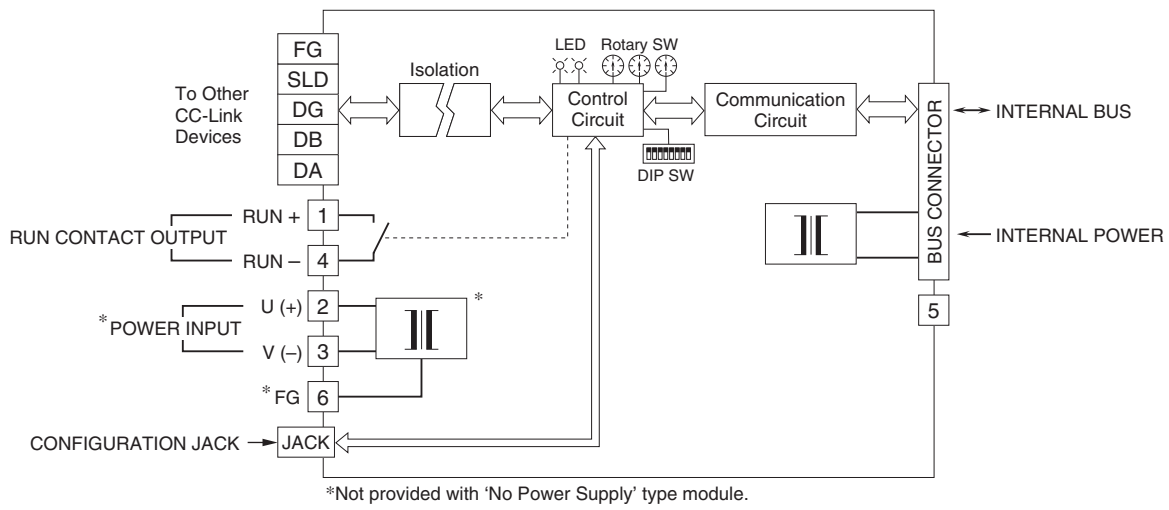

Specifications are subject to change without notice.