

### DESCRIPTION:

The 413 series is cylindrical type in 3mm diameter package.  
The semi-conductor materials used are:  
GaP for (413HD, 413GD/GT)  
GaAsP/GaP for (413RHD/RHT, 413YD/YT and 413SD/ST)

### ABSOLUTE MAXIMUM RATINGS: (Ta=25°C)

Reverse Voltage	5 Volt
Reverse Current (Vr =5V)	100μA
Operating Temperature Range	-40°C To 85°C
Storage Temperature Range	-40°C To 100°C
Lead Soldering Temperature (1.6mm (1/16)From Body)	260°C For 5 Seconds

NOTES : 1. All dimensions are in millimeters.  
2. Lead spacing is measured where the leads emerge from the package.  
3. Protuded resin under flange is 1.5 mm (0.059") Max.  
4. Specifications are subject to change without notice.

### PACKAGE DIMENSIONS

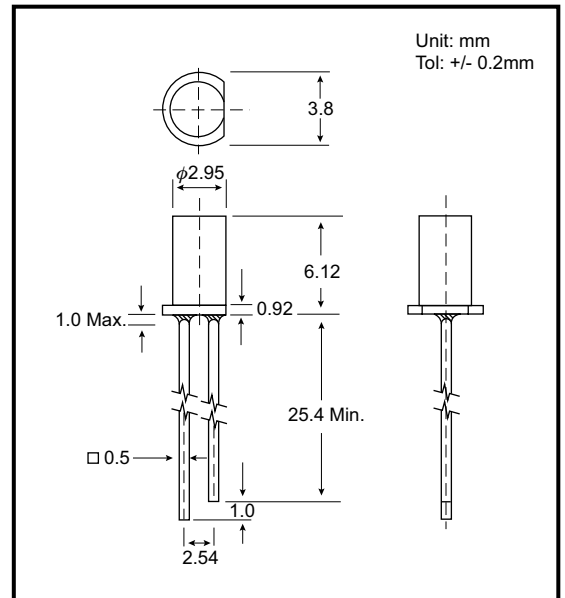

### PART NO. SELECTION AND APPLICATION INFORMATION (RATINGS AT 25°C AMBIENT)

Part No.	Emitted Color	Lens Color	Peak Wavelength λp (nm)	Vf (v)		Rec. If (mA).	Iv (mcd)		View Angle 2θ1/2(Deg)
				Min	Max		Min	Typ.	
GB-413HD	Red	Red Diffused	697	1.7	2.6	5-10	0.3	0.5	120
GB-413RHD	Bright Red	Red Diffused	660	1.7	2.6	10-20	0.4	1.2	120
GB-413GD	Green	Green Diffused	565	1.7	2.6	10-20	0.4	1.2	120
GB-413YD	Yellow	Yellow Diffused	585	1.7	2.6	10-20	0.4	1.2	120
GB-413SD	Orange	Orange Diffused	610	1.7	2.6	10-20	0.4	1.2	120
GB-413RHT	Bright Red	Red Trans.	660	1.7	2.6	10-20	0.6	2.0	100
GB-413GT	Green	Green Trans.	565	1.7	2.6	10-20	0.6	2.0	100
GB-413YT	Yellow	Yellow Trans.	585	1.7	2.6	10-20	0.6	2.0	100
GB-413ST	Orange	Orange Trans.	610	1.7	2.6	10-20	0.6	2.0	100

### TESTING CONDITION FOR EACH PARAMETER :

PARAMETER:	SYMBOL	UNIT	TEST CONDITION
REVERSE VOLTAGE	Vr	VOLT	Vr = 5.0 Volt
REVERSE CURRENT	Ir	μA	If = 20mA
FORWARD VOLTAGE	Vf	VOLT	If = 20mA
LUMINOUS INTENSITY	Iv	MCD	If = 20mA
VIEWING ANGLE	2θ1/2	DEGREE	
RECOMMENDED OPERATING CURRENT	If (Rec)	mA	

