

50Ω DC to 45 GHz

### The Big Deal

- Excellent Return Loss, 20 dB typ.
- Wide bandwidth, DC - 45 GHz
- Small Size, 2 mm x 2 mm



CASE STYLE: MC1630-1

### Product Overview

EQY series of absorptive Gain Equalizers are fabricated using highly repetitive GaAs IPD\* MMIC process incorporating resistors, capacitors and inductors having negative insertion loss slope. EQYs are available with nominal attenuation slope of 3,4,5,6,7,8,9 & 10 dB. They are packaged in tiny 2 x 2 mm 6-Lead MCLP™ package.

### Key Features

Feature	Advantages
Negative Insertion Loss Slope vs. Frequency	Useful for compensating negative gain slope of amplifiers, receivers, transmitters to achieve flat gain versus frequency.
Wide range of values 3,4,5,6,7,8,9,10 dB	Enables circuit designer to change nominal insertion loss values without motherboard redesign making the EQY series ideal for select at test application.
Wideband operation, DC to 45 GHz	Supports a wide array of applications including wireless cellular, microwave communications, satellite, defense and aerospace, medical broadband and optic applications.
Excellent Power Handling Capability up to 30 dBm	Enables its use at the output of a variety of amplifiers
Small Size and simple to use (2 mm x 2 mm)	As a single chip solution, the EQY series occupies less board space than a lumped or distributed element approach, minimizes component count and ensures repeatable performance over wide frequency range.

\*GaAs IPD (Gallium Arsenide Integrated Passive Device)

Microwave

# Gain Equalizer

## EQY-4-453+

50Ω 4dB DC to 45 GHz

### Product Features

- 4.5 dB Slope from DC to 45 GHz
- Small Package 2 x 2 mm MCLP
- Excellent Return Loss, 20 dB typ.
- Patent pending

### Typical Applications

- Cellular Infrastructure
- 5G
- Wideband Communications
- Test Instrumentation
- Defense

### General Description

EQY-4-453+ is an absorptive Gain Equalizer fabricated using highly repetitive GaAs IPD MMIC process incorporating resistors, capacitors and inductors having negative insertion loss slope. EQY-4-453+ has a nominal attenuation slope of 4.5 dB and is packaged in tiny 2 x 2 mm, 6-Lead MCLP™ package.



Generic photo used for illustration purposes only

CASE STYLE: MC1630-1

#### +RoHS Compliant

The +Suffix identifies RoHS Compliance. See our web site for RoHS Compliance methodologies and qualifications

### Simplified Schematic & Pad Description

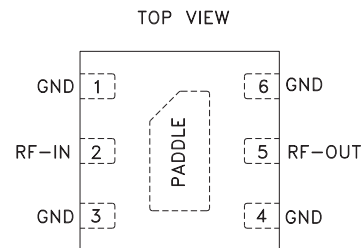
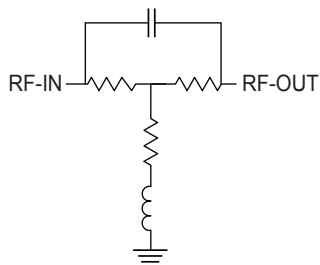

Function	Pad Number	Description
RF-IN	2	RF-Input pad
RF-OUT	5	RF-Output pad
GND	1,3,4,6 & Paddle	Ground

**Electrical Specifications<sup>1</sup> at 25°C, 50Ω, unless otherwise noted.**

Parameter	Condition (GHz)	Min.	Typ.	Max.	Units
Frequency Range		DC		45	GHz
Insertion Loss	0.01	5.4	5.6	5.9	dB
	10	5.0	5.3	5.6	
	20	—	4.3	—	
	30	2.3	2.9	3.3	
	40	—	1.5	—	
VSWR	45	—	1.1	—	:1
	0.01 - 10	—	1.16	—	
	10 - 20	—	1.16	—	
	20 - 30	—	1.24	—	
	30 - 40	—	1.34	—	
	40 - 45	—	1.46	—	

1. Measured on Mini-Circuits Characterization Test Board TB-EQY-4-453+. See Characterization Test Circuit (Fig. 1)

**Absolute Maximum Ratings<sup>2</sup>**

Operating Case Temperature	-55°C to 105°C
Storage Temperature	-65°C to 150°C
RF Input Power <sup>3</sup>	29 dBm

2. Permanent damage may occur if any of these limits are exceeded.

3. Derates linearly to 25 dBm at 105°C

**Characterization Test Circuit**

Fig 1. Block Diagram of Test Circuit used for characterization. Test Board TB-EQY-4-453+  
Conditions: Attenuation & Return Loss Pin=0 dBm

**Product Marking**

Marking may contain other features or characters for internal lot control

Additional Detailed Technical Information	
<i>additional information is available on our dash board. To access this information <a href="#">click here</a></i>	
<b>Performance Data</b>	Data Table
	Swept Graphs
<b>Case Style</b>	MC1630-1 <i>Plastic package, Lead finish: Matte-tin</i>
<b>Tape &amp; Reel</b> Standard quantities available on reel	F66 <i>7" reels with 20, 50, 100, 200, 500, 1K or 2K devices</i>
<b>Suggested Layout for PCB Design</b>	PL-663
<b>Evaluation Board</b>	TB-EQY-4-453+ & TB-EQY-4-453C+
<b>Environmental Ratings</b>	ENV08T1

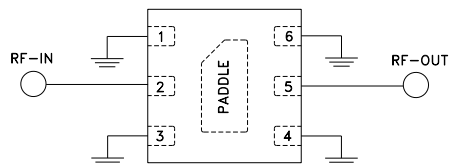
### ESD Rating

Human Body Model (HBM): Class 2 (Pass 2000V) in accordance with ANSI/ESD STM 5.1 - 2001 Machine.

### MSL Test Flow Chart

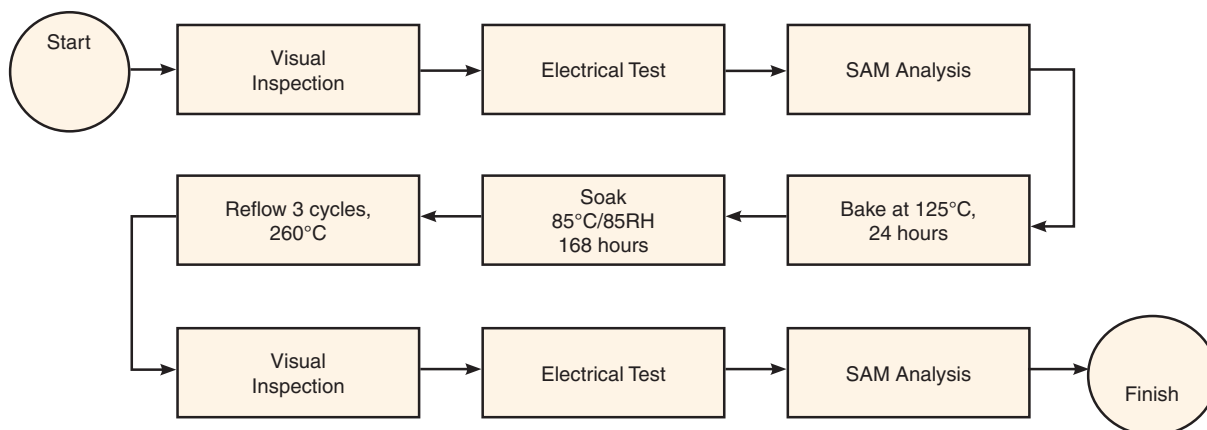

### Additional Notes

- Performance and quality attributes and conditions not expressly stated in this specification document are intended to be excluded and do not form a part of this specification document.
- Electrical specifications and performance data contained in this specification document are based on Mini-Circuit's applicable established test performance criteria and measurement instructions.
- The parts covered by this specification document are subject to Mini-Circuits standard limited warranty and terms and conditions (collectively, "Standard Terms"); Purchasers of this part are entitled to the rights and benefits contained therein. For a full statement of the Standard Terms and the exclusive rights and remedies thereunder, please visit Mini-Circuits' website at [www.minicircuits.com/MCLStore/terms.jsp](http://www.minicircuits.com/MCLStore/terms.jsp)

*Typical Performance Data*

FREQ.  (MHz)	INSERTION LOSS			INPUT VSWR			OUTPUT VSWR		
	(dB)			(:1)			(:1)		
	@-55°C	@25°C	@+105°C	@-55°C	@25°C	@+105°C	@-55°C	@25°C	@+105°C
10	5.64	5.64	5.65	1.14	1.15	1.15	1.15	1.15	1.16
20	5.63	5.63	5.65	1.10	1.10	1.10	1.10	1.11	1.11
30	5.64	5.64	5.65	1.08	1.09	1.09	1.09	1.09	1.09
40	5.64	5.64	5.65	1.08	1.08	1.09	1.08	1.09	1.09
50	5.63	5.64	5.65	1.08	1.08	1.08	1.08	1.08	1.09
60	5.64	5.64	5.65	1.07	1.08	1.08	1.08	1.08	1.09
70	5.64	5.64	5.65	1.07	1.08	1.08	1.08	1.08	1.08
80	5.64	5.64	5.65	1.07	1.08	1.08	1.07	1.08	1.08
90	5.64	5.64	5.65	1.07	1.08	1.08	1.07	1.08	1.08
100	5.64	5.64	5.65	1.07	1.08	1.08	1.07	1.08	1.08
200	5.64	5.65	5.65	1.07	1.08	1.08	1.07	1.08	1.08
400	5.64	5.65	5.67	1.07	1.08	1.08	1.07	1.08	1.08
600	5.65	5.66	5.68	1.08	1.08	1.08	1.07	1.08	1.08
800	5.65	5.66	5.68	1.08	1.09	1.09	1.08	1.08	1.09
1000	5.66	5.66	5.69	1.09	1.09	1.09	1.09	1.09	1.09
2000	5.67	5.69	5.70	1.14	1.14	1.15	1.13	1.13	1.13
3000	5.67	5.67	5.70	1.17	1.17	1.20	1.16	1.16	1.17
4000	5.64	5.64	5.68	1.18	1.19	1.21	1.19	1.19	1.19
5000	5.60	5.61	5.65	1.17	1.17	1.17	1.21	1.20	1.21
6000	5.57	5.59	5.63	1.18	1.18	1.16	1.24	1.24	1.24
7000	5.57	5.58	5.63	1.23	1.22	1.20	1.30	1.29	1.29
8000	5.52	5.54	5.60	1.29	1.28	1.28	1.35	1.34	1.34
9000	5.41	5.45	5.50	1.31	1.30	1.32	1.35	1.34	1.35
10000	5.26	5.31	5.35	1.26	1.25	1.27	1.29	1.29	1.26
11000	5.13	5.18	5.23	1.17	1.16	1.16	1.19	1.18	1.16
12000	5.03	5.08	5.14	1.10	1.10	1.07	1.12	1.11	1.10
13000	4.94	4.99	5.06	1.09	1.07	1.02	1.11	1.08	1.06
14000	4.80	4.86	4.94	1.03	1.04	1.07	1.08	1.05	1.03
15000	4.68	4.76	4.85	1.13	1.13	1.20	1.16	1.14	1.16
16000	4.64	4.71	4.82	1.28	1.28	1.31	1.30	1.27	1.28
17000	4.62	4.67	4.76	1.39	1.37	1.32	1.38	1.34	1.32
18000	4.50	4.58	4.65	1.40	1.38	1.29	1.36	1.34	1.30
19000	4.33	4.42	4.54	1.37	1.35	1.32	1.29	1.28	1.26
20000	4.14	4.25	4.43	1.34	1.32	1.40	1.22	1.22	1.21
21000	3.99	4.08	4.28	1.33	1.31	1.41	1.18	1.18	1.18
22000	3.85	3.94	4.09	1.31	1.31	1.32	1.15	1.16	1.18
23000	3.70	3.79	3.91	1.29	1.30	1.18	1.14	1.15	1.19
24000	3.52	3.61	3.79	1.27	1.28	1.24	1.13	1.15	1.18
25000	3.35	3.43	3.66	1.24	1.25	1.36	1.11	1.13	1.14
26000	3.15	3.28	3.45	1.23	1.23	1.37	1.08	1.09	1.13
27000	2.98	3.16	3.22	1.23	1.24	1.19	1.07	1.07	1.06
28000	2.86	3.06	3.13	1.27	1.28	1.17	1.13	1.11	1.17
29000	2.75	2.93	3.12	1.33	1.32	1.40	1.17	1.15	1.22
30000	2.62	2.80	3.03	1.37	1.36	1.54	1.20	1.19	1.17
31000	2.50	2.69	2.89	1.46	1.42	1.60	1.29	1.27	1.31
32000	2.35	2.56	2.67	1.56	1.50	1.51	1.43	1.38	1.42
33000	2.14	2.39	2.44	1.58	1.52	1.39	1.49	1.45	1.42
34000	1.93	2.15	2.28	1.48	1.44	1.36	1.42	1.40	1.38
35000	1.74	1.95	2.11	1.33	1.31	1.34	1.30	1.29	1.29
36000	1.63	1.82	1.96	1.22	1.22	1.25	1.20	1.19	1.16
37000	1.57	1.74	1.90	1.17	1.22	1.19	1.13	1.14	1.13
38000	1.56	1.72	1.92	1.17	1.26	1.23	1.11	1.15	1.18
39000	1.49	1.66	1.89	1.25	1.32	1.34	1.16	1.20	1.25
40000	1.44	1.60	1.86	1.38	1.40	1.47	1.28	1.26	1.30
41000	1.42	1.58	1.83	1.55	1.49	1.59	1.46	1.39	1.45
42000	1.39	1.54	1.69	1.69	1.59	1.57	1.62	1.53	1.54
43000	1.31	1.47	1.50	1.83	1.71	1.48	1.75	1.67	1.52
44000	1.11	1.36	1.43	1.79	1.68	1.48	1.72	1.65	1.49
45000	0.90	1.18	1.47	1.52	1.48	1.52	1.44	1.41	1.43
46000	0.75	1.04	1.40	1.24	1.23	1.40	1.15	1.16	1.28
47000	0.69	1.00	1.29	1.12	1.10	1.18	1.06	1.10	1.14
48000	0.71	1.01	1.30	1.12	1.17	1.08	1.23	1.25	1.21
49000	0.92	1.24	1.61	1.41	1.46	1.50	1.50	1.49	1.51
50000	1.36	1.63	2.09	1.82	1.79	1.90	1.83	1.76	1.77



## Typical Performance Curves

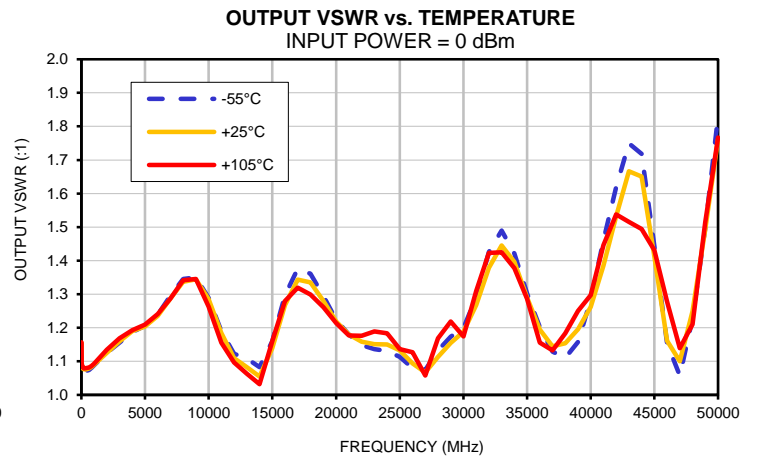
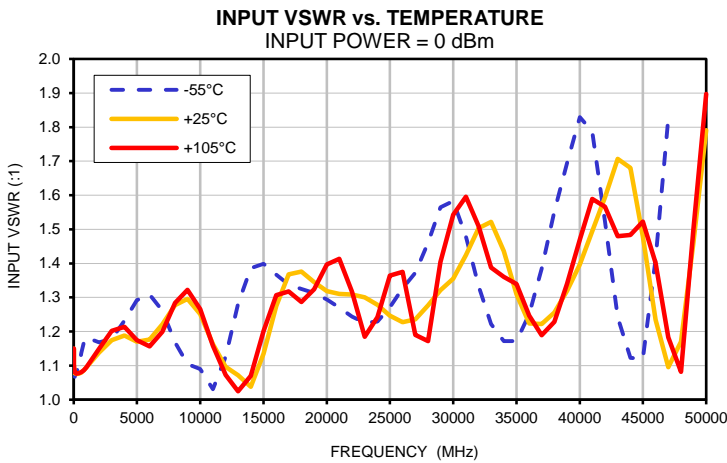
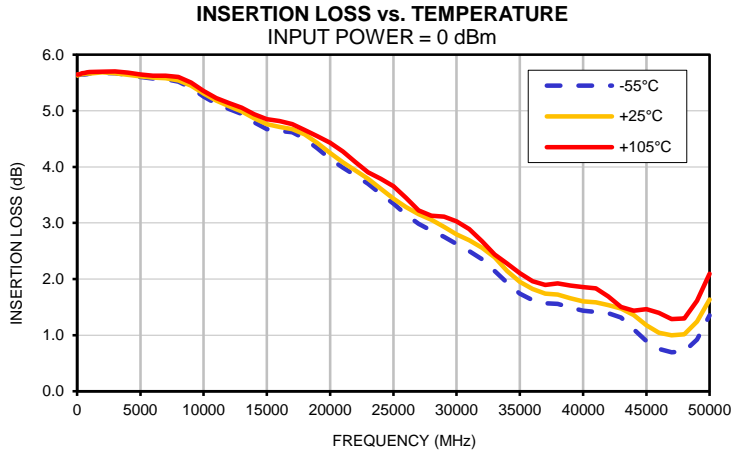

### Outline Dimensions

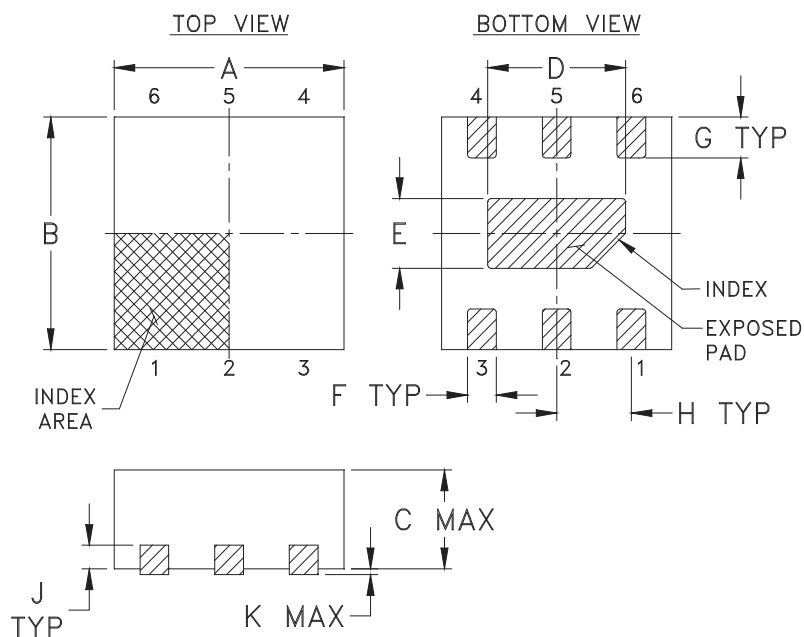

### PCB Land Pattern

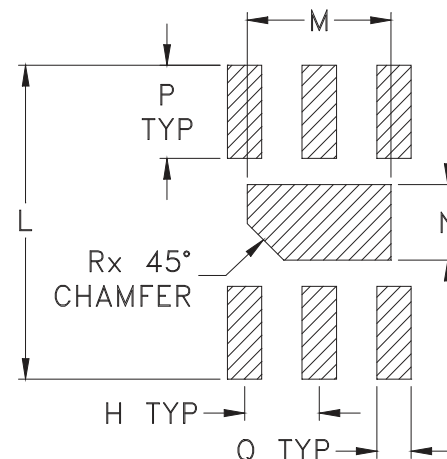

Suggested Layout,  
Tolerance to be within  $\pm .002$

CASE #.	A	B	C	D	E	F	G	H	J	K	L	M	N	P
MC1630-1	.079 (2.00)	.079 (2.00)	.039 (1.00)	.047 (1.20)	.024 (.60)	.010 (.25)	.014 (.35)	.026 (.65)	.008 (.20)	.002 (.05)	.106 (2.70)	.049 (1.25)	.026 (.65)	.031 (.80)

CASE #.	Q	R	WT, GRAM
MC1630-1	.012 (.30)	.012 (.30)	.006

Dimensions are in inches (mm). Tolerances: 2 Pl.  $\pm .01$ ; 3 Pl.  $\pm .005$

#### Notes:

- Case material: Plastic.
- Termination finish:  
For RoHS Case Styles: Tin-Silver over Nickel plated or Matte-Tin plated (See Data sheet).  
All models, (+) suffix.
- Lead #1 identifier shall be located in the cross-hatched area shown.  
Identifier may be either a molded or marked feature.



P.O. Box 350166, Brooklyn, New York 11235-0003 (718) 934-4500 Fax (718) 332-4661 For detailed performance specs & shopping online see Mini-Circuits web site



The Design Engineers Search Engine Provides ACTUAL Data Instantly From MINI-CIRCUITS At: [www.minicircuits.com](http://www.minicircuits.com)

RF/IF MICROWAVE COMPONENTS

# Tape & Reel Packaging TR-F66

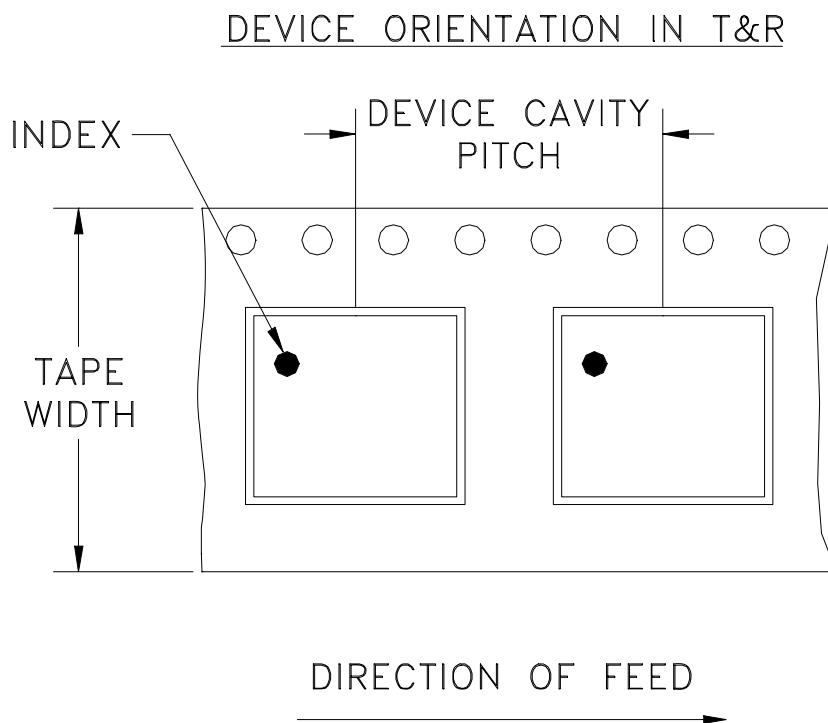

Tape Width, mm	Device Cavity Pitch, mm	Reel Size, inches	Devices per Reel see note	
8	4	7	Small quantity standard	20
				50
				100
				200
				500
		7	Standard	1000, 2000

Note: Please consult individual model data sheet to determine device per reel availability.

Mini-Circuits carrier tape materials provide protection from ESD (Electro-Static Discharge) during handling and transportation. Tapes are static dissipative and comply with industry standards EIA-481/EIA-541.

Go to: [www.minicircuits.com/pages/pdfs/tape.pdf](http://www.minicircuits.com/pages/pdfs/tape.pdf)



INTERNET <http://www.minicircuits.com>

P.O. Box 350166, Brooklyn, New York 11235-0003 (718) 934-4500 Fax (718) 332-4661

Distribution Centers NORTH AMERICA 800-654-7949 • 417-335-5935 • Fax 417-335-5945 • EUROPE 44-1252-832600 • Fax 44-1252-837010

Mini-Circuits ISO 9001 & ISO 14001 Certified



THIRD ANGLE PROJECTION

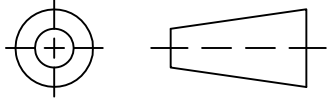

REVISIONS

REV	ECN No.	DESCRIPTION	DATE	DR	AUTH
OR	ECO-001053	NEW RELEASE	12/18/19	GF	IL

SUGGESTED MOUNTING CONFIGURATION  
FOR MC1630-1 CASE STYLE,

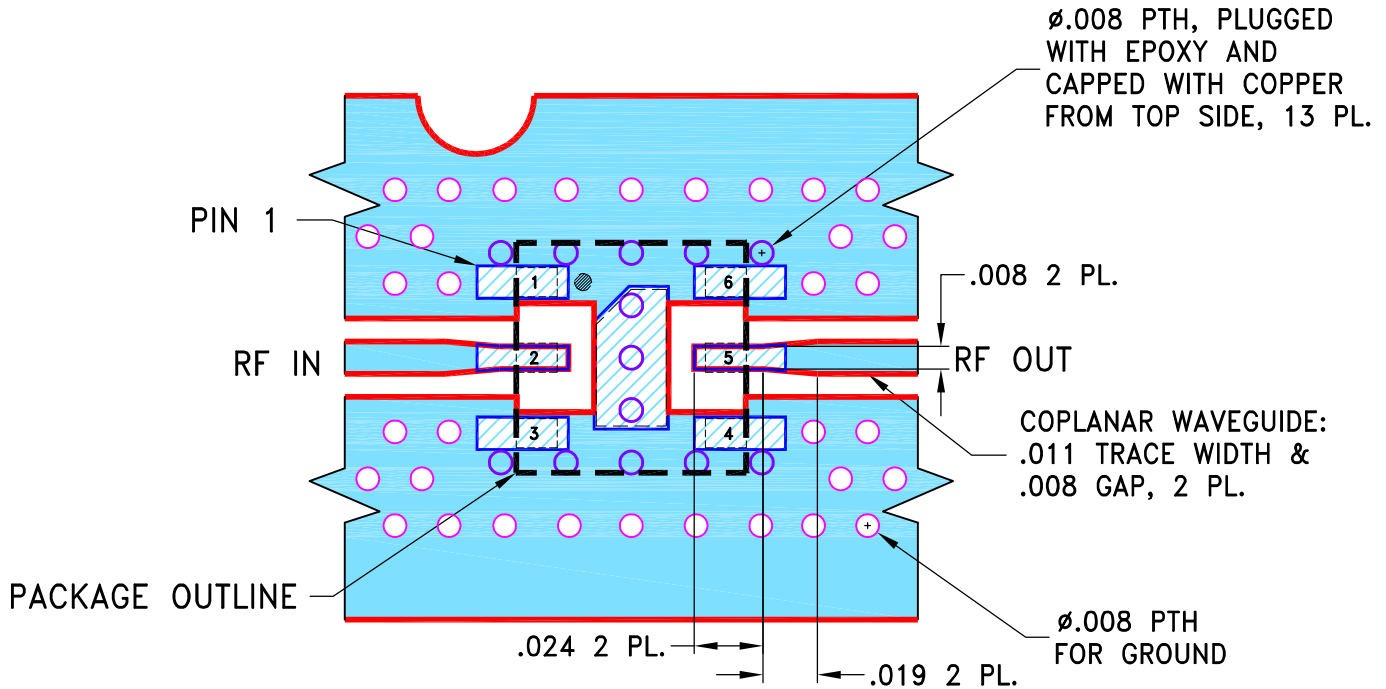

**NOTES:**

1. TRACE WIDTH & GAP PARAMETERS ARE SHOWN FOR ROGERS R04350B WITH DIELECTRIC THICKNESS  $.0066 \pm .001$ . COPPER: 1/2 OZ. EACH SIDE. FOR OTHER MATERIALS TRACE WIDTH & GAP MAY NEED TO BE MODIFIED.
2. UNIT FOOT PRINT IS OPTIMIZED FOR PERFORMANCE AND IS DIFFERENT FROM CASE STYLE MC1630-1 RECOMMENDATIONS.
3. BOTTOM SIDE OF THE PCB IS CONTINUOUS GROUND PLANE.



DENOTES PCB COPPER LAYOUT WITH SMOBC (SOLDER MASK OVER BARE COPPER).

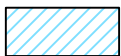

DENOTES COPPER LAND PATTERN FREE OF SOLDER MASK.

UNLESS OTHERWISE SPECIFIED	INITIALS	DATE
DIMENSIONS ARE IN INCHES	DRAWN GF	12/16/19
TOLERANCES ON:	CHECKED IL	12/18/19
2 PL DECIMALS ±	APPROVED IL	12/18/19
3 PL DECIMALS ± .005		
ANGLES ±		
FRACTIONS ±		

**Mini-Circuits®** 13 Neptune Avenue  
Brooklyn NY 11235

PL, MC1630-1, TB-EQY-X-453+  
TB-EQY-X-453C+

Mini-Circuits®  
THIS DOCUMENT AND ITS CONTENTS ARE THE PROPERTY OF MINI-CIRCUITS. EXCEPT FOR USE EXPRESSLY GRANTED, IN WRITING, TO ITS VENDORS, VENDEE AND THE UNITED STATES GOVERNMENT, MINI-CIRCUITS RESERVES ALL PROPRIETARY DESIGN, USE, MANUFACTURING AND REPRODUCTION RIGHTS THERETO. THESE CONTENTS SHALL NOT BE USED, DUPLICATED OR DISCLOSED TO ANY OUTSIDE PARTY, IN WHOLE OR IN PART, WITHOUT WRITTEN PERMISSION OF MINI-CIRCUITS.

ASHEETA1.DWG REV:A DATE:01/12/95

SIZE A	CODE IDENT 15542	DRAWING NO: 98-PL-663	REV: OR
FILE: 98PL663	SCALE: 15:1	SHEET: 1 OF 1	

# Evaluation Board and Circuit

SEE DETAIL "A"

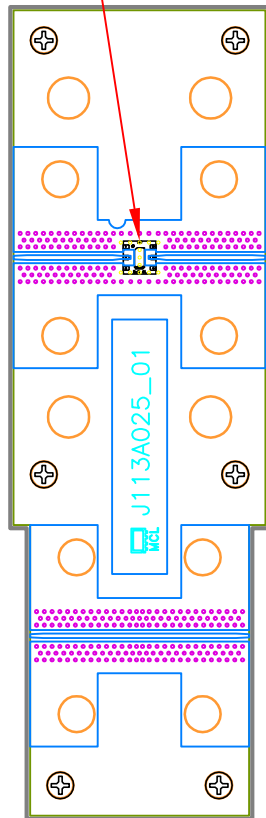

INDEX — DUT

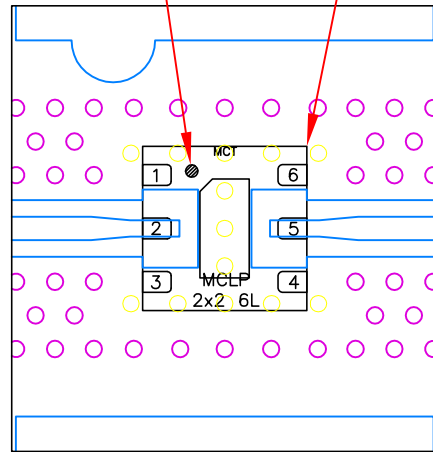

DETAIL "A"  
(SCALE 5:1)

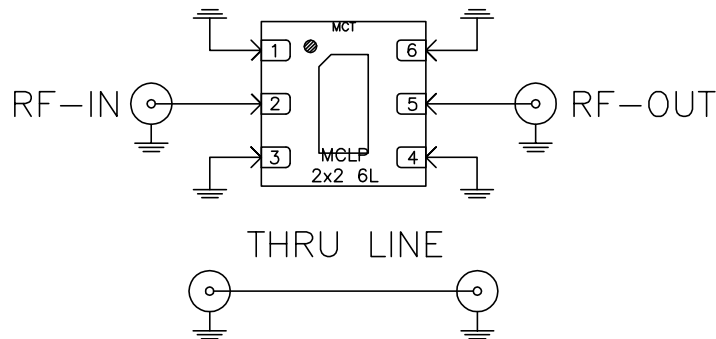

SCHEMATIC DIAGRAM

Function	Pad
RF-IN	2
RF-OUT	5
GND	1,3,4,6

## Notes:

1. PCB Material: Roger R04350B or equivalent,  
Dielectric constant=3.5, Thickness=0.0066 inch

 **Mini-Circuits®**

# Evaluation Board and Circuit

SEE DETAIL "A"

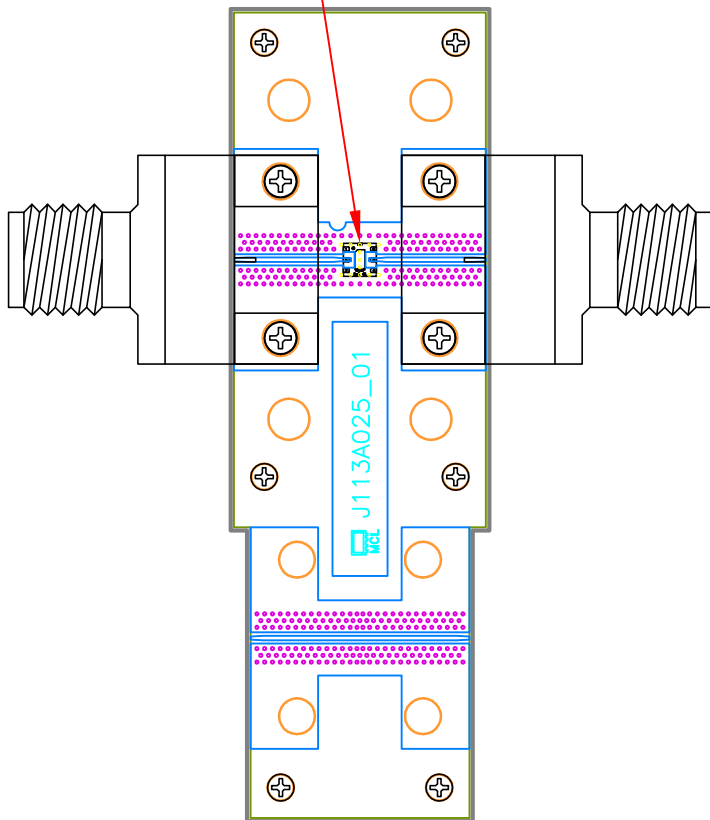

INDEX — DUT

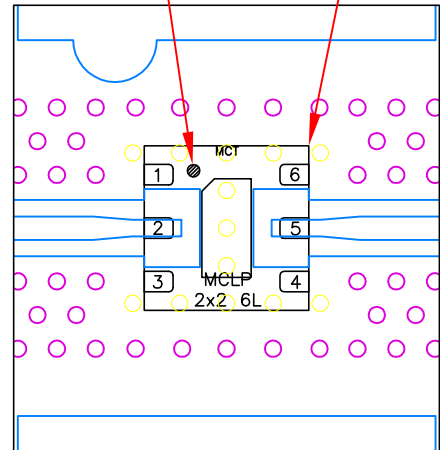

DETAIL "A"  
(SCALE 5:1)

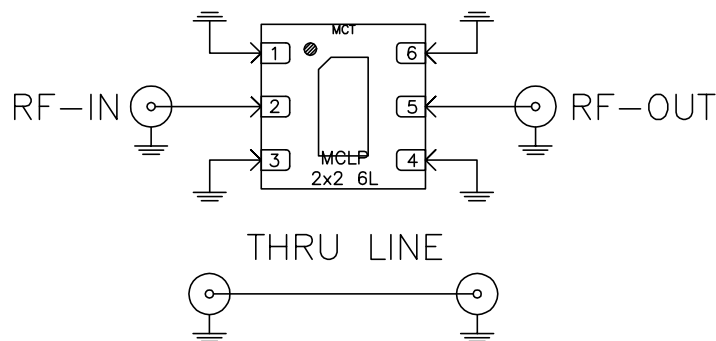

SCHEMATIC DIAGRAM

Function	Pad
RF-IN	2
RF-OUT	5
GND	1,3,4,6

## Notes:

1. 2.4mm Female Connectors.
2. PCB Material: Roger R04350B or equivalent,  
Dielectric constant=3.5, Thickness=0.0066 inch

 **Mini-Circuits®**

All Mini-Circuits products are manufactured under exacting quality assurance and control standards, and are capable of meeting published specifications after being subjected to any or all of the following physical and environmental test.

Specification	Test/Inspection Condition	Reference/Spec
Operating Temperature	-40° to 85°C Ambient Environment	Individual Model Data Sheet
Storage Temperature	-55° to 100° C or -65° to 150° Ambient Environment	Individual Model Data Sheet
Thermal Shock	-55° to 100°C, 100 cycles	MIL-STD-202, Method 107, Condition A-3, except +100°C
Mechanical Shock	1.5Kg, 0.5 ms, 5 shock pulses, Y1 direction only	MIL-STD-883, Method 2002, Condition B, except Y1 direction only
Vibration (Variable Frequency)	50g peak	MIL-STD-883, Method 2007, Condition B
Autoclave	15 psig, 100% RH, 121°C, 96 hours	JESD22-A102, Condition C
HAST	130°C, 85% RH, 96 hours	JESD22-A110
Solderability	10X Magnification	J-STD-002, Para 4.2.5, Test S, 95% Coverage
Solder Reflow Heat	Sn-Pb Eutetic Process: 240°C peak Pb-Free Process: 260°C peak	J-STD-020, Table 4-1, 4-2 and 5-2; Figure 5-1
Moisture Sensitivity: Level 1	Bake at 125°C for 24 hours Soak at 85°C/85% RH for 168 hours, Reflow 3 cycles at 260°C peak	J-STD-020
Marking Resistance to Solvents	Isopropyl alcohol + mineral spirits at 25°C; terpene defluxer at 25°C; distilled water + proylene glycol monomethyl ether +	MIL-STD-202, Method 215



All Mini-Circuits products are manufactured under exacting quality assurance and control standards, and are capable of meeting published specifications after being subjected to any or all of the following physical and environmental test.

Specification	Test/Inspection Condition	Reference/Spec
---------------	---------------------------	----------------

monoethanolamine at 63°C to 70°C