

AAT2074B2 Preliminary Data Sheet

75Ω Digital Attenuator 2-Bit 12 dB DC~2700 MHz

1. Product Overview

1.1 General Description

The AAT2074B2 is a GaAs MMIC two bit positive control digital attenuator. The device operates from DC to 2700 MHz with a control and supply voltage of +3 V or +5 V. The AAT2074B2 has LSB of 4 dB and a total attenuation of 12dB. The AAT2074B2 is composed of two cascade fixed attenuators. The states of attenuator are controlled by the logic level voltage. The attenuator bit values are 4 dB (LSB), 8 dB for a total attenuation of 12 dB. Attenuation accuracy is $\pm(0.15 \text{ dB} + 3 \% \text{ of attenuation setting}) @ \text{DC} \sim 1200 \text{ MHz}$.

1.2 Features

- 75 Ω Impedance
- Attenuation: 12 dB with 4 dB LSB
- Attenuation Accuracy:
 $\pm (0.15 \text{ dB} + 3 \% \text{ of Atten. setting}) @ \text{DC} \sim 1200 \text{ MHz}$

1.3 Applications

- Telecommunication System
- CATV and FTTH

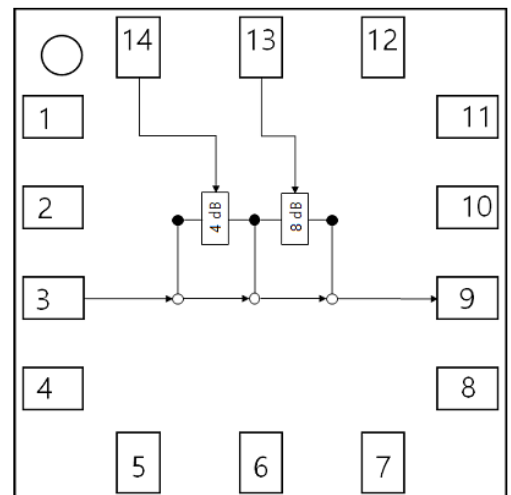

AAT2074B2 Block Diagram (X-ray view)

1.4 Package Profile & RoHS Compliance

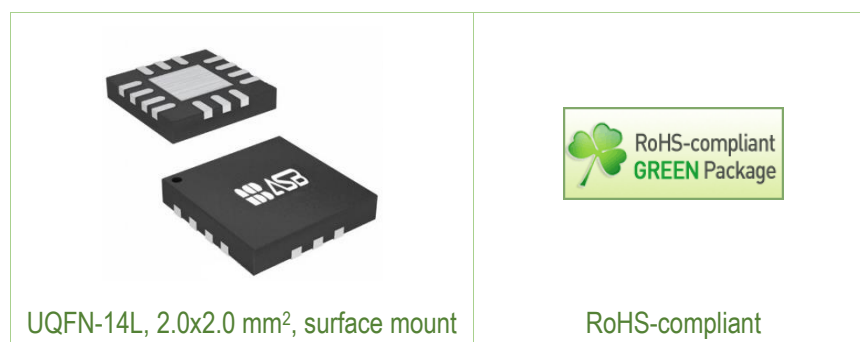

2. Summary on Product Performances

2.1 Electrical Specifications

| Parameter | Test Condition | Min | Typ | Max | Unit |
|--|-------------------|--|-----|------|------|
| Reference Insertion Loss (IL) | 50 | | 0.4 | | dB |
| | 1200 | | 0.7 | | |
| | 2000 | - | 1.0 | - | |
| | 2700 | | 2.1 | | |
| Attenuation Accuracy ¹⁾ | DC – 1200 MHz | ±(0.15 dB + 3% of attenuation setting) | | | |
| | DC – 2700 MHz | ±(0.7 dB + 10% of attenuation setting) | | | |
| Return Loss | DC – 1200 MHz | 15 | 16 | - | dB |
| | DC – 2700 MHz | 14 | 15 | | |
| Switching Characteristics: Rise/fall Time | (10% to 90% RF) | | 300 | | ns |
| On/off Time | (50% Vctrl to RF) | | 320 | | |
| Input P1dB | 50 MHz | | 26 | | dBm |
| | 1200 MHz | | 21 | | |
| | 2000 MHz | - | 20 | - | |
| | 2700 MHz | | 15 | | |
| IIP3 ²⁾ | 50 MHz | | 37 | | dBm |
| | 1200 MHz | | 37 | | |
| | 2000 MHz | - | 40 | - | |
| | 2700 MHz | | 34 | | |
| IIP2 ²⁾ | 50 MHz | | 60 | | dBm |
| | 860 MHz | | 70 | | |
| Supply Voltage (Vs) | | +3 | +5 | - | V |
| Control Voltage | High | Vs-0.5 | Vs | | V |
| | Low | 0 | - | +0.5 | |
| Current | | | 600 | | uA |

1) Attenuation accuracy are calculated at any bit or combination

2) IIP3 and IIP2 are measured with two tones at an input power of +0 dBm/tone separated by 6 MHz.

2.2 Truth Table

| State | V1 | V2 |
|----------------|------|------|
| Insertion loss | Low | Low |
| 4 dB | High | Low |
| 8 dB | Low | High |
| 12 dB | High | High |

2.3 Pin Configuration

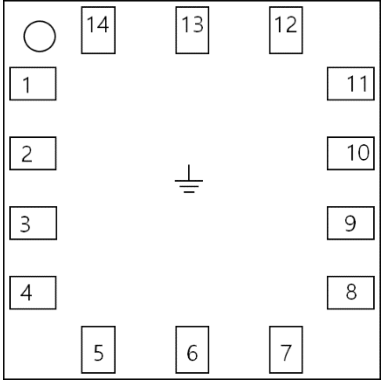
| Pin | Description | Simplified Outline |
|-----------------------|---|--|
| 1, 2, 4, 6, 8, 10, 11 | No connection |  |
| 3 | RF1, RF port | |
| 9 | RF2, RF port | |
| 5, 7 | RF GND | |
| 12 | Vs, DC power supply voltage. | |
| 13 | V2, DC control voltage. Controls 8 dB attenuation state. | |
| 14 | V1, DC control voltage. Controls 4 dB attenuation state. | |

Note: Backside metal paddle is DC ground.

2.4 Absolute Maximum Ratings

| Parameters | Max. Ratings |
|----------------------------|--|
| Operation Case Temperature | -40 to +85 °C |
| Storage Temperature | -65 to +150 °C |
| Device Voltage | +7 V |
| Input RF Power | +27 dBm @ 50 MHz +22 dBm @ 1200 MHz +15 dBm @ 2700 MHz |

2.5 Moisture Sensitivity Level

Level 3 at 260 °C reflow

(Intentionally Blanked)

3. Application: DC ~ 1200 MHz ($V_s = +5\text{ V}$, $75\ \Omega$)

3.1 Application Circuit & Evaluation Board

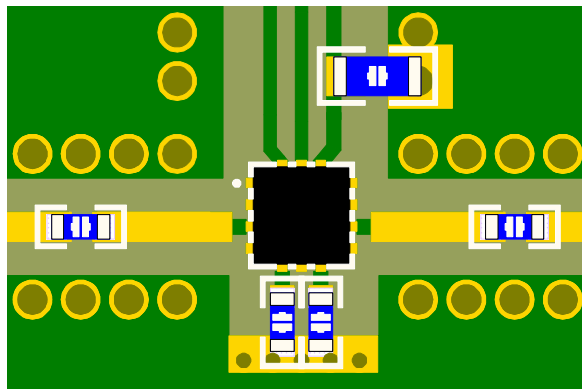
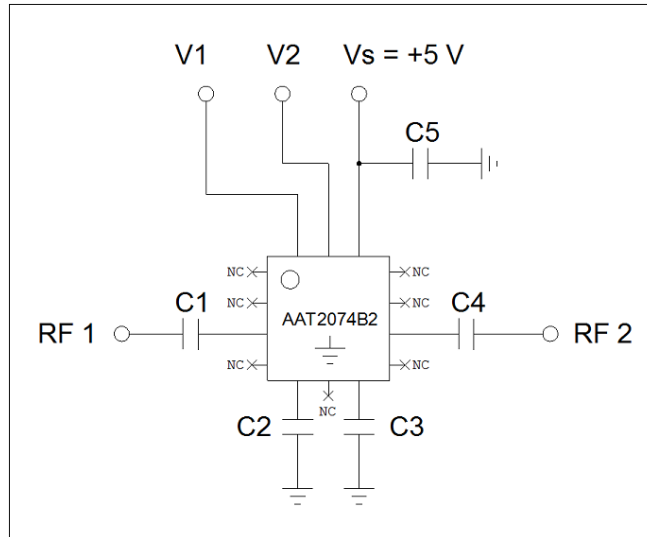

| PCB Information | |
|-----------------|--------------------|
| Material | FR4 |
| Thickness (mm) | 0.8 |
| Size (mm) | 25x50 |
| EB No. | EB-2x2-QFN14_ATT01 |

Bill of Material

| Symbol | Value | Size | Description | Manufacturer |
|-----------|------------------|------|--------------------------|--------------|
| AAT2074B2 | - | - | 2-Bit digital attenuator | ASB |
| C1, C4 | 1 μF | 0402 | DC blocking capacitor | Murata |
| C2, C3 | 1 μF | 0402 | Bypass capacitor | Murata |
| C5 | 10 μF | 0805 | Decoupling capacitor | Murata |

Note: Bypass capacitors (C2 and C3) should be close to the RF GND(pin 5 and pin 7).

3.2 Plot of Performances

Insertion loss

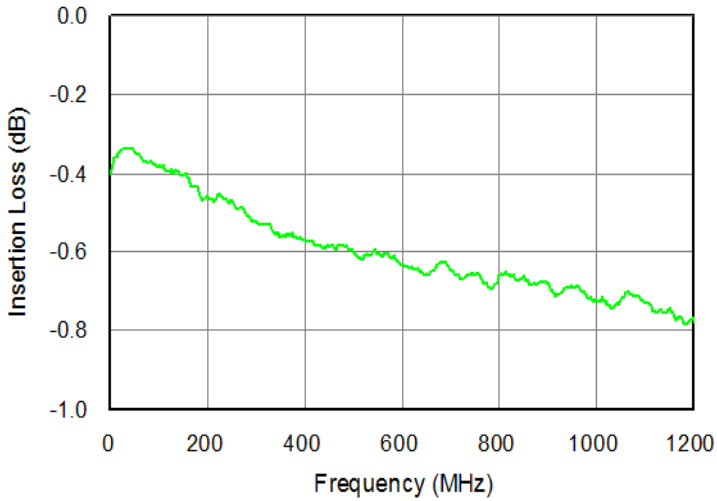

Normalized attenuation all states

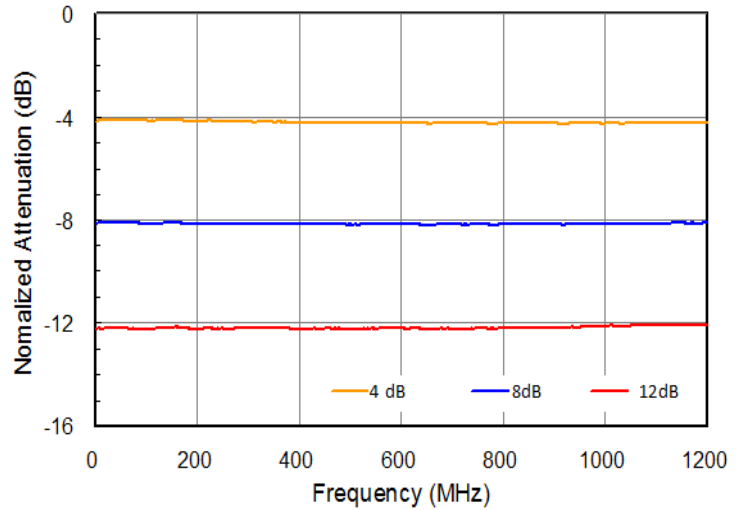

Input return loss over all states

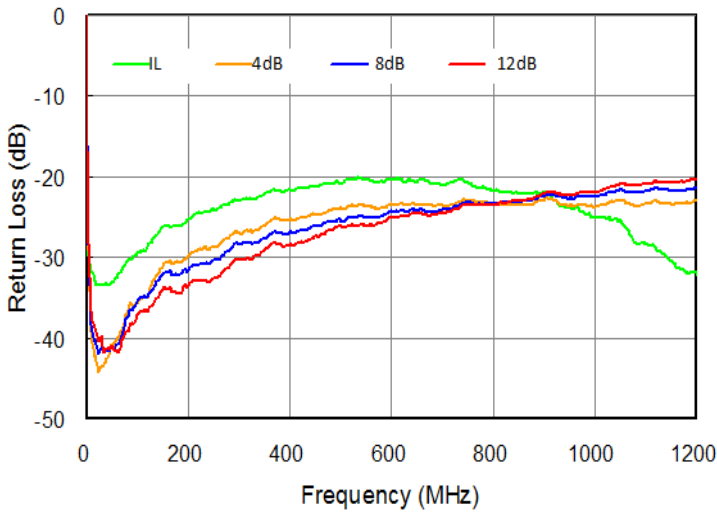

Output return loss over all states

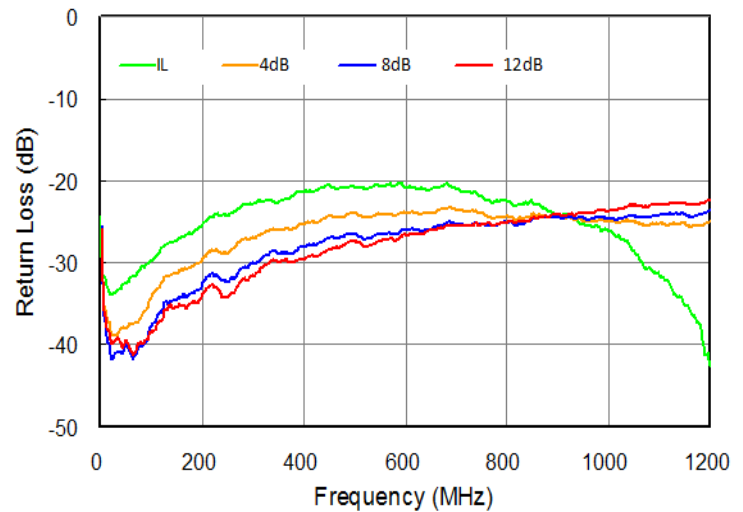

IIP3 vs. Frequency over all states

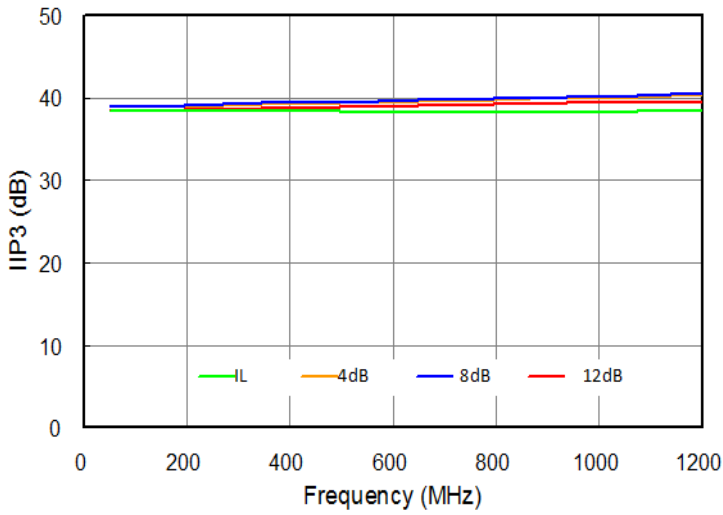

IIP2 vs. Frequency over all states

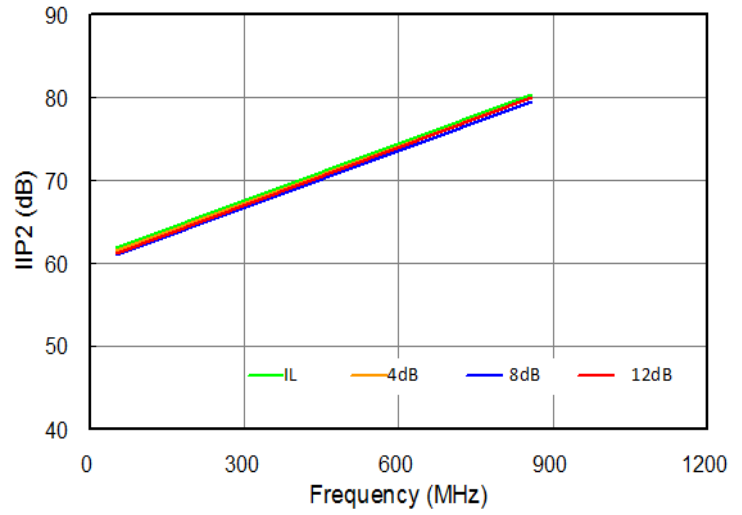

Step error vs. frequency over all states

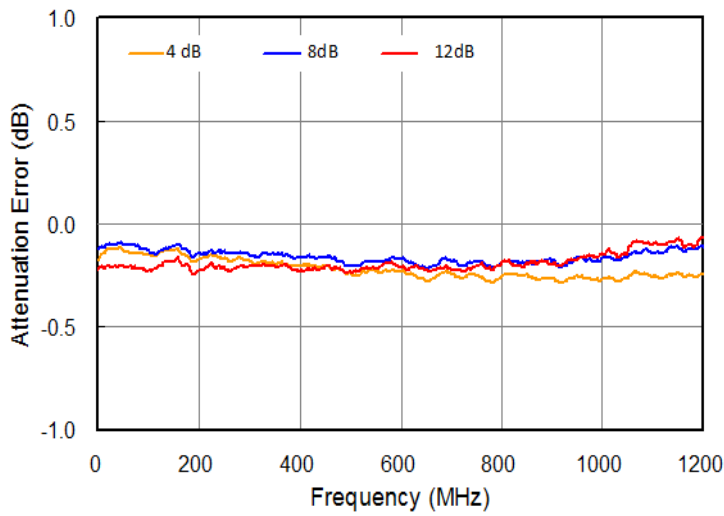

4. Application: DC ~ 2700 MHz ($V_s = +5\text{ V}$, $75\ \Omega$)

4.1 Application Circuit & Evaluation Board

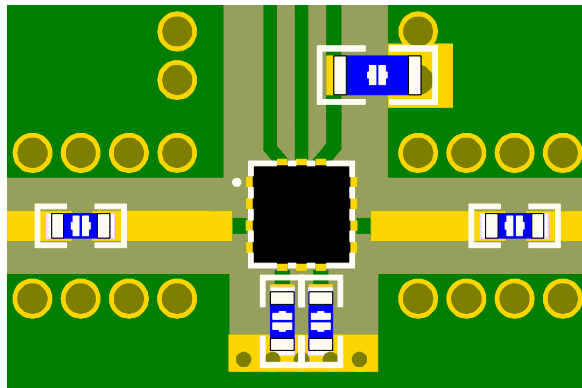
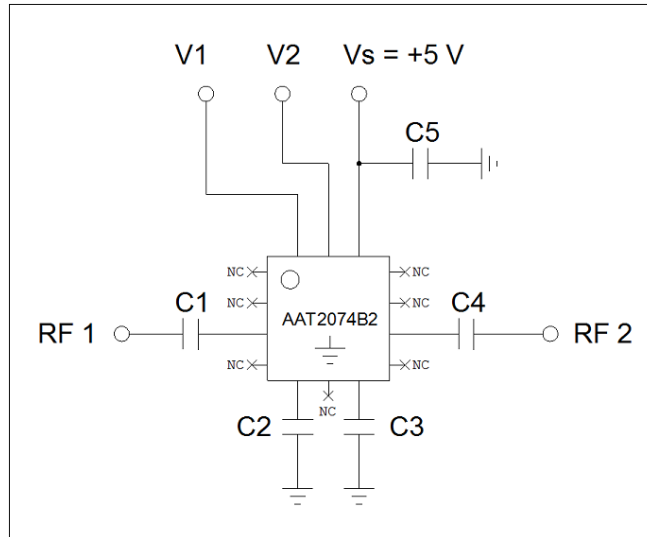

| PCB Information | |
|-----------------|--------------------|
| Material | FR4 |
| Thickness (mm) | 0.8 |
| Size (mm) | 25x50 |
| EB No. | EB-2x2-QFN14_ATT01 |

Bill of Material

| Symbol | Value | Size | Description | Manufacturer |
|-----------|------------------|------|--------------------------|--------------|
| AAT2074B2 | - | - | 2-Bit digital attenuator | ASB |
| C1, C4 | 1 μF | 0402 | DC blocking capacitor | Murata |
| C2, C3 | 1 μF | 0402 | Bypass capacitor | Murata |
| C5 | 10 μF | 0805 | Decoupling capacitor | Murata |

Note: Bypass capacitors (C2 and C3) should be close to the RF GND(pin 5 and pin 7).

4.2 Plot of Performances

Insertion loss

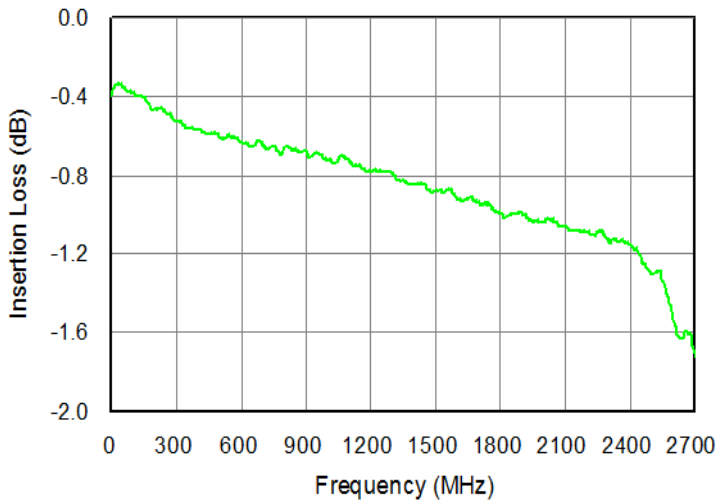

Normalized attenuation all states

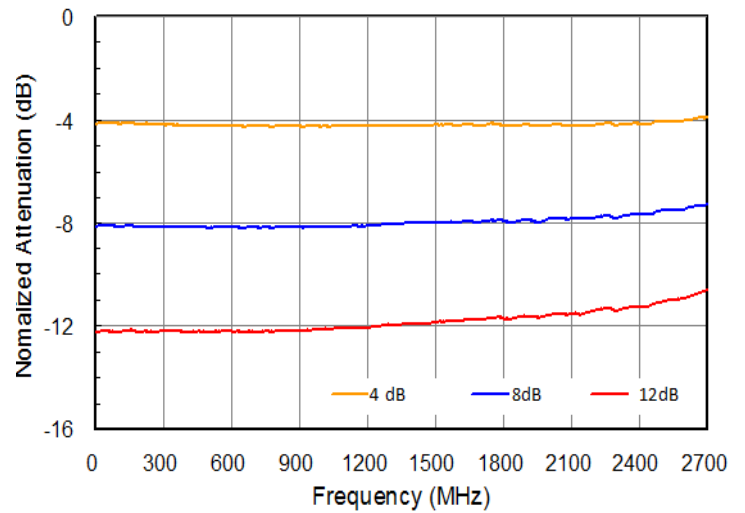

Input return loss over all states

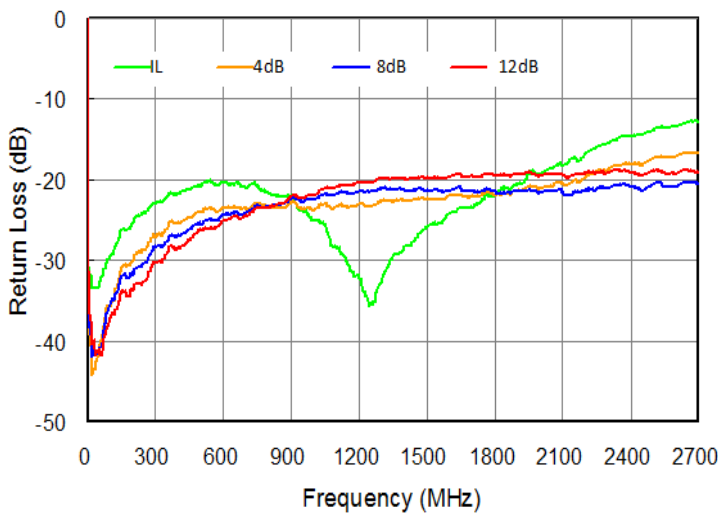

Output return loss over all states

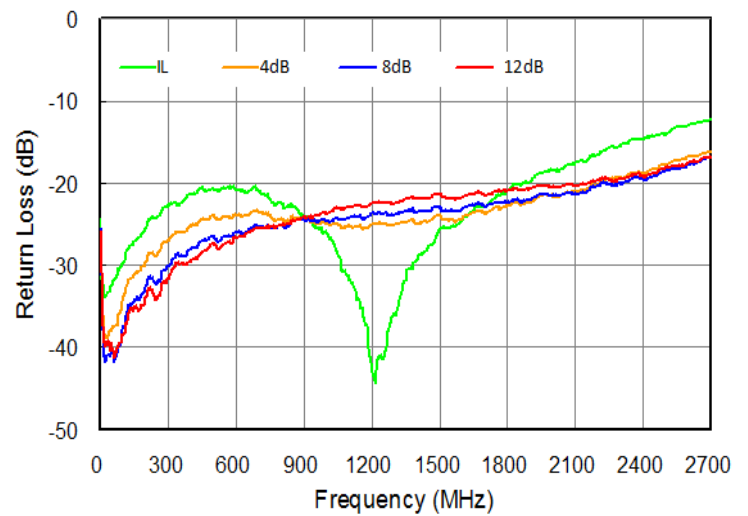

IIP3 vs. Frequency over all states

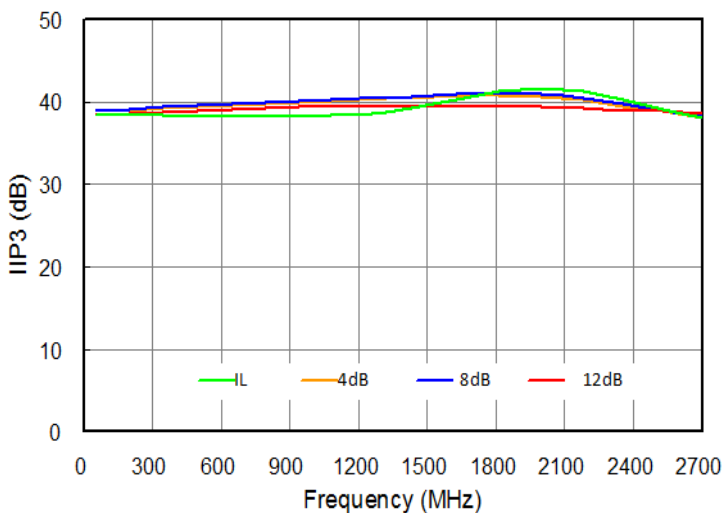

Step error vs. frequency over all states

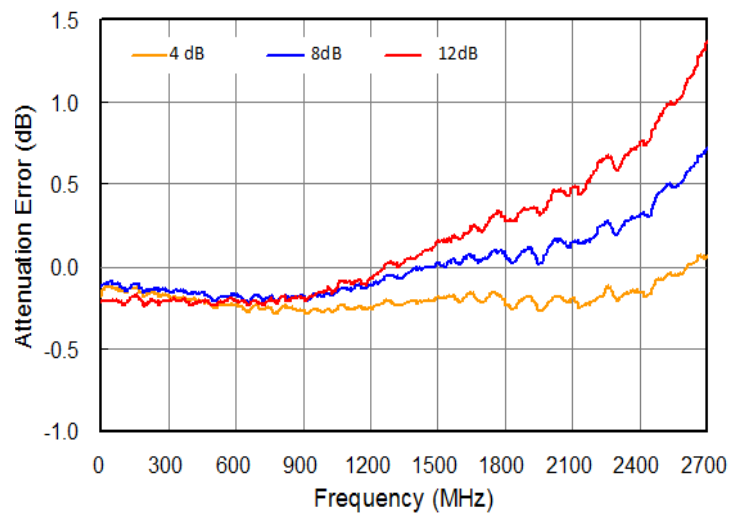

5. Package Outline (UQFN-14L, 2.0x2.0x0.4 mm³)

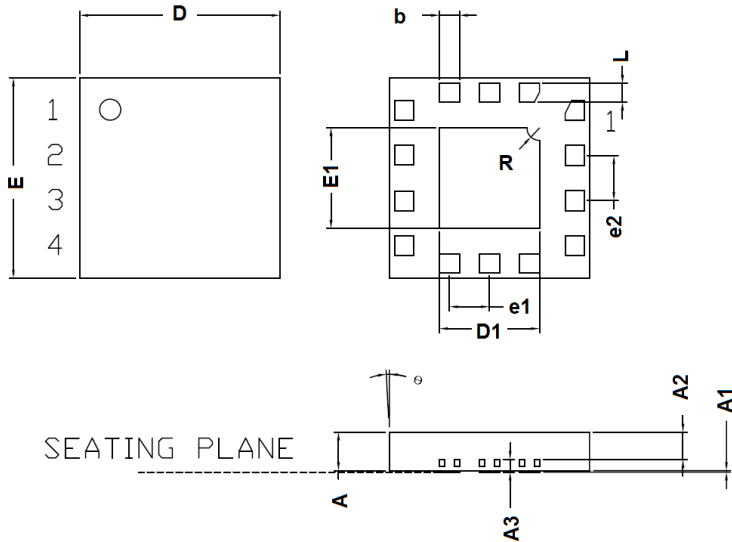

| Symbols | Dimensions (In mm) | | |
|---------|--------------------|----------|-------|
| | MIN | NOM | MAX |
| A | 0.35 | - | 0.40 |
| A1 | 0.00 | - | 0.05 |
| A2 | 0.223 | - | 0.273 |
| A3 | - | 0.127REF | - |
| b | 0.15 | 0.20 | 0.25 |
| D | 1.95 | 2.00 | 2.03 |
| E | 1.95 | 2.00 | 2.03 |
| D1 | - | 1.00BSC | - |
| E1 | - | 1.00BSC | - |
| e1 | - | 0.40BSC | - |
| e2 | - | 0.45BSC | - |
| L | 0.13 | 0.18 | 0.23 |
| R | - | 0.125BSC | - |
| theta | -12 | - | 0 |
| Burr | 0.00 | 0.03 | 0.06 |

6. Surface Mount Recommendation (In mm)

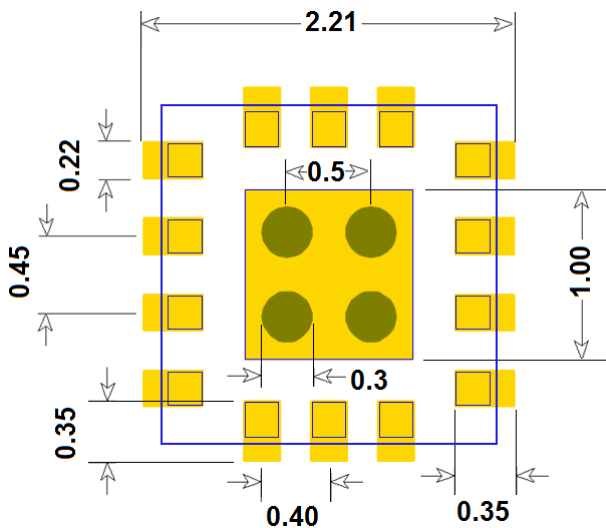

NOTE

1. Recommended is that the ground via holes be placed on the bottom of the exposed pad of the device for better RF and thermal performance, as shown in the drawing at the left side

7. Tape and Reel Information

7.1 UQFN-14L Package

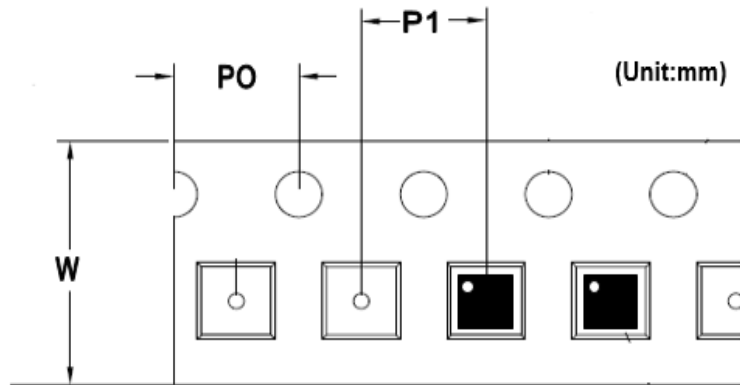

| Package | Carrier Width (W) | Pitch (P0) | Pitch (P1) | Part Per Full Reel | Reel Size |
|----------|-------------------|------------|------------|--------------------|-----------|
| UQFN-14L | 8 mm | 4 mm | 4 mm | 3,000 pcs | 180 mm |

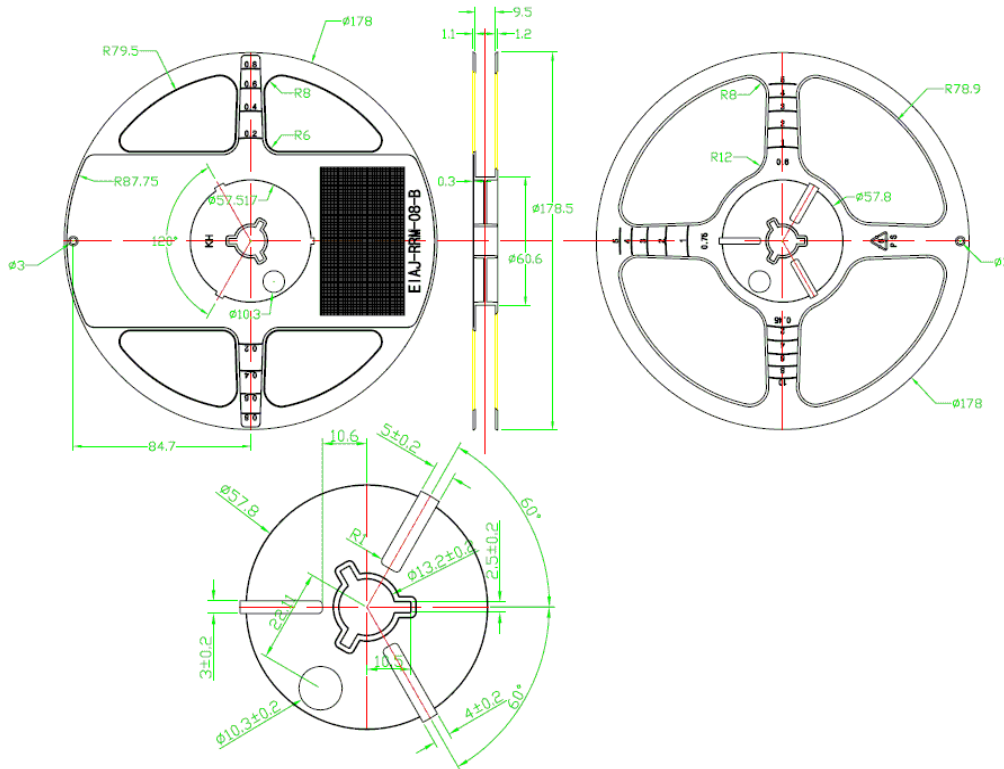

8. Recommended Soldering Reflow Profile

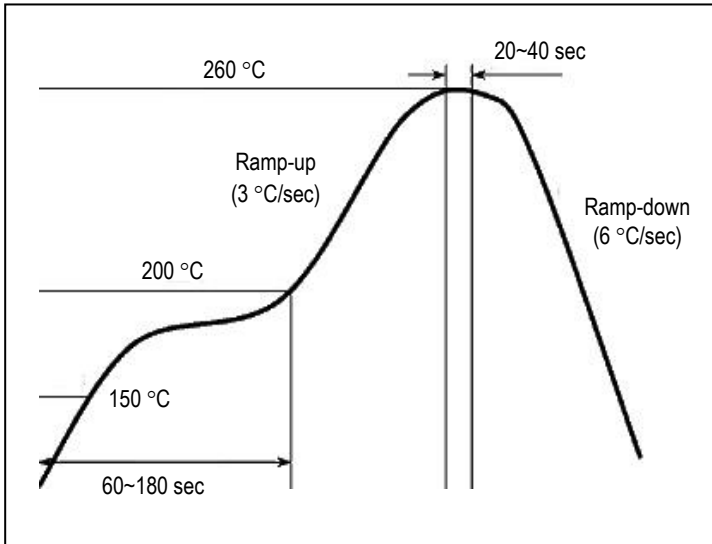

(End of Datasheet)

Copyright ©2017 ASB Inc. All rights reserved. Datasheet subject to change without notice. ASB assumes no responsibility for any errors which may appear in this datasheet. No part of the datasheet may be copied or reproduced in any form or by any means without the prior written consent of ASB.