

DESCRIPTION

The EV2487DN-00A is an evaluation board for the MP2487DN, a step down converter designed for driving up to 10 white LEDs in series with 330mA current.

The MP2487 is a peak current mode control, fixed frequency regulator to deliver a constant current of up to 1A to high power white LEDs. Its low 200mV feedback voltage reduces power loss and improves efficiency.

The wide 4.5V to 55V input range accommodates a variety of step-down applications, making it ideal for automotive, industry and general lighting application.

The MP2487 is available in a SOIC8E package.

FEATURES

- Wide 4.5V to 55V Operating Input Voltage
- Drive up to 10 WLEDs in series of 330mA
- Up to 200kHz programmable Switching Frequency
- 130µA Quiescent Current
- Up to 97.5% Efficiency
- 220mΩ Internal Power MOSFET
- 200mV reference voltage

APPLICATIONS

- High Power white LED Driver
- Automotive, Industry and General Lighting
- Constant Current Source

ELECTRICAL SPECIFICATIONS

Parameter	Symbol	Value	Units
Input Voltage	V _{IN}	40 – 55	V
# of WLEDs		10 (in series)	
LED Current	I _{LED}	330	mA

“MPS” and “The Future of Analog IC Technology” are Registered Trademarks of Monolithic Power Systems, Inc.

EV2487DN-00A EVALUATION BOARD



(L x W x H) 2" x 1.8" x 0.4"
5.3cm x 4.6cm x 1.0cm

EV2487DN-00A	MP2487DN
--------------	----------

Board Number	MPS IC Number
--------------	---------------

Efficiency vs. Input Voltage

10 WLED@330mA

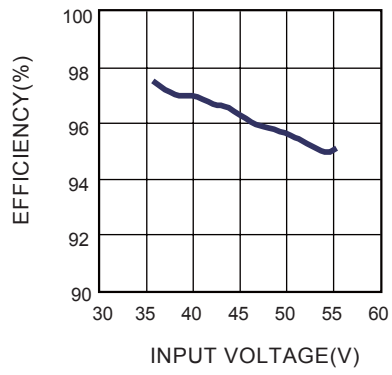

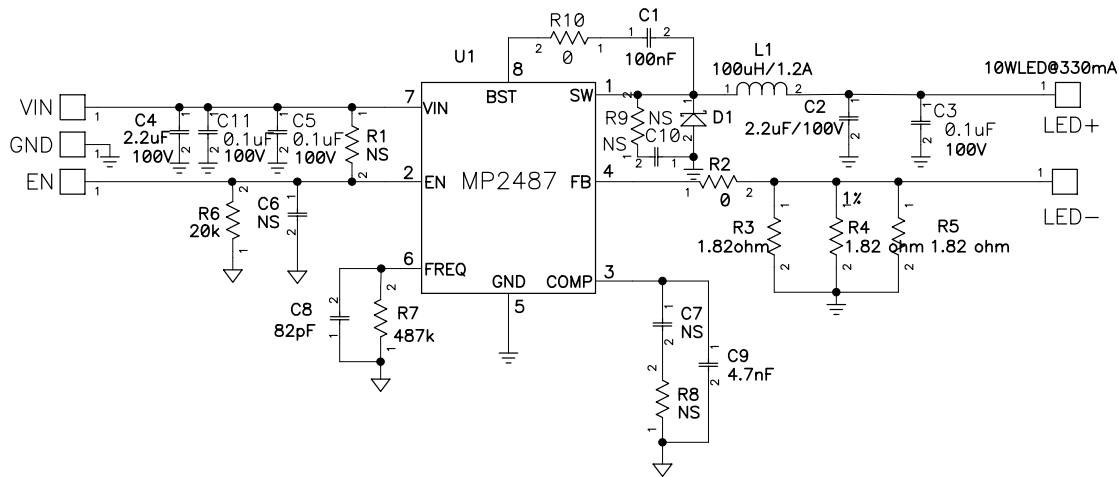
EVALUATION BOARD SCHEMATIC

EV2487DN-00A BILL OF MATERIALS

Qty	Ref	Value	Description	Package	Manufacturer	Manufacturer P/N
1	C8	82pF/50V	Cemarc capacitor,50V,COG	0603	TDK	C1608COG1H820JK
1	C1	100nF/50V	Cemarc capacitor,50V,X7R	0603	TDK	C1608X7R1H104K
1	C9	4.7nF/50V	Cemarc capacitor,50V,X7R	0603	TDK	C1608X7R1H472K
2	C6,C7	NS				
3	C3,C5,C11	0.1μF/100V	Cemarc capacitor,100V,X7R	0805	TDK	C2012X7R2A104K
1	C10	NS				
2	C2,C4	2.2μF/100V	Cemarc capacitor,100V,X7R	1210	TDK	C3225X7R2A225K
1	D1	1A/90V	schottky diode 90V, 1A	SMA	TDK	B190A
1	U1	MP2487DN_LF	WLED Driver	SOIC8E	MPS	MP2487DN_LF
2	R2,R10	0Ω	Film, 5%	0603	Yageo	RC0603JR-070RL
1	R8,R9	NS				
1	R6	20kΩ	Film, 1%	0603	Yageo	RC0603FR-0720KL
1	R7	487kΩ	Film, 1%	0603	Yageo	RC0603FR-074878KL
1	R1	NS				
3	R3,R4,R5	1.82Ω	Film, 1%	0805	Yageo	RC0805FR-071R82L
1	L1	100μH	Inductor, 100μH,1.3A, 255mΩ	SMD	TOKO	DS106C2-B966BS-101MP3

PRINTED CIRCUIT BOARD LAYOUT

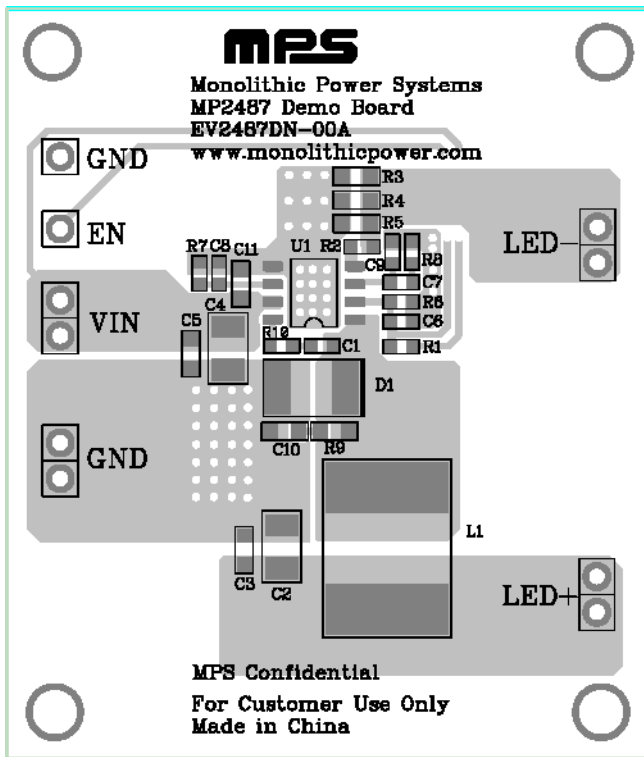

Figure 1—Top Layer

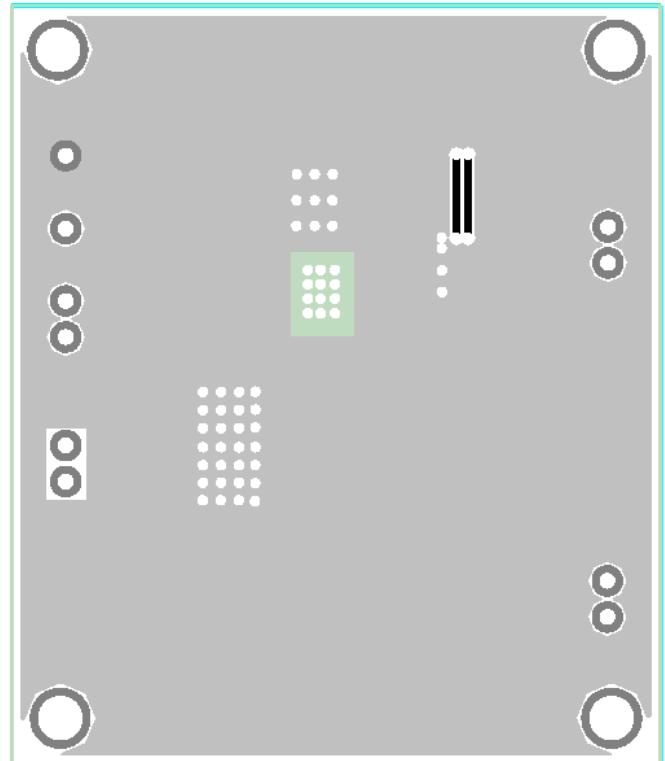

Figure 2—Bottom Layer

QUICK START GUIDE

1. Connect the positive and negative terminals of the WLED (10WLED in series) load to the LED+ and LED- pins on the EV board, respectively.
2. Connect the positive and negative terminals of the power supply (40V ~ 55V) to the VIN and GND pins on the EV board, respectively. Turn the power supply on.
3. Drive EN pin high ($V_{EN} > 1.7V$) to enable the MP2487.
4. For PWM dimming mode, apply a PWM signal with high level greater than 1.7V to the EN pin. The typical PWM frequency should be around 200Hz. The WLED brightness can be controlled by the PWM dimming duty cycle.

NOTICE: The information in this document is subject to change without notice. Users should warrant and guarantee that third party Intellectual Property rights are not infringed upon when integrating MPS products into any application. MPS will not assume any legal responsibility for any said applications.