



## VHRF20-28 SERIES

HIGH RELIABILITY COTS DC-DC CONVERTERS

**Models Available**  
 20 A output  
 -40 °C to 100 °C Operation

# DATASHEET

### 1.0 DESCRIPTION

The VHRF20 series of COTS EMI filters is a cost effective solution use in defense, avionics and manufacturing industries. A wide input voltage range accommodates nominal 28 V inputs. The VHRF20 EMI filter is designed to filter the conducted emissions of multiple VHR series DC-DC converters up to its current rating, providing compliance to MIL-STD-461D-F for conducted emissions. A proven design heritage, no optoisolators and a rugged all metal package ensures long term reliability.

The VHRF20 series is intended non flight-critical solutions in military, avionics, unmanned systems as well as manufacturing equipment and controls. Testing is to JESD22, MIL-STD-810, and MIL-STD-883.

These converters are designed and manufactured in a facility certified to ISO9001, J-STD-001 and IPC-A-610.

This product may incorporate one or more of the following U.S. patents:

- 5,784,266
- 5,790,389
- 5,963,438
- 5,999,433
- 6,005,780
- 6,084,792
- 6,118,673



### 1.1 FEATURES

- High Reliability at Low Cost
- Up to 20.0 Amp Maximum Current
- Up to 400 W Output Power
- Wide Input Voltage Range: 0 to 50 Volts per MIL-STD-704 and MIL-STD-1275
- High Input Transient Voltage: 80 Volts for 1 sec per MIL-STD-704A
- 45 dB Minimum Attenuation at 500 kHz
- Wide Temperature Range, -40 °C to 100 °C
- Internally Conformal Coated
- Standard Six Sided Non-Hermetic Rugged Metal Package
- Meets MIL-STD-461C-F and EN55022 Conducted Emissions Requirements When Used With a VHR Series DC-DC Converter
- Meets Conducted Susceptibility Requirements of MIL-STD-461C, CS01 and CS02, and MIL-STD-461C-F when used with a VHR Series DC-DC Converter

### 1.2 COMPLIANCE

- MIL-STD-1275
- MIL-STD-704
- Meets MIL-STD-461C-F and EN55022 when used with an appropriate VHR DC-DC Converter

### 1.3 PACKAGING

- Low-profile: 2.350" x 1.550" x 0.465"
- Max weight: 75 g

### 1.4 SIMILAR PRODUCTS AND ACCESSORIES

- [DVME28](#) 15 A EMI filter for military/avionics applications
- [VXRF20-28](#) 20 A EMI filter for military/commercial applications
- [VPTF20](#) 20 A EMI filter for military/commercial applications
- [EMI filters, Thermal Pads, Front-End Modules and Accessories](#)

2.0 DESCRIPTION

2.1 BLOCK DIAGRAM

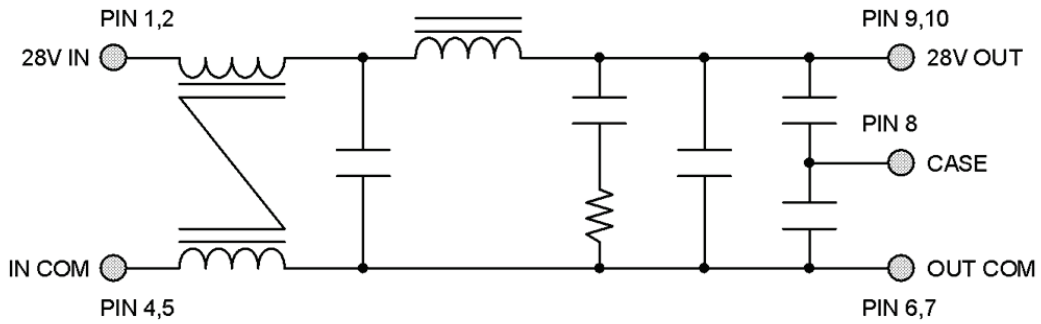

2.2 CONNECTION DIAGRAM

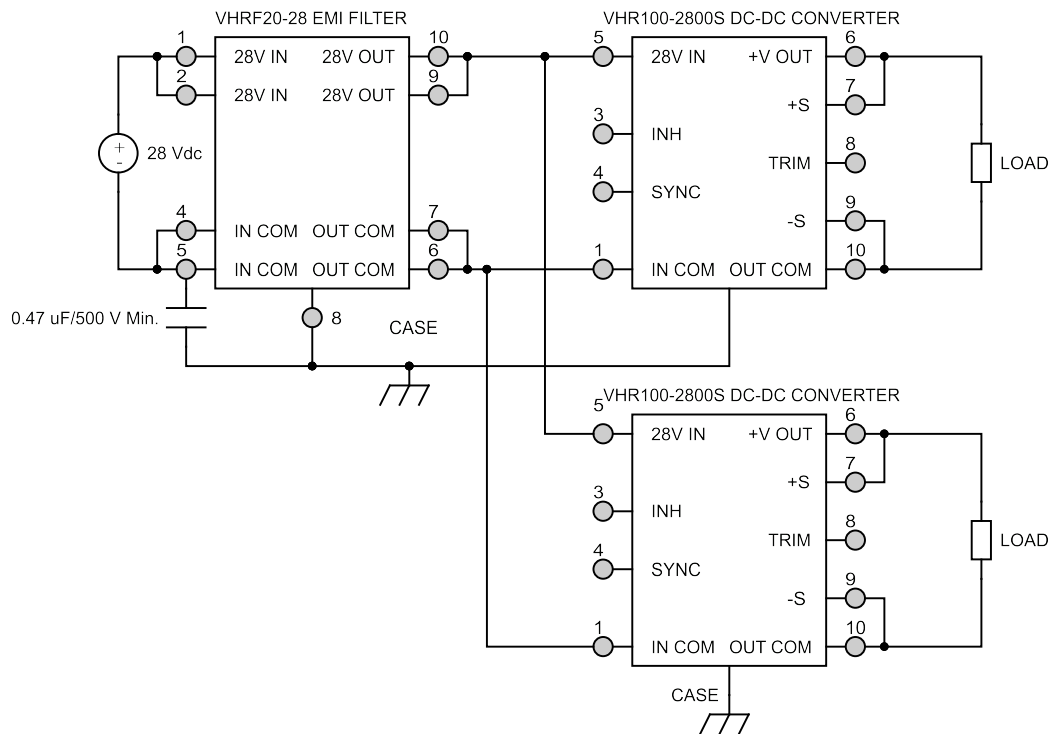

### 3.0 SPECIFICATIONS

#### 3.1 ABSOLUTE MAXIMUM RATINGS

##### Absolute Maximum Ratings

Input Voltage (Continuous)	50 V	Storage Temperature	-55 °C to 125 °C
Input Voltage (Transient, 1 second)	80 V	Lead Solder Temperature (10 seconds)	300 °C

#### 3.2 PERFORMANCE SPECIFICATIONS

T<sub>case</sub> = -40 °C to 100 °C, V<sub>in</sub> = +28 V ± 5%, Full Load, Unless Otherwise Specified

VHRF20-28					
Parameter	Conditions	Min	Typ	Max	Units
<b>INPUT</b>					
Voltage	Continuous	0	28	50	V
	Transient, 1 sec <sup>2</sup>	-	-	80	V
<b>OUTPUT STATIC</b>					
Voltage		$V_{OUT} = V_{IN} - (I_{IN} \times R_{DC})$			V
Current <sup>1</sup>		0	-	20	A
Power		0	-	400	W
<b>GENERAL</b>					
DC Resistance		-	25	50	mΩ
Power Dissipation <sup>2</sup>		-	-	20	W
Noise Rejection	f = 500 kHz	45	-	-	dB
Capacitance	Any Pin to Case	70	-	130	nF
Isolation	Any Pin to Case, 500 VDC	100	-	-	MΩ
Weight		-	-	75	g
MTBF (MIL-HDBK-217F)	GM @ TC = 55 °C	-	739	-	kHr

1. Derate linearly to 0 at 110 °C
2. Verified by qualification testing

### 4.0 PERFORMANCE CURVES

Tcase = 25 °C, Vin = +28 V ± 5%, Full Load, Unless Otherwise Specified

#### 4.1.1 One VHR100-2800S without VHRF20-28 EMI Filter

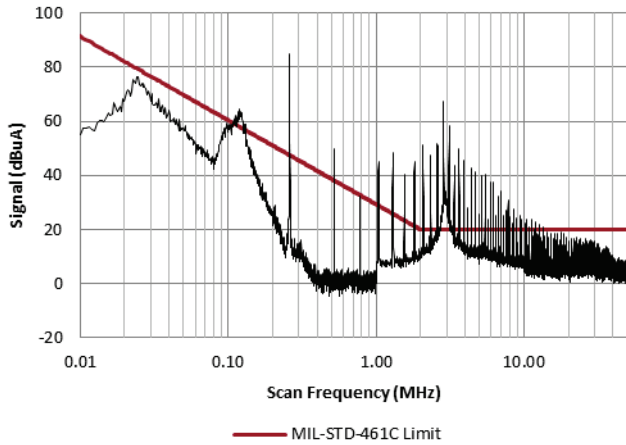

#### 4.1.2 One VHR100-2800S with VHRF20-28 EMI Filter

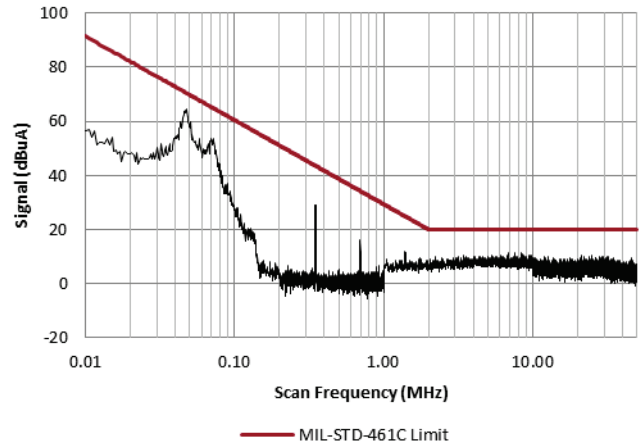

#### 4.1.3 Two VHR100-2800S without VHRF20-28 EMI Filter

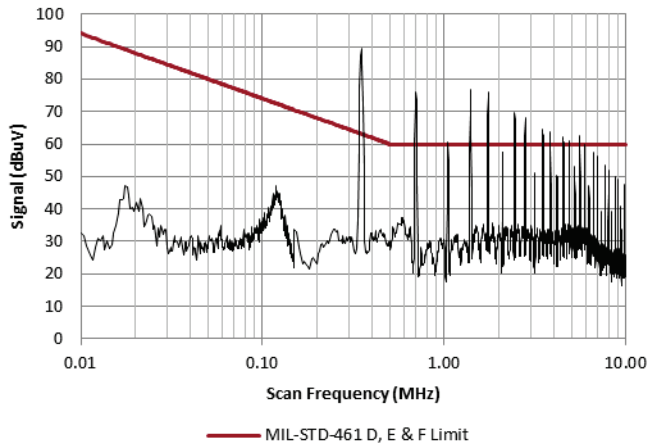

#### 4.1.4 Two VHR100-2800S with VHRF20-28 EMI Filter

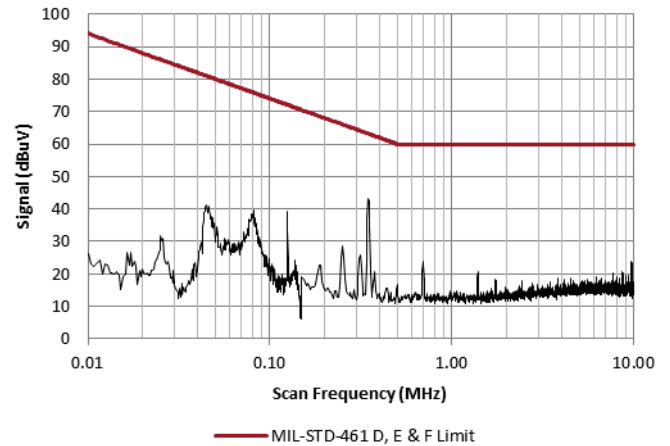

#### 4.1.5 Two VHR100-2800S with VHRF20-28 EMI Filter<sup>1, 2, 3</sup>

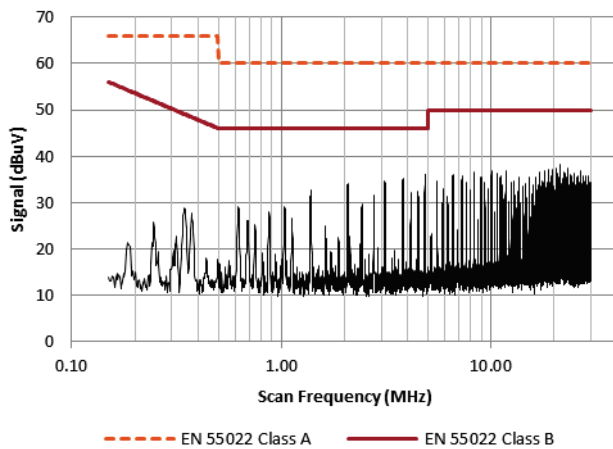

Note 1: Minimum 0.47 uF 500 V capacitor required as shown in Section 2.2

Note 2: Tcase = 25 °C, Vin = +24 V ± 5%, Full Load

Note 3: Limit lines shown are average limit

5.0 MECHANICAL OUTLINES AND PINOUT

Standard Metal Package:

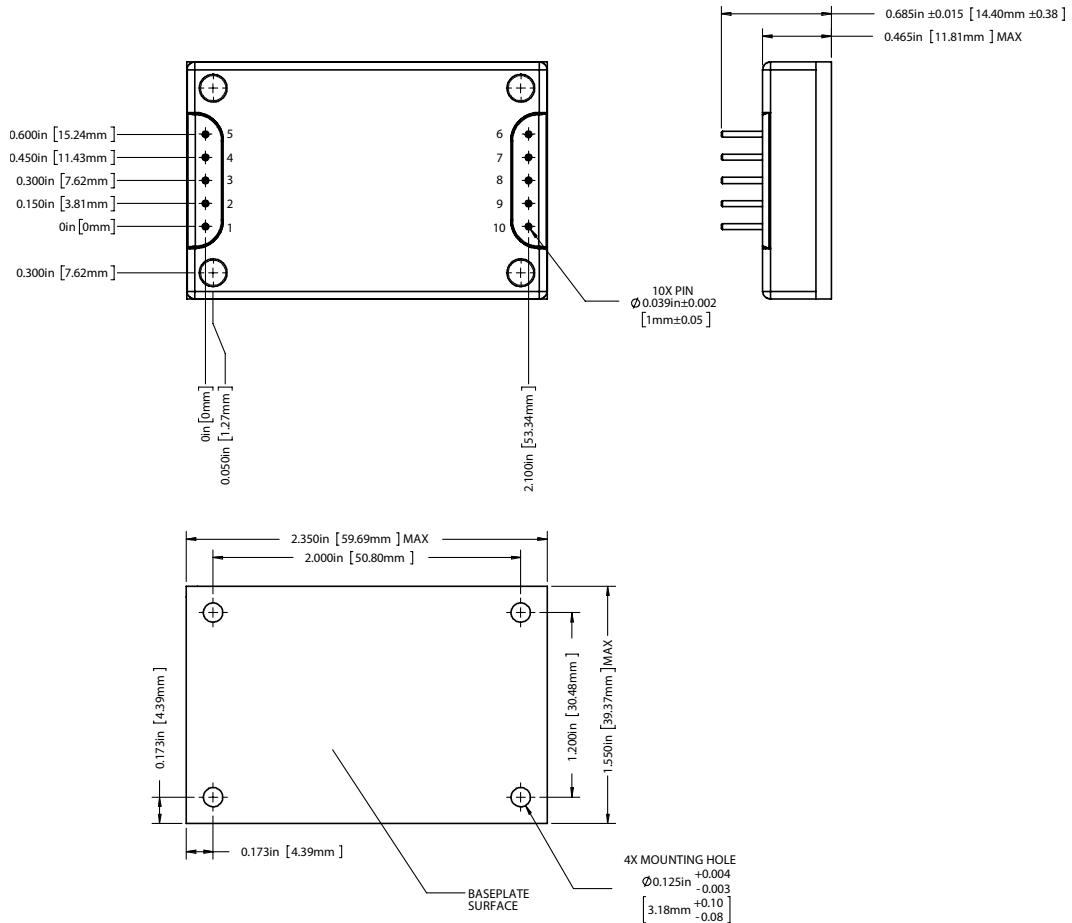

1. Case temperature is measured on the center of the baseplate surface.
2. Materials: Baseplate (Aluminum, conductive conversion coating); Cover (Nickel Plated); Pins (Copper, gold over nickel plating)
3. Mounting holes are not threaded. Recommended fastener is 4-40
4. This Package is not hermetic. VPT offers a wide range of hermetic products. Please contact VPT for details if hermetic products are required.

Pin	Function	Pin	Function
1	VIN	6	OUTCOM
2	VIN	7	OUTCOM
3	N/C	8	CASE
4	INCOM	9	VOUT
5	INCOM	10	VOUT



### 6.0 PACKAGE PIN DESCRIPTION

Pin	Function	Description
1	28VIN	Positive Input Voltage Connection
2	28VIN	Positive Input Voltage Connection
3	N/C	No Connection
4	INCOM	Input Return Connection
5	INCOM	Input Return Connection
6	OUTCOM	Output Return Connection
7	OUTCOM	Output Return Connection
8	CASE	Case Connection
9	28VOUT	Positive Output Voltage Connection
10	28VOUT	Positive Output Voltage Connection

### 7.0 ENVIRONMENTAL SCREENING

Screening	Condition
Internal Visual	IPC-A-610, Class 3
Final Electrical	100% at 25 °C
External Visual	Internal Procedure

### 8.0 ORDERING INFORMATION

<b>VHRF20</b>	<b>28</b>
1	2

(1) Product Series	(2) Nominal Input Voltage
-----------------------	------------------------------

**VHRF20- 28 28 Volts**

Please contact your sales representative or the VPT Inc. Sales Department for more information concerning additional environmental screening and testing, different input voltage, output voltage, power requirements, and source inspection.

9.0 CONTACT INFORMATION

To request a quotation or place orders please contact your sales representative or the VPT, Inc. Sales Department at:

Phone: (425) 353-3010  
 Fax: (425) 353-4030  
 E-mail: vptsales@vptpower.com

All information contained in this datasheet is believed to be accurate, however, no responsibility is assumed for possible errors or omissions. The products or specifications contained herein are subject to change without notice. VPT, its logo and tagline are registered trademarks in the U.S. Patent and Trademark Office.

10.0 ADDITIONAL INFORMATION

Visit the [VPT website](http://www.vptpower.com) for additional technical resources, including:

[Product Literature](#)



[Application Notes and White Papers](#)

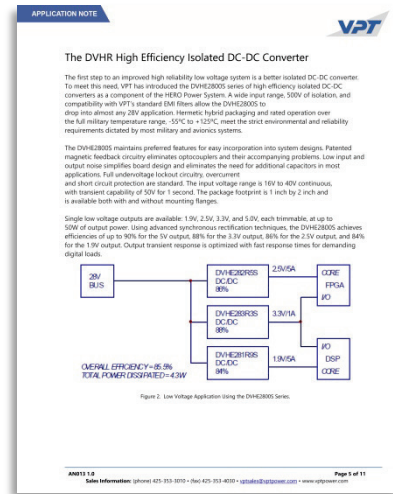

[Technical Video Labs](#)



[Additional Products For Avionics/Military, Hi-Temp, Hi-Rel COTS, and Space Applications](#)

