

CATALOG NUMBER	MATERIAL NUMBER	CABLE RANGE	NOMINAL ROD DIAMETER	LENGTH "M"	LENGTH "B"	APPROXIMATE BREAK STRENGTH* (LBS / N)	UL LISTED	CSA APPROVED	PRODUCT SELECTION NUMBER
35865	1300950124	.50-.61 / 12.7-15.5	.55 / 14.0	16.00±2.00 / 406.4±50.8	5.00±0.50 / 127.0±12.7	5600 / 24910	N	O	PS050-2
35866	1300950125	.62-.74 / 15.7-18.8	.68 / 17.3	16.00±2.00 / 406.4±50.8	5.00±0.50 / 127.0±12.7	6800 / 30248			PS062-2
35880	1300950135	.75-.99 / 19.1-25.1	.87 / 22.1	32.00±3.50 / 812.8±88.9	6.00±0.50 / 152.4±12.7	9600 / 42703			PS075-3
35881	1300950136	1.00-1.49 / 25.4-37.8	1.24 / 31.5	33.00±3.50 / 838.2±88.9	7.00±1.00 / 177.8±25.4	16400 / 72951			PS100-3
35882	1300950137	1.50-1.99 / 38.1-50.5	1.74 / 44.2	34.00±3.50 / 863.6±88.9	7.00±1.00 / 177.8±25.4	16400 / 72951			PS150-3
35883	1300950138	2.00-2.49 / 50.8-63.2	2.24 / 56.9	36.00±3.50 / 914.4±88.9	9.00±1.00 / 228.6±25.4	27200 / 120992			PS200-3
35884	1300950139	2.50-2.99 / 63.5-75.9	2.74 / 69.6	38.00±3.50 / 965.2±88.9	10.00±1.00 / 254.0±25.4	33000 / 146791			PS250-3
35886	1300950141	3.50-3.99 / 88.9-101.3	3.74 / 95.0	41.00±4.50 / 1041.4±114.3	10.00±1.00 / 254.0±25.4	48000 / 213515			PS350-3
35887	1300950142	4.00-4.49 / 101.6-114.0	4.24 / 107.7	42.00±4.50 / 1066.8±114.3	10.00±1.00 / 254.0±25.4	48000 / 213515			PS400-3
35897	1300950143	4.50-4.99 / 114.3-126.7	4.74 / 120.4	58.00±5.00 / 1473.2±127.0	10.00±1.00 / 254.0±25.4	48000 / 213515			PS450-4
35898	1300950144	5.00-5.99 / 127.0-152.1	5.49 / 139.4	60.00±5.00 / 1524.0±127.0	10.00±1.00 / 254.0±25.4	48000 / 213515			PS500-4
35899	1300950145	6.00-6.99 / 152.4-177.5	6.49 / 164.8	50.00±5.00 / 1270.0±127.0	10.00±1.00 / 254.0±25.4	48000 / 213515			PS600-4

*TO DETERMINE RECOMMENDED WORKING LOAD, DIVIDE BREAK STRENGTH BY 5.

ROTATING EYE DIMENSIONS - REFERENCE						
CATALOG NUMBER	DIAMETER "C"	LENGTH "D"	LENGTH "E"	LENGTH "F"	LENGTH "G"	LENGTH "H"
35865	.875 / 22.23	.187 / 4.75	2.750 / 69.85	.281 / 7.14	.250 / 6.35	.875 / 22.23
35866	.875 / 22.23	.187 / 4.75	2.750 / 69.85	.281 / 7.14	.250 / 6.35	.875 / 22.23
35880	1.000 / 25.40	.219 / 5.56	3.625 / 92.08	.500 / 12.70	.312 / 7.92	.906 / 23.01
35881	1.375 / 34.93	.344 / 8.74	4.625 / 117.48	.500 / 12.70	.375 / 9.53	1.000 / 25.40
35882	1.375 / 34.93	.344 / 8.74	4.625 / 117.48	.500 / 12.70	.375 / 9.53	1.000 / 25.40
35883	1.625 / 41.275	.375 / 9.53	5.437 / 138.10	.625 / 15.88	.500 / 12.70	1.187 / 30.15
35884	1.875 / 47.625	.437 / 11.1	6.250 / 158.75	.656 / 16.66	.500 / 12.70	1.375 / 34.93
35886	1.875 / 47.625	.437 / 11.1	6.250 / 158.75	.656 / 16.66	.500 / 12.70	1.375 / 34.93
35887	1.875 / 47.625	.437 / 11.1	6.250 / 158.75	.656 / 16.66	.500 / 12.70	1.375 / 34.93
35897	1.875 / 47.625	.437 / 11.1	6.250 / 158.75	.656 / 16.66	.500 / 12.70	1.375 / 34.93
35898	1.875 / 47.625	.437 / 11.1	6.250 / 158.75	.656 / 16.66	.500 / 12.70	1.375 / 34.93
35899	1.875 / 47.625	.437 / 11.1	6.250 / 158.75	.656 / 16.66	.500 / 12.70	1.375 / 34.93

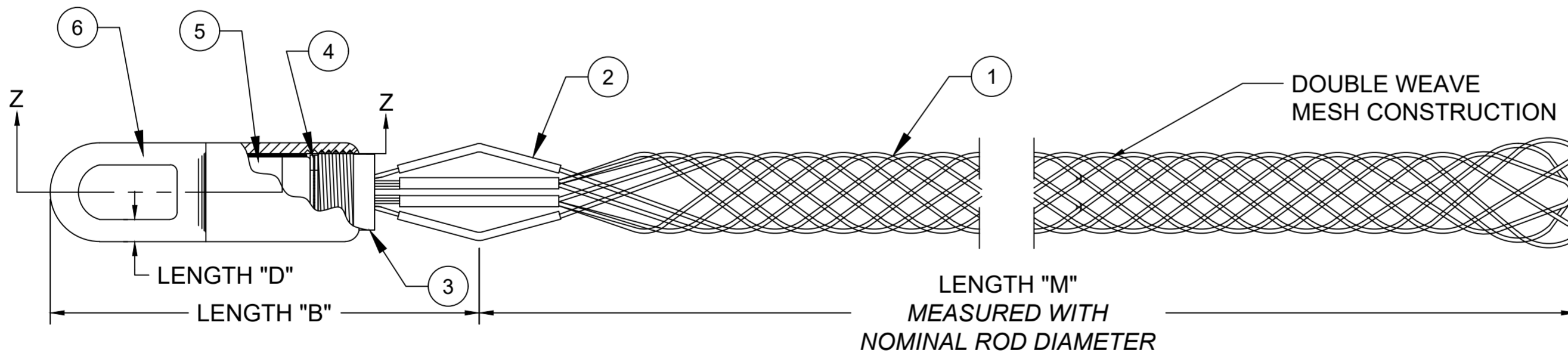
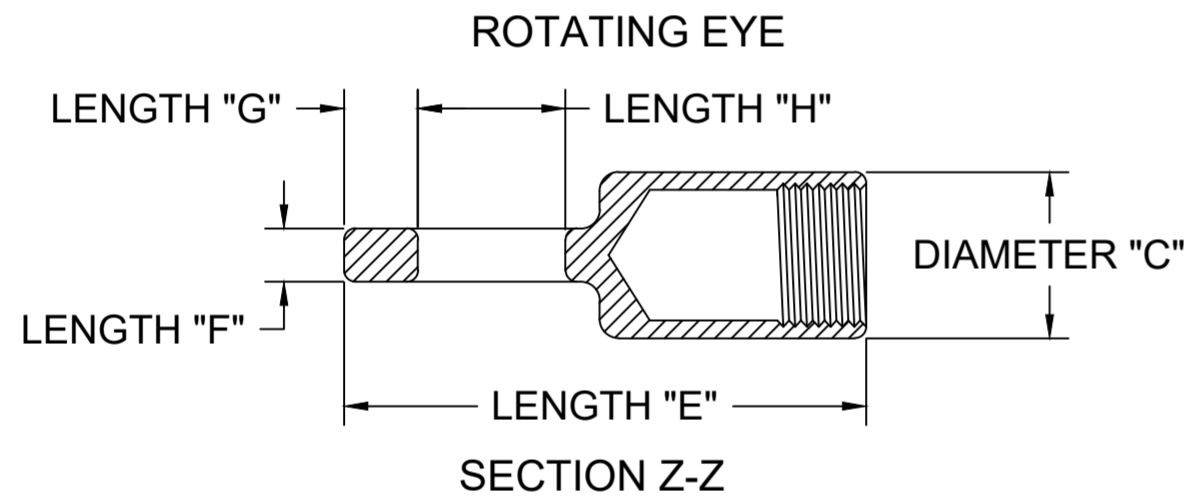

ITEM	DESCRIPTION	MATERIAL
1	WIRE MESH	GALVANIZED STEEL
2	SHOULDER PROTECTOR	ALUMINUM
3	THREADED INSERT	STEEL
4	FLAT WASHERS	NYLATRON
5	SWAGING FERRULE	STEEL
6	ROTATING EYE	STEEL

INSTRUCTION SHEET TO BE INCLUDED WITH GRIP.

FUNCTIONAL SYMBOLS $\nabla_A=0$ $\nabla_C=0$ $\nabla_P=0$ DIVISIONAL SYMBOLS	THIS DRAWING CONTAINS INFORMATION THAT IS PROPRIETARY TO MOLEX ELECTRONIC TECHNOLOGIES, LLC AND SHOULD NOT BE USED WITHOUT WRITTEN PERMISSION DIMENSION UNITS: INCH/MM SCALE: NTS CURRENT REV DESC: REMOVED OBSOLETE PART NUMBER AS PER PCN#5099889.	molex PULLING GRIPS HEAVY DUTY STANDARD LENGHT K-TYPE PRODUCT CUSTOMER DRAWING																			
	GENERAL TOLERANCES (UNLESS SPECIFIED) <table border="1"> <tr><th></th><th>mm</th><th>INCH</th></tr> <tr><td>4 PLACES</td><td>±----</td><td>±----</td></tr> <tr><td>3 PLACES</td><td>±----</td><td>±0.005</td></tr> <tr><td>2 PLACES</td><td>±0.13</td><td>±0.01</td></tr> <tr><td>1 PLACE</td><td>±0.25</td><td>±0.02</td></tr> <tr><td>0 PLACES</td><td>±----</td><td>±----</td></tr> </table>			mm	INCH	4 PLACES	±----	±----	3 PLACES	±----	±0.005	2 PLACES	±0.13	±0.01	1 PLACE	±0.25	±0.02	0 PLACES	±----	±----	EC NO: 708673 DRWN: SANTHN 2022/05/20 CHK'D: SANTHN 2022/06/21 APPR: GGA 2022/06/22
			mm	INCH																	
	4 PLACES		±----	±----																	
3 PLACES	±----	±0.005																			
2 PLACES	±0.13	±0.01																			
1 PLACE	±0.25	±0.02																			
0 PLACES	±----	±----																			
DRAFT WHERE APPLICABLE MUST REMAIN WITHIN DIMENSIONS THIRD ANGLE PROJECTION	INITIAL REVISION: DRWN: HRUIZ01 2014/09/04 APPR: JFMURPHY 2015/03/23	DOCUMENT NUMBER: SD-130095-107 DOC TYPE/DOC PART/REVISION: PSD 001 A1																			
MATERIAL NUMBER: SEE TABLE CUSTOMER: GENERAL MARKET SHEET NUMBER: 1 OF 1	DRAWING: C-SIZE SERIES: 130095																				