

PAD	CONNECTION
1	Enable / disable or Not connected
2	Not connected
3	Ground
4	Output 1
5	Output 2
6	Supply

## Features

- ▶ Differential outputs
- ▶ Low phase jitter
- ▶ Enable / disable tristate option
- ▶ Fast rise / fall times
- ▶ Designed for SONET, SDH, IEEE1394 etc

## Specifications

Parameters	Variant		Option Codes
	L	J	
Frequency range:	40.0 ~ 200MHz		
Frequency stability*:	±100ppm	±50ppm	B
	±50ppm	±25ppm	A
Operating temperature range:	-10 to +70°C	-40 to +85°C	I
	-40 to +85°C		
Storage temperature range:	-40 to +85°C		
Supply voltage (V <sub>DD</sub> ):	+3.3V (±5%)	+2.5V (±5%)	
Supply current:	90mA max, 60mA typ		
Output:	Complementary LV-PECL		
Output load:	50Ω (into V <sub>DD</sub> -2V)		
Logic levels:	'0' level (max) '1' level (min)	1.745V 2.215V	1.195V 1.415V
Start up time:	10ms max		
Waveform symmetry:	45:55 max @ 50%V <sub>p-p</sub> 40:60 max @ 50%V <sub>p-p</sub>		
Rise / fall time:	1.0ns max (20 ~ 80%V <sub>p-p</sub> )		
Enable / disable function:	Tristate (control via pad 1) None (pad 1 not connected)		N
Output enable / disable time:	2ms / 200ns max		
Stand-by current:	30μA max		
Phase jitter RMS:	1ps max (0.3ps typ), 12kHz~20MHz		
Ageing:	±5ppm max, 1st year		

■ Standard. □ Optional - Please specify required code(s) when ordering

\* Frequency stability is inclusive of calibration @ 25°C, operating temperature range, supply voltage change and load change.

## Ordering Information

Product name + variant + option codes (if any) + frequency  
 eg: **GXO-E72L 108.0MHz** 3.3V, ±100ppm -10+70°C  
**GXO-E72J/BI 125.0MHz** 2.5V, ±50ppm -40+85°C  
 Option code X (eg GXO-E72L/X) denotes a custom spec.

## Enable / Disable Function

Input (pad 1)	Output 1 (pad 4)	Output 2 (pad 5)
Open '1' level (≥0.7V <sub>DD</sub> ) '0' level (≤0.3V <sub>DD</sub> )	Enabled Enabled High Impedance	Enabled Enabled High Impedance

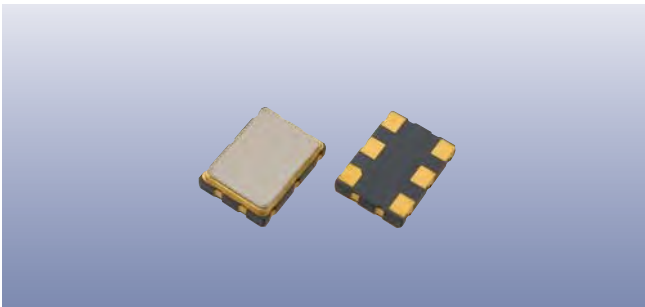

## Construction

- ▮ Ceramic body with gold-plated pads
- ▮ Metal lid, seam sealed

## Composition



This product is lead-free, and is fully compliant with the RoHS 2 directive 2011/65/EU



## Packaging & Handling

Production quantities supplied on T&R, 1k pcs per reel.  
Small quantities may be supplied on tape (no reel), or in bulk.



◆ Static sensitive product. Observe proper handling precautions

## Marking

FREQUENCY DC  
• PARTNO

• Pin 1  
Marking type: Laser  
DC = Date code in YM, eg "CE" = May 2013

	A	B	C	D	E	F	G	H	J	K	L	M
Y	1	2	3	4	5	6	7	8	9	0		
M	Jan	Feb	Mar	Apr	May	Jun	Jul	Aug	Sep	Oct	Nov	Dec

## Tape & Reel Specification

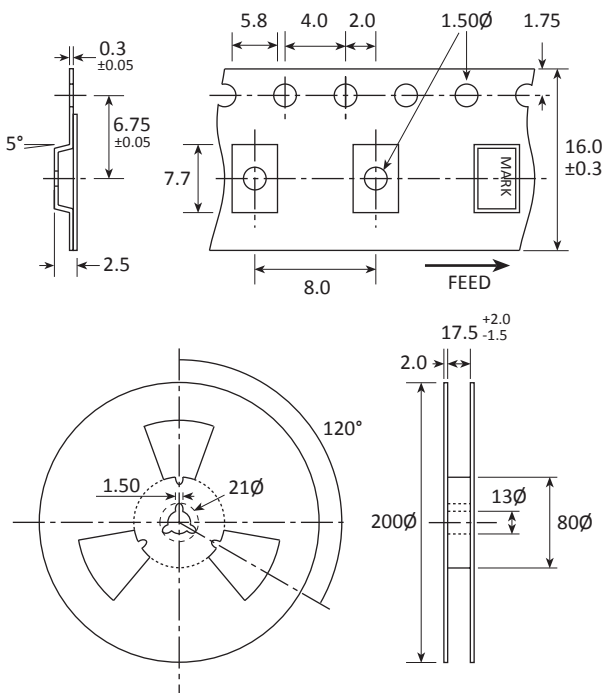

Not to scale. Dimensions in mm. Tolerances  $\pm$ 0.1mm unless otherwise stated.

## Soldering Profile

