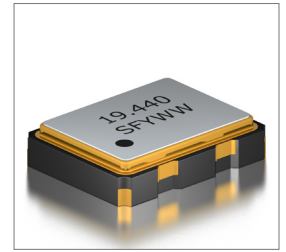
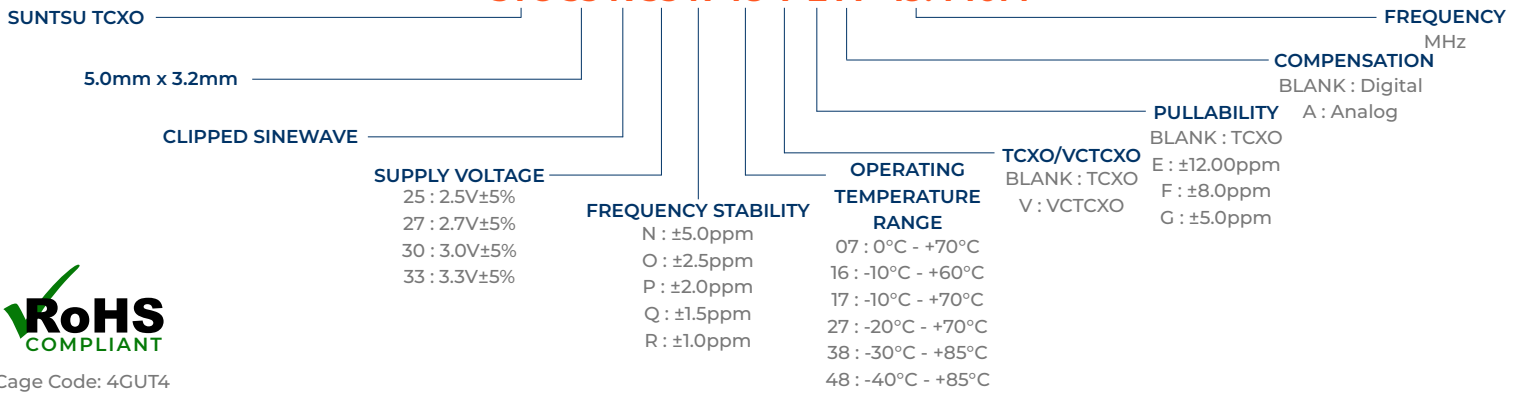

Features
<ul style="list-style-type: none"> ±1.0ppm (Frequency Stability) Available Clipped Sinewave (VC)TCXO Tape and Reel

Applications
<ul style="list-style-type: none"> Base Stations IP Networking Cellular and Cordless Phones

Part Numbering Guide
STC 53 K 33 R 48 V E A - 19.440M

Cage Code: 4GUT4

To customize your parameters contact a Suntsu representative.

Electrical Parameters	Units	Minimum	Typical	Maximum	Remarks
Frequency Range	MHz	6		40	
Frequency Tolerance at +25°C	ppm	-1.5		+1.5	1 Hour after reflow
Freq. Stability vs. Op Temp.	ppm	-1.0		+1.0	See part numbering guide for options.
Freq. Stability vs. Supply Voltage	ppm	-0.3		+0.3	V _{DD} ±5% change.
Freq. Stability vs. Load	ppm	-0.2		+0.2	±5% change
Freq. Stability vs. Aging	ppm	-1.0		+1.0	1 Year, ±3.1ppm for 10 Years
Operating Temperature	°C	-40		+85	See part numbering guide for options.
Storage Temperature	°C	-55		+125	
Supply Voltage (V _{DD})	V	3.135	3.3	3.465	See part numbering guide for options.
Current (I _{DD})	mA			2	
Control Current (VC, VCTCXO)	V	0		V _{DD}	Center Voltage : V _{DD} *50%
Pullability (VCTCXO)	ppm	±5.0		±12.0	See part numbering guide for options.
Linearity (VCTCXO)	%			10	
Output Load (Clipped Sinewave)	kΩ//pF			10//10	
Output Logic Levels	V _{P-P}	0.8			
Symmetry (Duty Cycle)	%	40	50	60	
Start-Up Time	ms			3	
VC Input Impedance (VCTCXO)	kΩ	100			
Phase Noise (Typical) 10Hz Offset	dBc/Hz		-85		
Phase Noise (Typical) 100Hz Offset	dBc/Hz		-115		
Phase Noise (Typical) 1KHz Offset	dBc/Hz		-135		
Phase Noise (Typical) 10KHz Offset	dBc/Hz		-145		
Phase Noise (Typical) 100KHz Offset	dBc/Hz		-150		

Outline Drawing

All dimensions are in millimeters (mm) unless otherwise noted. Drawings are not to scale.

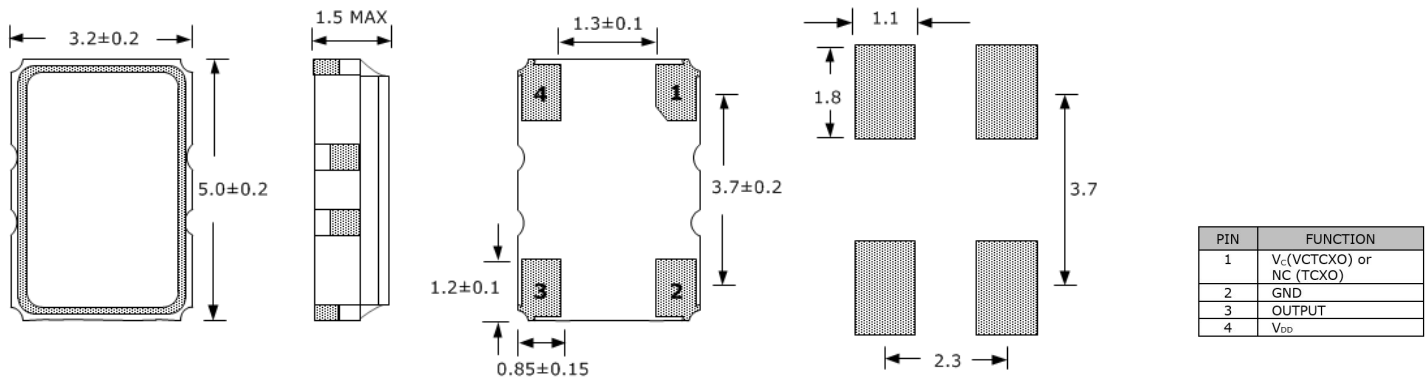

Test Circuit (Clipped Sinewave)

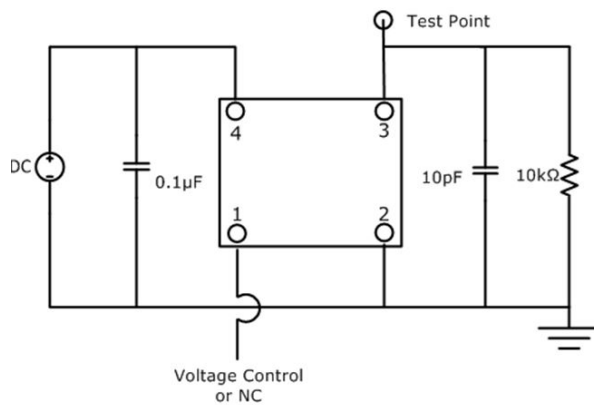

Waveform (Clipped Sinewave)

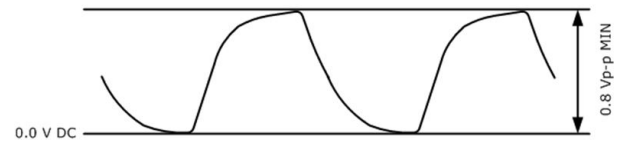

Typical Phase Noise (Measured By Agilent E5052A)

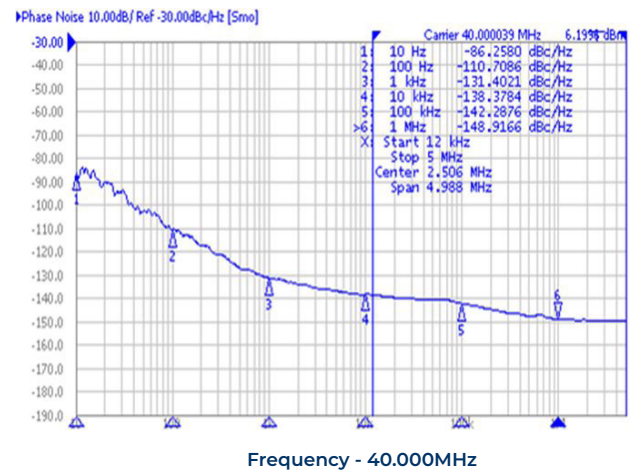
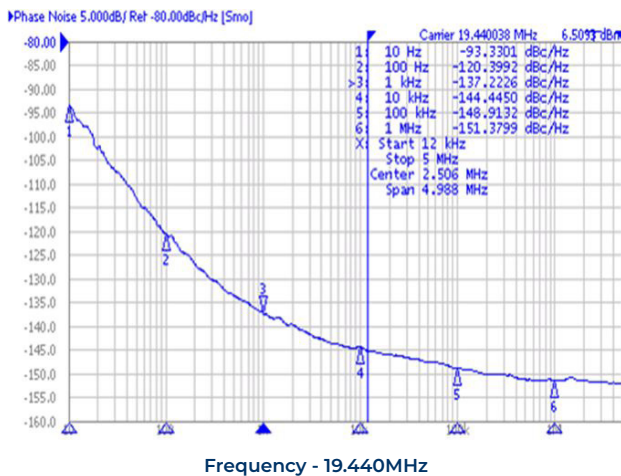

Jitter Performance (Measured By Agilent E5052A)

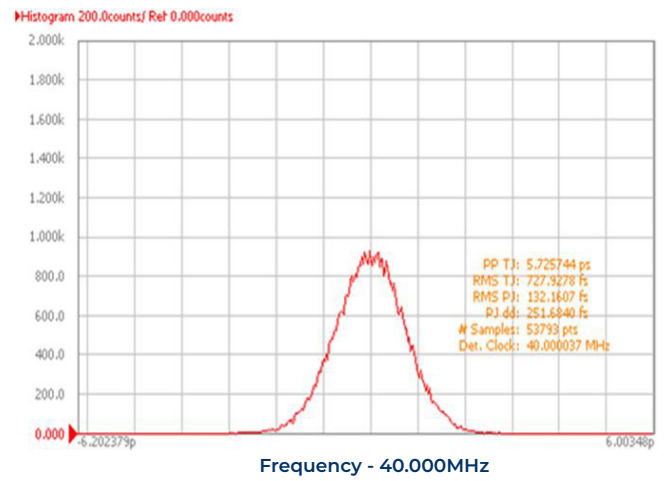
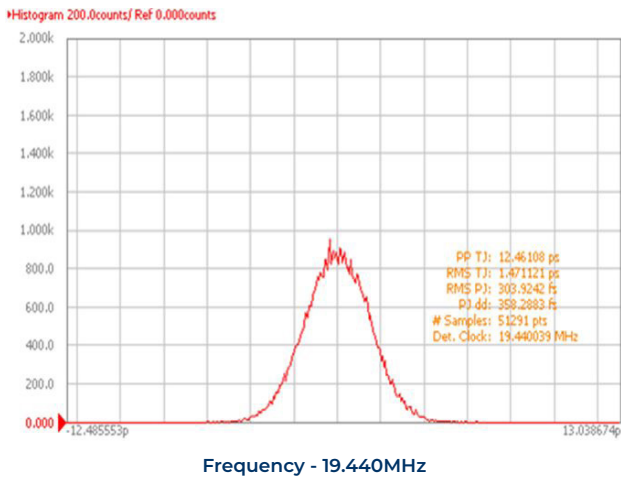

Tape And Reel Dimensions

All dimensions are in millimeters (mm) unless otherwise noted. Drawings are not to scale.

3,000pcs/Reel

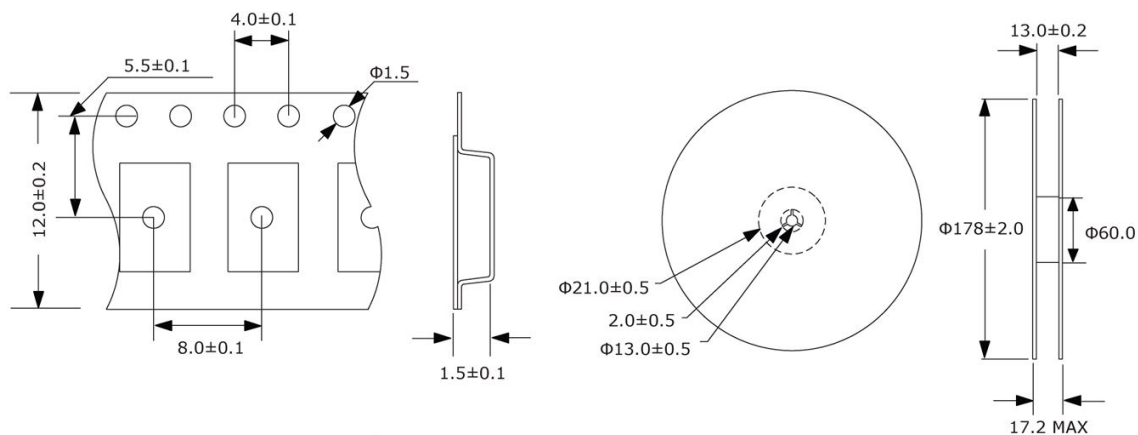

Reflow Profile & Part Marking

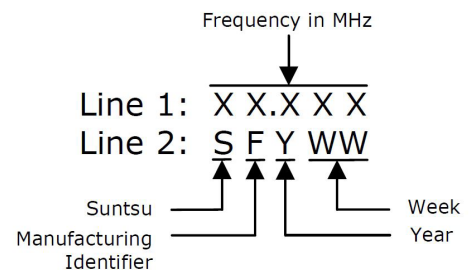
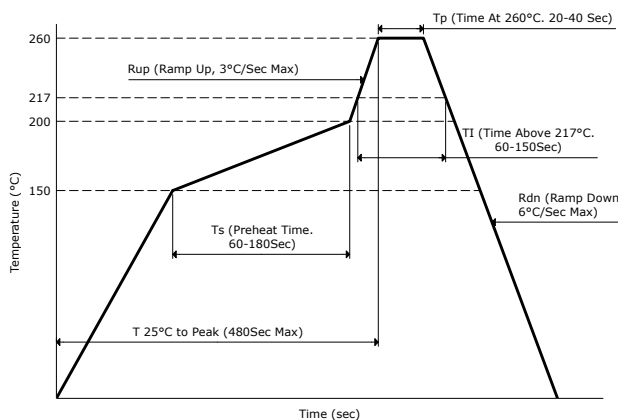

Environmental Specifications		Mechanical Specifications	
Temperature Cycling	MIL-STD-883, Method 1010, Condition B	Mechanical Shock	MIL-STD-202, Method 213, Condition B
Fine Leak Test	MIL-STD-883, Method 1014, Condition A	Vibration	MIL-STD-883, Method 2007, Condition A
Gross Leak Test	MIL-STD-883, Method 1014, Condition C	Moisture Resistance	MIL-STD-883, Method 1004
Solderability	MIL-STD-883, Method 2003	Resistance to Solvents	MIL-STD-202, Method 215
Moisture Sensitivity	J-STD-020, MSL 1	Resistance to Soldering Heat	MIL-STD-202, Method 210, Condition K