

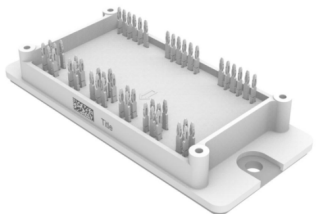
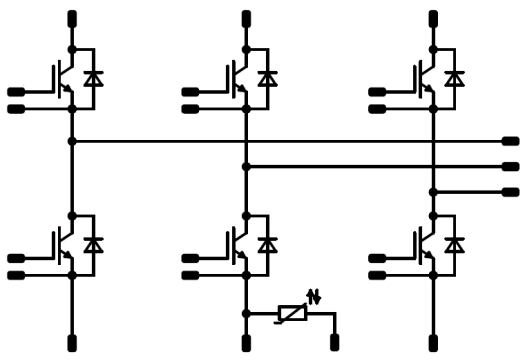

Vincotech

<i>flow</i> PACK 2	1200 V / 75 A
<div style="background-color: #eee; padding: 2px; margin-bottom: 5px;">Features</div> <ul style="list-style-type: none"> IGBT4 (1200V) technology for low saturation losses and improved EMC behavior Compact and low inductive design Integrated temperature sensor 	<div style="background-color: #eee; padding: 2px; margin-bottom: 5px;">flow 2 17mm housing</div> 
<div style="background-color: #eee; padding: 2px; margin-bottom: 5px;">Target applications</div> <ul style="list-style-type: none"> Industrial drives 	<div style="background-color: #eee; padding: 2px; margin-bottom: 5px;">Schematic</div> 
<div style="background-color: #eee; padding: 2px; margin-bottom: 5px;">Types</div> <ul style="list-style-type: none"> 30-P2126PA075SC-L288F09Y 	

Maximum Ratings

$T_j=25^\circ\text{C}$, unless otherwise specified

Parameter	Symbol	Condition	Value	Unit
Inverter Switch				
Collector-emitter voltage	V_{CES}		1200	V
Collector current	I_C	$T_j=T_{jmax}$ $T_s=80^\circ\text{C}$	85	A
Repetitive peak collector current	I_{CRM}	t_p limited by T_{jmax}	225	A
Total power dissipation	P_{tot}	$T_j=T_{jmax}$ $T_s=80^\circ\text{C}$	232	W
Gate-emitter voltage	V_{GES}		± 20	V
Maximum Junction Temperature	T_{jmax}		175	$^\circ\text{C}$



Vincotech

Parameter	Symbol	Conditions	Value	Unit
Inverter Diode				
Peak Repetitive Reverse Voltage	V_{RRM}		1200	V
Continuous (direct) forward current	I_F	$T_j=T_{jmax}$ $T_h=80^{\circ}C$	85	A
Repetitive peak forward current	I_{FRM}		150	A
Total power dissipation	P_{tot}	$T_j=T_{jmax}$ $T_h=80^{\circ}C$	154	W
Maximum Junction Temperature	T_{jmax}		175	$^{\circ}C$

Module Properties

Parameter	Symbol	Conditions	Value	Unit
Thermal Properties				
Storage temperature	T_{stg}		-40...+125	$^{\circ}C$
Operation Junction Temperature	T_{jop}		$-40...+(T_{jmax} - 25)$	$^{\circ}C$

Isolation Properties

Isolation voltage	V_{isol}	DC voltage	$t_p=2s$	4000	V
Creepage distance				min 12,7	mm
Clearance				min 12,7	mm
Comparative Tracking Index	CTI			>200	



Vincotech

Characteristic Values

Inverter Switch

Parameter	Symbol	Conditions					Value			Unit
		V_{GE} [V]	V_{CE} [V]	I_C [A]	T_j [°C]	Min	Typ	Max		

Static

Gate-emitter threshold voltage	$V_{GE(th)}$	$V_{GE}=V_{CE}$			0,0026	25 125	5,3	5,8	6,3	V
Collector-emitter saturation voltage	V_{CEsat}		15		75	25 125 150	1,58	1,92 -	2,07	V
Collector-emitter cut-off current	I_{CES}		0	1200		25 125			1	μA
Gate-emitter leakage current	I_{GES}		20	0		25 125			120	nA
Internal gate resistance	r_g							10		Ω
Input capacitance	C_{ies}	f=1 MHz	0	25		25		4300		pF
Reverse transfer capacitance	C_{res}							160		

Thermal

Thermal resistance junction to sink	$R_{th(j-s)}$	Phase-Change Material $\lambda=3,4W/mK$						0,41		K/W
-------------------------------------	---------------	--	--	--	--	--	--	------	--	-----

IGBT Switching

Turn-on delay time	$t_{d(on)}$	$R_{goff} = 4 \Omega$ $R_{gon} = 4 \Omega$	±15	600	75	25		178		ns
Rise time	t_r					150		196		
Turn-off delay time	$t_{d(off)}$					25		34		
Fall time	t_f					150		36		
Turn-on energy (per pulse)	E_{on}	$Q_{rFWD} = 6,6 \mu C$ $Q_{rFWD} = 14,1 \mu C$				25		6,174	mWs	
Turn-off energy (per pulse)	E_{off}					150		9,393		
						25		4,009		
						150		6,991		



Vincotech

Inverter Diode

Parameter	Symbol	Conditions					Value			Unit
				V_r [V]	I_F [A]	T_j [°C]	Min	Typ	Max	

Static

Forward voltage	V_F				75	25 125 150		1,75 - 1,72	2,05	V
Reverse leakage current	I_r			1200		25 150			14 -	μ A

Thermal

Thermal resistance junction to sink	$R_{th(j-s)}$	Phase-Change Material $\lambda=3,4\text{W/mK}$						0,62		K/W
-------------------------------------	---------------	---	--	--	--	--	--	------	--	-----

FWD Switching

Peak recovery current	I_{RRM}	$di/dt = 2443\text{ A}/\mu\text{s}$ $dj/dt = 2277\text{ A}/\mu\text{s}$	± 15	600	75	25		69		A
Reverse recovery time	t_{rr}					150		86		ns
Recovered charge	Q_r					25		275		μ C
Reverse recovered energy	E_{rec}					150		457		mWs
Peak rate of fall of recovery current	$(di_{rr}/dt)_{max}$					25		6,624		μ s
		150		14,075						
		25		2,287						
		150		5,224						
		25		1859						
		150		724						

Thermistor

Parameter	Symbol	Conditions					Value			Unit
				V_{CE} [V]	V_{CE} [V]	I_C [A]	T_j [°C]	Min	Typ	

Rated resistance	R					25		22		k Ω
Deviation of R100	$\Delta_{R/R}$	R100=1486 Ω				100	-12		+12	%
Power dissipation	P					25		200		mW
Power dissipation constant						25		2		mW/K
B-value	$B_{(25/50)}$	Tol. $\pm 3\%$				25		3950		K
B-value	$B_{(25/100)}$	Tol. $\pm 3\%$				25		3998		K
Vincotech NTC Reference									B	



Inverter Switch Characteristics

Typical output characteristics IGBT

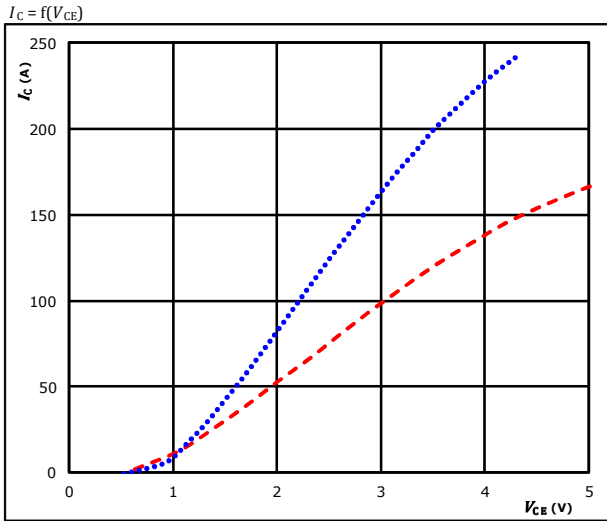

$t_p = 250 \mu s$
 $V_{GE} = 15 V$
 25 °C
 125 °C
 150 °C

Typical output characteristics IGBT

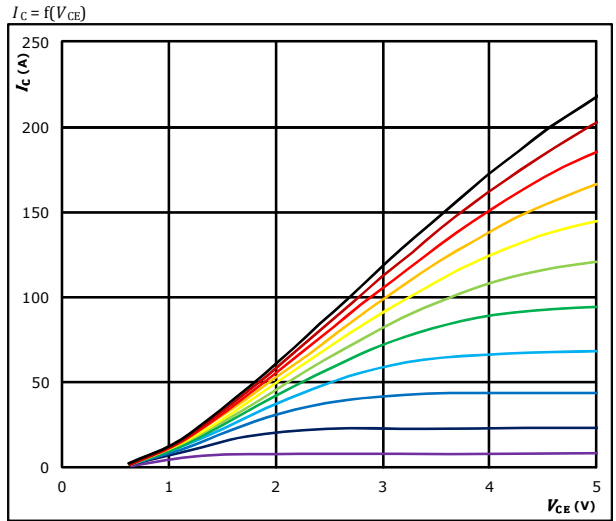

$t_p = 250 \mu s$
 $T_j = 150 \text{ } ^\circ C$
 V_{GE} from 7 V to 17 V in steps of 1 V

Typical transfer characteristics IGBT

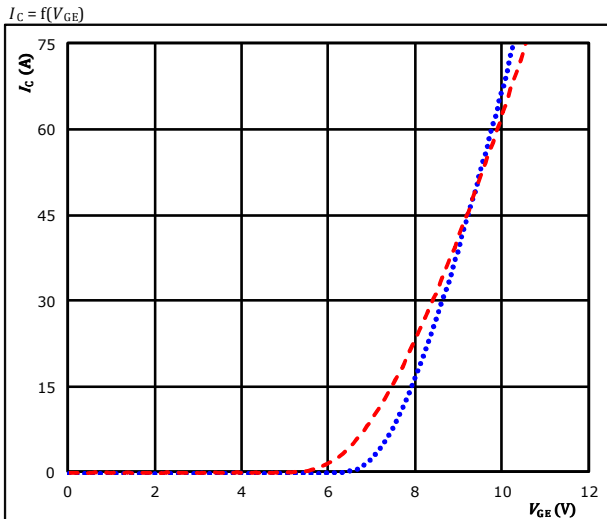

$t_p = 100 \mu s$
 $V_{CE} = 10 V$
 25 °C
 125 °C
 150 °C

Transient Thermal Impedance as function of Pulse duration IGBT

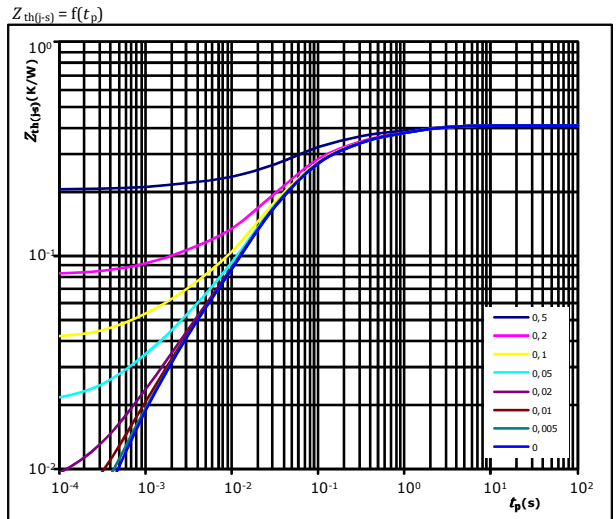

$D = t_p / T$
 $R_{th(j-s)} = 0,41 \text{ K/W}$
 IGBT thermal model values

R_{th} (K/W)	τ (s)
6,08E-02	1,41E+00
9,91E-02	1,99E-01
1,78E-01	4,61E-02
5,03E-02	1,41E-02
2,16E-02	1,42E-03



Inverter Diode Characteristics

Typical forward characteristics FWD

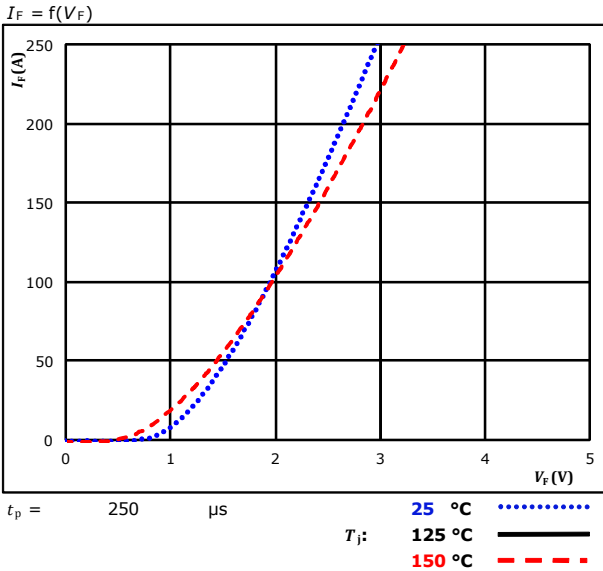

Transient thermal impedance as a function of pulse width FWD

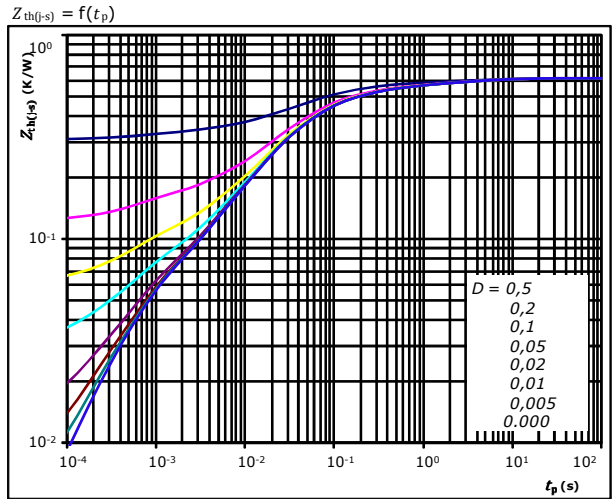

$D = t_p / T$
 $R_{th(j-s)} = 0,62 \text{ K/W}$

FWD thermal model values

R (K/W)	τ (s)
4,36E-02	4,66E+00
7,48E-02	5,44E-01
1,95E-01	8,13E-02
2,13E-01	2,26E-02
4,51E-02	5,48E-03
4,51E-02	5,92E-04

Thermistor Characteristics

Thermistor typical temperature characteristic

Typical NTC characteristic as a function of temperature

$R_T = f(T)$

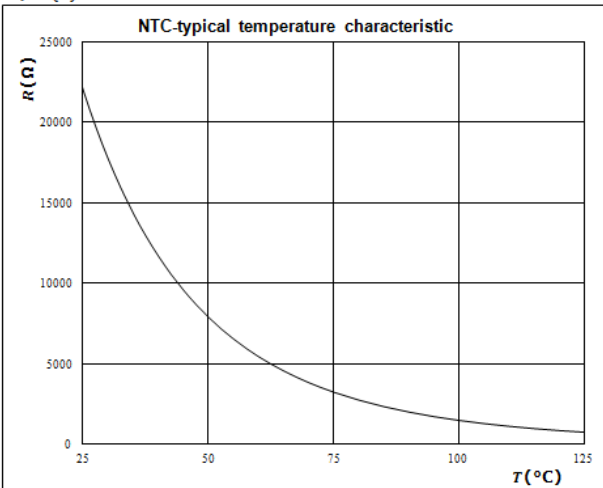



Inverter Switching Characteristics

Figure 1. IGBT
Typical switching energy losses as a function of collector current

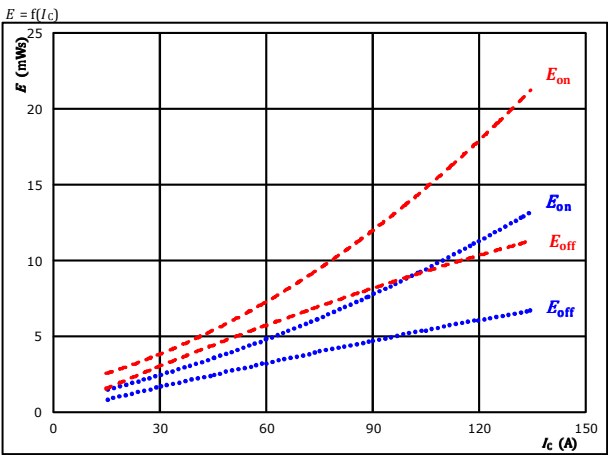

With an inductive load at
 $V_{CE} = 600$ V
 $V_{GE} = \pm 15$ V
 $R_{gpn} = 4$ Ω
 $R_{goff} = 4$ Ω
 T_j : 25 °C (blue dotted), 125 °C (black solid), 150 °C (red dashed)

Figure 2. IGBT
Typical switching energy losses as a function of gate resistor

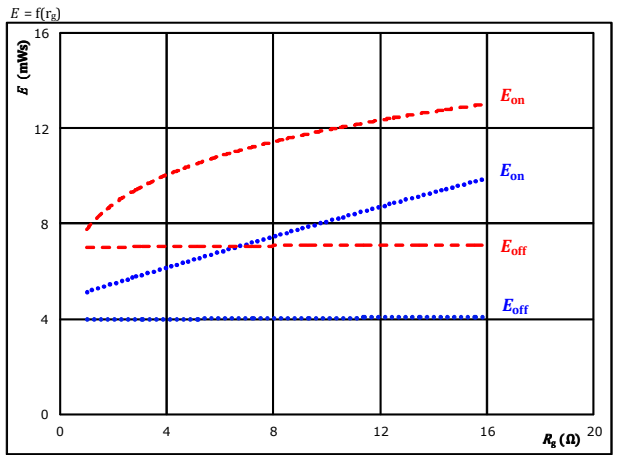

With an inductive load at
 $V_{CE} = 600$ V
 $V_{GE} = \pm 15$ V
 $I_C = 75$ A
 T_j : 25 °C (blue dotted), 125 °C (black solid), 150 °C (red dashed)

Figure 3. FWD
Typical reverse recovered energy loss as a function of collector current

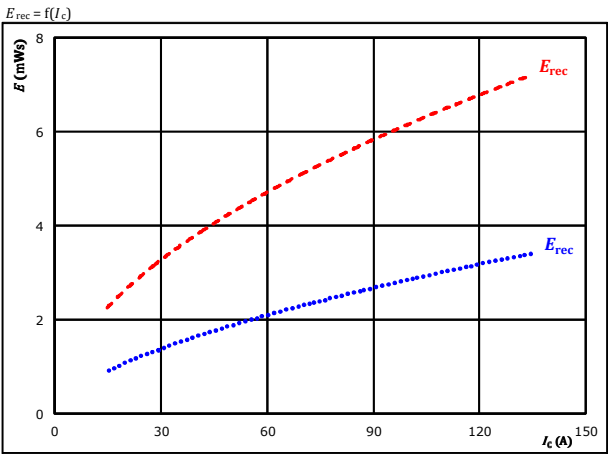

With an inductive load at
 $V_{CE} = 600$ V
 $V_{GE} = \pm 15$ V
 $R_{gpn} = 4$ Ω
 T_j : 25 °C (blue dotted), 125 °C (black solid), 150 °C (red dashed)

Figure 4. FWD
Typical reverse recovered energy loss as a function of gate resistor

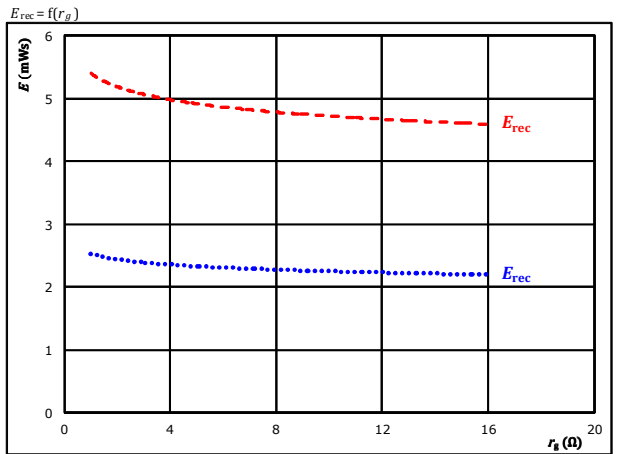

With an inductive load at
 $V_{CE} = 600$ V
 $V_{GE} = \pm 15$ V
 $I_C = 75$ A
 T_j : 25 °C (blue dotted), 125 °C (black solid), 150 °C (red dashed)



Inverter Switching Characteristics

Figure 5. IGBT

Typical switching times as a function of collector current

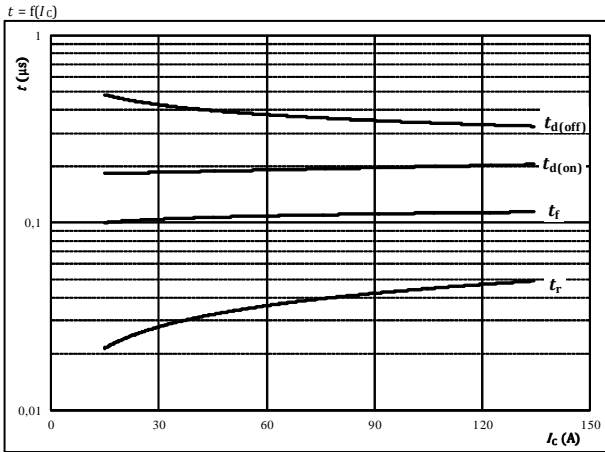

With an inductive load at

$T_j = 150$ °C
 $V_{CE} = 600$ V
 $V_{GE} = \pm 15$ V
 $R_{g(on)} = 4$ Ω
 $R_{g(off)} = 4$ Ω

Figure 6. IGBT

Typical switching times as a function of gate resistor

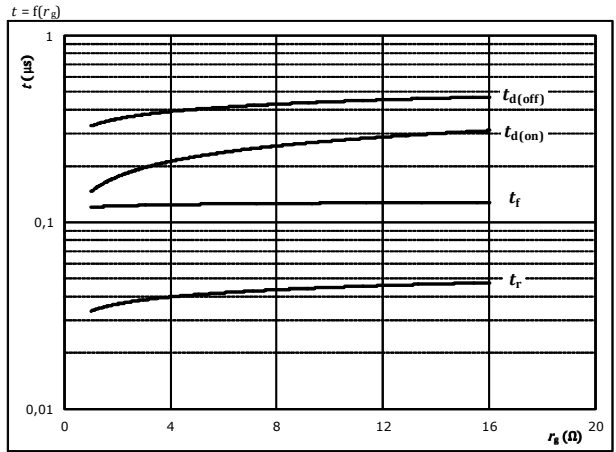

With an inductive load at

$T_j = 150$ °C
 $V_{CE} = 600$ V
 $V_{GE} = \pm 15$ V
 $I_c = 75$ A

Figure 7. FWD

Typical reverse recovery time as a function of collector current

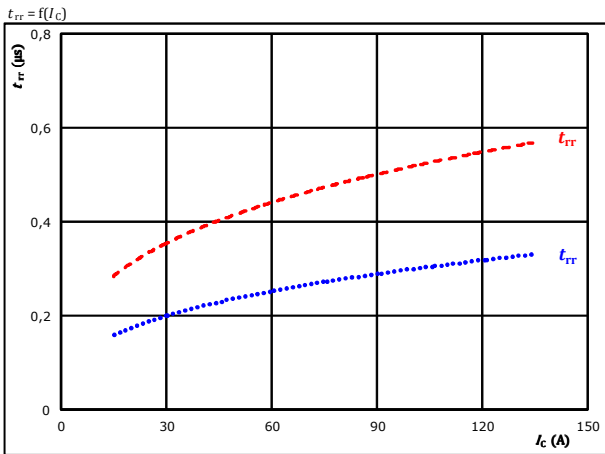

At $V_{CE} = 600$ V
 $V_{GE} = \pm 15$ V
 $R_{g(on)} = 4$ Ω
 T_j : 25 °C (dotted blue line)
 125 °C (solid black line)
 150 °C (dashed red line)

Figure 8. FWD

Typical reverse recovery time as a function of IGBT turn on gate resistor

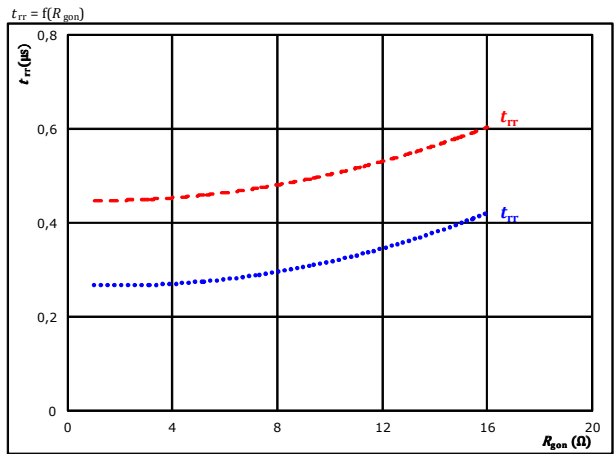

At $V_{CE} = 600$ V
 $V_{GE} = \pm 15$ V
 $I_c = 75$ A
 T_j : 25 °C (dotted blue line)
 125 °C (solid black line)
 150 °C (dashed red line)



Inverter Switching Characteristics

Figure 9. FWD

Typical recovered charge as a function of collector current

$$Q_r = f(I_c)$$

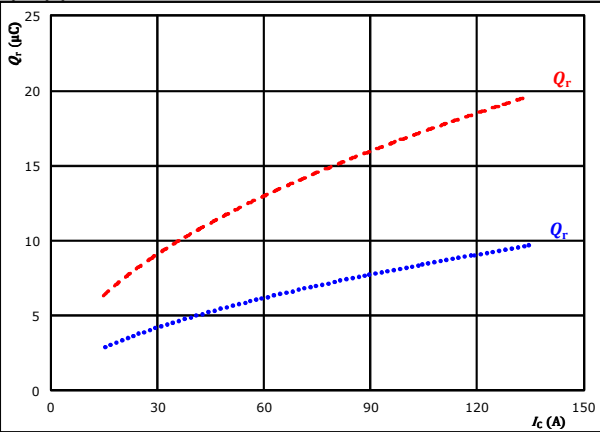

At $V_{CE} = 600$ V
 $V_{GE} = \pm 15$ V
 $R_{gdn} = 4$ Ω
 T_j : 25 °C (blue dotted line)
 125 °C (black solid line)
 150 °C (red dashed line)

Figure 10. FWD

Typical recovered charge as a function of IGBT turn on gate resistor

$$Q_r = f(R_{gdn})$$

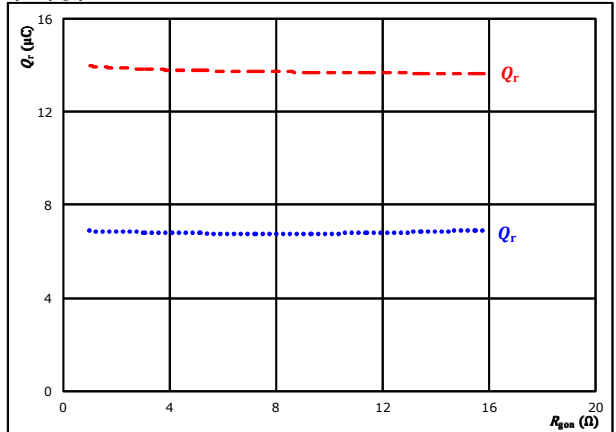

At $V_{CE} = 600$ V
 $V_{GE} = \pm 15$ V
 $I_c = 75$ A
 T_j : 25 °C (blue dotted line)
 125 °C (black solid line)
 150 °C (red dashed line)

Figure 11. FWD

Typical peak reverse recovery current as a function of collector current

$$I_{RM} = f(I_c)$$

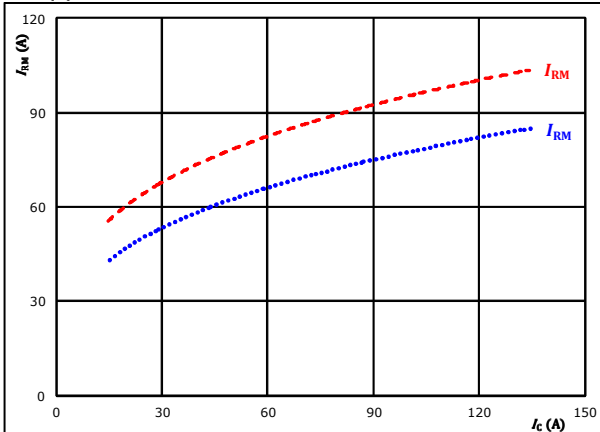

At $V_{CE} = 600$ V
 $V_{GE} = \pm 15$ V
 $R_{gdn} = 4$ Ω
 T_j : 25 °C (blue dotted line)
 125 °C (black solid line)
 150 °C (red dashed line)

Figure 12. FWD

Typical peak reverse recovery current as a function of IGBT turn on gate resistor

$$I_{RM} = f(R_{gdn})$$

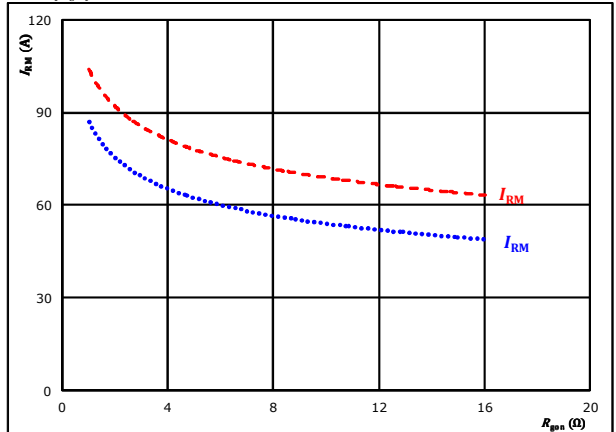

At $V_{CE} = 600$ V
 $V_{GE} = \pm 15$ V
 $I_c = 75$ A
 T_j : 25 °C (blue dotted line)
 125 °C (black solid line)
 150 °C (red dashed line)



Inverter Switching Characteristics

Figure 13. FWD

Typical rate of fall of forward and reverse recovery current as a function of collector current
 $di_F/dt, di_{rr}/dt = f(I_C)$

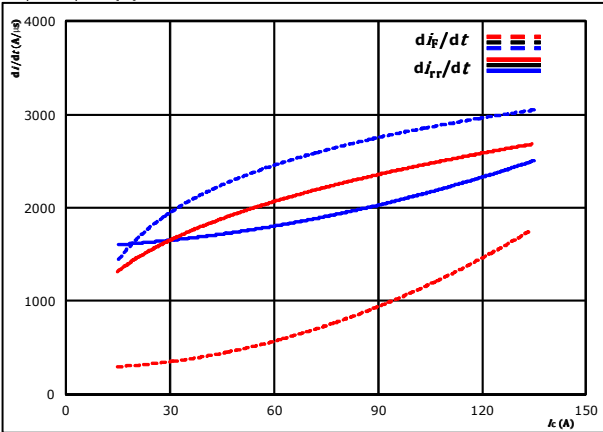

At $V_{CE} = 600$ V
 $V_{CE} = \pm 15$ V
 $R_{gon} = 4$ Ω
 $T_j = 25$ °C
 125 °C
 150 °C

Figure 14. FWD

Typical rate of fall of forward and reverse recovery current as a function of IGBT turn on gate resistor
 $di_F/dt, di_{rr}/dt = f(R_g)$

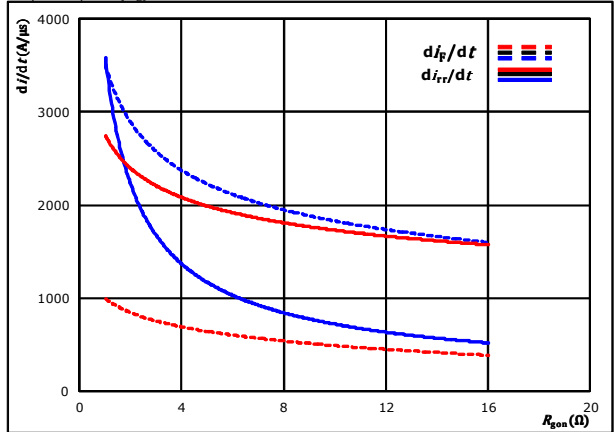

At $V_{CE} = 600$ V
 $V_{CE} = \pm 15$ V
 $I_C = 75$ A

Figure 15. IGBT

Reverse bias safe operating area

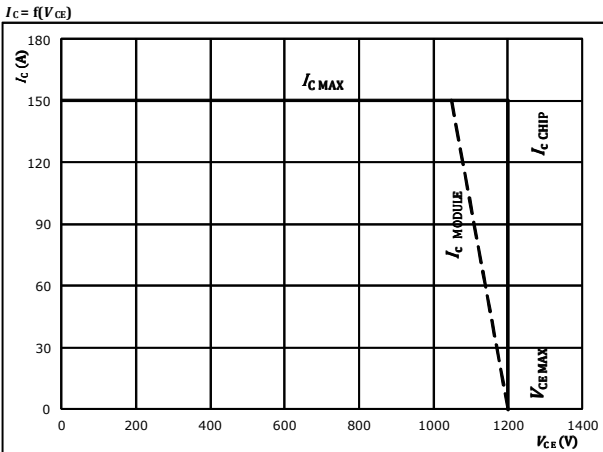

At $T_j = 175$ °C
 $R_{gon} = 4$ Ω
 $R_{goff} = 4$ Ω



Inverter Switching Definitions

Figure 1. IGBT

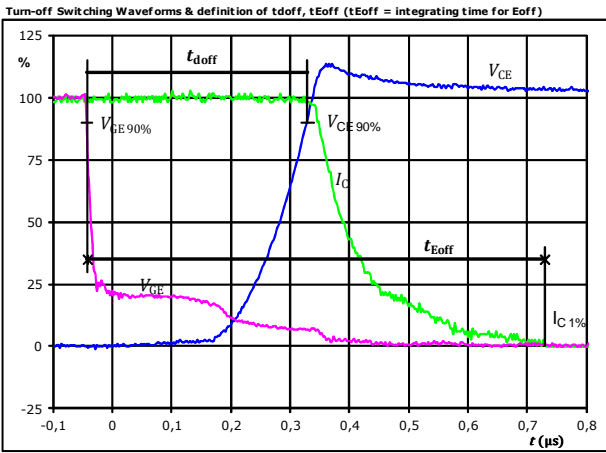

$V_{GE}(0\%) =$	-15	V
$V_{GE}(100\%) =$	15	V
$V_C(100\%) =$	600	V
$I_C(100\%) =$	75	A
$t_{doff} =$	0,373	μs
$t_{Eoff} =$	0,772	μs

Figure 2. IGBT

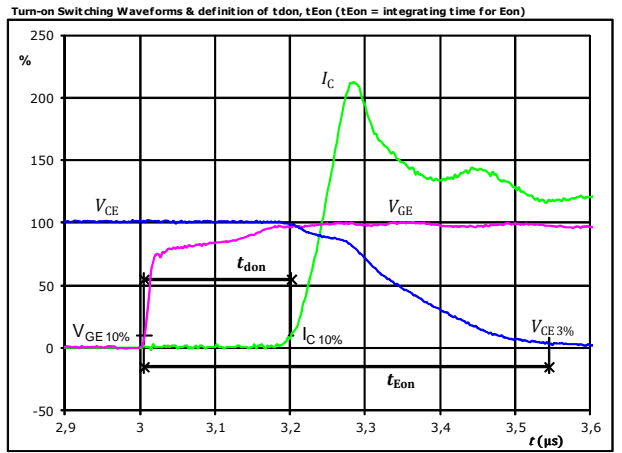

$V_{GE}(0\%) =$	-15	V
$V_{GE}(100\%) =$	15	V
$V_C(100\%) =$	600	V
$I_C(100\%) =$	75	A
$t_{don} =$	0,195	μs
$t_{Eon} =$	0,539	μs

Figure 3. IGBT

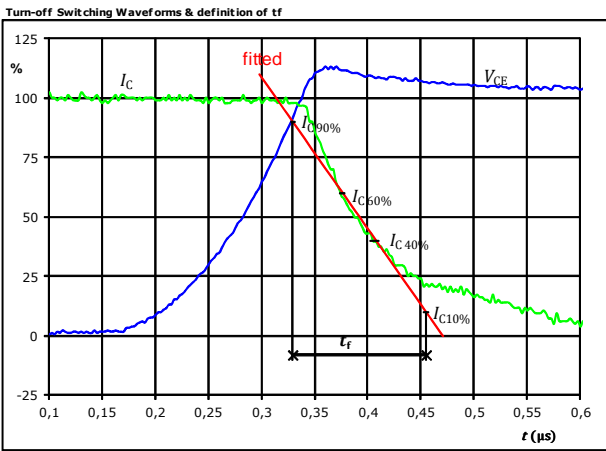

$V_C(100\%) =$	600	V
$I_C(100\%) =$	75	A
$t_f =$	0,120	μs

Figure 4. IGBT

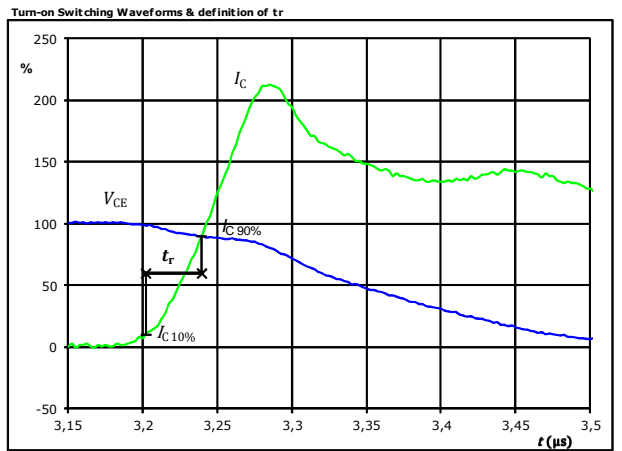

$V_C(100\%) =$	600	V
$I_C(100\%) =$	75	A
$t_r =$	0,038	μs



Inverter Switching Definitions

Figure 5. IGBT

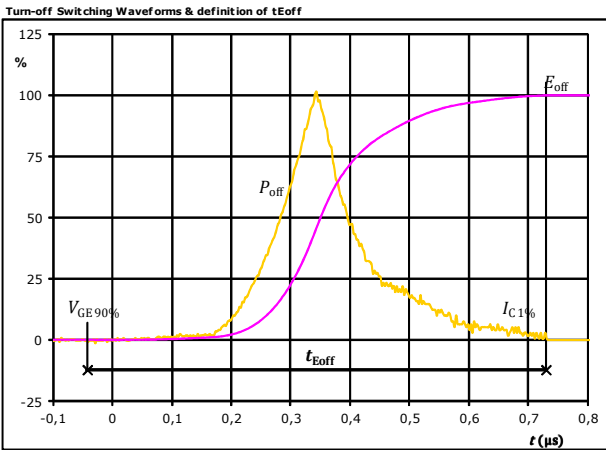

$P_{off}(100\%) =$	44,97	kW
$E_{off}(100\%) =$	7,03	mJ
$t_{Eoff} =$	0,77	µs

Figure 6. IGBT

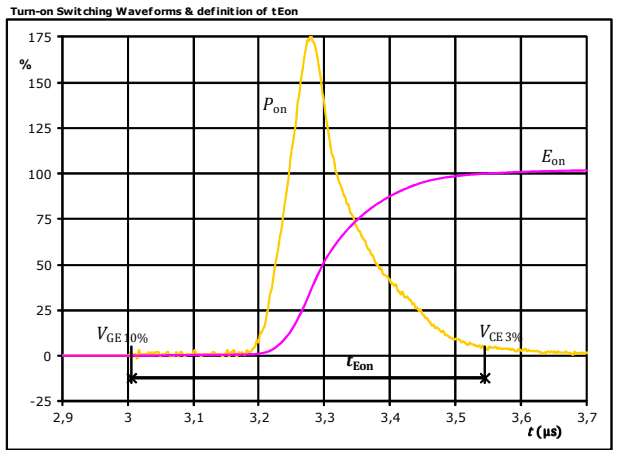

$P_{on}(100\%) =$	44,97	kW
$E_{on}(100\%) =$	9,36	mJ
$t_{Eon} =$	0,54	µs

Figure 7. FWD

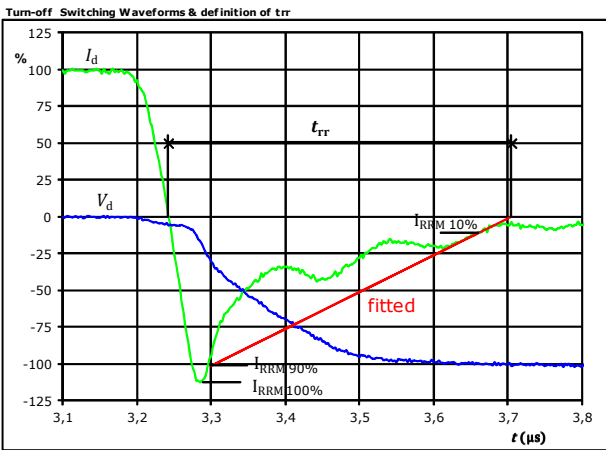

$V_d(100\%) =$	600	V
$I_d(100\%) =$	75	A
$I_{RRM}(100\%) =$	-85	A
$t_{rr} =$	0,455	µs



Inverter Switching Definitions

Figure 8. FWD

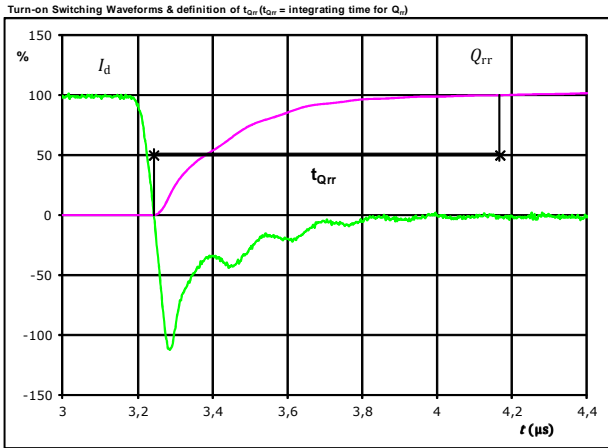

I_d (100%) =	75	A
Q_{rr} (100%) =	13,41	μC
t_{Qrr} =	0,93	μs

Figure 9. FWD

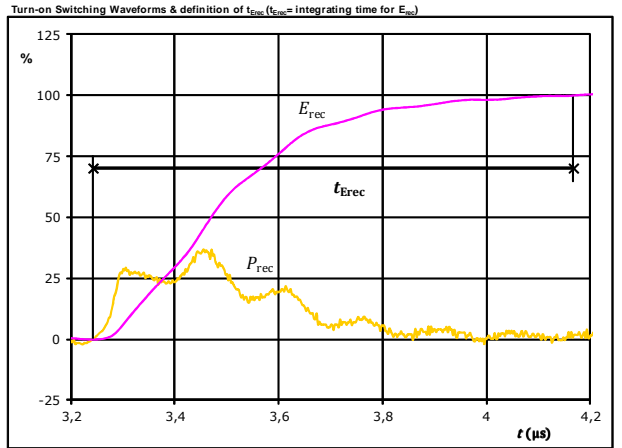

P_{rec} (100%) =	44,97	kW
E_{rec} (100%) =	4,88	mJ
t_{Erec} =	0,93	μs



Vincotech

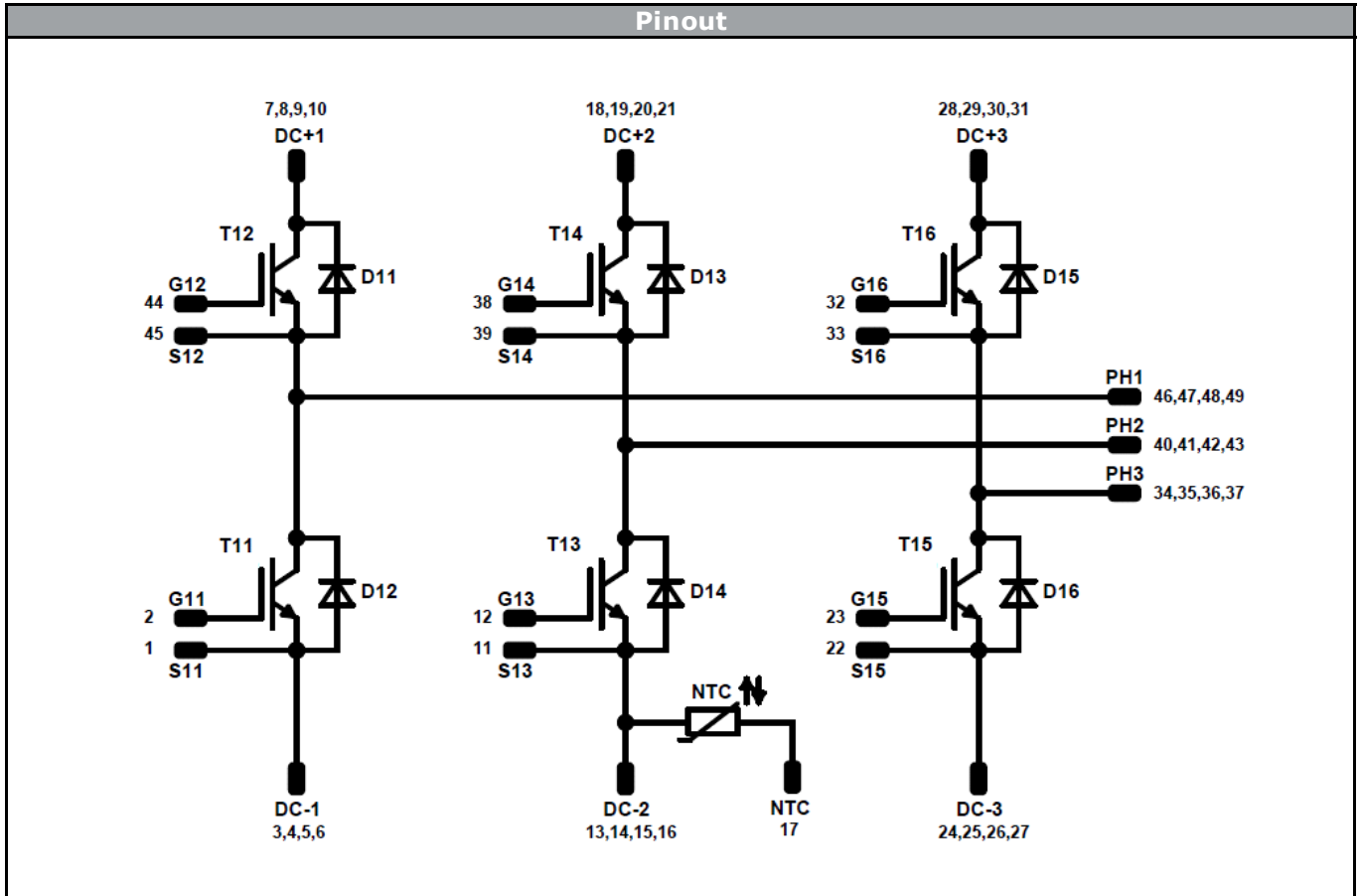

Identification					
ID	Component	Voltage	Current	Function	Comment
T11,T12,T13,T14,T15, T16	IGBT	1200V	75A	Inverter Switch	IGC70T120T8RL
D11,D12,D13,D14,D15, D16	FWD	1200V	75A	Inverter Diode	IDC40D120T6M
NTC	NTC	-	-	Thermistor	



Packaging instruction					
Standard packaging quantity (SPQ)	42	>SPQ	Standard	<SPQ	Sample

Handling instruction	
Handling instructions for <i>flow</i> 2 packages see vincotech.com website.	

Document No.:	Date:	Modification:	Pages
30-P2126PA075SC-L288F09Y-D1-14	01 Jun. 2015		

DISCLAIMER

The information, specifications, procedures, methods and recommendations herein (together "information") are presented by Vincotech to reader in good faith, are believed to be accurate and reliable, but may well be incomplete and/or not applicable to all conditions or situations that may exist or occur. Vincotech reserves the right to make any changes without further notice to any products to improve reliability, function or design. No representation, guarantee or warranty is made to reader as to the accuracy, reliability or completeness of said information or that the application or use of any of the same will avoid hazards, accidents, losses, damages or injury of any kind to persons or property or that the same will not infringe third parties rights or give desired results. It is reader's sole responsibility to test and determine the suitability of the information and the product for reader's intended use.

LIFE SUPPORT POLICY

Vincotech products are not authorised for use as critical components in life support devices or systems without the express written approval of Vincotech.

As used herein:

1. Life support devices or systems are devices or systems which, (a) are intended for surgical implant into the body, or (b) support or sustain life, or (c) whose failure to perform when properly used in accordance with instructions for use provided in labelling can be reasonably expected to result in significant injury to the user.
2. A critical component is any component of a life support device or system whose failure to perform can be reasonably expected to cause the failure of the life support device or system, or to affect its safety or effectiveness.