

RoHS

SPECIFICATIONS

Rated Current:1.5AMP  
 Contact Resistance:20mΩ Max  
 Withstand Voltage:400V AC/DC  
 Insulation Resistance:800MΩ Min  
 Operation Temperature:-40°C to +105°C

Contact Material:Brass  
 Contact Plating:Au Over Ni  
 Insulator Material:Polyester(UL94V-0)  
 Standard: PA6T  
 Max.Processing Temp: 230°C for 30-60 seconds  
 (260°C for 10 seconds)

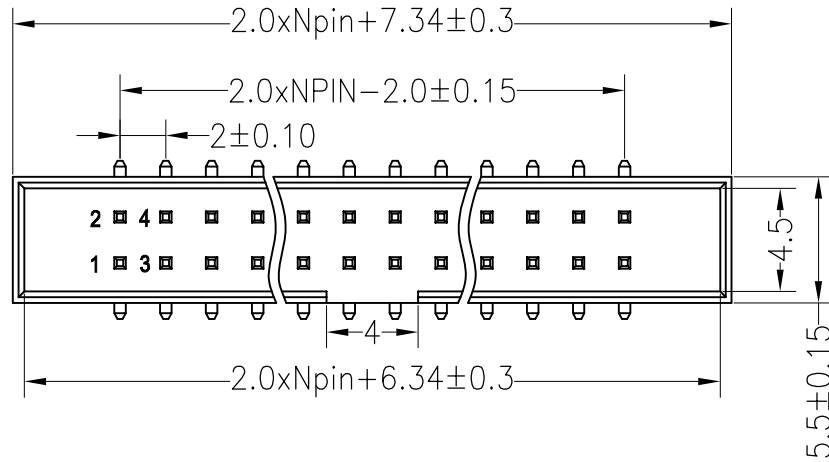

Recommended P.C.B Layout(Top Side)  
 (PCB BOARD TOLERANCE±0.05)

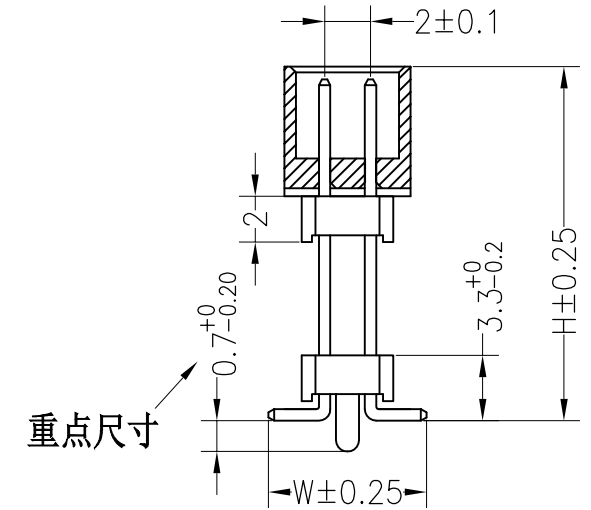
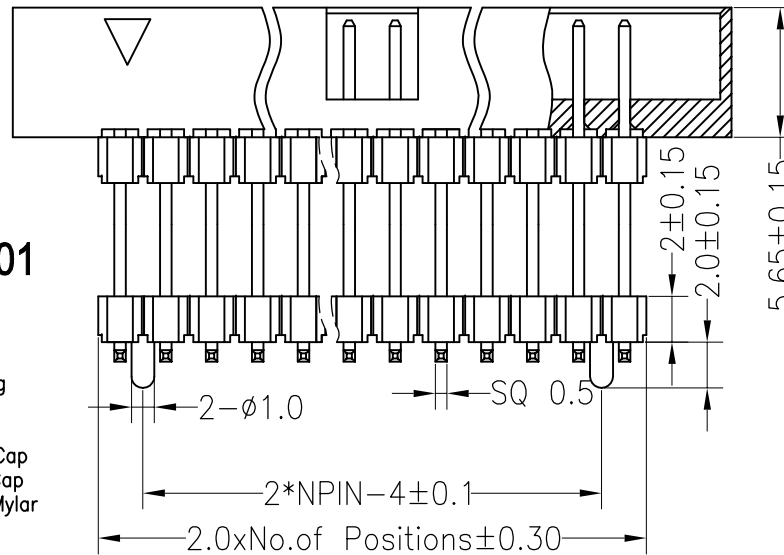
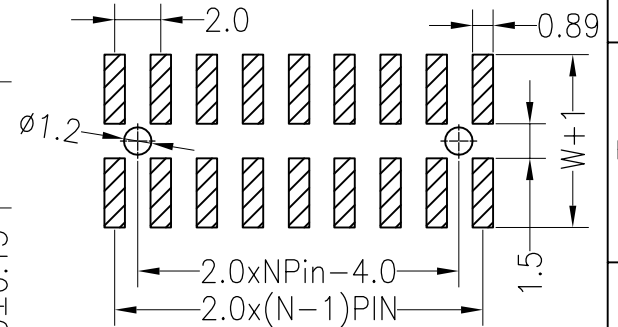

Dimension antitheses list				
ITEM	D	W	PB	L
Alternate		6.50	19.50	20.50

Ordering Information

3220- XX M XX X B D00 X 01

No.of Pins Per Row 6--64	Contact Plating G0:0.8U" Gold G1:1U" Gold G2:1.5U" Gold G3:2U" Gold G4:3U" Gold G5:5U" Gold S0:Gold Flash/Tin SN:Tin	Insulator Material Option A=BK-PBT B=BK-PA66 C=BK-PA6T D=BK-PA46 E=BK-PA9T F=BK-LCP	Packing 0=PE Bag A=Tray T=Tube P=Tube+Cap R=Reel+Cap M=Reel+Mylar
-----------------------------	--	---	---

OPERATION

X.X	±0.30
X.XX	±0.20
X.XXX	±0.10
Angle	±3°
DIM	TOL

DRAW

CHECK

APPROVE

SCALE

UNIT

SIZE

SHEET

PROJ.

FIT

mm

A4

1/1

◆

深圳市连盛精密连接器有限公司

PART NO.

BH-00050

TITLE:

2.0Box 30P 3H=5.65+2X2.00  
 SMT=6.5 总高19.5

A

REV	DATE	MODIFICATION DESCRIPTION	CHANGE
A0	2012.03.28	NEW DRAWING	