

Coaxial High Power Amplifier

ZHL-20W-202-S+

50Ω 20W 20 to 2000 MHz

The Big Deal

- Saturated power, 20W
- Wide bandwidth, 20 to 2000 MHz
- High gain, 53 dB typ.
- Self-protected from excessive drive, heat, and reverse polarity
- Withstands short and open circuit at output while delivering up to 20W



ZHL-20W-202-S+



ZHL-20W-202X-S+

Product Overview

The ZHL-20W-202-S+ is a Class AB, high-power amplifier providing 20W saturated power over the 20 to 2000 MHz band, ideal for a variety of high-power test setups as well as applications including communications, radar and more. The ruggedly-designed amplifier provides unconditional stability and built-in self-protection against reverse polarity, excessive drive and overheating. The amplifier's output stage is further protected in the event of a fault condition, allowing high power operation into an OPEN or SHORT load (refer to the maximum input power specifications). Housed in a rugged aluminum alloy case measuring 4.3 x 6.7 x 1.2", the unit features SMA connectors and an optional heat sink and fan attachment for cooling.

Key Features

Feature	Advantages
Ultra Wideband, usable from 20 to 2400 MHz	Suitable for a broad range of high-power, wideband applications, including test setups, communications and defense applications.
High gain, 53 dB	Enables signal amplification to 20W output without the need for multiple gain stages.
Built-in self-protection	In instances of potentially-damaging excessive drive current, heat buildup within the housing, unshorting of DC supply, and short or open loads at the output, an automatic sensing feature signals the unit to power down.
Unconditional stability	Provides reliable performance independent of input and load conditions.

Coaxial High Power Amplifier

ZHL-20W-202-S+

50Ω 20W 20 to 2000 MHz

Features

- High power, 20 Watt at saturation
- Class AB amplifier
- High IP3, +45 dBm typ.
- Usable from 20 MHz to 2400 MHz
- Good gain flatness, ±2.0 dB typ.
- No damage with an open or short output load while delivering up to 20W
- Shuts off when base plate temperature exceeds +85°C

Applications

- Cellular
- PCN
- GSM
- ISM
- Lab Test



Model No.	ZHL-20W-202-S+	ZHL-20W-202X-S+ [▲]
Case Style	BT1689-1	
Connectors	SMA / Solderable pins/D-Sub Male	

+RoHS Compliant

The +Suffix identifies RoHS Compliance. See our web site for RoHS Compliance methodologies and qualifications

Electrical Specifications at 25°C

Parameter	ZHL-20W-202-S+			ZHL-20W-202X-S+ [▲]			Units
	Min.	Typ.	Max.	Min.	Typ.	Max.	
Frequency Range	20		2000	20		2000	MHz
Gain ¹	44	53	56	44	53	56	dB
Gain Flatness	—	±2.0	±2.7		±2.0	±2.7	dB
Output Power at 3 dB compression	—	+39	—		+39	—	dBm
Output Power at Saturation	+42	+45	—	+42	+45	—	dBm
Noise Figure		10	—		10	—	dB
Output third order intercept point		+45	—		+45	—	dBm
Input VSWR	—	2.0	—	—	2.0	—	:1
Output VSWR	—	3.5	—	—	3.5	—	:1
DC Supply Voltage	—	28	30	—	28	30	V
Supply Current ²	—	4	7	—	4	7	A

1. Small signal input power -50 dBm typ.
2. Power Supply should be capable of delivering 4A at start up.

[▲] Heat sink and fan not included. Alternative heat sinking and heat removal must be provided by the user to limit maximum base-plate temperature to 85°C, in order to ensure proper performance. For reference, this requires thermal resistance of user's external heat sink to be 0.2°C/W max.

Maximum Ratings³

Parameter	Ratings
Operating Temperature	-20°C to 60°C
Storage Temperature	-55°C to 100°C
Base Plate Temperature	85°C
Input RF Power (no damage)	+5 dBm ⁴ -13 dBm ⁵

3. Specifications apply to CW signals only permanent damage may occur if any of these limits are exceeded.
4. Into 50 ohm load.
5. Into open or short load

Outline Drawing for models with heatsink

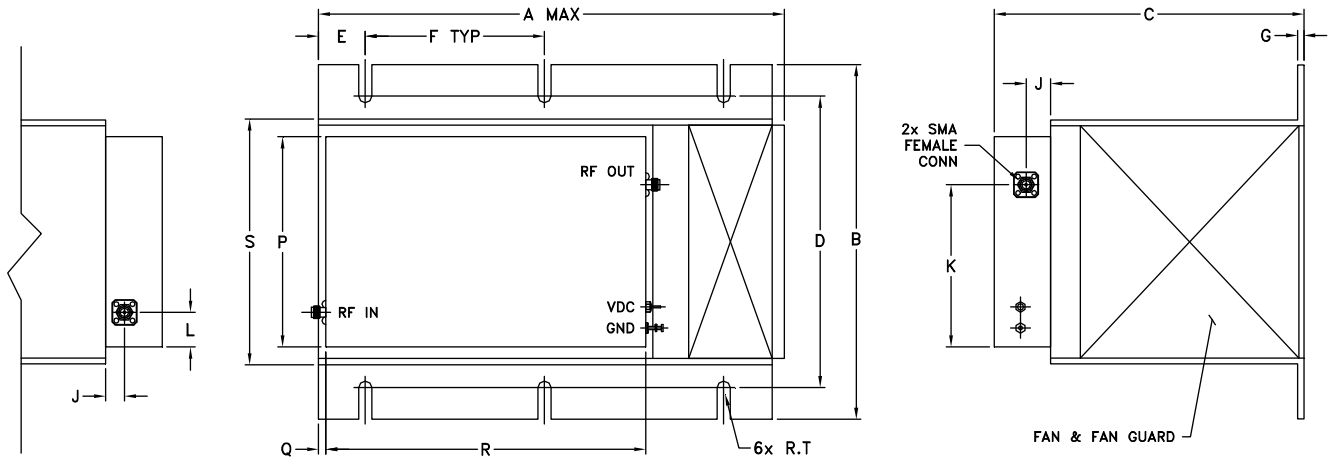

MOUNTING INFORMATION FOR MODELS WITHOUT HEATSINK

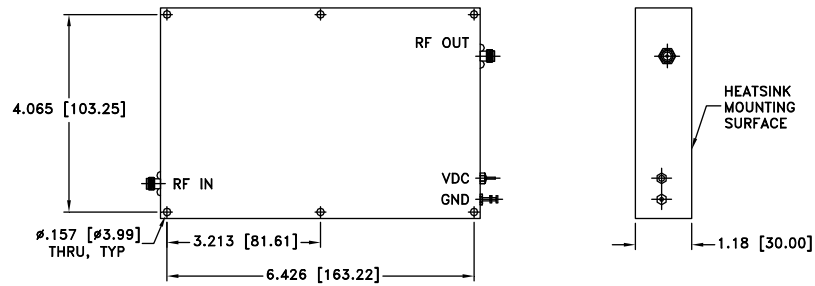

Outline Dimensions (inch / mm)

A	B	C	D	E	F	G	J	K	L	M	P	Q	R	S	T	wt
9.85	7.30	6.50	6.00	0.98	3.75	0.13	0.47	3.34	0.71	--	4.33	0.20	6.69	5.10	0.14	grams*
250.19	185.42	167.64	152.4	24.89	95.25	3.30	12.00	84.80	18.00	--	110.00	5.08	170.00	129.54	3.45	4565
																*880 grams without heatsink

FREQUENCY (MHz)	GAIN (dB)	DIRECTIVITY (dB)	VSWR (:1)		NOISE FIGURE (dB)	POUT at 3 dB COMPR. (dBm)	POUT at SAT (dBm)	OUTPUT IP3 (dBm)
	28V	28V	IN	OUT	28V	28V	28V	28V
20	52.72	23.56	1.10	5.18	10.77	42.22	43.78	48.43
100	53.49	44.24	1.14	4.17	10.32	41.84	43.79	48.05
200	54.40	42.84	1.14	5.21	10.08	42.04	44.61	48.84
400	53.36	51.13	1.05	4.72	10.05	41.61	44.91	48.49
600	51.51	51.54	1.02	4.23	10.13	41.50	44.58	48.41
800	52.78	41.59	1.01	3.67	10.21	42.74	45.28	50.12
1000	54.02	39.25	1.03	1.77	10.20	44.11	46.44	51.41
1200	51.86	37.33	1.05	1.15	10.19	43.90	45.13	52.40
1400	51.68	47.11	1.04	1.18	10.18	44.73	46.67	53.08
1600	54.45	49.28	1.22	1.63	10.20	44.36	46.83	51.56
1800	53.44	38.84	1.30	2.25	10.21	43.63	45.85	50.37
2000	52.20	46.50	1.19	3.10	10.23	42.77	44.47	49.86

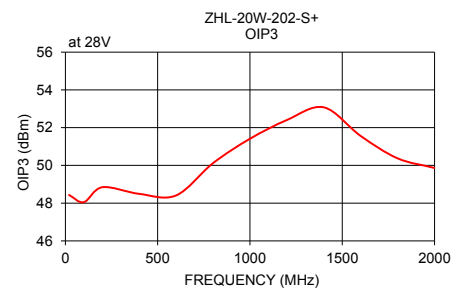
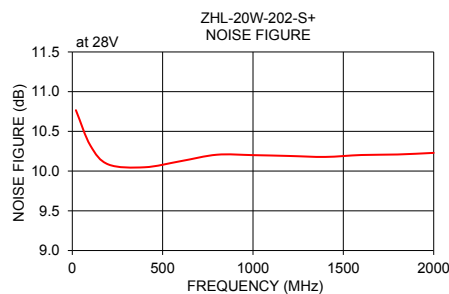
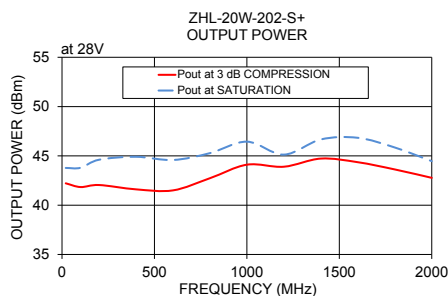
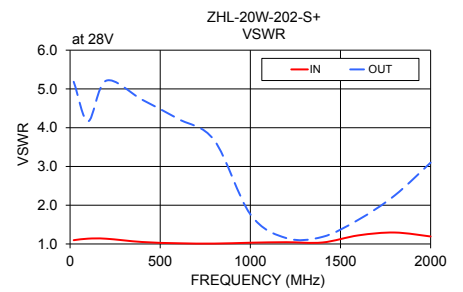
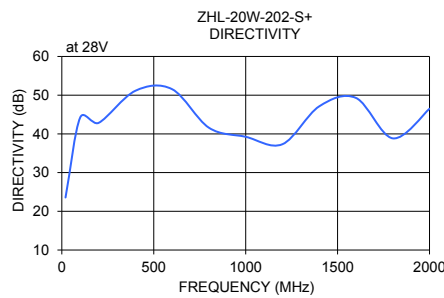
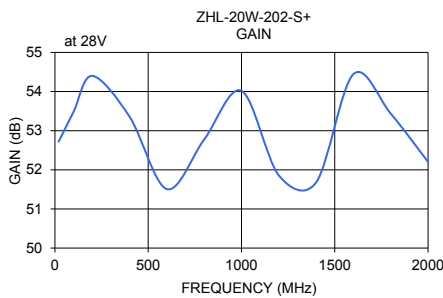

Additional Notes

- Performance and quality attributes and conditions not expressly stated in this specification document are intended to be excluded and do not form a part of this specification document.
- Electrical specifications and performance data contained in this specification document are based on Mini-Circuit's applicable established test performance criteria and measurement instructions.
- The parts covered by this specification document are subject to Mini-Circuits standard limited warranty and terms and conditions (collectively, "Standard Terms"); Purchasers of this part are entitled to the rights and benefits contained therein. For a full statement of the Standard Terms and the exclusive rights and remedies thereunder, please visit Mini-Circuits' website at www.minicircuits.com/MCLStore/terms.jsp