

Surface Mount Power Splitter/Combiner

SCPQ-50+

2 Way-90° 50Ω 25 to 50 MHz



CASE STYLE: YY101

Maximum Ratings

Operating Temperature	-40°C to 85°C
Storage Temperature	-55°C to 100°C
Power Input (as a splitter)	1W max.

Permanent damage may occur if any of these limits are exceeded.

Pin Connections

SUM PORT	1
PORT 1 (+90°)	2
PORT 2 (0°)	5
GROUND	3,4,7,8
CASE GROUND	3,4,7,8
50 OHM TERM EXTERNAL	6

Outline Drawing

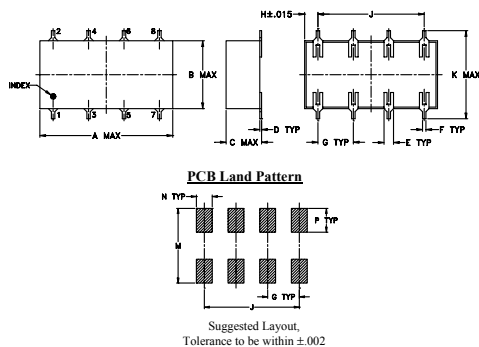

Outline Dimensions (inch/mm)

A	B	C	D	E	F	G	
.75	.38	.20	.010	.050	.020	.200	
19.05	9.65	5.08	0.25	1.27	0.51	5.08	
H	J	K	M	N	P	wt	
.075	.600	.450	.470	.100	.150	grams	
1.91	15.24	11.43	11.94	2.54	3.81	1.6	

Demo Board MCL P/N: TB-51 Suggested PCB Layout (PL-062)

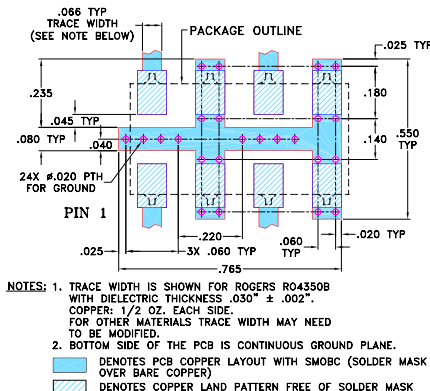

Notes

- Performance and quality attributes and conditions not expressly stated in this specification document are intended to be excluded and do not form a part of this specification document.
- Electrical specifications and performance data contained in this specification document are based on Mini-Circuit's applicable established test performance criteria and measurement instructions.
- The parts covered by this specification document are subject to Mini-Circuit's standard limited warranty and terms and conditions (collectively, "Standard Terms"); Purchasers of this part are entitled to the rights and benefits contained therein. For a full statement of the Standard Terms and the exclusive rights and remedies thereunder, please visit Mini-Circuit's website at www.minicircuits.com/MCLStore/terms.jsp

Features

- low insertion loss, 0.15 dB typ.
- high isolation, 25 dB typ.
- excellent phase unbalance 1 deg. typ.
- excellent VSWR 1.15:1 typ.

Applications

- VHF
- instrumentation
- signal processing
- image reject mixers

Electrical Specifications

FREQ. RANGE (MHz)	ISOLATION (dB)	INSERTION LOSS (dB) Avg. of Coupled Outputs ABOVE 3 dB	PHASE UNBALANCE (Degrees)	AMPLITUDE UNBALANCE (dB)
f_L - f_U	Typ. Min.	Typ. Max.	Max.	Max.
25-50	25 20	0.15 0.7	3	1.5

Typical Performance Data

Frequency (MHz)	Total Loss ¹ (dB)		Amplitude Unbalance (dB)	Isolation (dB)	Phase Unbalance (deg.)	VSWR S	VSWR 1	VSWR 2
	S-1	S-2						
25.00	3.54	2.73	0.82	27.99	89.43	1.12	1.13	1.13
26.25	3.39	2.87	0.52	27.90	89.41	1.13	1.13	1.13
27.50	3.26	3.00	0.26	27.82	89.39	1.13	1.12	1.13
29.38	3.09	3.18	0.09	27.68	89.43	1.13	1.12	1.13
31.25	2.96	3.33	0.37	27.57	89.44	1.13	1.12	1.13
33.13	2.85	3.46	0.61	27.46	89.44	1.13	1.12	1.13
35.00	2.77	3.57	0.80	27.34	89.45	1.13	1.12	1.13
36.88	2.72	3.65	0.93	27.24	89.49	1.13	1.12	1.13
38.75	2.70	3.71	1.02	27.12	89.51	1.13	1.13	1.13
40.63	2.69	3.74	1.05	27.01	89.57	1.14	1.13	1.13
42.50	2.71	3.75	1.03	26.90	89.63	1.14	1.13	1.13
45.00	2.79	3.70	0.92	26.78	89.70	1.15	1.14	1.14
47.50	2.91	3.60	0.70	26.66	89.80	1.15	1.15	1.14
48.75	2.99	3.53	0.54	26.62	89.87	1.16	1.15	1.14
50.00	3.10	3.45	0.35	26.62	89.92	1.16	1.16	1.15

1. Total Loss = Insertion Loss + 3dB splitter loss.

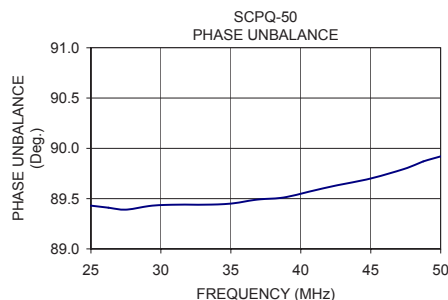
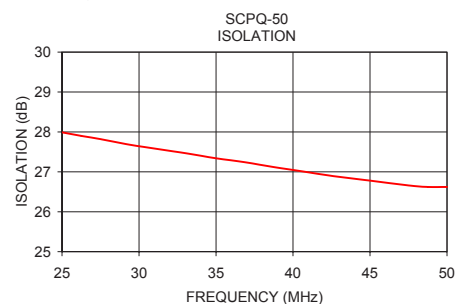
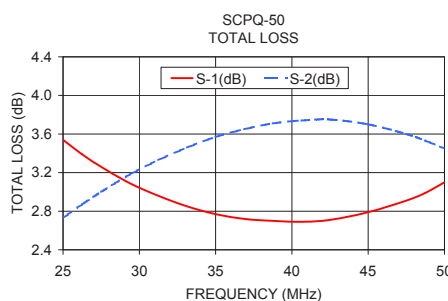

electrical schematic

