

DUAL SUPPLY, LOW ON-STATE RESISTANCE SPST CMOS ANALOG SWITCHES

FEATURES

- ± 1 -V to ± 6 -V Dual-Supply Operation
- Specified ON-State Resistance:
 - 25 Ω Max With ± 5 -V Supply
 - 35 Ω Max With ± 3.3 -V Supply
 - 47 Ω Max With ± 1.8 -V Supply
- Specified Low OFF-Leakage Currents:
 - 5 nA at 25°C
 - 10 nA at 85°C
- Specified Low ON-Leakage Currents:
 - 5 nA at 25°C
 - 10 nA at 85°C
- Low Charge Injection: 13 pC (± 5 -V Supply)
- Fast Switching Speed:
 - $t_{ON} = 85$ ns, $t_{OFF} = 50$ ns (± 5 -V Supply)
- Break-Before-Make Operation ($t_{ON} > t_{OFF}$)
- Latch-Up Performance Exceeds 100 mA Per JESD 78, Class II
- ESD Performance Tested Per JESD 22
 - 2500-V Human-Body Model (A114-F)
 - 1000-V Charged-Device Model (C101-C)
 - 250-V Machine Model (A115-A)

DESCRIPTION/ORDERING INFORMATION

The TS12A4516/TS12A4517 are single pole/single throw (SPST), low-voltage, dual-supply CMOS analog switches, with very low switch ON-state resistance. The TS12A4516 is normally open (NO). The TS12A4517 is normally closed (NC).

These CMOS switches can operate continuously with a dual supplies between ± 1 V and ± 6 V [2 V $< (V_+ - V_-) < 12$ V]. Each switch can handle rail-to-rail analog signals. The OFF-leakage current maximum is only 5 nA at 25°C or 10 nA at 85°C.

For pin-compatible parts for use with single supply, see the TS12A4514/TS12A4515.

ORDERING INFORMATION

T_A	PACKAGE ⁽¹⁾⁽²⁾		ORDERABLE PART NUMBER	TOP-SIDE MARKING
–40°C to 85°C	SOIC – D	Reel of 1500	TS12A4516D	YD516
		Reel of 2500	TS12A4516DR	
	SOP (SOT-23) – DBV	Reel of 3000	TS12A4516DBVR	9CL_
	SOIC – D	Reel of 1500	TS12A4517D	YD517
		Reel of 2500	TS12A4517DR	
	SOP (SOT-23) – DBV	Reel of 3000	TS12A4517DBVR	9CM_

(1) Package drawings, standard packing quantities, thermal data, symbolization, and PCB design guidelines are available at www.ti.com/sc/package.

(2) For the most current package and ordering information, see the Package Option Addendum at the end of this document, or see the TI website at www.ti.com.



Please be aware that an important notice concerning availability, standard warranty, and use in critical applications of Texas Instruments semiconductor products and disclaimers thereto appears at the end of this data sheet.

PIN CONFIGURATIONS

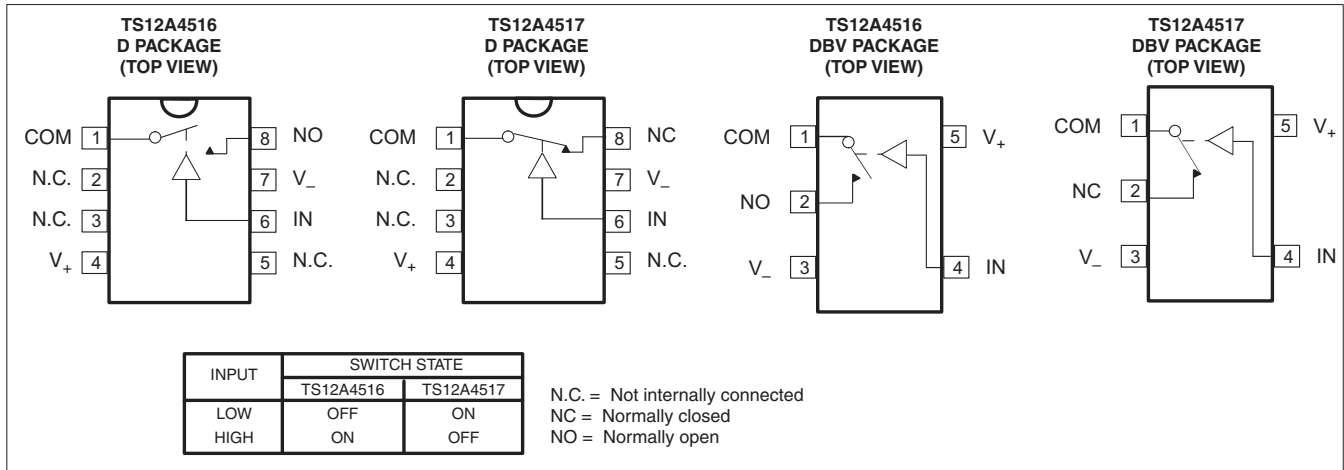

Absolute Minimum and Maximum Ratings⁽¹⁾⁽²⁾

voltages referenced to 0 V

		MIN	MAX	UNIT
V_+	Supply voltage range	-0.3	13	V
V_{NC} V_{NO} V_{COM}	Analog voltage range ⁽³⁾	$V_- - 0.3$	$V_+ + 0.3$	V
V_{IN}	Logic input range	$V_- - 0.3$	$V_+ + 0.3$	V
	Continuous current into any terminal		±20	mA
	Peak current, NO or COM (pulsed at 1 ms, 10% duty cycle)		±30	mA
	ESD per method 3015.7		>2000	V
	Continuous power dissipation ($T_A = 70^\circ\text{C}$)	8-pin SOIC (derate 5.88 mW/°C above 70°C)	471	mW
		5-pin SOT23-5 (derate 7.1 mW/°C above 70°C)	571	
T_A	Operating temperature range	-40	85	°C
T_{stg}	Storage temperature range	-65	150	°C
	Lead temperature (soldering, 10 s)		300	°C

- (1) Stresses beyond those listed under "absolute maximum ratings" may cause permanent damage to the device. These are stress ratings only, and functional operation of the device at these or any other conditions beyond those indicated under "recommended operating conditions" is not implied. Exposure to absolute-maximum-rated conditions for extended periods may affect device reliability.
- (2) The algebraic convention, whereby the most negative value is a minimum and the most positive value is a maximum
- (3) Voltages exceeding V_+ or GND on any signal terminal are clamped by internal diodes. Limit forward-diode current to maximum current rating.

Electrical Characteristics for ±5-V Supply⁽¹⁾
 $V_+ = 4.5\text{ V to }5.5\text{ V}$, $V_- = -4.5\text{ V to }-5.5\text{ V}$, $T_A = -40^\circ\text{C to }85^\circ\text{C}$ (unless otherwise noted)

PARAMETER	SYMBOL	TEST CONDITIONS	T_A	MIN	TYP ⁽²⁾	MAX	UNIT
Analog Switch							
Analog signal range	V_{COM}, V_{NO}, V_{NC}			V_-		V_+	V
ON-state resistance	r_{on}	$V_+ = 4.5\text{ V}, V_- = -4.5\text{ V},$ $V_{COM} = 3.5\text{ V},$ $I_{COM} = 20\text{ mA}$	25°C		12	20	Ω
			Full			25	
ON-state resistance flatness	$r_{on(Flat)}$	$V_+ = 4.5\text{ V}, V_- = -4.5\text{ V},$ $V_{COM} = -3.5\text{ V}, 0\text{ V}, 3.5\text{ V},$ $I_{COM} = 20\text{ mA}$	25°C		1.2	2.5	Ω
			Full			3	
NO, NC OFF leakage current ⁽³⁾	$I_{NO(OFF)},$ $I_{NC(OFF)}$	$V_+ = 5.5\text{ V}, V_- = -5.5\text{ V},$ $V_{COM} = 4.5\text{ V},$ $V_{NO}\text{ or }V_{NC} = -4.5\text{ V}$	25°C			5	nA
			Full			10	
COM OFF leakage current ⁽³⁾	$I_{COM(OFF)}$	$V_+ = 5.5\text{ V}, V_- = -5.5\text{ V},$ $V_{COM} = -4.5\text{ V},$ $V_{NO}\text{ or }V_{NC} = 4.5\text{ V}$	25°C			5	nA
			Full			10	
COM ON leakage current ⁽³⁾	$I_{COM(ON)}$	$V_+ = 5.5\text{ V}, V_- = -5.5\text{ V},$ $V_{COM} = 5.5\text{ V},$ $V_{NO}\text{ or }V_{NC} = \text{open}$	25°C			5	nA
			Full			10	
Digital Control Input (IN)							
Input logic high	V_{IH}		Full	$V_+ - 1.5$			V
Input logic low	V_{IL}		Full	V_-		$V_+ - 3.5$	V
Input leakage current	I_{IH}, I_{IL}	$V_{IN} = V_+, 0\text{ V}$	Full			0.010	μA
Dynamic							
Turn-on time	t_{ON}	See Figure 2	25°C		58	75	ns
			Full			85	
Turn-off time	t_{OFF}	See Figure 2	25°C		28	45	ns
			Full			50	
Charge injection ⁽⁴⁾	Q_C	$C_L = 1\text{ nF}, V_{NO} = 0\text{ V},$ $R_S = 0\text{ }\Omega$, See Figure 1	25°C		-13		pC
NO, NC OFF capacitance	$C_{NO(OFF)},$ $C_{NC(OFF)}$	$f = 1\text{ MHz}$, See Figure 4	25°C		5.5		pF
COM OFF capacitance	$C_{COM(OFF)}$	$f = 1\text{ MHz}$, See Figure 4	25°C		5.5		pF
COM ON capacitance	$C_{COM(ON)}$	$f = 1\text{ MHz}$, See Figure 4	25°C		16		pF
Digital input capacitance	C_I	$V_{IN} = V_+, 0\text{ V}$	25°C		1.5		pF
Bandwidth	BW	$R_L = 50\text{ }\Omega, C_L = 15\text{ pF},$ $V_{NO} = 1\text{ V}_{RMS}, f = 100\text{ kHz}$	25°C		464		MHz
OFF isolation	O_{ISO}	$R_L = 50\text{ }\Omega, C_L = 15\text{ pF},$ $V_{NO} = 1\text{ V}_{RMS}, f = 1\text{ MHz}$	25°C		-83		dB
Total harmonic distortion	THD	$R_L = 600\text{ }\Omega, C_L = 15\text{ pF},$ $V_{NO} = 1\text{ V}_{RMS}, f = 20\text{ kHz}$	25°C		0.07		%
Supply							
V_+ supply current	I_+	$V_{IN} = 0\text{ V or }V_+$	25°C			70	μA
			Full			80	
V_- supply current	I_-	$V_{IN} = 0\text{ V or }V_+$	25°C		-70		μA
			Full		-80		

- (1) The algebraic convention, whereby the most negative value is a minimum and the most positive value is a maximum.
 (2) Typical values are at $T_A = 25^\circ\text{C}$.
 (3) Leakage parameters are 100% tested at maximum-rated hot operating temperature, and are ensured by correlation at 25°C .
 (4) Specified by design, not production tested

Electrical Characteristics for ±3.3-V Supply⁽¹⁾
 $V_+ = 3.0\text{ V to }3.6\text{ V}$, $V_- = -3.0\text{ V to }-3.6$, $T_A = -40^\circ\text{C to }85^\circ\text{C}$ (unless otherwise noted)

PARAMETER	SYMBOL	TEST CONDITIONS	T_A	MIN	TYP ⁽²⁾	MAX	UNIT
Analog Switch							
Analog signal range	$V_{\text{COM}}, V_{\text{NO}}, V_{\text{NC}}$			V_-		V_+	V
ON-state resistance	r_{on}	$V_+ = 3.0\text{ V}, V_- = -3.0\text{ V},$ $V_{\text{COM}} = 3\text{ V},$ $I_{\text{COM}} = 20\text{ mA}$	25°C		17	25	Ω
			Full			35	
ON-state resistance flatness	$r_{\text{on(flat)}}$	$V_{\text{COM}} = -2\text{ V}, 0\text{ V}, 2\text{ V},$ $I_{\text{COM}} = 20\text{ mA}$	25°C		1.5	3	Ω
			Full			4	
NO, NC OFF leakage current ⁽³⁾	$I_{\text{NO(OFF)}},$ $I_{\text{NC(OFF)}}$	$V_+ = 3.6\text{ V}, V_- = -3.6\text{ V},$ $V_{\text{COM}} = 3\text{ V},$ $V_{\text{NO}} \text{ or } V_{\text{NC}} = -3\text{ V}$	25°C			5	nA
			Full			10	
COM OFF leakage current ⁽³⁾	$I_{\text{COM(OFF)}}$	$V_+ = 3.6\text{ V}, V_- = -3.6\text{ V},$ $V_{\text{COM}} = -3\text{ V},$ $V_{\text{NO}} \text{ or } V_{\text{NC}} = 3\text{ V}$	25°C			5	nA
			Full			10	
COM ON leakage current ⁽³⁾	$I_{\text{COM(ON)}}$	$V_+ = 3.6\text{ V}, V_- = -3.6\text{ V},$ $V_{\text{COM}} = 3.6\text{ V},$ $V_{\text{NO}} \text{ or } V_{\text{NC}} = \text{open}$	25°C			5	nA
			Full			10	
Digital Control Input (IN)							
Input logic high	V_{IH}		Full	$V_+ - 1.5$			V
Input logic low	V_{IL}		Full	V_-		$V_+ - 3.5$	V
Input leakage current	$I_{\text{IH}}, I_{\text{IL}}$	$V_{\text{IN}} = V_+, 0\text{ V}$	Full			0.01	μA
Dynamic							
Turn-on time	t_{ON}	see Figure 2	25°C		65	85	ns
			Full			95	
Turn-off time	t_{OFF}	see Figure 2	25°C		37	60	ns
			Full			70	
Charge injection ⁽⁴⁾	Q_{C}	$C_{\text{L}} = 1\text{ nF}, V_{\text{NO}} = 0\text{ V},$ $R_{\text{S}} = 0\text{ }\Omega$, See Figure 1	25°C		-7.5		pC
NO, NC OFF capacitance	$C_{\text{NO(OFF)}},$ $C_{\text{NC(OFF)}}$	$f = 1\text{ MHz}$, See Figure 4	25°C		5.5		pF
COM OFF capacitance	$C_{\text{COM(OFF)}}$	$f = 1\text{ MHz}$, See Figure 4	25°C		5.5		pF
COM ON capacitance	$C_{\text{COM(ON)}}$	$f = 1\text{ MHz}$, See Figure 4	25°C		16		pF
Digital input capacitance	C_{I}	$V_{\text{IN}} = V_+, 0\text{ V}$	25°C		1.5		pF
Bandwidth	BW	$R_{\text{L}} = 50\text{ }\Omega, C_{\text{L}} = 15\text{ pF},$ $V_{\text{NO}} = 1\text{ }V_{\text{RMS}}, f = 100\text{ kHz}$	25°C		464		MHz
OFF isolation	O_{ISO}	$R_{\text{L}} = 50\text{ }\Omega, C_{\text{L}} = 15\text{ pF},$ $V_{\text{NO}} = 1\text{ }V_{\text{RMS}}, f = 100\text{ kHz}$	25°C		-83		dB
Total harmonic distortion	THD	$R_{\text{L}} = 600\text{ }\Omega, C_{\text{L}} = 15\text{ pF},$ $V_{\text{NO}} = 1\text{ }V_{\text{RMS}}, f = 20\text{ kHz}$	25°C		0.10		%
Supply							
V_+ supply current	I_+	$V_{\text{IN}} = 0\text{ V or }V_+$	25°C			40	μA
			Full			45	
V_- supply current	I_-	$V_{\text{IN}} = 0\text{ V or }V_+$	25°C		-40		μA
			Full		45		

(1) The algebraic convention, whereby the most negative value is a minimum and the most positive value is a maximum.

(2) Typical values are at $T_A = 25^\circ\text{C}$.(3) Leakage parameters are 100% tested at maximum-rated hot operating temperature, and are ensured by correlation at 25°C .

(4) Specified by design, not production tested

Electrical Characteristics for ±1.8-V Supply⁽¹⁾
 $V_+ = 1.65\text{ V to }1.95\text{ V}$, $V_- = -1.65\text{ V to }-1.95\text{ V}$, $T_A = -40^\circ\text{C to }85^\circ\text{C}$ (unless otherwise noted)

PARAMETER	SYMBOL	TEST CONDITIONS	T_A	MIN	TYP ⁽²⁾	MAX	UNIT
Analog Switch							
Analog signal range	$V_{\text{COM}}, V_{\text{NO}}, V_{\text{NC}}$			V_-		V_+	V
ON-state resistance	r_{on}	$V_+ = 1.65\text{ V}, V_- = -1.65\text{ V},$ $V_{\text{COM}} = 0\text{ V},$ $I_{\text{COM}} = 20\text{ mA}$	25°C		28	40	Ω
			Full			47	
ON-state resistance flatness	$r_{\text{on(Flat)}}$	$V_+ = 1.65\text{ V}, V_- = -1.65\text{ V},$ $V_{\text{COM}} = -1.8\text{ V}, 0\text{ V}, 1.5\text{ V},$ $I_{\text{COM}} = 20\text{ mA}$	25°C		9	13	Ω
			Full			15	
NO, NC OFF leakage current ⁽³⁾	$I_{\text{NO(OFF)}},$ $I_{\text{NC(OFF)}}$	$V_+ = 1.95\text{ V}, V_- = -1.95\text{ V},$ $V_{\text{COM}} = 1.65\text{ V},$ $V_{\text{NO}} \text{ or } V_{\text{NC}} = -1.65\text{ V}$	25°C			5	nA
			Full			10	
COM OFF leakage current ⁽³⁾	$I_{\text{COM(OFF)}}$	$V_+ = 1.95\text{ V}, V_- = -1.95\text{ V},$ $V_{\text{COM}} = -1.65\text{ V},$ $V_{\text{NO}} \text{ or } V_{\text{NC}} = 1.65\text{ V}$	25°C			5	nA
			Full			10	
COM ON leakage current ⁽³⁾	$I_{\text{COM(ON)}}$	$V_+ = 1.95\text{ V}, V_- = -1.95\text{ V},$ $V_{\text{COM}} = 1.95\text{ V},$ $V_{\text{NO}} \text{ or } V_{\text{NC}} = \text{open}$	25°C			5	nA
			Full			10	
Digital Control Input (IN)							
Input logic high	V_{IH}		Full	$V_+ - 1.5$			V
Input logic low	V_{IL}		Full	V_-		$V_+ - 3.5$	V
Input leakage current	$I_{\text{IH}}, I_{\text{IL}}$	$V_{\text{IN}} = V_+, 0\text{ V}$	Full			0.01	μA
Dynamic							
Turn-on time ⁽⁴⁾	t_{ON}	See Figure 2	25°C		90	120	ns
			Full			150	
Turn-off time ⁽⁴⁾	t_{OFF}	See Figure 2	25°C		95	150	ns
			Full			200	
Charge injection ⁽⁴⁾	Q_{C}	$C_{\text{L}} = 1\text{ nF}$, See Figure 1	25°C		-3.5		pC
NO, NC OFF capacitance	$C_{\text{NO(OFF)}},$ $C_{\text{NC(OFF)}}$	$f = 1\text{ MHz}$, See Figure 4	25°C		6		pF
COM OFF capacitance	$C_{\text{COM(OFF)}}$	$f = 1\text{ MHz}$, See Figure 4	25°C		6		pF
COM ON capacitance	$C_{\text{COM(ON)}}$	$f = 1\text{ MHz}$, See Figure 4	25°C		14.5		pF
Digital input capacitance	C_{I}	$V_{\text{IN}} = V_+, 0\text{ V}$	25°C		1.5		pF
Bandwidth	BW	$R_{\text{L}} = 50\ \Omega, C_{\text{L}} = 15\text{ pF},$ $V_{\text{NO}} = 1\text{ V}_{\text{RMS}}, f = 100\text{ kHz}$	25°C		464		MHz
OFF isolation	O_{ISO}	$R_{\text{L}} = 50\ \Omega, C_{\text{L}} = 15\text{ pF},$ $V_{\text{NO}} = 1\text{ V}_{\text{RMS}}, f = 1\text{ MHz}$	25°C		-83		dB
Total harmonic distortion	THD	$R_{\text{L}} = 600\ \Omega, C_{\text{L}} = 50\text{ pF},$ $V_{\text{NO}} = 1\text{ V}_{\text{RMS}}, f = 20\text{ kHz}$	25°C		0.37		%
Supply							
V_+ supply current	I_+	$V_{\text{IN}} = 0\text{ V or } V_+$	25°C			20	μA
			Full			30	
V_- supply current	I_-	$V_{\text{IN}} = 0\text{ V or } V_+$	25°C		-20		μA
			Full		-30		

- (1) The algebraic convention, whereby the most negative value is a minimum and the most positive value is a maximum.
 (2) Typical values are at $T_A = 25^\circ\text{C}$.
 (3) Leakage parameters are 100% tested at maximum-rated hot operating temperature, and are ensured by correlation at 25°C .
 (4) Specified by design, not production tested

PIN DESCRIPTION⁽¹⁾

PIN NO.				NAME	DESCRIPTION
TS12A4516		TS12A4517			
D, P	SOT23-5	D, P	SOT23-5		
1	1	1	1	COM	Common
2, 3, 5	–	2, 3, 5	–	N.C.	No connect (not internally connected)
4	5	4	5	V ₊	Positive power supply
6	4	6	4	IN	Digital control to connect COM to NO or NC
7	3	7	3	V ₋	Negative power supply
8	2	–	–	NO	Normally open
–	–	8	2	NC	Normally closed

(1) NO, NC, and COM pins are identical and interchangeable. Any may be considered as an input or an output; signals pass in both directions.

APPLICATION INFORMATION

Power-Supply Considerations

The TS12A4516 and TS12A4517 operate with power-supply voltages from ± 1 V to ± 6 V [$(2 \text{ V} < (V_+ - V_-) < 12 \text{ V})$], but are tested and specified at ± 5 V, ± 3.3 V, and ± 1.8 V supplies. The pin-compatible TS12A4514 and TS12A4515 are recommended for use when only a single supply is desirable.

The TS12A4516 and TS12A4517 construction is typical of most CMOS analog switches, except that they have only two supply pins: V_+ and V_- . V_+ and V_- drive the internal CMOS switches and set their analog voltage limits. Reverse ESD-protection diodes are internally connected between each analog-signal pin and both V_+ and V_- . One of these diodes conducts if any analog signal exceeds V_+ or V_- .

Virtually all the analog leakage current comes from the ESD diodes to V_+ or V_- . Although the ESD diodes on a given signal pin are identical and, therefore, fairly well balanced, they are reverse biased differently. Each is biased by either V_+ or V_- and the analog signal. This means their leakages will vary as the signal varies. The difference in the two diode leakages to the V_+ and V_- pins constitutes the analog-signal-path leakage current. All analog leakage current flows between each pin and one of the supply terminals, not to the other switch terminal. This is why both sides of a given switch can show leakage currents of the same or opposite polarity.

V_+ and V_- also power the internal logic and logic-level translators. The logic-level translators convert the logic levels to switched V_+ and V_- signals to drive the analog signal gates.

Logic-Level Thresholds

Since these parts have no ground pin, the logic-level threshold is referenced to V_+ . The threshold limits are $V_+ - 1.5$ V and $V_+ - 3.5$ V for V_+ levels between 6 V and 3 V. When $V_+ = 2$ V, the logic threshold is approximately 0.6 V.

CAUTION:

Do not connect the TS12A4516/TS12A4517 V_+ to 3 V and then connect the logic-level pins to logic-level signals that operate from 5-V supply. TTL levels can exceed 3 V and violate the absolute maximum ratings, damaging the part and/or external circuits.

Test Circuits/Timing Diagrams

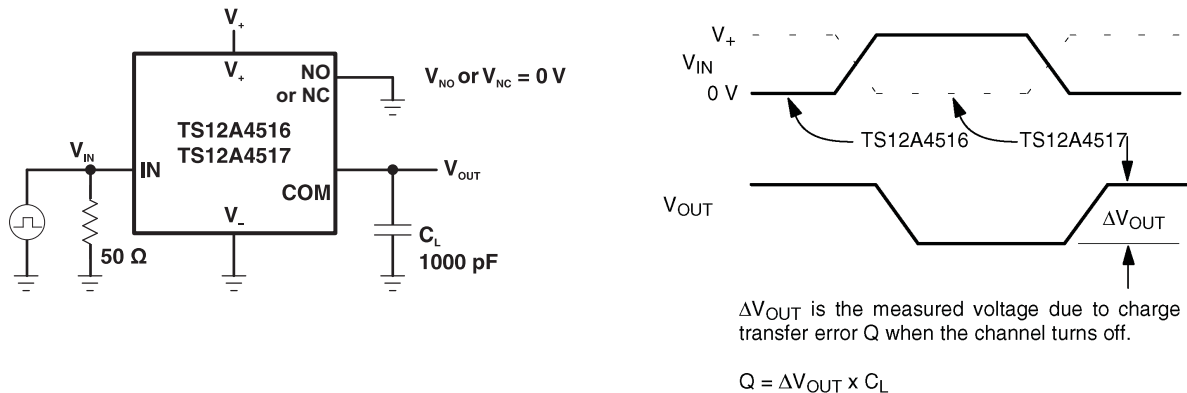

Figure 1. Charge Injection

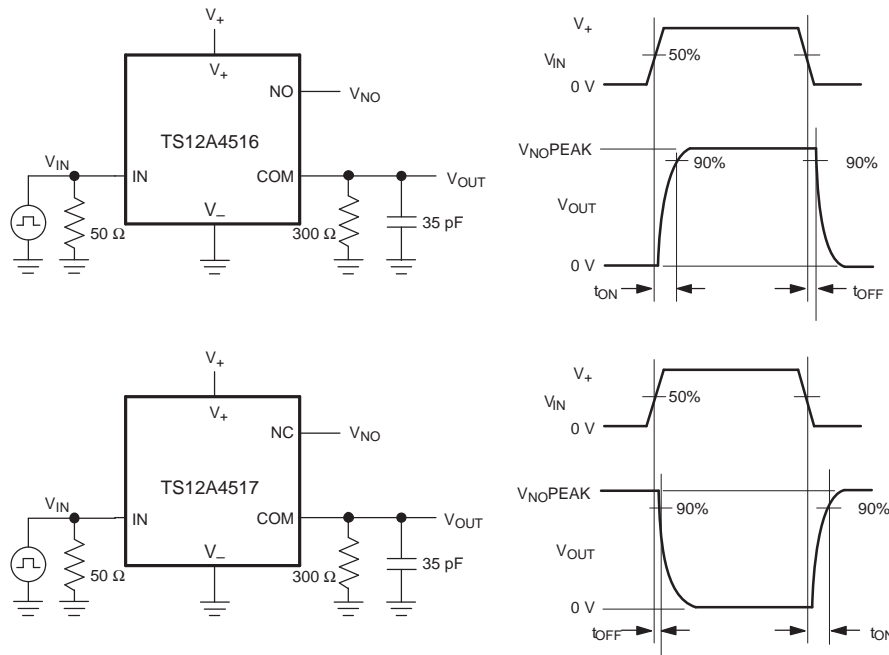
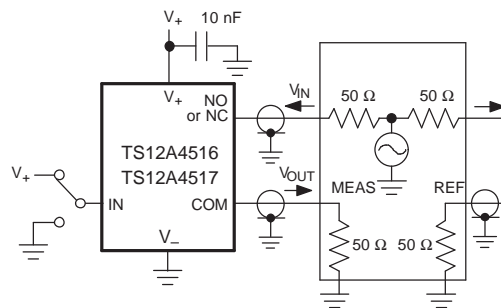

Figure 2. Switching Times



Measurements are standardized against short at socket terminals. OFF isolation is measured between COM and OFF terminals on each switch. ON loss is measured between COM and ON terminals on each switch. Signal direction through switch is reversed; worst values are recorded.

$$\text{OFF Isolation} = 20 \log \frac{V_{OUT}}{V_{IN}}$$

$$\text{ON Loss} = 20 \log \frac{V_{OUT}}{V_{IN}}$$

Figure 3. OFF Isolation and ON Loss

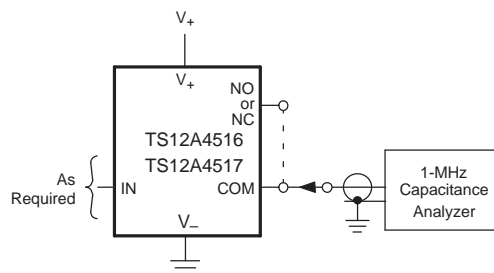

Figure 4. NO, NC, and COM Capacitance

PACKAGING INFORMATION

Orderable Device	Status ⁽¹⁾	Package Type	Package Drawing	Pins	Package Qty	Eco Plan ⁽²⁾	Lead/Ball Finish	MSL Peak Temp ⁽³⁾
TS12A4516D	ACTIVE	SOIC	D	8	75	Green (RoHS & no Sb/Br)	CU NIPDAU	Level-1-260C-UNLIM
TS12A4516DBVR	ACTIVE	SOT-23	DBV	5	3000	Green (RoHS & no Sb/Br)	CU NIPDAU	Level-1-260C-UNLIM
TS12A4516DG4	ACTIVE	SOIC	D	8	75	Green (RoHS & no Sb/Br)	CU NIPDAU	Level-1-260C-UNLIM
TS12A4516DR	ACTIVE	SOIC	D	8	2500	Green (RoHS & no Sb/Br)	CU NIPDAU	Level-1-260C-UNLIM
TS12A4516DRG4	ACTIVE	SOIC	D	8	2500	Green (RoHS & no Sb/Br)	CU NIPDAU	Level-1-260C-UNLIM
TS12A4517D	ACTIVE	SOIC	D	8	75	Green (RoHS & no Sb/Br)	CU NIPDAU	Level-1-260C-UNLIM
TS12A4517DBVR	ACTIVE	SOT-23	DBV	5	3000	Green (RoHS & no Sb/Br)	CU NIPDAU	Level-1-260C-UNLIM
TS12A4517DG4	ACTIVE	SOIC	D	8	75	Green (RoHS & no Sb/Br)	CU NIPDAU	Level-1-260C-UNLIM
TS12A4517DR	ACTIVE	SOIC	D	8	2500	Green (RoHS & no Sb/Br)	CU NIPDAU	Level-1-260C-UNLIM
TS12A4517DRG4	ACTIVE	SOIC	D	8	2500	Green (RoHS & no Sb/Br)	CU NIPDAU	Level-1-260C-UNLIM

⁽¹⁾ The marketing status values are defined as follows:

ACTIVE: Product device recommended for new designs.

LIFEBUY: TI has announced that the device will be discontinued, and a lifetime-buy period is in effect.

NRND: Not recommended for new designs. Device is in production to support existing customers, but TI does not recommend using this part in a new design.

PREVIEW: Device has been announced but is not in production. Samples may or may not be available.

OBsolete: TI has discontinued the production of the device.

⁽²⁾ Eco Plan - The planned eco-friendly classification: Pb-Free (RoHS), Pb-Free (RoHS Exempt), or Green (RoHS & no Sb/Br) - please check <http://www.ti.com/productcontent> for the latest availability information and additional product content details.

TBD: The Pb-Free/Green conversion plan has not been defined.

Pb-Free (RoHS): TI's terms "Lead-Free" or "Pb-Free" mean semiconductor products that are compatible with the current RoHS requirements for all 6 substances, including the requirement that lead not exceed 0.1% by weight in homogeneous materials. Where designed to be soldered at high temperatures, TI Pb-Free products are suitable for use in specified lead-free processes.

Pb-Free (RoHS Exempt): This component has a RoHS exemption for either 1) lead-based flip-chip solder bumps used between the die and package, or 2) lead-based die adhesive used between the die and leadframe. The component is otherwise considered Pb-Free (RoHS compatible) as defined above.

Green (RoHS & no Sb/Br): TI defines "Green" to mean Pb-Free (RoHS compatible), and free of Bromine (Br) and Antimony (Sb) based flame retardants (Br or Sb do not exceed 0.1% by weight in homogeneous material)

⁽³⁾ MSL, Peak Temp. -- The Moisture Sensitivity Level rating according to the JEDEC industry standard classifications, and peak solder temperature.

Important Information and Disclaimer: The information provided on this page represents TI's knowledge and belief as of the date that it is provided. TI bases its knowledge and belief on information provided by third parties, and makes no representation or warranty as to the accuracy of such information. Efforts are underway to better integrate information from third parties. TI has taken and continues to take reasonable steps to provide representative and accurate information but may not have conducted destructive testing or chemical analysis on incoming materials and chemicals. TI and TI suppliers consider certain information to be proprietary, and thus CAS numbers and other limited information may not be available for release.

In no event shall TI's liability arising out of such information exceed the total purchase price of the TI part(s) at issue in this document sold by TI to Customer on an annual basis.

TAPE AND REEL INFORMATION

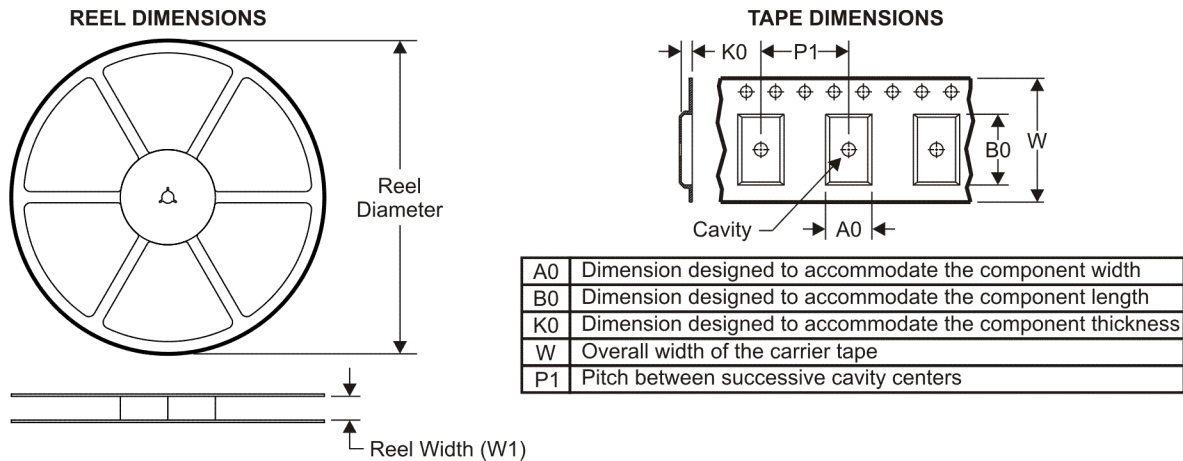

QUADRANT ASSIGNMENTS FOR PIN 1 ORIENTATION IN TAPE

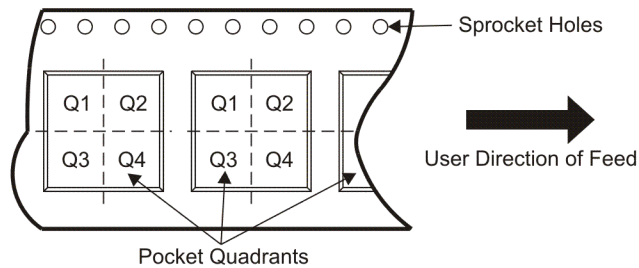

*All dimensions are nominal

Device	Package Type	Package Drawing	Pins	SPQ	Reel Diameter (mm)	Reel Width W1 (mm)	A0 (mm)	B0 (mm)	K0 (mm)	P1 (mm)	W (mm)	Pin1 Quadrant
TS12A4516DBVR	SOT-23	DBV	5	3000	180.0	9.2	3.23	3.17	1.37	4.0	8.0	Q3
TS12A4516DR	SOIC	D	8	2500	330.0	12.4	6.4	5.2	2.1	8.0	12.0	Q1
TS12A4517DR	SOIC	D	8	2500	330.0	12.4	6.4	5.2	2.1	8.0	12.0	Q1

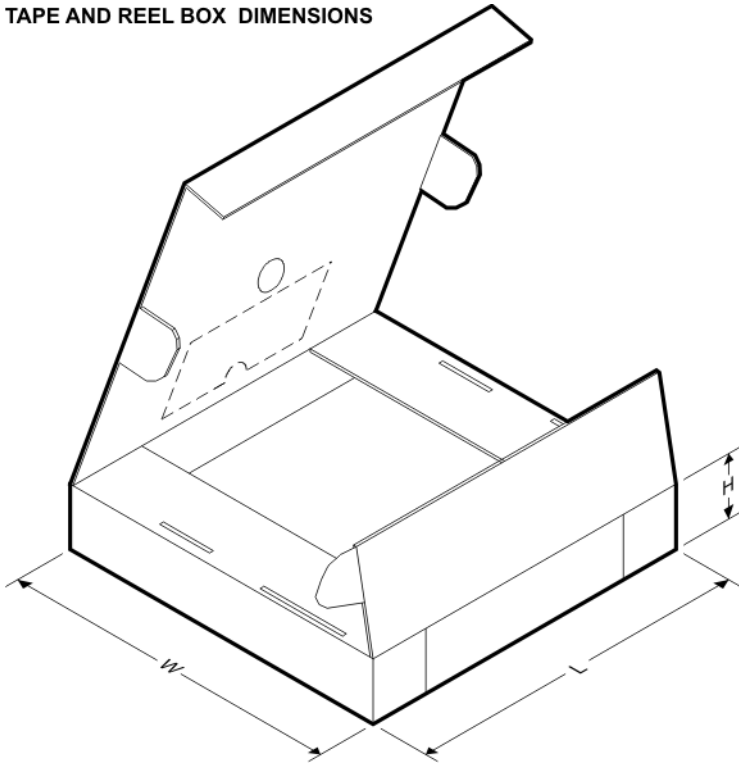
TAPE AND REEL BOX DIMENSIONS

*All dimensions are nominal

Device	Package Type	Package Drawing	Pins	SPQ	Length (mm)	Width (mm)	Height (mm)
TS12A4516DBVR	SOT-23	DBV	5	3000	202.0	201.0	28.0
TS12A4516DR	SOIC	D	8	2500	346.0	346.0	29.0
TS12A4517DR	SOIC	D	8	2500	346.0	346.0	29.0

DBV (R-PDSO-G5)

PLASTIC SMALL-OUTLINE PACKAGE

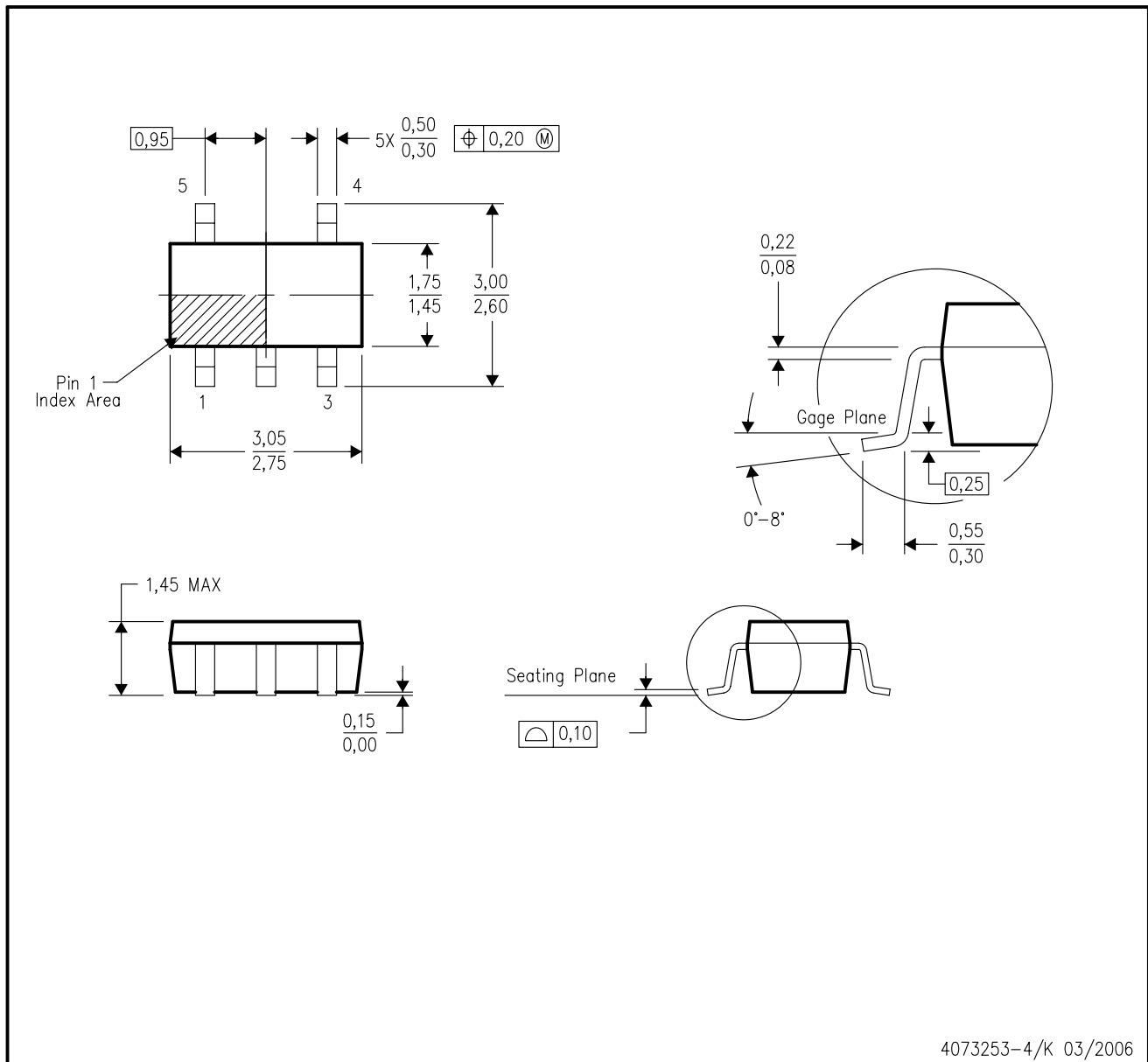

- NOTES:
- A. All linear dimensions are in millimeters.
 - B. This drawing is subject to change without notice.
 - C. Body dimensions do not include mold flash or protrusion. Mold flash and protrusion shall not exceed 0.15 per side.
 - D. Falls within JEDEC MO-178 Variation AA.

D (R-PDSO-G8)

PLASTIC SMALL-OUTLINE PACKAGE

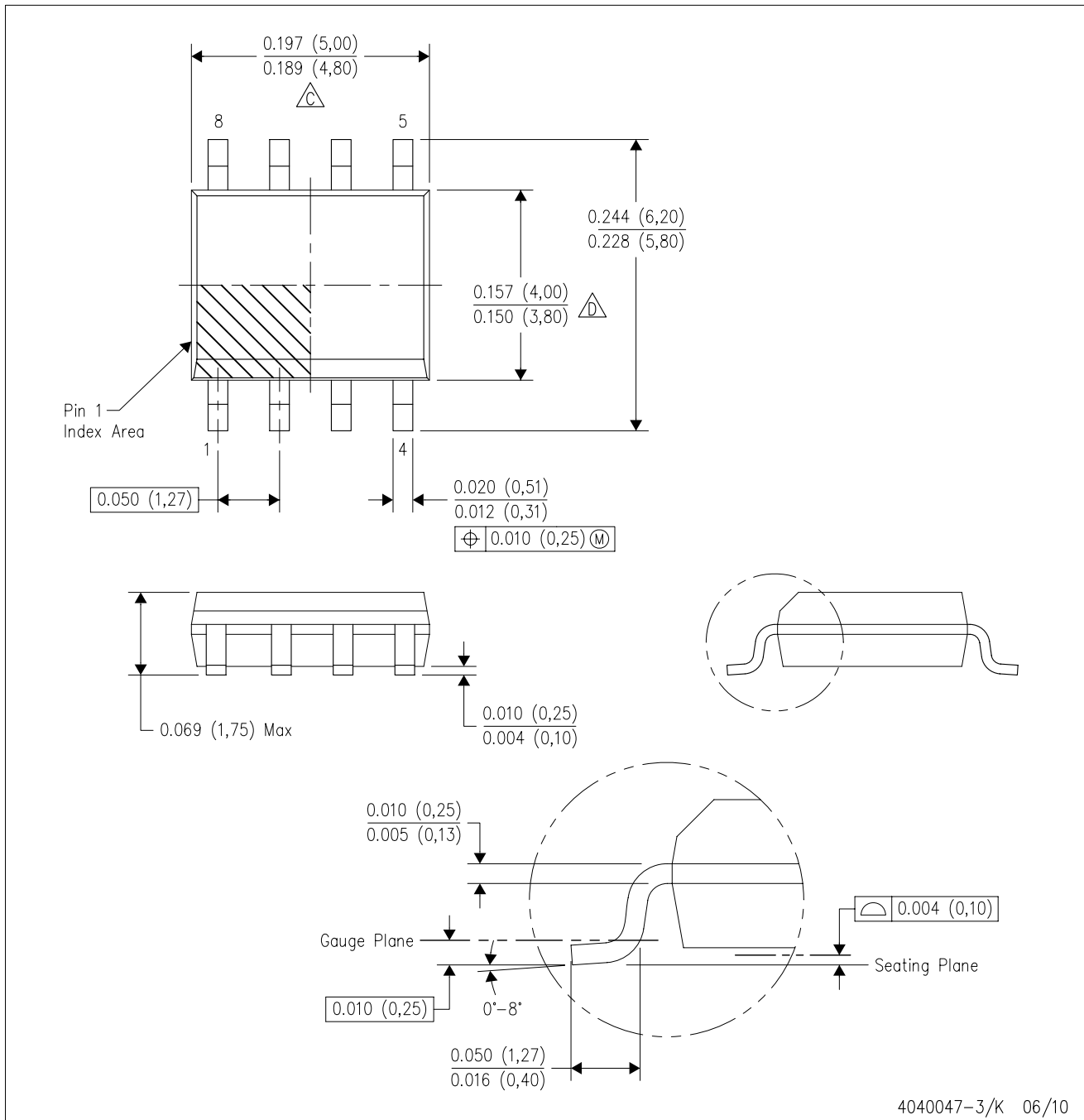

- NOTES:
- A. All linear dimensions are in inches (millimeters).
 - B. This drawing is subject to change without notice.
 - C. Body length does not include mold flash, protrusions, or gate burrs. Mold flash, protrusions, or gate burrs shall not exceed .006 (0,15) per end.
 - D. Body width does not include interlead flash. Interlead flash shall not exceed .017 (0,43) per side.
 - E. Reference JEDEC MS-012 variation AA.

IMPORTANT NOTICE

Texas Instruments Incorporated and its subsidiaries (TI) reserve the right to make corrections, modifications, enhancements, improvements, and other changes to its products and services at any time and to discontinue any product or service without notice. Customers should obtain the latest relevant information before placing orders and should verify that such information is current and complete. All products are sold subject to TI's terms and conditions of sale supplied at the time of order acknowledgment.

TI warrants performance of its hardware products to the specifications applicable at the time of sale in accordance with TI's standard warranty. Testing and other quality control techniques are used to the extent TI deems necessary to support this warranty. Except where mandated by government requirements, testing of all parameters of each product is not necessarily performed.

TI assumes no liability for applications assistance or customer product design. Customers are responsible for their products and applications using TI components. To minimize the risks associated with customer products and applications, customers should provide adequate design and operating safeguards.

TI does not warrant or represent that any license, either express or implied, is granted under any TI patent right, copyright, mask work right, or other TI intellectual property right relating to any combination, machine, or process in which TI products or services are used. Information published by TI regarding third-party products or services does not constitute a license from TI to use such products or services or a warranty or endorsement thereof. Use of such information may require a license from a third party under the patents or other intellectual property of the third party, or a license from TI under the patents or other intellectual property of TI.

Reproduction of TI information in TI data books or data sheets is permissible only if reproduction is without alteration and is accompanied by all associated warranties, conditions, limitations, and notices. Reproduction of this information with alteration is an unfair and deceptive business practice. TI is not responsible or liable for such altered documentation. Information of third parties may be subject to additional restrictions.

Resale of TI products or services with statements different from or beyond the parameters stated by TI for that product or service voids all express and any implied warranties for the associated TI product or service and is an unfair and deceptive business practice. TI is not responsible or liable for any such statements.

TI products are not authorized for use in safety-critical applications (such as life support) where a failure of the TI product would reasonably be expected to cause severe personal injury or death, unless officers of the parties have executed an agreement specifically governing such use. Buyers represent that they have all necessary expertise in the safety and regulatory ramifications of their applications, and acknowledge and agree that they are solely responsible for all legal, regulatory and safety-related requirements concerning their products and any use of TI products in such safety-critical applications, notwithstanding any applications-related information or support that may be provided by TI. Further, Buyers must fully indemnify TI and its representatives against any damages arising out of the use of TI products in such safety-critical applications.

TI products are neither designed nor intended for use in military/aerospace applications or environments unless the TI products are specifically designated by TI as military-grade or "enhanced plastic." Only products designated by TI as military-grade meet military specifications. Buyers acknowledge and agree that any such use of TI products which TI has not designated as military-grade is solely at the Buyer's risk, and that they are solely responsible for compliance with all legal and regulatory requirements in connection with such use.

TI products are neither designed nor intended for use in automotive applications or environments unless the specific TI products are designated by TI as compliant with ISO/TS 16949 requirements. Buyers acknowledge and agree that, if they use any non-designated products in automotive applications, TI will not be responsible for any failure to meet such requirements.

Following are URLs where you can obtain information on other Texas Instruments products and application solutions:

Products		Applications	
Amplifiers	amplifier.ti.com	Audio	www.ti.com/audio
Data Converters	dataconverter.ti.com	Automotive	www.ti.com/automotive
DLP® Products	www.dlp.com	Communications and Telecom	www.ti.com/communications
DSP	dsp.ti.com	Computers and Peripherals	www.ti.com/computers
Clocks and Timers	www.ti.com/clocks	Consumer Electronics	www.ti.com/consumer-apps
Interface	interface.ti.com	Energy	www.ti.com/energy
Logic	logic.ti.com	Industrial	www.ti.com/industrial
Power Mgmt	power.ti.com	Medical	www.ti.com/medical
Microcontrollers	microcontroller.ti.com	Security	www.ti.com/security
RFID	www.ti-rfid.com	Space, Avionics & Defense	www.ti.com/space-avionics-defense
RF/IF and ZigBee® Solutions	www.ti.com/lprf	Video and Imaging	www.ti.com/video
		Wireless	www.ti.com/wireless-apps

Mailing Address: Texas Instruments, Post Office Box 655303, Dallas, Texas 75265
Copyright © 2010, Texas Instruments Incorporated