

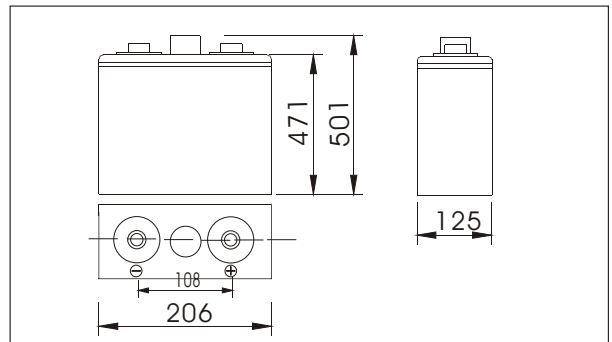

# SW23500(2V350AH)



### Outer dimensions (mm)



### Specifications

Nominal Voltage	2 V	
Rated capacity (10 hour rate)	350 Ah	
Dimensions	Total Height	501 mm (19.72 inches)
	Height	471 mm (18.54 inches)
	Length	206 mm (8.11 inches)
	Width	125 mm (4.92 inches)
Weight Approx	25Kg (55.25lbs)	

### Terminal Type (mm)

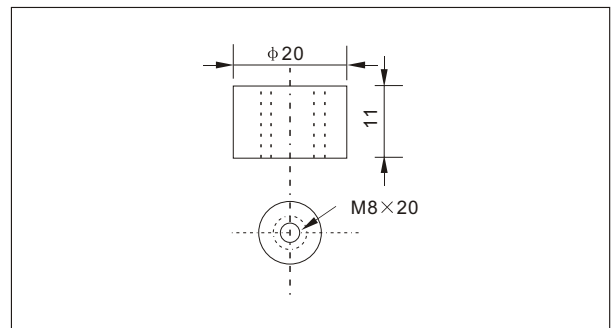

### Characteristics

Capacity 25°C(77°F)	10 hour rate(35A) 5 hour rate(56A) 1 hour rate(210A)	350 AH 280 AH 210 AH
Internal Resistance	Full charged Battery at 25°C(77°F)	Approx 0.43 mΩ
Capacity affected by Temperature (10hour rate)	40°C(104°F) 25°C(77°F) 0°C(32°F) -15°C(5°F)	102% 100% 85% 65%
Self-Discharge at 25°C(77°F)	Capacity after 3 month storage Capacity after 6 month storage Capacity after 12 month storage	91% 82% 64%
Terminal	T37	
Charge (constant Voltage)	Cycle	Initial Charging Current less than 140 A Voltage 2.35-2.40V
	Float	Voltage 2.25-2.30V

### Discharge Curves 25°C(77°F)

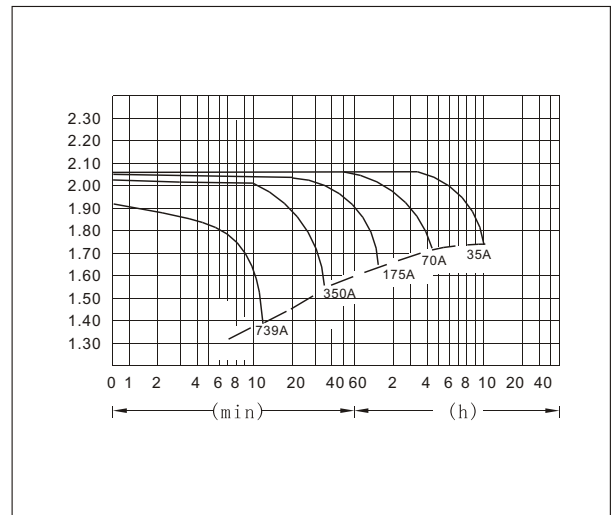

Time	5min	10min	15min	30min	1h	2h	3h	4h	5h	8h	10h	20h
1.60V	A	1121	739	595	399	210	122.5	90.0	70.0	57.8	41.0	20
	W	1928	1315	1064	715	378	224	166.9	131.3	109.4	78.2	38
1.70V	A	1086	666	561	382	197	116.9	87.5	68.3	56.7	39.9	19.3
	W	1933	1240	1046	714	372	225	168.9	132.3	110.2	77.8	37.6
1.75V	A	1050	596	490	357	191	114.1	85.4	67.2	56.0	39.6	19.3
	W	1912	1130	933	685	369	221	165.8	131.0	109.4	77.5	37.9
1.80V	A	1012	562	456	329	185	111.3	83.3	66.2	54.6	38.5	18.9
	W	1893	1080	875	635	359	217	163.7	130.2	107.6	76.0	37.5
1.85V	A	978	526	421	294	179	108.5	80.5	64.4	53.2	37.5	17.9
	W	1849	1016	816	573	350	214	159.4	127.8	105.8	74.8	36.1