

THIS DRAWING IS UNPUBLISHED. RELEASED FOR PUBLICATION 20  
 © COPYRIGHT 20 BY - ALL RIGHTS RESERVED.

LOC	DIST	REVISIONS					
CM	00	P	LTR	DESCRIPTION	DATE	DWN	APVD
		A1		REVISED PER ECR-12-003555	19APR2012	RS	DD
		A2		REVISED PER ECR-12-016877	20OCT2012	RS	DD
		B		REVISED PER ECR-15-004054	28JUL2015	RS	DD
		C		REVISED PER ECR-15-017995	18DEC2015	RS	DD

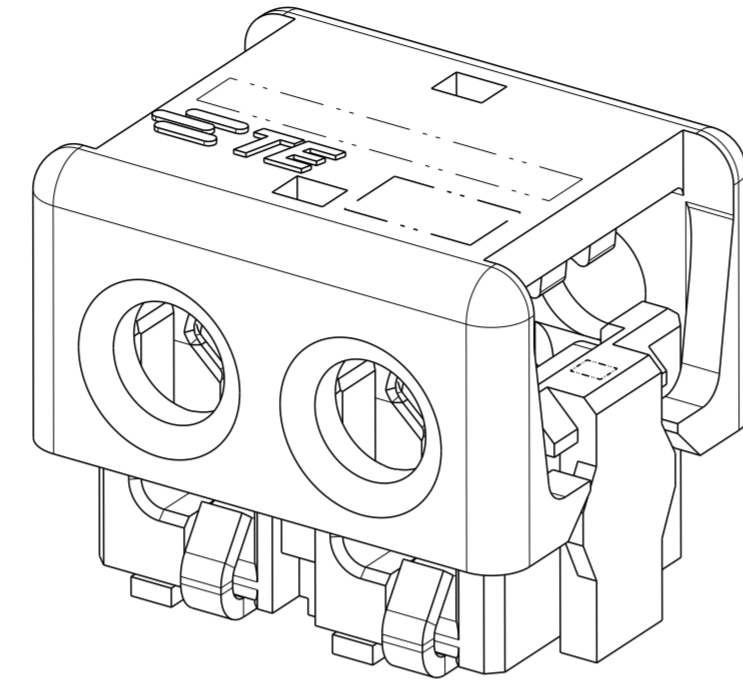
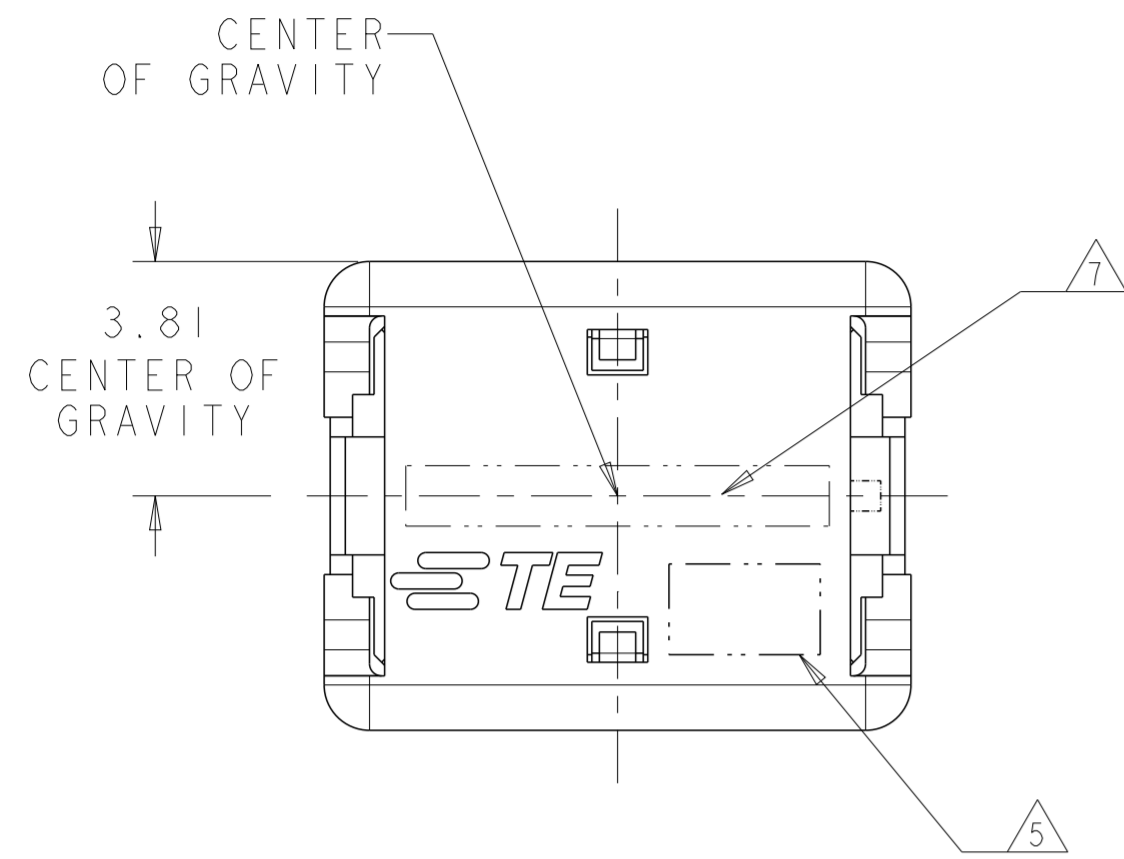

- 1. MATERIALS AND FINISH:
  - HOUSING: LCP, COLOR: NATURAL
  - CONTACTS: COPPER ALLOY, FINISH: Sn OVER Ni

2. COMPLY WITH DIRECTIVE 2002/95/EC (ROHS).

- 3. 18-24AWG SOLID OR STRANDED WIRE. PLEASE REFER TO APPLICATION SPEC 114-13266 FOR RECOMMENDED STRAND COUNT.
  - 18AWG MAX INSULATION OD: 2.20
  - 20AWG MAX INSULATION OD: 1.90
  - 22AWG MAX INSULATION OD: 1.70
  - 24AWG MAX INSULATION OD: 1.45

4. PACKAGE IN TAPE AND REEL PER EIA-481 SPECIFICATION, EXCEPT 1 POSITION CONNECTOR.

- 5. WIRE SIZE MARKING IN APPROXIMATE LOCATION SHOWN.
- 6. DATUMS AND BASIC DIMENSIONS ESTABLISHED BY CUSTOMER.
- 7. COLOR CODE MARKING, STRAIGHT LINE.
- 8. 1 POSITION ASSEMBLY DOES NOT COMPLY WITH EIA 481 SPECIFICATION.

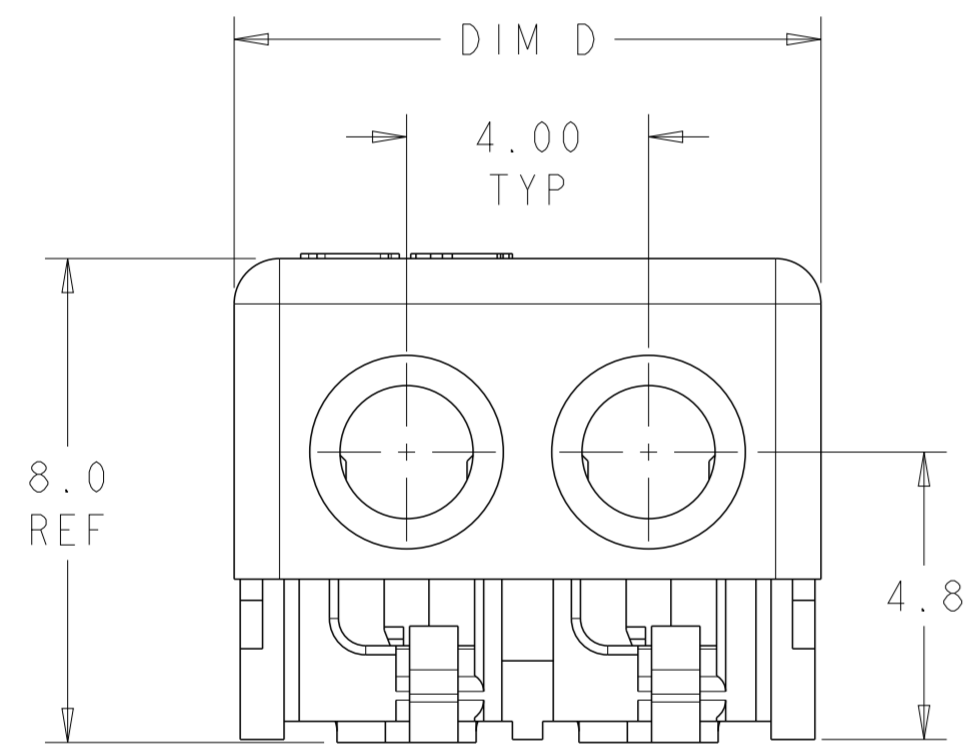

2 POSITION SHOWN AS SHIPPED

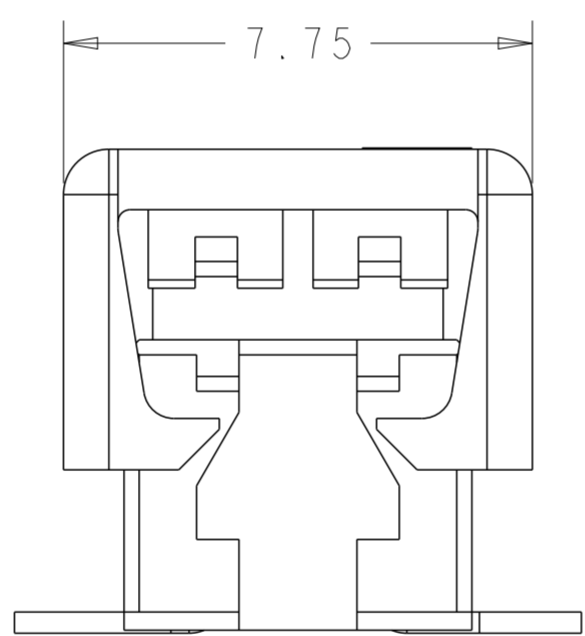

FOR 1 POSITION ONLY

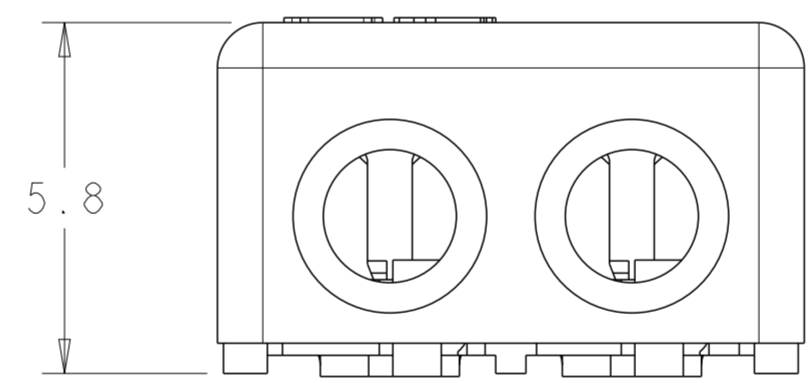

2 POSITION SHOWN CLOSED SCALE 8:1

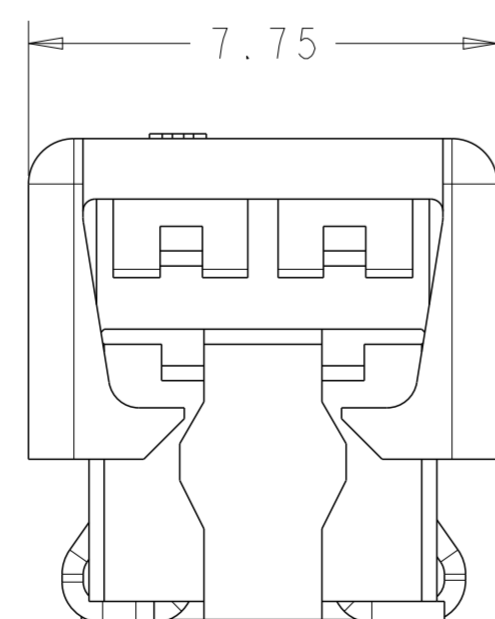

FOR 2, 3 AND 4 POSITIONS

COLOR CODE	DIM D	WIRE SIZE	POSN	PART NUMBER
RED	17.70	24 AWG	4	3-2106431-4
	13.70	24 AWG	3	3-2106431-3
	9.70	24 AWG	2	3-2106431-2
	5.70	24 AWG	1	8 3-2106431-1
GREEN	17.70	22 AWG	4	2-2106431-4
	13.70	22 AWG	3	2-2106431-3
	9.70	22 AWG	2	2-2106431-2
	5.70	22 AWG	1	8 2-2106431-1
BLUE	17.70	20 AWG	4	1-2106431-4
	13.70	20 AWG	3	1-2106431-3
	9.70	20 AWG	2	1-2106431-2
	5.70	20 AWG	1	8 1-2106431-1
YELLOW	17.70	18 AWG	4	2106431-4
	13.70	18 AWG	3	2106431-3
	9.70	18 AWG	2	2106431-2
	5.70	18 AWG	1	8 2106431-1

THIS DRAWING IS A CONTROLLED DOCUMENT. DWN C DAILY 09DEC2008  
 CHK J DYER 09DEC2008

**STE** TE Connectivity

ASSEMBLY, IDC SSL CONNECTOR, SMT, PASS THRU

DIMENSIONS: mm	TOLERANCES UNLESS OTHERWISE SPECIFIED:	PRODUCT SPEC 108-2404	SIZE A2	CAGE CODE 00779	DRAWING NO C-2106431	RESTRICTED TO
0 PLC ±	1 PLC ±0.5	APPLICATION SPEC 114-13266	SCALE 8:1	SHEET 1	OF 3	REV C
2 PLC ±0.13	3 PLC ±	WEIGHT -	Customer Drawing			
4 PLC ±	ANGLES ±					
FINISH						

THIS DRAWING IS UNPUBLISHED. RELEASED FOR PUBLICATION 20  
 © COPYRIGHT 20 BY - ALL RIGHTS RESERVED.

LOC		DIST		REVISIONS				
P	LTR	DESCRIPTION			DATE	DWN	APVD	
-	-	SEE SHEET 1			-	-	-	

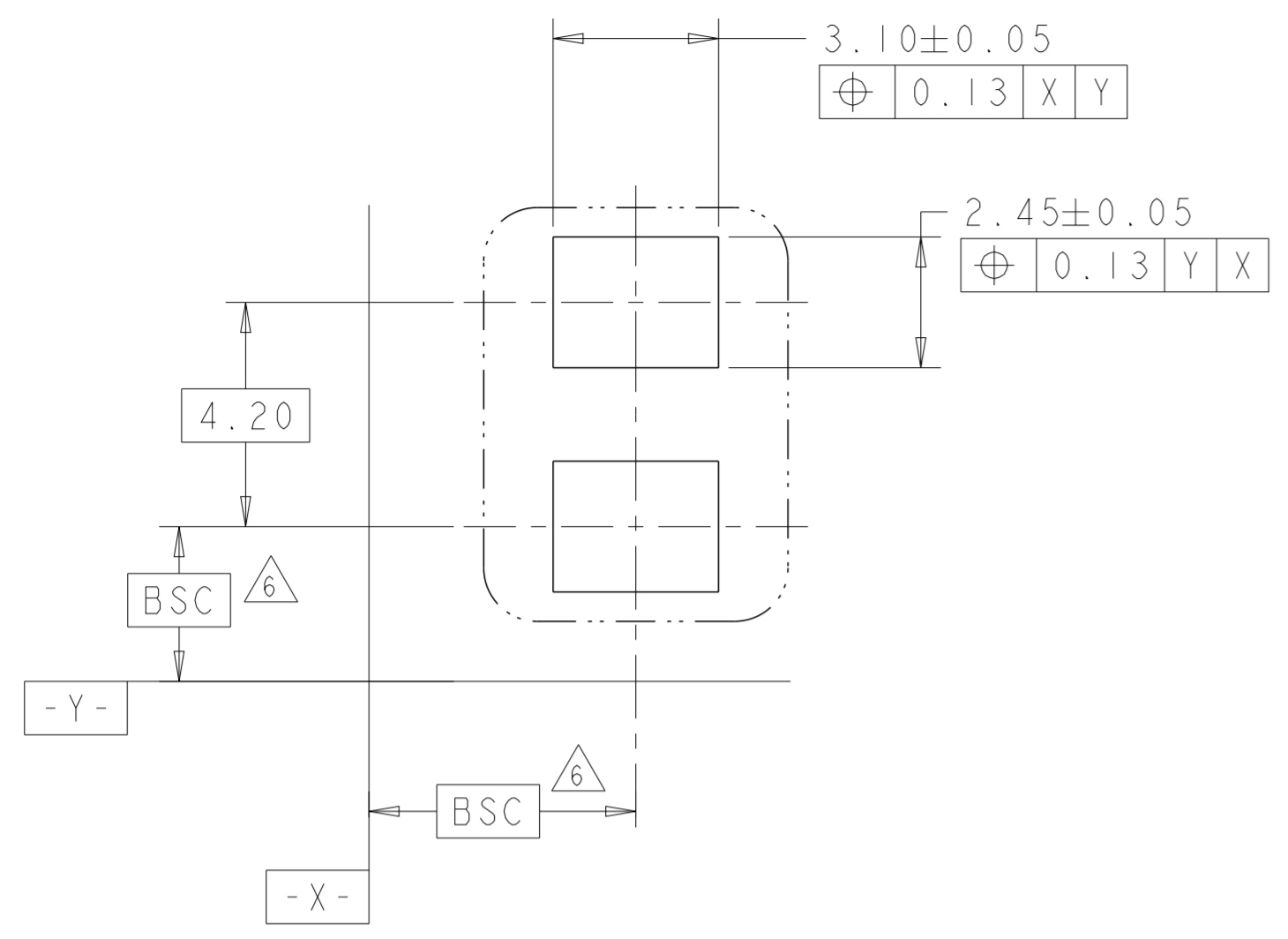

1 POSITION  
RECOMMENDED PAD LAYOUT  
SCALE 8:1

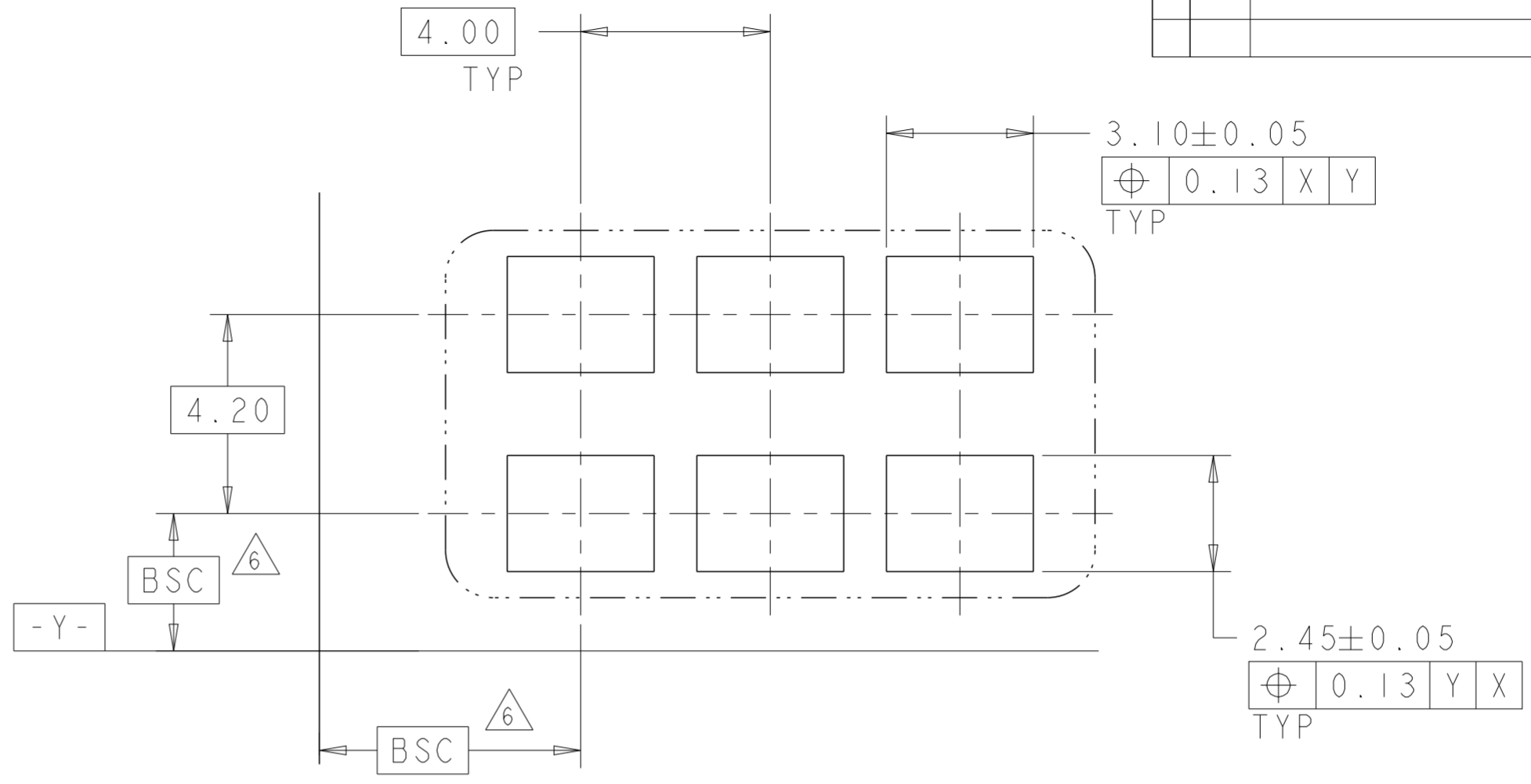

3 POSITION  
RECOMMENDED PAD LAYOUT  
SCALE 8:1

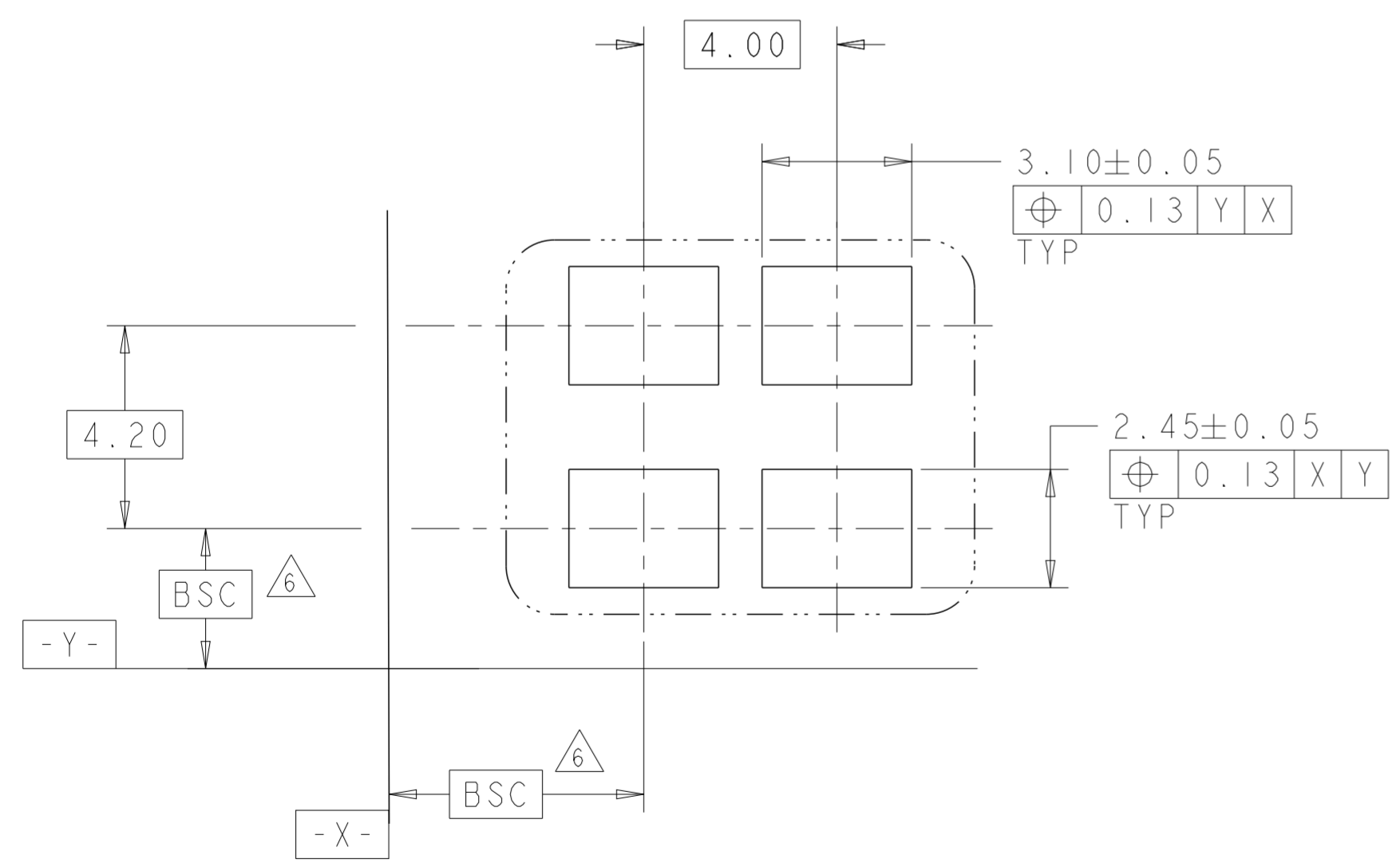

2 POSITION  
RECOMMENDED PAD LAYOUT  
SCALE 8:1

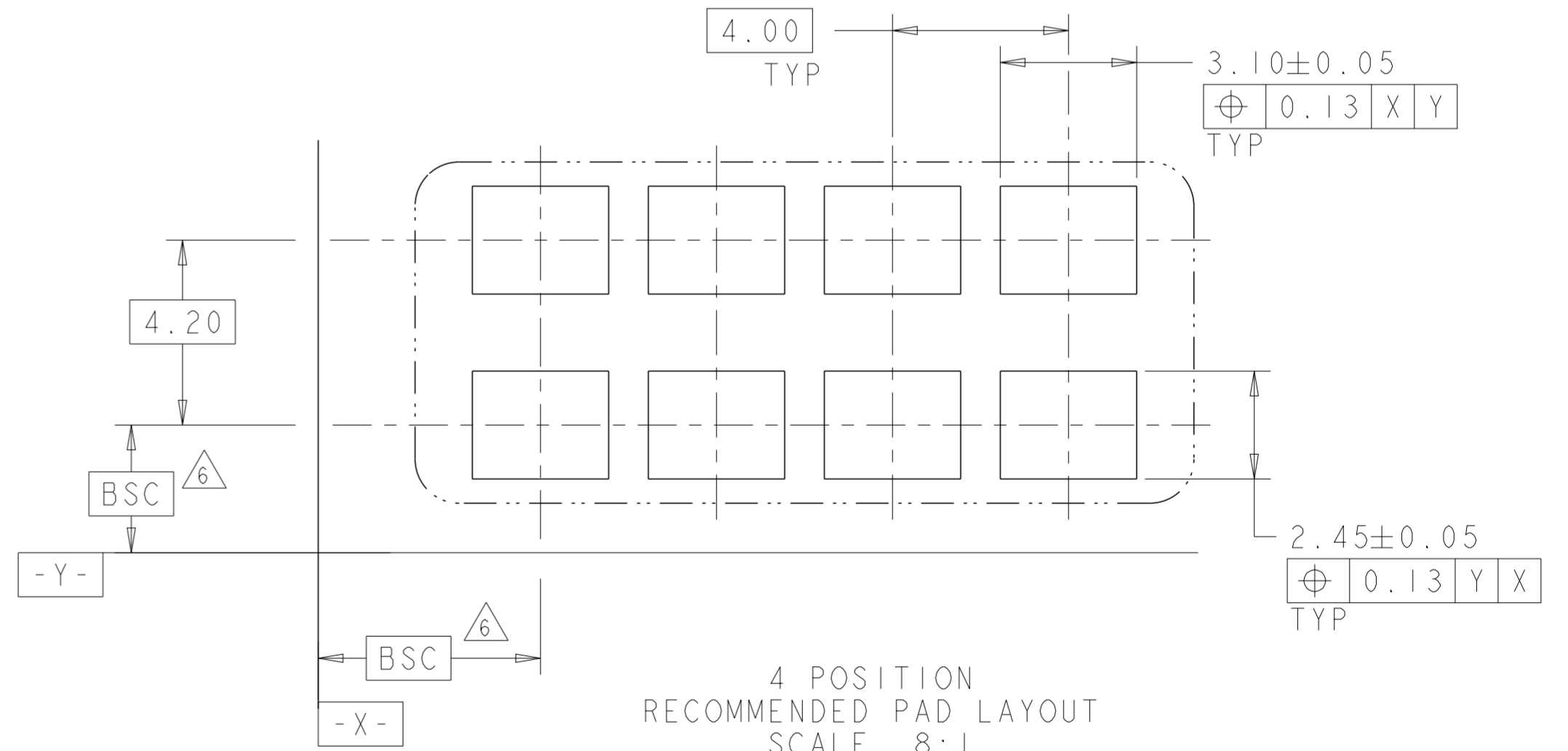

4 POSITION  
RECOMMENDED PAD LAYOUT  
SCALE 8:1

THIS DRAWING IS A CONTROLLED DOCUMENT.		DWN C DAILY 09DEC2008	<b>STE</b> TE Connectivity															
		CHK J DYER 09DEC2008																
DIMENSIONS: mm		TOLERANCES UNLESS OTHERWISE SPECIFIED:		APVD -														
<table border="0"> <tr><td>0 PLC</td><td>±</td></tr> <tr><td>1 PLC</td><td>±0.5</td></tr> <tr><td>2 PLC</td><td>±0.13</td></tr> <tr><td>3 PLC</td><td>±</td></tr> <tr><td>4 PLC</td><td>±</td></tr> <tr><td>ANGLES</td><td>±</td></tr> <tr><td>FINISH</td><td>-</td></tr> </table>		0 PLC	±	1 PLC	±0.5	2 PLC	±0.13	3 PLC	±	4 PLC	±	ANGLES	±	FINISH	-	PRODUCT SPEC 108-2404	NAME ASSEMBLY, IDC SSL CONNECTOR, SMT, PASS THRU	
0 PLC	±																	
1 PLC	±0.5																	
2 PLC	±0.13																	
3 PLC	±																	
4 PLC	±																	
ANGLES	±																	
FINISH	-																	
MATERIAL material_2		APPLICATION SPEC 114-13266	SIZE A200779	CAGE CODE C-2106431														
finish_spec_2		WEIGHT -	DRAWING NO -	RESTRICTED TO -														
Customer Drawing		SCALE 8:1	SHEET 1 OF 3	REV C														

THIS DRAWING IS UNPUBLISHED. RELEASED FOR PUBLICATION 20  
 © COPYRIGHT 20 BY - ALL RIGHTS RESERVED.

LOC	DIST	REVISIONS				
P	LTR	DESCRIPTION	DATE	DWN	APVD	
-	-	SEE SHEET 1	-	-	-	

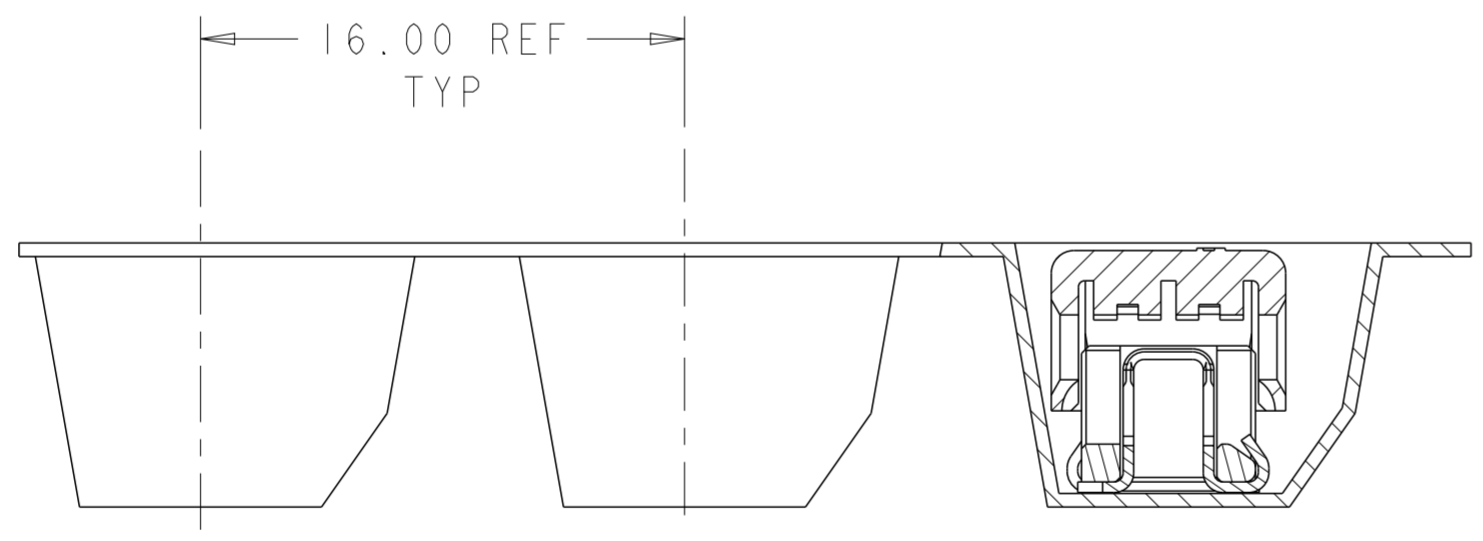
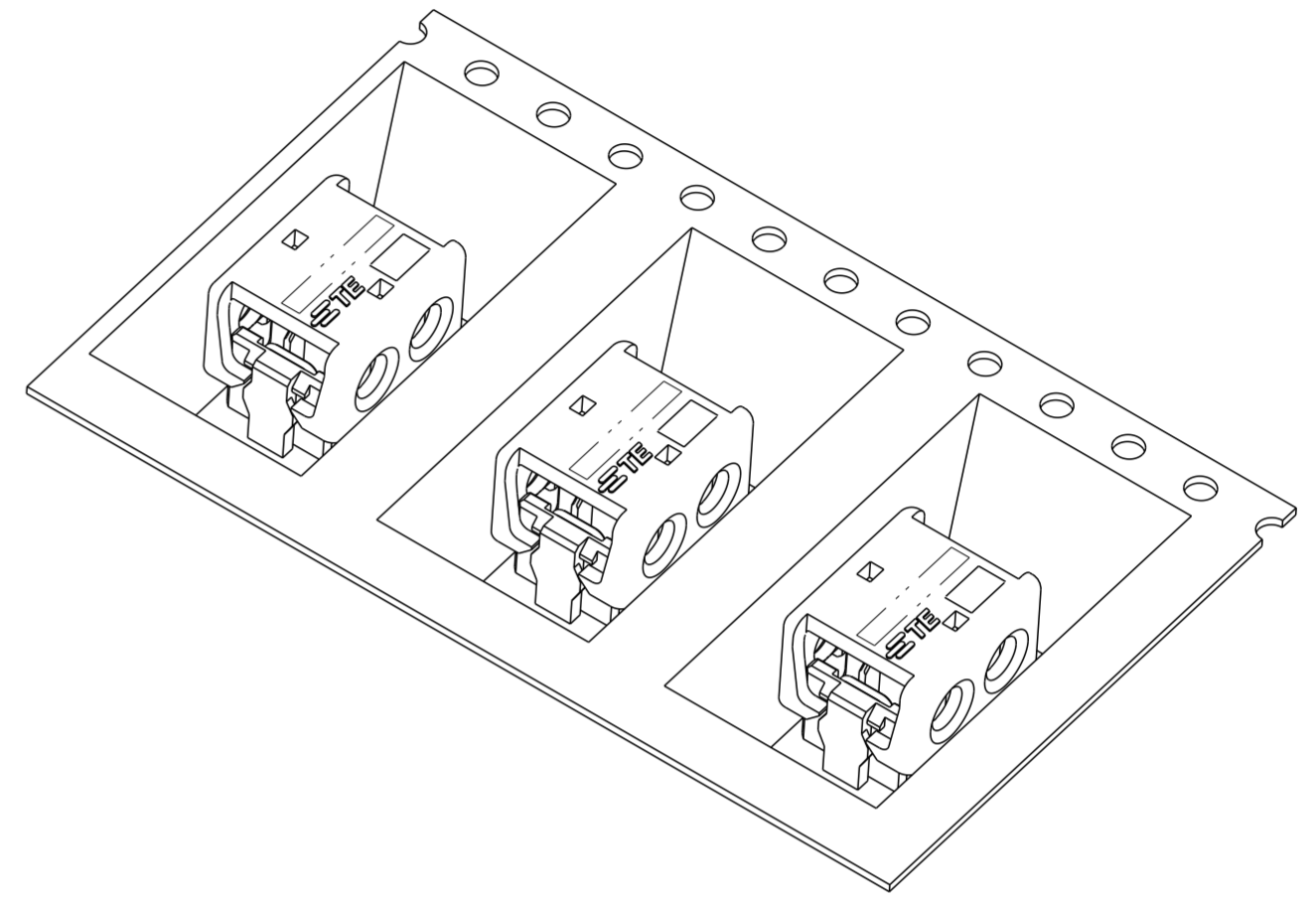
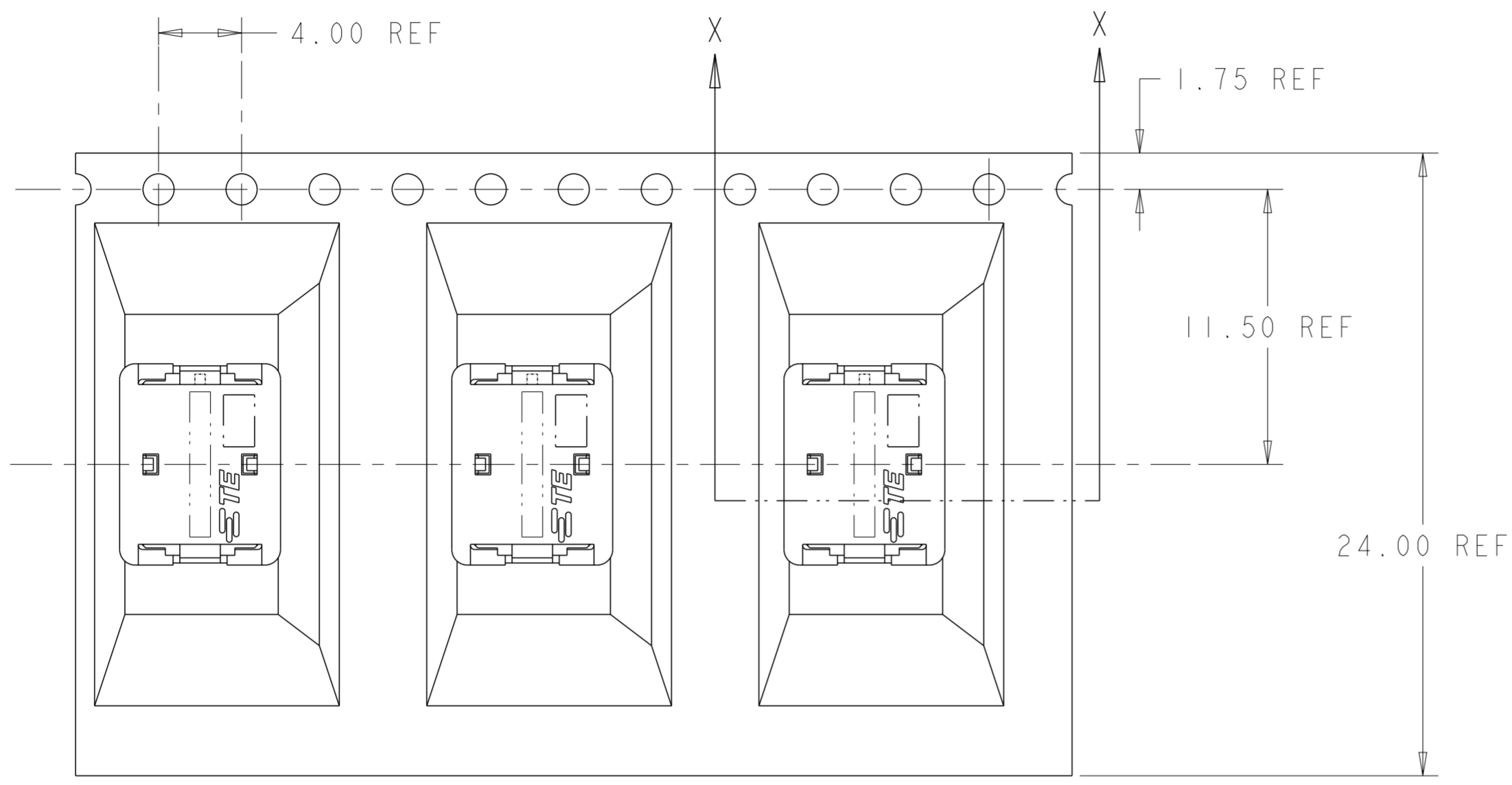

SECTION X-X

2106431-2 SHOWN IN POCKET TAPE

THIS DRAWING IS A CONTROLLED DOCUMENT.		DWN C DAILY 09DEC2008	 TE Connectivity	
		CHK J DYER 09DEC2008		
DIMENSIONS:	TOLERANCES UNLESS OTHERWISE SPECIFIED:	APVD -	NAME ASSEMBLY, IDC SSL CONNECTOR, SMT, PASS THRU	
mm	0 PLC ± 1 PLC ±0.5 2 PLC ±0.13 3 PLC ± 4 PLC ±	PRODUCT SPEC 108-2404	SIZE A200779	
MATERIAL	FINISH	APPLICATION SPEC 114-13266	CAGE CODE C-2106431	DRAWING NO
material_2	finish_spec_2	WEIGHT -	RESTRICTED TO -	
Customer Drawing		SCALE 8:1	SHEET 1	OF 3
		REV C		

# Mouser Electronics

Authorized Distributor

Click to View Pricing, Inventory, Delivery & Lifecycle Information:

[TE Connectivity:](#)

[2-2106431-3](#)