



PRODUCT SPECIFICATION

Model No : CSM-57031V9/CSM-57041V9

Descriptions:

- 0.7Inch Dot-Matrix Display
- 5*7 Array with X-Y Select.
- CSM-57031: Column Anode, Row Cathode
- CSM-57041: Column Cathode, Row Anode
- Emitting Color: Super-Bright Orange



CUSTOMER APPROVED SIGNATURES	APPROVED BY	CHECKED BY	PREPARED BY

CHINA SEMICONDUCTOR CORPORATION

Address:2FL. NO.909,Chung-Cheng Road,
Chung-Ho City Taipei Hsien,Taiwan.

Tel:886-2-2223-9696
Fax:886-2-2223-9377

OPTO PLUS TECHNOLOGIES CO.,LTD

Address:696 Shun jiang Rd.,Ji Shan St.Shaoxing,
ZheJiang,China

Tel:86-0575-88623888
Fax:86-0575-88623112



Spec. No.	PS-ND-0710
Rev.	A

Model No : CSM-57031V9/CSM-57041V9

■ Features -

1. 0.7 inch (17.2mm) Matrix height.
2. Case mold type.
3. RoHs compliant.
4. Low power consumption.
5. Easy mounting on P.C. board or socket.

■ Device Selection Guide -

Part No.	Chip		Description	
	Material	Emitted Color	Column	Row
CSM-57031V9	AlGaInP	Super-Bright Orange	Anode	Cathode
CSM-57041V9			Cathode	Anode

■ Package Dimensions -

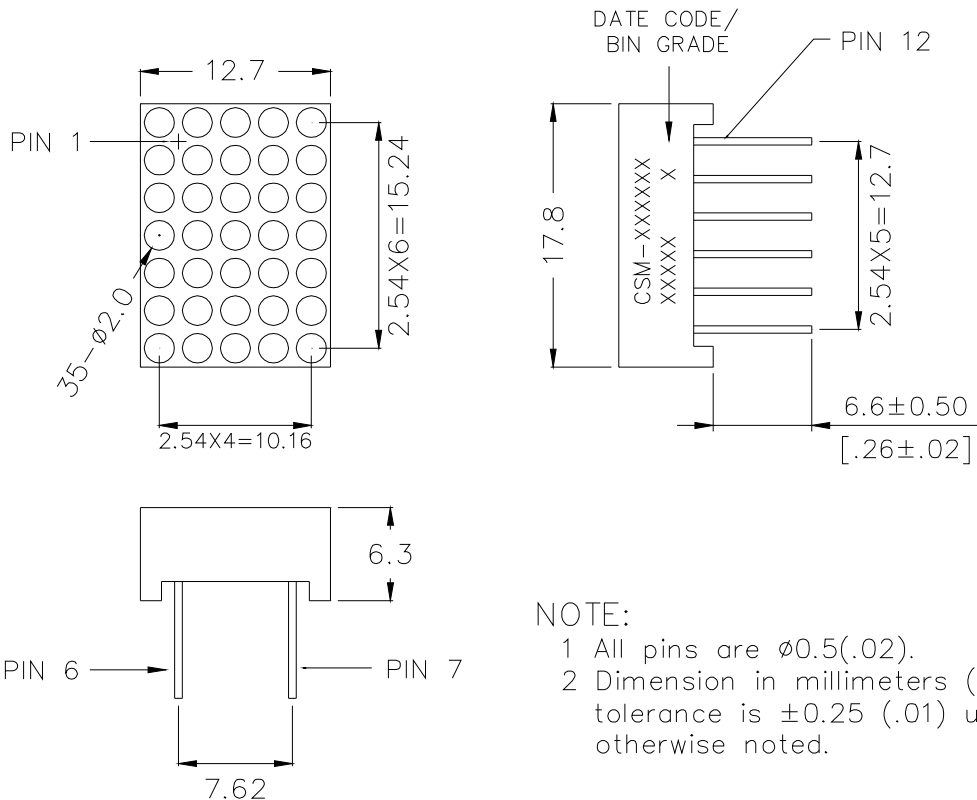

NOTE:
 1 All pins are $\phi 0.5(.02)$.
 2 Dimension in millimeters (inch), tolerance is $\pm 0.25 (.01)$ unless otherwise noted.



Model No : CSM-57031V9/CSM-57041V9

Internal Circuit Diagrams -

CSM-57031

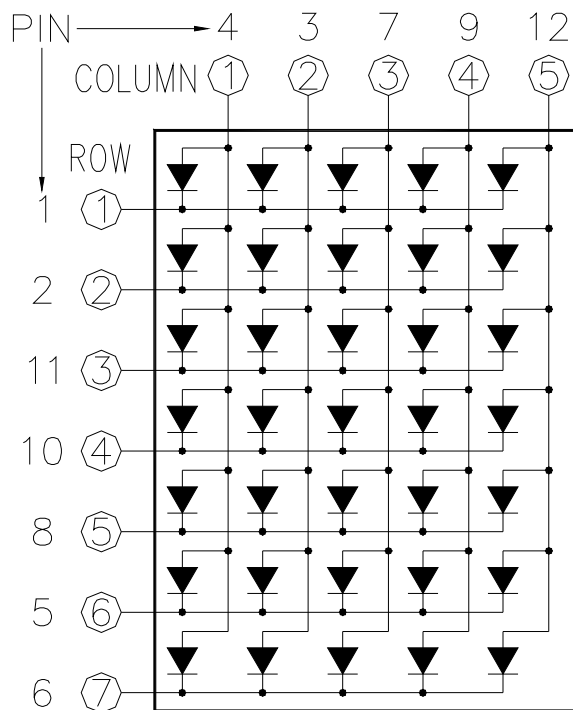

CSM-57031				CSM-57041			
PIN NO.	FUNCTION	PIN NO.	FUNCTION	PIN NO.	FUNCTION	PIN NO.	FUNCTION
1	Cathode Row 1	7	Anode Column 3	1	Anode Row 1	7	Cathode Column 3
2	Cathode Row 2	8	Cathode Row 5	2	Anode Row 2	8	Anode Row 5
3	Anode Column 2	9	Anode Column 4	3	Cathode Column 2	9	Cathode Column 4
4	Anode Column 1	10	Cathode Row 4	4	Cathode Column 1	10	Anode Row 4
5	Cathode Row 6	11	Cathode Row 3	5	Anode Row 6	11	Anode Row 3
6	Cathode Row 7	12	Anode Column 5	6	Anode Row 7	12	Cathode Column 5



Model No : CSM-57031V9/CSM-57041V9

■ Absolute Maximum Rating -

(Ta=25°C)

Parameter	Symbol	Rating	Unit
Power Dissipation Per Dice	P _{AD}	70	mW
Continuous Forward Current Per Dice	I _{AF}	25	mA
Peak Current Per Dice(duty cycle 1/10, 1kHz)	I _{PF}	90	mA
Derating Linear From 25°C Per Dice	-	0.33	mA/°C
Reverse Voltage Per Dice	V _R	5	V
Operating Temp.	T _{opr}	-35 ~ +85	°C
Storage Temp.	T _{stg}	-35 ~ +85	°C
Solder temperature 1/16 inch below seating plane for 3 seconds at 260°C			

■ Electro-optical Characteristics -

(Ta=25°C)

Parameter	Symbol	Min.	Typ.	Max.	Unit	Condition
Forward Voltage Per Dot	V _F	-	2.1	2.8	V	I _F =20mA
Luminous Intensity Per Dot	I _v	-	20	-	mcd	I _F =10mA
Peak Emission Wavelength	λ _p	-	632	-	nm	I _F =20mA
Dominant Wavelength	λ _d	-	624	-	nm	I _F =20mA
Spectrum Radiation Bandwidth	Δλ	-	20	-	nm	I _F =20mA
Reverse Current	I _R	-	-	100	μA	V _R =5V
Luminous Intensity Matching Ratio	I _{V-m}	-	-	2:1		I _p =80mA 1/16Duty



Spec. No.	PS-ND-0710
Rev.	A

Model No : CSM-57031V9/CSM-57041V9

■ Typical Electrical / Optical Characteristics Curves -

(Ta = 25°C Unless Otherwise Noted)

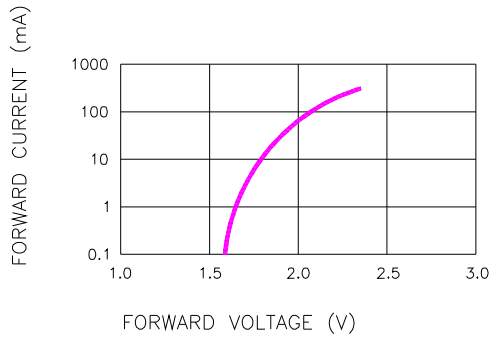

Fig.1 FORWARD CURRENT VS. FORWARD VOLTAGE

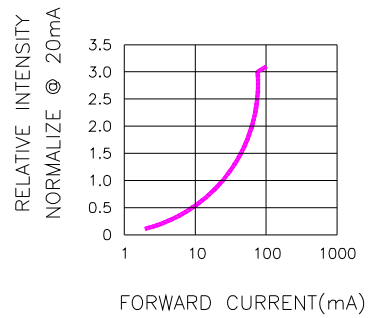

Fig.2 RELATIVE INTENSITY VS. FORWARD CURRENT

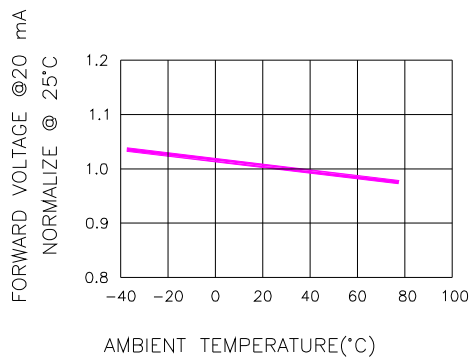

Fig.3 FORWARD VOLTAGE VS. TEMPERATURE

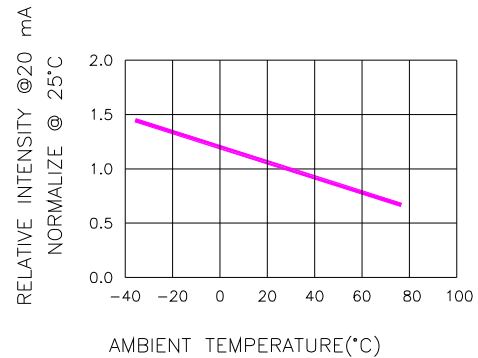

Fig.4 RELATIVE INTENSITY VS. TEMPERATURE

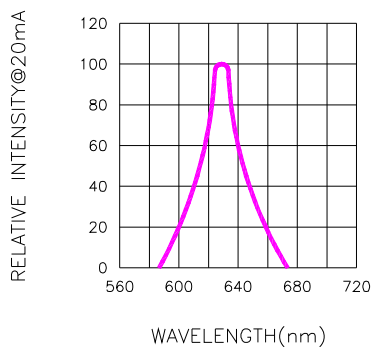

Fig.5 RELATIVE INTENSITY VS. WAVELENGTH



Spec. No.	PS-ND-0710
Rev.	A

Model No : CSM-57031V9/CSM-57041V9

■ Package Dimensions

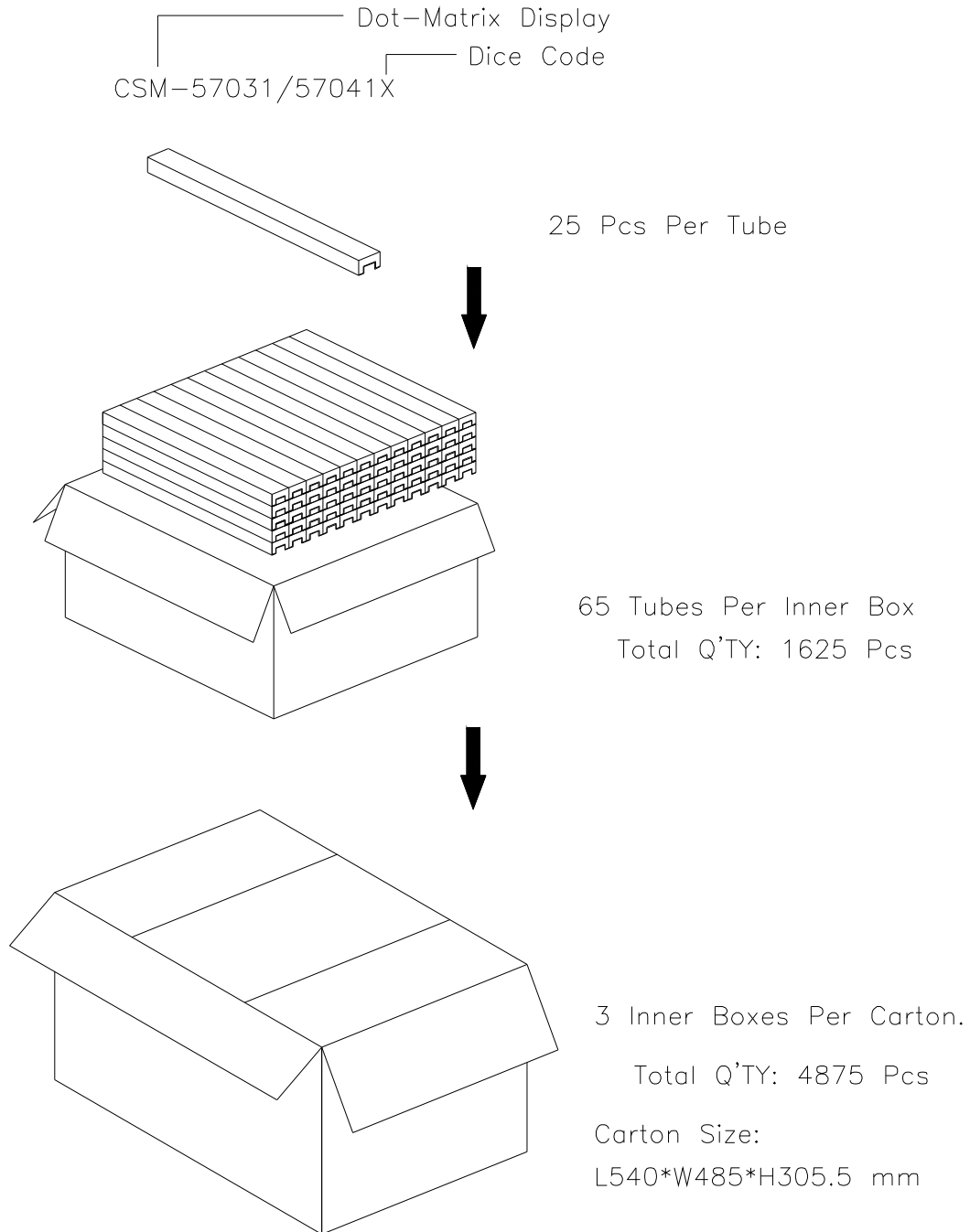

Note: The specifications are subject to change without notice. Please contact us for updated information.