

H
G
F
E
D
C
B
A

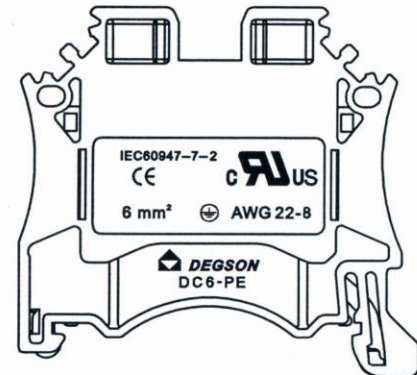

仅供参考图
签字: 蓝贵A
日期: 2017.12.11

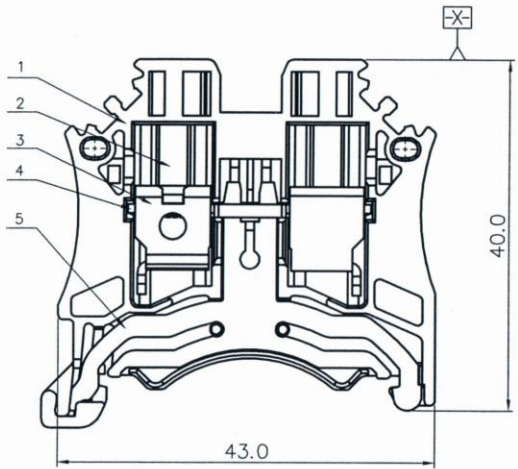

REVISION RECORD				
REV	ECN	DESCRIPTION	DRFT	DATE

NOTES1:
UL Standard
1.Torque value : M4 , 14Lb.in
2.Wire range : 22~8AWG

IEC Standard

1.

Pollution degree	3
Overtoltage category	III
Rate impulse voltage(KV)	8.0KV
Rate voltage(V)	/ V
Rate current(A)	/ A

2.Torque value : M4 , 1.2N·m
3.Wire range : 0.5~6mm²

NOTES2:
1.Dimension shall be interpreted per ASME Y14.5-2009
2.Stripping length : 10~12mm
3.Operating temperature: -40°C~+105°C
4.Undimensioned tolerances:

Pitch Range In mm		Nominal Dimension Range In mm					-	∩	□
Over TO	Over TO	Over TO	Over TO	Over TO	Over TO	0.1/10	∩	□	
6 TO 6	10 TO 10	24 TO 24	30 TO 30	60 TO 60	100 TO 100	150 TO 150	<		
±0.15	±0.20	±0.30	±0.30	±0.50	±0.70	±1.00	±1.30	±2'	

5.RoHS Compliance

ITEM	NAME OF PART	MATERIAL	NOTES
5	CURRENT CONTACT	COPPER ALLOY	Sn PLATED
4	CURRENT CARRIER	COPPER	Sn PLATED
3	CAGE	STEEL	M4/Zn PLATED
2	SCREW	STEEL	M4/Zn PLATED
1	HOUSING	PA66	UL94V-0

DETACHED LISTS	PART NO.: /	宁波高松电子有限公司 NINGBO DEGSON ELECTRICAL CO., LTD		
	APPD:	NAME: DC6-PE-01P-1C-00A(H)		
	CHKD: Alan 2017.12.11	TITLE: CUSTOMER DRAWING		
	DRFT: XMY 10/29/15"	REV: T0-1	SHEET: 1/1	SCALE: 1:1
	 THIRD ANGLE PROJECTION	 DO NOT SCALE DRAWING	MM (INCH)	SCALE: 1:1