



The following document contains information on Cypress products. Although the document is marked with the name "Broadcom", the company that originally developed the specification, Cypress will continue to offer these products to new and existing customers.

CONTINUITY OF SPECIFICATIONS

There is no change to this document as a result of offering the device as a Cypress product. Any changes that have been made are the result of normal document improvements and are noted in the document history page, where supported. Future revisions will occur when appropriate, and changes will be noted in a document history page.

CONTINUITY OF ORDERING PART NUMBERS

Cypress continues to support existing part numbers. To order these products, please use only the Ordering Part Numbers listed in this document.

FOR MORE INFORMATION

Please visit our website at www.cypress.com or contact your [local sales office](#) for additional information about Cypress products and services.

OUR CUSTOMERS

Cypress is for true innovators – in companies both large and small.

Our customers are smart, aggressive, out-of-the-box thinkers who design and develop game-changing products that revolutionize their industries or create new industries with products and solutions that nobody ever thought of before.

ABOUT CYPRESS

Founded in 1982, Cypress is the leader in advanced embedded system solutions for the world's most innovative automotive, industrial, home automation and appliances, consumer electronics and medical products. Cypress's programmable systems-on-chip, general-purpose microcontrollers, analog ICs, wireless and USB-based connectivity solutions and reliable, high-performance memories help engineers design differentiated products and get them to market first.

Cypress is committed to providing customers with the best support and engineering resources on the planet enabling innovators and out-of-the-box thinkers to disrupt markets and create new product categories in record time. To learn more, go to www.cypress.com.



Single-Chip 5G WiFi IEEE 802.11ac MAC/Baseband/Radio with Integrated Bluetooth 4.1 and FM Receiver

GENERAL DESCRIPTION

The Broadcom[®] BCM4339 single-chip device provides the highest level of integration for a mobile or handheld wireless system with integrated single-stream IEEE 802.11ac MAC/baseband/radio, Bluetooth 4.1 and FM radio receiver. In IEEE 802.11ac mode, the WLAN operation supports rates of MCS0–MCS9 (up to 256 QAM) in 20 MHz, 40 MHz, and 80 MHz channels for data rates up to 433.3 Mbps. In addition, all the rates specified in IEEE 802.11a/b/g/n are supported. Included on-chip are 2.4 GHz and 5 GHz transmit amplifiers, and receive low-noise amplifiers. Optional external PAs, LNAs, and antenna diversity are also supported.

For the WLAN section, several alternative host interface options are included: an SDIO v3.0 interface that can operate in 4b, 1b, or gSPI modes and a PCIe Gen1 interface (3.0 compliant). For the Bluetooth section, host interface options of a high-speed 4-wire UART and USB 2.0 full-speed (12 Mbps) are provided.

GENERAL DESCRIPTION

Using advanced design techniques and process technology to reduce active and idle power, the BCM4339 is designed to address the needs of mobile devices that require minimal power consumption and compact size. It includes a power management unit which simplifies the system power topology and allows for direct operation from a mobile platform battery while maximizing battery life.

The BCM4339 implements highly sophisticated enhanced collaborative coexistence hardware mechanisms and algorithms, which ensure that WLAN and Bluetooth collaboration is optimized for maximum performance. In addition, coexistence support for external radios (such as LTE cellular, GPS, and WiMAX) is provided via an external interface. As a result, enhanced overall quality for simultaneous voice, video, and data transmission is achieved.

Figure 1: Functional Block Diagram

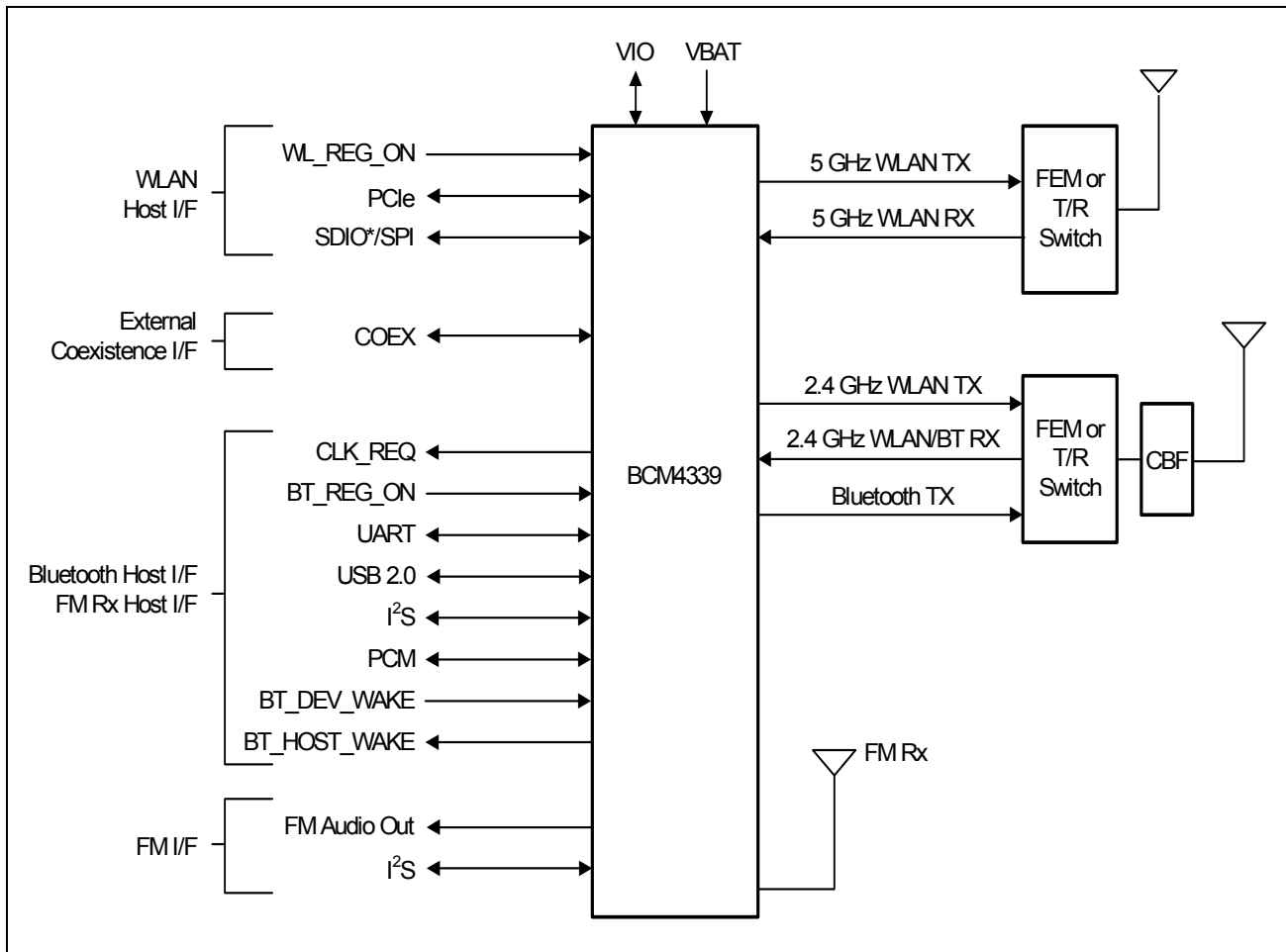

Broadcom Corporation
 5300 California Avenue
 Irvine, CA 92617

© 2014 by Broadcom Corporation
 All rights reserved
 Printed in the U.S.A.

Broadcom®, the pulse logo, Connecting everything®, and the Connecting everything logo are among the trademarks of Broadcom Corporation and/or its affiliates in the United States, certain other countries and/or the EU. Any other trademarks or trade names mentioned are the property of their respective owners.

This data sheet (including, without limitation, the Broadcom component(s) identified herein) is not designed, intended, or certified for use in any military, nuclear, medical, mass transportation, aviation, navigations, pollution control, hazardous substances management, or other high-risk application. BROADCOM PROVIDES THIS DATA SHEET "AS-IS," WITHOUT WARRANTY OF ANY KIND. BROADCOM DISCLAIMS ALL WARRANTIES, EXPRESSED AND IMPLIED, INCLUDING, WITHOUT LIMITATION, THE IMPLIED WARRANTIES OF MERCHANTABILITY, FITNESS FOR A PARTICULAR PURPOSE, AND NON-INFRINGEMENT.

FEATURES**IEEE 802.11x Key Features**

- IEEE 802.11ac compliant.
- Single-stream spatial multiplexing up to 433.3 Mbps data rate.
- Supports 20, 40, and 80 MHz channels with optional SGI (256 QAM modulation).
- Full IEEE 802.11a/b/g/n legacy compatibility with enhanced performance.
- Tx and Rx low-density parity check (LDPC) support for improved range and power efficiency.
- Supports Rx space-time block coding (STBC)
- Supports IEEE 802.11ac/n beamforming.
- On-chip power amplifiers and low-noise amplifiers for both bands.
- Support for optional front-end modules (FEM) with external PAs and LNAs
- Shared Bluetooth and WLAN receive signal path eliminates the need for an external power splitter while maintaining excellent sensitivity for both Bluetooth and WLAN.
- Internal fractional nPLL allows support for a wide range of reference clock frequencies
- Supports IEEE 802.15.2 external coexistence interface to optimize bandwidth utilization with other co-located wireless technologies such as LTE, GPS, or WiMAX
- Supports standard SDIO v3.0 (including DDR50 mode at 50 MHz and SDR104 mode at 208 MHz, 4-bit and 1-bit), and gSPI (48 MHz) host interfaces.
- Backward compatible with SDIO v2.0 host interfaces.
- PCIe mode (FCBGA package only) complies with PCI Express base specification revision 3.0 compliant Gen1 interface for ×1 lane and power management base specification.

FEATURES

- Integrated ARMCR4™ processor with tightly coupled memory for complete WLAN subsystem functionality, minimizing the need to wake up the applications processor for standard WLAN functions. This allows for further minimization of power consumption, while maintaining the ability to field upgrade with future features. On-chip memory includes 768 KB SRAM and 640 KB ROM.
- OneDriver™ software architecture for easy migration from existing embedded WLAN and Bluetooth devices as well as future devices.

Bluetooth and FM Key Features

- Complies with Bluetooth Core Specification Version 4.1 with provisions for supporting future specifications.
- Bluetooth Class 1 or Class 2 transmitter operation.
- Supports extended synchronous connections (eSCO), for enhanced voice quality by allowing for retransmission of dropped packets.
- Adaptive frequency hopping (AFH) for reducing radio frequency interference.
- Interface support, host controller interface (HCI) using a USB or high-speed UART interface and PCM for audio data.
- USB 2.0 full-speed (12 Mbps) supported (FCFBGA and WLCSP packages).
- The FM unit supports HCI for communication.
- Low power consumption improves battery life of handheld devices.
- FM receiver: 65 MHz to 108 MHz FM bands; supports the European radio data systems (RDS) and the North American radio broadcast data system (RBDS) standards.
- Supports multiple simultaneous Advanced Audio Distribution Profiles (A2DP) for stereo sound.
- Automatic frequency detection for standard crystal and TCXO values.
- Supports serial flash interfaces.

FEATURES**General Features**

- Supports battery voltage range from 3.0V to 5.25V supplies with internal switching regulator.
- Programmable dynamic power management
- OTP: 502 bytes of user-accessible memory
- GPIOs: 12 on FCFBGA, nine on WLBGA, and 16 on WLCSP
- Package options:
 - 160 ball FCFBGA (8 mm x 8 mm, 0.4 mm pitch)
 - 145 ball WLBGA (4.87 mm x 5.413 mm, 0.4 mm pitch)
 - 286 bump WLCSP (4.87 mm x 5.413 mm, 0.2 mm pitch)

FEATURES

- Security:
 - WPA™ and WPA2™ (Personal) support for powerful encryption and authentication
 - AES and TKIP in hardware for faster data encryption and IEEE 802.11i compatibility
 - Reference WLAN subsystem provides Cisco® Compatible Extensions (CCX, CCX 2.0, CCX 3.0, CCX 4.0, CCX 5.0)
 - Reference WLAN subsystem provides Wi-Fi Protected Setup (WPS)
- Worldwide regulatory support: Global products supported with worldwide homologated design.

Revision History

Revision	Date	Change Description
4339-DS106-R	11/17/14	Updated: <ul style="list-style-type: none">• Table 55: "SDIO Bus Input Timing Parameters (SDR Modes)," on page 163.
4339-DS105-R	05/28/14	Updated: <ul style="list-style-type: none">• The Features listed in the front matter of the document.• By changing all instances of Bluetooth 4.0 to Bluetooth 4.1 throughout the document.• By removing the word draft after all instances of IEEE 802.11ac throughout the document.• "Features" on page 22.• "External 32.768 kHz Low-Power Oscillator" on page 34.• "Advanced Bluetooth/WLAN Coexistence" on page 46.• "SDIO v3.0" on page 73.• Table 20: "FCFBGA, WLBGA, and WLCSP Signal Descriptions," on page 105 by fixing an incorrect WLBGA ball. The second instance of M12 was changed to M10.• Table 21: "WLAN GPIO Functions and Strapping Options," on page 114.• Table 24: "Host Interface Selection (WLBGA and WLCSP Packages)," on page 115

Revision	Date	Change Description
4339-DS104-R	04/02/14	<p>Updated:</p> <ul style="list-style-type: none"> • The cover page and the general features on page 6. • By deleting the HSIC interface throughout, leaving pin and signal names unchanged. • By changing to <i>PCI Express Base Specification</i> (revision 3.0 compliant Gen1 interface) throughout. • “External Frequency Reference” on page 37. • Table 2: “Crystal Oscillator and External Clock — Requirements and Performance,” on page 37. • “Frequency Selection” on page 39. • Figure 10: “Startup Signaling Sequence,” on page 48. • Figure 22: “UART Timing,” on page 66. • “One-Time Programmable Memory” on page 76. • Figure 50: “160-Ball FCFBGA (Top View),” on page 103 by changing BT_VDDO to BT_VDDIO. • Figure 54: “286-Bump WLCSP (Bottom View),” on page 107. • Table 19: “286-Bump WLCSP Coordinates,” on page 108 by changing BT_VDDO to BT_VDDIO. • Table 20: “FCFBGA, WLBGA, and WLCSP Signal Descriptions,” on page 117 by changing BT_VDDO to BT_VDDIO and adding a note to the GPIO pin description. • Table 31: “I/O States,” on page 134. • Table 34: “ESD Specifications,” on page 139. • Table 35: “Recommended Operating Conditions and DC Characteristics,” on page 140 by changing C_{IN} to C_{OUT}. • Table 36: “Bluetooth Receiver RF Specifications,” on page 144 by deleting what was footnote e, altering footnote b, and adding footnote b to one additional place. • “Introduction” on page 155. • RSSI accuracy in Table 42: “WLAN 2.4 GHz Receiver Performance Specifications,” on page 157 and Table 44: “WLAN 5 GHz Receiver Performance Specifications,” on page 164. • Table 43: “WLAN 2.4 GHz Transmitter Performance Specifications,” on page 162 and the note preceding it. • Table 45: “WLAN 5 GHz Transmitter Performance Specifications,” on page 168 and the note preceding it. • Section 18: “Internal Regulator Electrical Specifications,” on page 170. • “WLAN Current Consumption” on page 175. • Figure 65: “SDIO Bus Output Timing (SDR Modes up to 100 MHz),” on page 183. • Figure 66: “SDIO Bus Output Timing (SDR Modes 100 MHz to 208 MHz),” on page 183.
4339-DS103-R	11/08/13	<p>Updated:</p> <ul style="list-style-type: none"> • BT_VDDO to BT_VDDIO throughout the document. • Table 34: “ESD Specifications,” on page 140.

Revision	Date	Change Description
4339-DS102-R	07/02/13	<p>Updated:</p> <ul style="list-style-type: none"> • Figure 1: “Functional Block Diagram,” on page 2. • Figure 2: “BCM4339 Block Diagram,” on page 22. • Figure 5: “Typical Power Topology for BCM4339,” on page 29. • Table 20: “FCFBGA, WLBGA, and WLCSP Signal Descriptions,” on page 118. • Table 35: “Recommended Operating Conditions and DC Characteristics,” on page 141 by changing DC supply voltage for VBAT from 4.8V to 5.25V. • Table 47: “Core Buck Switching Regulator (CBLUCK) Specifications,” on page 171 by changing input supply voltage (DC) Max from 4.8V to 5.25V. • Table 48: “LDO3P3 Specifications,” on page 172 by changing input supply voltage, VIN Max from 4.8V to 5.25V. • Table 49: “BTLDO2P5 Specifications,” on page 173 by changing input supply voltage Max from 4.8V to 5.25V. • Table 52: “Typical WLAN Power Consumption (External PA configuration),” on page 176. • Table 53: “Bluetooth BLE and FM Current Consumption,” on page 178. • Section 24: “Ordering Information,” on page 202.
4339-DS101-R	03/12/13	<p>Updated:</p> <ul style="list-style-type: none"> • Package option dimensions on page 4. • Table 19: “286-Bump WLCSP Coordinates,” on page 109 by replacing the PACKAGEOPTION_0 through PACKAGEOPTION_3 signal names with VSSC. • The Power Rail column in Table 31: “I/O States,” on page 135. • Table 32: “Absolute Maximum Ratings,” on page 139. • Table 35: “Recommended Operating Conditions and DC Characteristics,” on page 141. • Table 43: “WLAN 2.4 GHz Transmitter Performance Specifications,” on page 163. • Table 45: “WLAN 5 GHz Transmitter Performance Specifications,” on page 169. • “WLAN Current Consumption” on page 176. • Table 53: “Bluetooth BLE and FM Current Consumption,” on page 178. • Figure 77: “145-Ball WLBGA Package Mechanical Information,” on page 198. • Section 24: “Ordering Information,” on page 202.
4339-DS100-R	02/15/13	Initial release.

Table of Contents

About This Document	18
Purpose and Audience	18
Acronyms and Abbreviations	18
Document Conventions	18
References	18
Technical Support	19
Section 1: Overview	20
Overview	20
Features	22
Standards Compliance	23
Mobile Phone Usage Model	24
Section 2: Power Supplies and Power Management	25
Power Supply Topology	25
PMU Features	25
WLAN Power Management	27
PMU Sequencing	28
Power-Off Shutdown	29
Power-Up/Power-Down/Reset Circuits	29
Section 3: Frequency References	30
Crystal Interface and Clock Generation	30
External Frequency Reference	31
Frequency Selection	33
External 32.768 kHz Low-Power Oscillator	34
Section 4: Bluetooth + FM Subsystem Overview	35
Features	35
Bluetooth Radio	37
Transmit	37
Digital Modulator	37
Digital Demodulator and Bit Synchronizer	37
Power Amplifier	37
Receiver	38
Digital Demodulator and Bit Synchronizer	38
Receiver Signal Strength Indicator	38
Local Oscillator Generation	38
Calibration	38

Section 5: Bluetooth Baseband Core	39
Bluetooth 4.1 Features	39
Bluetooth Low Energy	39
Link Control Layer	40
Test Mode Support	40
Bluetooth Power Management Unit	41
RF Power Management	41
Host Controller Power Management	41
BBC Power Management.....	43
FM Power Management.....	43
Wideband Speech.....	43
Packet Loss Concealment.....	44
Audio Rate-Matching Algorithms.....	44
Codec Encoding	45
Multiple Simultaneous A2DP Audio Streams	45
FM Over Bluetooth	45
Burst Buffer Operation.....	45
Adaptive Frequency Hopping.....	45
Advanced Bluetooth/WLAN Coexistence.....	46
Fast Connection (Interlaced Page and Inquiry Scans)	46
Section 6: Microprocessor and Memory Unit for Bluetooth.....	47
RAM, ROM, and Patch Memory	47
Reset.....	47
Section 7: Bluetooth Peripheral Transport Unit	48
SPI Interface.....	48
SPI/UART Transport Detection.....	48
PCM Interface.....	49
Slot Mapping	49
Frame Synchronization	49
Data Formatting.....	49
Wideband Speech Support	50
Multiplexed Bluetooth and FM Over PCM.....	50
Burst PCM Mode.....	50
PCM Interface Timing.....	51
Short Frame Sync, Master Mode	51
Short Frame Sync, Slave Mode	52
Long Frame Sync, Master Mode.....	53
Long Frame Sync, Slave Mode.....	54

Short Frame Sync, Burst Mode.....	55
Long Frame Sync, Burst Mode	56
USB Interface	57
Features	57
Operation.....	57
USB Hub and UHE Support	58
USB Full-Speed Timing.....	58
UART Interface.....	59
I²S Interface.....	61
I ² S Timing.....	62
Section 8: FM Receiver Subsystem	64
FM Radio	64
Digital FM Audio Interfaces	64
FM Over Bluetooth	64
eSCO.....	64
Wide Band Speech Link.....	65
A2DP	65
Autotune and Search Algorithms	65
Audio Features	66
RDS/RBDS.....	69
Section 9: WLAN Global Functions	70
WLAN CPU and Memory Subsystem.....	70
One-Time Programmable Memory	70
GPIO Interface.....	71
External Coexistence Interface	71
UART Interface.....	72
JTAG Interface	72
SPROM Interface (FCBGA Package only)	72
Section 10: WLAN Host Interfaces.....	73
SDIO v3.0.....	73
SDIO Pins.....	73
Generic SPI Mode	75
SPI Protocol	76
Command Structure	77
Write.....	77
Write/Read	77
Read.....	77
Status.....	78

gSPI Host-Device Handshake.....	80
Boot-Up Sequence.....	80
PCI Express Interface (FCBGA Package Only).....	83
Transaction Layer Interface.....	84
Data Link Layer.....	84
Physical Layer.....	84
Logical Subblock.....	84
Scrambler/Descrambler.....	84
8B/10B Encoder/Decoder.....	85
Elastic FIFO.....	85
Electrical Subblock.....	85
Configuration Space.....	85
Section 11: Wireless LAN MAC and PHY.....	86
IEEE 802.11ac MAC.....	86
PSM.....	87
WEP.....	87
TXE.....	88
RXE.....	88
IFS.....	88
TSF.....	89
NAV.....	89
MAC-PHY Interface.....	89
IEEE 802.11ac PHY.....	90
Section 12: WLAN Radio Subsystem.....	92
Receiver Path.....	92
Transmit Path.....	92
Calibration.....	92
Section 13: Pinout and Signal Descriptions.....	94
Ball Maps.....	94
Pin Lists.....	97
Signal Descriptions.....	105
WLAN GPIO Signals and Strapping Options.....	114
Multiplexed Bluetooth GPIO Signals.....	116
GPIO/SDIO Alternative Signal Functions.....	118
I/O States.....	119
Section 14: DC Characteristics.....	122
Absolute Maximum Ratings.....	122
Environmental Ratings.....	123

Electrostatic Discharge Specifications	123
Recommended Operating Conditions and DC Characteristics	124
Section 15: Bluetooth RF Specifications	126
Section 16: FM Receiver Specifications	133
Section 17: WLAN RF Specifications	138
Introduction.....	138
2.4 GHz Band General RF Specifications.....	138
WLAN 2.4 GHz Receiver Performance Specifications	139
WLAN 2.4 GHz Transmitter Performance Specifications	143
WLAN 5 GHz Receiver Performance Specifications	145
WLAN 5 GHz Transmitter Performance Specifications	149
General Spurious Emissions Specifications	150
Section 18: Internal Regulator Electrical Specifications	151
Core Buck Switching Regulator.....	151
3.3V LDO (LDO3P3)	152
2.5V LDO (BTLDO2P5)	153
CLDO	154
LNLDO	155
Section 19: System Power Consumption.....	156
WLAN Current Consumption.....	156
Bluetooth and FM Current Consumption	158
Section 20: Interface Timing and AC Characteristics	159
SDIO/gSPI Timing	159
SDIO Default Mode Timing	159
SDIO High-Speed Mode Timing.....	161
SDIO Bus Timing Specifications in SDR Modes	162
Clock Timing	162
Device Input Timing	163
Device Output Timing.....	164
SDIO Bus Timing Specifications in DDR50 Mode.....	166
Data Timing, DDR50 Mode	167
gSPI Signal Timing.....	168
PCI Express Interface Parameters	169
JTAG Timing	171
Section 21: Power-Up Sequence and Timing	172
Sequencing of Reset and Regulator Control Signals	172
Description of Control Signals.....	172

Control Signal Timing Diagrams..... 173

Section 22: Package Information 175

 Package Thermal Characteristics 175

 Junction Temperature Estimation and Ψ_{JT} Versus Θ_{JC} 175

 Environmental Characteristics..... 175

Section 23: Mechanical Information 176

Section 24: Ordering Information 181

List of Figures

Figure 1: Functional Block Diagram	2
Figure 2: BCM4339 Block Diagram	21
Figure 3: Typical Power Topology for BCM4339	26
Figure 4: Recommended Oscillator Configuration	30
Figure 5: Recommended Circuit to Use with an External Reference Clock.....	31
Figure 6: Startup Signaling Sequence	42
Figure 7: CVSD Decoder Output Waveform Without PLC	44
Figure 8: CVSD Decoder Output Waveform After Applying PLC.....	44
Figure 9: Functional Multiplex Data Diagram	50
Figure 10: PCM Timing Diagram (Short Frame Sync, Master Mode)	51
Figure 11: PCM Timing Diagram (Short Frame Sync, Slave Mode)	52
Figure 12: PCM Timing Diagram (Long Frame Sync, Master Mode).....	53
Figure 13: PCM Timing Diagram (Long Frame Sync, Slave Mode).....	54
Figure 14: PCM Burst Mode Timing (Receive Only, Short Frame Sync).....	55
Figure 15: PCM Burst Mode Timing (Receive Only, Long Frame Sync)	56
Figure 16: USB Compounded Device Configuration	57
Figure 17: USB Full-Speed Timing	59
Figure 18: UART Timing	60
Figure 19: I ² S Transmitter Timing.....	63
Figure 20: I ² S Receiver Timing.....	63
Figure 21: Example Blend/Switch Usage.....	66
Figure 22: Example Blend/Switch Separation.....	67
Figure 23: Example Soft Mute Characteristic	68
Figure 24: Broadcom GCI or BT-SIG Mode LTE Coexistence Interface for BCM4339	71
Figure 25: Signal Connections to SDIO Host (SD 4-Bit Mode).....	74
Figure 26: Signal Connections to SDIO Host (SD 1-Bit Mode).....	74
Figure 27: Signal Connections to SDIO Host (gSPI Mode)	75
Figure 28: gSPI Write Protocol	76
Figure 29: gSPI Read Protocol	76
Figure 30: gSPI Command Structure.....	77
Figure 31: gSPI Signal Timing Without Status (32-bit Big Endian)	78
Figure 32: gSPI Signal Timing with Status (Response Delay = 0; 32-bit Big Endian)	79
Figure 33: WLAN Boot-Up Sequence	82
Figure 34: PCI Express Layer Model	83
Figure 35: WLAN MAC Architecture	86

Figure 36: WLAN PHY Block Diagram.....	91
Figure 37: Radio Functional Block Diagram	93
Figure 38: 160-Ball FCFBGA (Top View).....	94
Figure 39: 145-Ball WLBGA (Top View)	95
Figure 40: 286-Bump WLCSP (Bottom View).....	96
Figure 41: Port Locations for Bluetooth Testing.....	126
Figure 42: Port Locations Showing Optional ePA and eLNA (Applies to 2.4 GHz and 5 GHz)	138
Figure 43: SDIO Bus Timing (Default Mode)	159
Figure 44: SDIO Bus Timing (High-Speed Mode).....	161
Figure 45: SDIO Clock Timing (SDR Modes)	162
Figure 46: SDIO Bus Input Timing (SDR Modes)	163
Figure 47: SDIO Bus Output Timing (SDR Modes up to 100 MHz).....	164
Figure 48: SDIO Bus Output Timing (SDR Modes 100 MHz to 208 MHz).....	164
Figure 49: Δ TOP Consideration for Variable Data Window (SDR 104 Mode)	165
Figure 50: SDIO Clock Timing (DDR50 Mode)	166
Figure 51: SDIO Data Timing (DDR50 Mode)	167
Figure 52: gSPI Timing	168
Figure 53: WLAN = ON, Bluetooth = ON	173
Figure 54: WLAN = OFF, Bluetooth = OFF	173
Figure 55: WLAN = ON, Bluetooth = OFF	174
Figure 56: WLAN = OFF, Bluetooth = ON	174
Figure 57: 160-Ball FCFBGA Package Mechanical Information.....	176
Figure 58: 145-Ball WLBGA Package Mechanical Information	177
Figure 59: WLBGA Keep-out Areas for PCB Layout—Bottom View with Balls Facing Up.....	178
Figure 60: 286-Bump WLCSP Package Mechanical Information	179
Figure 61: WLCSP Keep-out Areas for PCB Layout—Bottom View with Bumps Facing Up.....	180

List of Tables

Table 1: Power-Up/Power-Down/Reset Control Signals.....	29
Table 2: Crystal Oscillator and External Clock—Requirements and Performance	31
Table 3: External 32.768 kHz Sleep Clock Specifications	34
Table 4: Power Control Pin Description	41
Table 5: SPI to UART Signal Mapping.....	48
Table 6: PCM Interface Timing Specifications (Short Frame Sync, Master Mode).....	51
Table 7: PCM Interface Timing Specifications (Short Frame Sync, Slave Mode).....	52
Table 8: PCM Interface Timing Specifications (Long Frame Sync, Master Mode)	53
Table 9: PCM Interface Timing Specifications (Long Frame Sync, Slave Mode)	54
Table 10: PCM Burst Mode (Receive Only, Short Frame Sync).....	55
Table 11: PCM Burst Mode (Receive Only, Long Frame Sync)	56
Table 12: USB Full-Speed Timing Specifications	59
Table 13: Example of Common Baud Rates.....	60
Table 14: UART Timing Specifications	60
Table 15: Timing for I ² S Transmitters and Receivers	62
Table 16: SDIO Pin Description	73
Table 17: gSPI Status Field Details	79
Table 18: gSPI Registers	80
Table 19: 286-Bump WLCSP Coordinates	97
Table 20: FCBGA, WLBGA, and WLCSP Signal Descriptions.....	105
Table 21: WLAN GPIO Functions and Strapping Options	114
Table 22: SDIO/gSPI I/O Voltage Selection (All Packages)	114
Table 23: Host Interface Selection (FCBGA Package only)	115
Table 24: Host Interface Selection (WLBGA and WLCSP Packages).....	115
Table 25: OTP/SPROM Select	115
Table 26: GPIO Multiplexing Matrix	116
Table 27: Multiplexed GPIO Signals	117
Table 28: BCM4339 GPIO/SDIO Alternative Signal Functions	118
Table 29: I/O States	119
Table 30: Absolute Maximum Ratings	122
Table 31: Environmental Ratings	123
Table 32: ESD Specifications	123
Table 33: Recommended Operating Conditions and DC Characteristics.....	124
Table 34: Bluetooth Receiver RF Specifications.....	127
Table 35: Bluetooth Transmitter RF Specifications.....	130

Table 36: Local Oscillator Performance	132
Table 37: BLE RF Specifications	132
Table 38: FM Receiver Specifications	133
Table 39: 2.4 GHz Band General RF Specifications.....	138
Table 40: WLAN 2.4 GHz Receiver Performance Specifications	139
Table 41: WLAN 2.4 GHz Transmitter Performance Specifications	143
Table 42: WLAN 5 GHz Receiver Performance Specifications	145
Table 43: WLAN 5 GHz Transmitter Performance Specifications	149
Table 44: General Spurious Emissions Specifications	150
Table 45: Core Buck Switching Regulator (CLOCK) Specifications	151
Table 46: LDO3P3 Specifications	152
Table 47: BTLDO2P5 Specifications	153
Table 48: CLDO Specifications.....	154
Table 49: LNLDO Specifications	155
Table 50: Typical WLAN Current Consumption (BCM4339 Current Only)	156
Table 51: Bluetooth BLE and FM Current Consumption.....	158
Table 52: SDIO Bus Timing Parameters (Default Mode).....	159
Table 53: SDIO Bus Timing Parameters (High-Speed Mode)	161
Table 54: SDIO Bus Clock Timing Parameters (SDR Modes).....	162
Table 55: SDIO Bus Input Timing Parameters (SDR Modes).....	163
Table 56: SDIO Bus Output Timing Parameters (SDR Modes up to 100 MHz).....	164
Table 57: SDIO Bus Output Timing Parameters (SDR Modes 100 MHz to 208 MHz)	165
Table 58: SDIO Bus Clock Timing Parameters (DDR50 Mode)	166
Table 59: SDIO Bus Timing Parameters (DDR50 Mode)	167
Table 60: gSPI Timing Parameters.....	168
Table 61: PCI Express Interface Parameters	169
Table 62: JTAG Timing Characteristics	171
Table 63: Package Thermal Characteristics	175

About This Document

Purpose and Audience

This data sheet provides details on the functional, operational, and electrical characteristics for the Broadcom® BCM4339. It is intended for hardware design, application, and OEM engineers.

Acronyms and Abbreviations

In most cases, acronyms and abbreviations are defined on first use. For a comprehensive list of acronyms and other terms used in Broadcom documents, go to <http://www.broadcom.com/press/glossary.php>.

Document Conventions

The following conventions may be used in this document:

Convention	Description
Bold	User input and actions: for example, type exit , click OK , press ALT+C
Monospace	Code: <code>#include <iostream></code> HTML: <code><td rowspan = 3></code> Command line commands and parameters: <code>w1 [-1] <command></code>
< >	Placeholders for <i>required</i> elements: enter your <username> or w1 <command>
[]	Indicates <i>optional</i> command-line parameters: <code>w1 [-1]</code> Indicates bit and byte ranges (inclusive): <code>[0:3]</code> or <code>[7:0]</code>

References

The references in this section may be used in conjunction with this document.



Note: Broadcom provides customer access to technical documentation and software through its Customer Support Portal (CSP) and Downloads & Support site (see [Technical Support](#)).

For Broadcom documents, replace the “xx” in the document number with the largest number available in the repository to ensure that you have the most current version of the document.

Document (or Item) Name	Number	Source
[1] <i>Bluetooth MWS Coexistence 2-wire Transport Interface Specification</i>	–	www.bluetooth.com

Technical Support

Broadcom provides customer access to a wide range of information, including technical documentation, schematic diagrams, product bill of materials, PCB layout information, and software updates through its customer support portal (<https://support.broadcom.com>). For a CSP account, contact your Sales or Engineering support representative.

In addition, Broadcom provides other product support through its Downloads & Support site (<http://www.broadcom.com/support/>).

Section 1: Overview

Overview

The Broadcom® BCM4339 single-chip device provides the highest level of integration for a mobile or handheld wireless system, with integrated IEEE 802.11 a/b/g/n/ac MAC/baseband/radio, Bluetooth 4.1 + enhanced data rate (EDR), and FM receiver.

It provides a small form-factor solution with minimal external components to drive down cost for mass volumes and allows for handheld device flexibility in size, form, and function. Comprehensive power management circuitry and software ensure the system can meet the needs of highly mobile devices that require minimal power consumption and reliable operation.

The following figure shows the interconnect of all the major physical blocks in the BCM4339 and their associated external interfaces, which are described in greater detail in the following sections.

Figure 2: BCM4339 Block Diagram

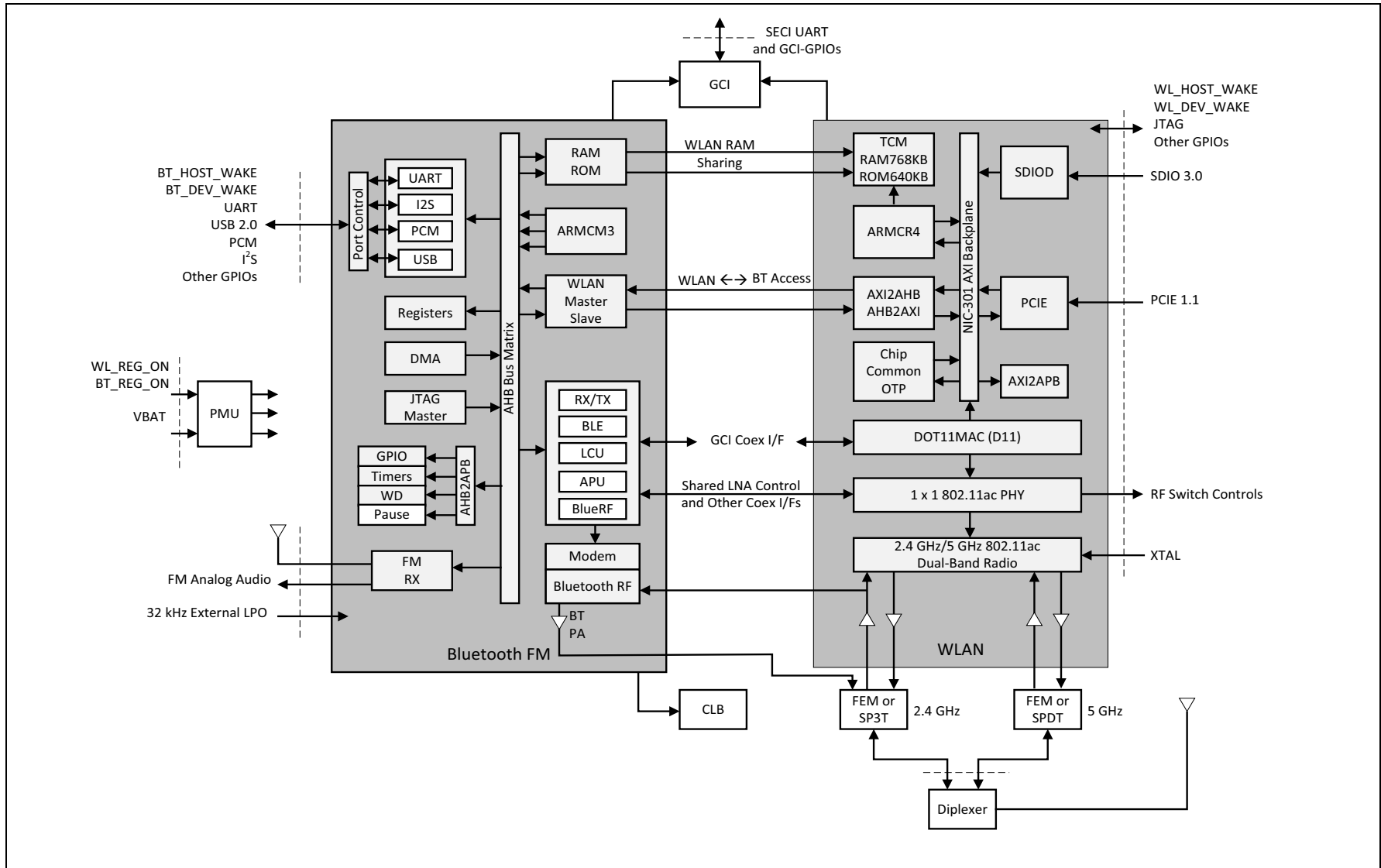

Features

The BCM4339 supports the following features:

- IEEE 802.11a/b/g/n/ac dual-band radio with virtual-simultaneous dual-band operation
- Bluetooth v4.1 + EDR with integrated Class 1 PA
- Concurrent Bluetooth, FM (RX) RDS/RBDS, and WLAN operation
- On-chip WLAN driver execution capable of supporting IEEE 802.11 functionality
- WLAN host interface options:
 - SDIO v3.0 (1-bit/4-bit)—up to 208 MHz clock rate in SDR104 mode
 - gSPI—up to 48 MHz clock rate
- BT host digital interface (which can be used concurrently with the above interfaces):
 - UART (up to 4 Mbps)
- BT supports full-speed USB version 1.1 for FCBGA package.
- ECI—enhanced coexistence support, ability to coordinate BT SCO transmissions around WLAN receptions
- I²S/PCM for FM/BT audio, HCI for FM block control
- HCI high-speed UART (H4, H4+, H5) transport support
- Wideband speech support (16 bits linear data, MSB first, left justified at 4K samples/s for transparent air coding, both through I²S and PCM interface)
- Bluetooth SmartAudio[®] technology improves voice and music quality to headsets
- Bluetooth low-power inquiry and page scan
- Bluetooth Low Energy (BLE) support
- Bluetooth Packet Loss Concealment (PLC)
- Bluetooth Wide Band Speech (WBS)
- FM advanced internal antenna support
- FM auto search/tuning functions
- FM multiple audio routing options: I²S, PCM, eSCO, and A2DP
- FM mono-stereo blend and switch, and soft mute support
- FM audio pause detection support
- Audio rate-matching algorithms
- Multiple simultaneous A2DP audio streams
- FM over Bluetooth operation and on-chip stereo headset emulation (SBC)

Standards Compliance

The BCM4339 supports the following standards:

- Bluetooth 2.1 + EDR
- Bluetooth 3.0
- Bluetooth 4.1 (Bluetooth Low Energy)
- 65 MHz to 108 MHz FM bands (US, Europe, and Japan)
- IEEE802.11ac single-stream mandatory and optional requirements for 20 MHz, 40 MHz, and 80 MHz channels
- IEEE 802.11n—Handheld Device Class (Section 11)
- IEEE 802.11a
- IEEE 802.11b
- IEEE 802.11g
- IEEE 802.11d
- IEEE 802.11h
- IEEE 802.11i
- Security:
 - WEP
 - WPA™ Personal
 - WPA2™ Personal
 - WMM
 - WMM-PS (U-APSD)
 - WMM-SA
 - AES (Hardware Accelerator)
 - TKIP (HW Accelerator)
 - CKIP (SW Support)
- Proprietary Protocols:
 - CCXv2
 - CCXv3
 - CCXv4
 - CCXv5
- IEEE 802.15.2 Coexistence Compliance—on silicon solution compliant with IEEE 3 wire requirements

The BCM4339 will support the following future drafts/standards:

- IEEE 802.11r—Fast Roaming (between APs)
- IEEE 802.11w—Secure Management Frames
- IEEE 802.11 Extensions:
 - IEEE 802.11e QoS Enhancements (as per the WMM[®] specification is already supported)
 - IEEE 802.11h 5 GHz Extensions
 - IEEE 802.11i MAC Enhancements
 - IEEE 802.11k Radio Resource Measurement

Mobile Phone Usage Model

The BCM4339 incorporates a number of unique features to simplify integration into mobile phone platforms. Its flexible PCM and UART interfaces enable it to transparently connect with existing platform circuits. In addition, the TCXO and LPO inputs allow the use of existing handset features to further minimize the size, power, and cost of the complete system.

- The PCM interface provides multiple modes of operation to support both master and slave as well as hybrid interfacing to single or multiple external codec devices.
- The UART interface supports hardware flow control with tight integration to power-control sideband signaling to support the lowest power operation.
- The crystal oscillator interface accommodates any of the typical reference frequencies used by mobile platform architectures.
- FM digital interfaces can use either I²S or PCM.
- The highly linear design of the radio transceiver ensures that the device has the lowest spurious emissions output regardless of the state of operation. It has been fully characterized in the global cellular bands.
- The transceiver design has excellent blocking and intermodulation performance in the presence of a cellular transmission (LTE, GSM[®], GPRS, CDMA, WCDMA, or iDEN).

The BCM4339 is designed to directly interface with new and existing handset platform designs.

Section 2: Power Supplies and Power Management

Power Supply Topology

One buck regulator, multiple LDO regulators, and a power management unit (PMU) are integrated into the BCM4339. All regulators are programmable via the PMU. These blocks simplify power supply design for Bluetooth, WLAN, and FM functions in embedded designs.

A single VBAT (3.0V to 5.25V DC maximum) and VIO supply (1.8V to 3.3V) can be used, with all additional voltages being provided by the regulators in the BCM4339.

Two control signals, BT_REG_ON and WL_REG_ON, are used to power up the regulators and take the respective section out of reset. The CBUCK CLDO and LNLDO power up when any of the reset signals are deasserted. All regulators are powered down only when both BT_REG_ON and WL_REG_ON are deasserted. The CLDO and LNLDO may be turned off and on based on the dynamic demands of the digital baseband.

The BCM4339 allows for an extremely low power-consumption mode by completely shutting down the CBUCK, CLDO, and LNLDO regulators. When in this state, LPLDO1 and LPLDO2 (which are low-power linear regulators that are supplied by the system VIO supply) provide the BCM4339 with all the voltages it requires, further reducing leakage currents.

PMU Features

- VBAT to 1.35V (275 mA nominal, 600 mA maximum) Core-Buck (CBUCK) switching regulator
- VBAT to 3.3V (200 mA nominal, 450 mA maximum) LDO3P3
- VBAT to 2.5V (15 mA nominal, 70 mA maximum) BTLDO2P5
- 1.35V to 1.2V (100 mA nominal, 150 mA maximum) LNLDO
- 1.35V to 1.2V (175 mA nominal, 300 mA maximum) CLDO with bypass mode for deep-sleep
- Additional internal LDOs (not externally accessible)

The following figure shows the regulators and a typical power topology.

Figure 3: Typical Power Topology for BCM4339

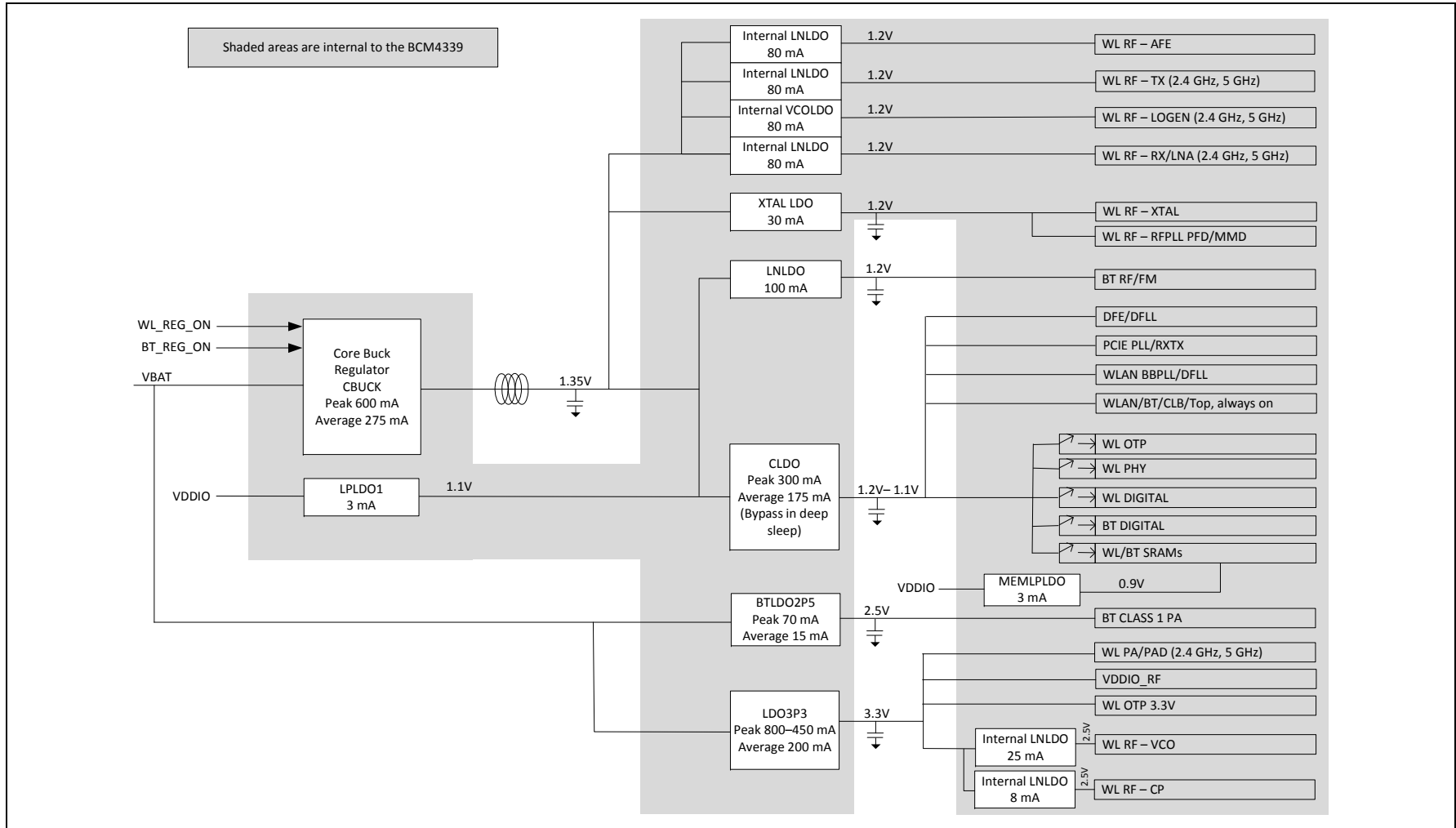

WLAN Power Management

The BCM4339 has been designed with the stringent power consumption requirements of mobile devices in mind. All areas of the chip design are optimized to minimize power consumption. Silicon processes and cell libraries were chosen to reduce leakage current and supply voltages. Additionally, the BCM4339 integrated RAM is a high Vt memory with dynamic clock control. The dominant supply current consumed by the RAM is leakage current only. Additionally, the BCM4339 includes an advanced WLAN power management unit (PMU) sequencer. The PMU sequencer provides significant power savings by putting the BCM4339 into various power management states appropriate to the current environment and activities that are being performed. The power management unit enables and disables internal regulators, switches, and other blocks based on a computation of the required resources and a table that describes the relationship between resources and the time needed to enable and disable them. Power-up sequences are fully programmable. Configurable, free-running counters (running at the 32.768 kHz LPO clock frequency) in the PMU sequencer are used to turn on and turn off individual regulators and power switches. Clock speeds are dynamically changed (or gated altogether) for the current mode. Slower clock speeds are used wherever possible.

The BCM4339 WLAN power states are described as follows:

- **Active mode**—All WLAN blocks in the BCM4339 are powered up and fully functional with active carrier sensing and frame transmission and receiving. All required regulators are enabled and put in the most efficient mode based on the load current. Clock speeds are dynamically adjusted by the PMU sequencer.
- **Doze mode**—The radio, analog domains, and most of the linear regulators are powered down. The rest of the BCM4339 remains powered up in an IDLE state. All main clocks (PLL, crystal oscillator or TCXO) are shut down to reduce active power consumption to the minimum. The 32.768 kHz LPO clock is available only for the PMU sequencer. This condition is necessary to allow the PMU sequencer to wake up the chip and transition to Active mode. In Doze mode, the primary power consumed is due to leakage current.
- **Deep-sleep mode**—Most of the chip, including both analog and digital domains, and most of the regulators are powered off. Logic states in the digital core are saved and preserved into a retention memory in the always-ON domain before the digital core is powered off. Upon a wake-up event triggered by the PMU timers, an external interrupt, or a host resume through the SDIO bus, logic states in the digital core are restored to their pre-deep-sleep settings to avoid lengthy HW reinitialization.
- **Power-down mode**—The BCM4339 is effectively powered off by shutting down all internal regulators. The chip is brought out of this mode by external logic reenabling the internal regulators.

PMU Sequencing

The PMU sequencer is responsible for minimizing system power consumption. It enables and disables various system resources based on a computation of the required resources and a table that describes the relationship between resources and the time needed to enable and disable them.

Resource requests may come from several sources: clock requests from cores, the minimum resources defined in the ResourceMin register, and the resources requested by any active resource request timers. The PMU sequencer maps clock requests into a set of resources required to produce the requested clocks.

Each resource is in one of four states (enabled, disabled, transition_on, and transition_off) and has a timer that contains 0 when the resource is enabled or disabled and a nonzero value in the transition states. The timer is loaded with the time_on or time_off value of the resource when the PMU determines that the resource must be enabled or disabled. That timer decrements on each 32.768 kHz PMU clock. When it reaches 0, the state changes from transition_off to disabled or transition_on to enabled. If the time_on value is 0, the resource can go immediately from disabled to enabled. Similarly, a time_off value of 0 indicates that the resource can go immediately from enabled to disabled. The terms enable sequence and disable sequence refer to either the immediate transition or the timer load-decrement sequence.

During each clock cycle, the PMU sequencer performs the following actions:

- Computes the required resource set based on requests and the resource dependency table.
- Decrements all timers whose values are non zero. If a timer reaches 0, the PMU clears the ResourcePending bit for the resource and inverts the ResourceState bit.
- Compares the request with the current resource status and determines which resources must be enabled or disabled.
- Initiates a disable sequence for each resource that is enabled, no longer being requested, and has no powered up dependents.
- Initiates an enable sequence for each resource that is disabled, is being requested, and has all of its dependencies enabled.

Power-Off Shutdown

The BCM4339 provides a low-power shutdown feature that allows the device to be turned off while the host, and any other devices in the system, remain operational. When the BCM4339 is not needed in the system, VDDIO_RF and VDDC are shut down while VDDIO remains powered. This allows the BCM4339 to be effectively off while keeping the I/O pins powered so that they do not draw extra current from any other devices connected to the I/O.

During a low-power shut-down state, the provided VDDIO remains applied to the BCM4339, all outputs are tristated, and most input signals are disabled. Input voltages must remain within the limits defined for normal operation. This is done to prevent current paths or create loading on any digital signals in the system, and enables the BCM4339 to be fully integrated in an embedded device and take full advantage of the lowest power-savings modes.

When the BCM4339 is powered on from this state, it is the same as a normal power-up, and the device does not retain any information about its state from before it was powered down.

Power-Up/Power-Down/Reset Circuits

The BCM4339 has two signals (see [Table 1](#)) that enable or disable the Bluetooth and WLAN circuits and the internal regulator blocks, allowing the host to control power consumption. For timing diagrams of these signals and the required power-up sequences, see [Section 21: “Power-Up Sequence and Timing,” on page 172](#).

Table 1: Power-Up/Power-Down/Reset Control Signals

Signal	Description
WL_REG_ON	This signal is used by the PMU (with BT_REG_ON) to power up the WLAN section. It is also OR-gated with the BT_REG_ON input to control the internal BCM4339 regulators. When this pin is high, the regulators are enabled and the WLAN section is out of reset. When this pin is low, the WLAN section is in reset. If BT_REG_ON and WL_REG_ON are both low, the regulators are disabled. This pin has an internal 200 kΩ pull-down resistor that is enabled by default. It can be disabled through programming.
BT_REG_ON	This signal is used by the PMU (with WL_REG_ON) to decide whether or not to power down the internal BCM4339 regulators. If BT_REG_ON and WL_REG_ON are low, the regulators will be disabled. This pin has an internal 200 kΩ pull-down resistor that is enabled by default. It can be disabled through programming.

Section 3: Frequency References

An external crystal is used for generating all radio frequencies and normal operation clocking. As an alternative, an external frequency reference may be used. In addition, a low-power oscillator (LPO) is provided for lower power mode timing.

Crystal Interface and Clock Generation

The BCM4339 can use an external crystal to provide a frequency reference. The recommended configuration for the crystal oscillator, including all external components, is shown in [Figure 4](#). Consult the reference schematics for the latest configuration and recommended components.

Figure 4: Recommended Oscillator Configuration

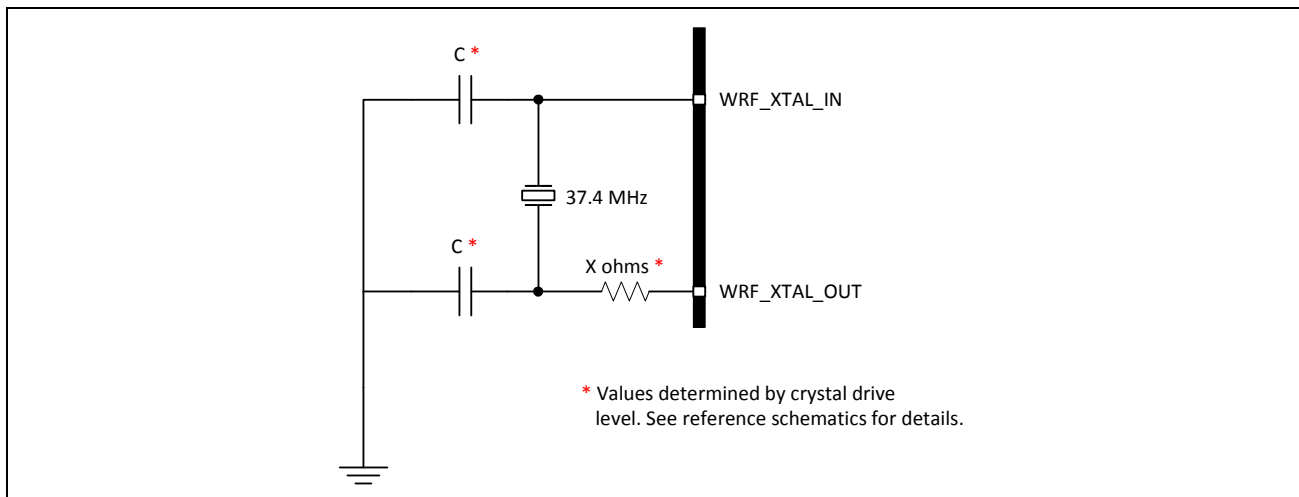

A fractional-N synthesizer in the BCM4339 generates the radio frequencies, clocks, and data/packet timing, enabling the BCM4339 to operate using a wide selection of frequency references.

For SDIO applications, the recommended default frequency reference is a 37.4 MHz crystal. The signal characteristics for the crystal interface are listed in [Table 2 on page 31](#).



Note: Although the fractional-N synthesizer can support alternative reference frequencies, frequencies other than the default require support to be added in the driver, plus additional extensive system testing. Contact Broadcom for details.

External Frequency Reference

As an alternative to a crystal, an external precision frequency reference can be used. The recommended default frequency is 37.4 MHz. This must meet the phase noise requirements listed in [Table 2](#).

If used, the external clock should be connected to the WRF_XTAL_IN pin through an external 1000 pF coupling capacitor, as shown in [Figure 5](#). The internal clock buffer connected to this pin will be turned off when the BCM4339 goes into sleep mode. When the clock buffer turns on and off, there will be a small impedance variation. Power must be supplied to the WRF_XTAL_BUCK_VDD1P5 pin.

Figure 5: Recommended Circuit to Use with an External Reference Clock

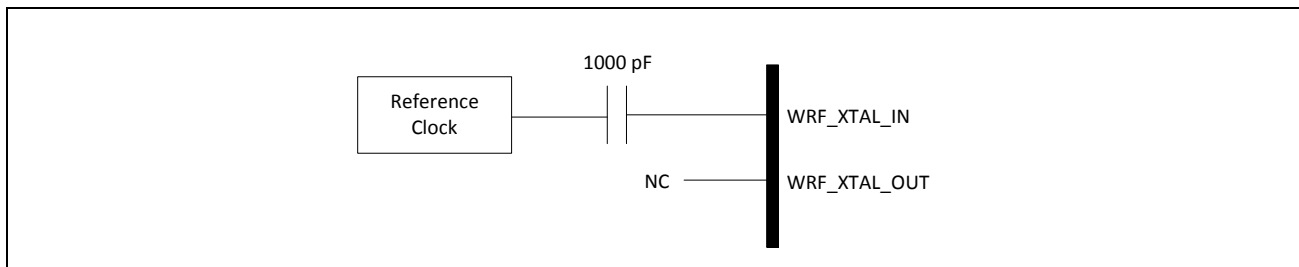

Table 2: Crystal Oscillator and External Clock—Requirements and Performance

Parameter	Conditions/Notes	Crystal ^a			External Frequency Reference ^{b c}			Units
		Min.	Typ.	Max.	Min.	Typ.	Max.	
Frequency	2.4 GHz and 5 GHz bands, IEEE 802.11ac operation	35	37.4	38.4	–	37.4	–	MHz
Frequency	5 GHz band, IEEE 802.11n operation only	19	37.4	38.4	35	37.4	38.4	MHz
Frequency	2.4 GHz band IEEE 802.11n operation, and both bands legacy 802.11a/b/g operation only	Ranges between 19 MHz and 38.4 MHz ^d						
Frequency tolerance over the lifetime of the equipment, including temperature ^e	Without trimming	–20	–	20	–20	–	20	ppm
Crystal load capacitance	–	–	12	–	–	–	–	pF
ESR	–	–	–	60	–	–	–	Ω
Drive level	External crystal must be able to tolerate this drive level.	200	–	–	–	–	–	μW
Input impedance (WRF_XTAL_IN)	Resistive	–	–	–	30k	100k	–	Ω
	Capacitive	–	–	7.5	–	–	7.5	pF
WRF_XTAL_IN input low level	DC-coupled digital signal	–	–	–	0	–	0.2	V

Table 2: Crystal Oscillator and External Clock—Requirements and Performance (Cont.)

Parameter	Conditions/Notes	Crystal ^a			External Frequency Reference ^{b c}			Units
		Min.	Typ.	Max.	Min.	Typ.	Max.	
WRF_XTAL_IN input high level	DC-coupled digital signal	–	–	–	1.0	–	1.26	V
WRF_XTAL_IN input voltage (see Figure 5)	AC-coupled analog signal	–	–	–	1000	–	1200	mV _{p-p}
Duty cycle	37.4 MHz clock	–	–	–	40	50	60	%
Phase noise ^f (IEEE 802.11b/g)	37.4 MHz clock at 10 kHz offset	–	–	–	–	–	–129	dBc/Hz
	37.4 MHz clock at 100 kHz offset	–	–	–	–	–	–136	dBc/Hz
Phase noise ^f (IEEE 802.11a)	37.4 MHz clock at 10 kHz offset	–	–	–	–	–	–137	dBc/Hz
	37.4 MHz clock at 100 kHz offset	–	–	–	–	–	–144	dBc/Hz
Phase noise ^f (IEEE 802.11n, 2.4 GHz)	37.4 MHz clock at 10 kHz offset	–	–	–	–	–	–134	dBc/Hz
	37.4 MHz clock at 100 kHz offset	–	–	–	–	–	–141	dBc/Hz
Phase noise ^f (IEEE 802.11n, 5 GHz)	37.4 MHz clock at 10 kHz offset	–	–	–	–	–	–142	dBc/Hz
	37.4 MHz clock at 100 kHz offset	–	–	–	–	–	–149	dBc/Hz
Phase noise ^f (IEEE 802.11ac, 5 GHz)	37.4 MHz clock at 10 kHz offset	–	–	–	–	–	–148	dBc/Hz
	37.4 MHz clock at 100 kHz offset	–	–	–	–	–	–155	dBc/Hz

- (Crystal) Use WRF_XTAL_IN and WRF_XTAL_OUT.
- See “External Frequency Reference” on page 31 for alternative connection methods.
- For a clock reference other than 37.4 MHz, $20 \times \log_{10}(f/37.4)$ dB should be added to the limits, where f = the reference clock frequency in MHz.
- The frequency step size is approximately 80 Hz.
- It is the responsibility of the equipment designer to select oscillator components that comply with these specifications.
- Assumes that external clock has a flat phase-noise response above 100 kHz.

Frequency Selection

Any frequency within the ranges specified for the crystal and TCXO reference may be used. These include not only the standard mobile platform reference frequencies of 19.2, 19.8, 24, 26, 33.6, 37.4, and 38.4 MHz, but also other frequencies in this range with an approximate resolution of 80 Hz. The BCM4339 must have the reference frequency set correctly in order for any of the UART or PCM interfaces to function correctly, since all bit timing is derived from the reference frequency.



Note: The fractional-N synthesizer can support many reference frequencies. However, frequencies other than the default require support to be added in the driver plus additional, extensive system testing. Contact Broadcom for details.

The reference frequency for the BCM4339 may be set in the following ways:

- Set the `xtalfreq=xxxxx` parameter in the `nvrn.txt` file (used to load the driver) to correctly match the crystal frequency.
- Autodetect any of the standard handset reference frequencies using an external LPO clock.

For applications such as handsets and portable smart communication devices, where the reference frequency is one of the standard frequencies commonly used, the BCM4339 automatically detects the reference frequency and programs itself to the correct reference frequency. In order for automatic frequency detection to work correctly, the BCM4339 must have a valid and stable 32.768 kHz LPO clock that meets the requirements listed in [Table 3 on page 34](#) and is present during power-on reset.

External 32.768 kHz Low-Power Oscillator

The BCM4339 uses a secondary low-frequency clock for low-power-mode timing. Either the internal low-precision LPO or an external 32.768 kHz precision oscillator is required. The internal LPO frequency range is approximately 33 kHz \pm 30% over process, voltage, and temperature, which is adequate for some applications. However, one trade-off caused by this wide LPO tolerance is a small current consumption increase during power save mode that is incurred by the need to wake up earlier to avoid missing beacons.

Whenever possible, the preferred approach is to use a precision external 32.768 kHz clock that meets the requirements listed in [Table 3](#).

Table 3: External 32.768 kHz Sleep Clock Specifications

Parameter	LPO Clock	Units
Nominal input frequency	32.768	kHz
Frequency accuracy	\pm 200	ppm
Duty cycle	30–70	%
Input signal amplitude	200–1800	mV, p-p
Signal type	Square-wave or sine-wave	–
Input impedance ^a	>100k	Ω
	<5	pF
Clock jitter (during initial start-up)	<10,000	ppm

a. When power is applied or switched off.

Section 4: Bluetooth + FM Subsystem Overview

The Broadcom BCM4339 is a Bluetooth 4.1 + EDR-compliant, baseband processor/2.4 GHz transceiver with an integrated FM/RDS/RBDS receiver. It features the highest level of integration and eliminates all critical external components, thus minimizing the footprint, power consumption, and system cost of a Bluetooth plus FM radio solution.

The BCM4339 is the optimal solution for any Bluetooth voice and/or data application that also requires an FM radio receiver. The Bluetooth subsystem presents a standard Host Controller Interface (HCI) via a high-speed UART and PCM for audio. The FM subsystem supports the HCI control interface, analog output, as well as I²S and PCM interfaces. The BCM4339 incorporates all Bluetooth 4.1 features including Secure Simple Pairing, Sniff Subrating, and Encryption Pause and Resume.

The BCM4339 Bluetooth radio transceiver provides enhanced radio performance to meet the most stringent mobile phone temperature applications and the tightest integration into handsets and portable devices. It is fully compatible with any of the standard TCXO frequencies and provides full radio compatibility to operate simultaneously with GPS, WLAN, and cellular radios.

The Bluetooth transmitter also features a Class 1 power amplifier with Class 2 capability.

Features

Major Bluetooth features of the BCM4339 include:

- Supports key features of upcoming Bluetooth standards
- Fully supports Bluetooth Core Specification version 4.1 + (Enhanced Data Rate) EDR features:
 - Adaptive Frequency Hopping (AFH)
 - Quality of Service (QoS)
 - Extended Synchronous Connections (eSCO)—Voice Connections
 - Fast Connect (interlaced page and inquiry scans)
 - Secure Simple Pairing (SSP)
 - Sniff Subrating (SSR)
 - Encryption Pause Resume (EPR)
 - Extended Inquiry Response (EIR)
 - Link Supervision Timeout (LST)
- UART baud rates up to 4 Mbps
- Supports Bluetooth 4.1 packet types
- Supports maximum Bluetooth data rates over HCI UART
- BT supports full-speed USB version 1.1 in the FCBGA package

- Multipoint operation with up to seven active slaves
 - Maximum of seven simultaneous active ACL links
 - Maximum of three simultaneous active SCO and eSCO connections with scatternet support
- Trigger Broadcom fast connect (TBFC)
- Narrowband and wideband packet loss concealment
- Scatternet operation with up to four active piconets with background scan and support for scatter mode
- High-speed HCI UART transport support with low-power out-of-band BT_DEV_WAKE and BT_HOST_WAKE signaling (see [“Host Controller Power Management” on page 41](#))
- Channel quality driven data rate and packet type selection
- Standard Bluetooth test modes
- Extended radio and production test mode features
- Full support for power savings modes
 - Bluetooth clock request
 - Bluetooth standard sniff
 - Deep-sleep modes and software regulator shutdown
- TCXO input and autodetection of all standard handset clock frequencies. Also supports a low-power crystal, which can be used during power save mode for better timing accuracy.

Major FM Radio Features Include:

- 65 MHz to 108 MHz FM bands supported (US, Europe, and Japan)
- FM subsystem control using the Bluetooth HCI interface
- FM subsystem operates from reference clock inputs.
- Improved audio interface capabilities with full-featured bidirectional PCM and I²S
- I²S can be master or slave.

FM Receiver-Specific Features Include:

- Excellent FM radio performance with 1 μ V sensitivity for 26 dB (S+N)/N
- Signal-dependent stereo/mono blending
- Signal-dependent soft mute
- Auto search and tuning modes
- Audio silence detection
- RSSI, IF frequency, status indicators
- RDS and RBDS demodulator and decoder with filter and buffering functions
- Automatic frequency jump

Bluetooth Radio

The BCM4339 has an integrated radio transceiver that has been optimized for use in 2.4 GHz Bluetooth wireless systems. It has been designed to provide low-power, low-cost, robust communications for applications operating in the globally available 2.4 GHz unlicensed ISM band. It is fully compliant with the Bluetooth Radio Specification and EDR specification and meets or exceeds the requirements to provide the highest communication link quality.

Transmit

The BCM4339 features a fully integrated zero-IF transmitter. The baseband transmit data is GFSK-modulated in the modem block and upconverted to the 2.4 GHz ISM band in the transmitter path. The transmitter path performs signal filtering, I/Q upconversion, output power amplification, and RF filtering. The transmitter path also incorporates $\pi/4$ -DQPSK and 8-DPSK modulations for 2 Mbps and 3 Mbps EDR support, respectively. The transmitter section is compatible to the Bluetooth Low Energy specification. The transmitter PA bias can also be adjusted to provide Bluetooth Class 1 or Class 2 operation.

Digital Modulator

The digital modulator performs the data modulation and filtering required for the GFSK, $\pi/4$ -DQPSK, and 8-DPSK signal. The fully digital modulator minimizes any frequency drift or anomalies in the modulation characteristics of the transmitted signal and is much more stable than direct VCO modulation schemes.

Digital Demodulator and Bit Synchronizer

The digital demodulator and bit synchronizer take the low-IF received signal and perform an optimal frequency tracking and bit-synchronization algorithm.

Power Amplifier

The fully integrated PA supports Class 1 or Class 2 output using a highly linearized, temperature-compensated design. This provides greater flexibility in front-end matching and filtering. Due to the linear nature of the PA combined with some integrated filtering, external filtering is required to meet the Bluetooth and regulatory harmonic and spurious requirements. For integrated handset applications in which Bluetooth is integrated next to the cellular radio, external filtering can be applied to achieve near-thermal-noise levels for spurious and radiated noise emissions. The transmitter features a sophisticated on-chip transmit signal strength indicator (TSSI) block to keep the absolute output power variation within a tight range across process, voltage, and temperature.

Receiver

The receiver path uses a low-IF scheme to downconvert the received signal for demodulation in the digital demodulator and bit synchronizer. The receiver path provides a high degree of linearity, an extended dynamic range, and high-order on-chip channel filtering to ensure reliable operation in the noisy 2.4 GHz ISM band. The front-end topology, with built-in out-of-band attenuation, enables the BCM4339 to be used in most applications with minimal off-chip filtering. For integrated handset operation, in which the Bluetooth function is integrated close to the cellular transmitter, external filtering is required to eliminate the desensitization of the receiver by the cellular transmit signal.

Digital Demodulator and Bit Synchronizer

The digital demodulator and bit synchronizer take the low-IF received signal and perform an optimal frequency tracking and bit synchronization algorithm.

Receiver Signal Strength Indicator

The radio portion of the BCM4339 provides a Receiver Signal Strength Indicator (RSSI) signal to the baseband, so that the controller can determine whether the transmitter should increase or decrease its output power.

Local Oscillator Generation

Local Oscillator (LO) generation provides fast frequency hopping (1600 hops/second) across the 79 maximum available channels. The LO generation subblock employs an architecture for high immunity to LO pulling during PA operation. The BCM4339 uses an internal RF and IF loop filter.

Calibration

The BCM4339 radio transceiver features an automated calibration scheme that is fully self contained in the radio. No user interaction is required during normal operation or during manufacturing to provide the optimal performance. Calibration optimizes the performance of all the major blocks within the radio to within 2% of optimal conditions, including gain and phase characteristics of filters, matching between key components, and key gain blocks. This takes into account process variation and temperature variation. Calibration occurs during normal operation during the settling time of the hops and calibrates for temperature variations as the device cools and heats during normal operation in its environment.

Section 5: Bluetooth Baseband Core

The Bluetooth Baseband Core (BBC) implements all of the time critical functions required for high-performance Bluetooth operation. The BBC manages the buffering, segmentation, and routing of data for all connections. It also buffers data that passes through it, handles data flow control, schedules SCO/ACL TX/RX transactions, monitors Bluetooth slot usage, optimally segments and packages data into baseband packets, manages connection status indicators, and composes and decodes HCI packets. In addition to these functions, it independently handles HCI event types, and HCI command types.

The following transmit and receive functions are also implemented in the BBC hardware to increase reliability and security of the TX/RX data:

- Symbol timing recovery, data deframing, forward error correction (FEC), header error control (HEC), cyclic redundancy check (CRC), data decryption, and data dewatering in the receiver.
- Data framing, FEC generation, HEC generation, CRC generation, key generation, data encryption, and data whitening in the transmitter.

Bluetooth 4.1 Features

The BBC supports all Bluetooth 4.1 features, with the following benefits:

- Dual-mode bluetooth Low Energy (BT and BLE operation)
- Extended Inquiry Response (EIR): Shortens the time to retrieve the device name, specific profile, and operating mode.
- Encryption Pause Resume (EPR): Enables the use of Bluetooth technology in a much more secure environment.
- Sniff Subrating (SSR): Optimizes power consumption for low duty cycle asymmetric data flow, which subsequently extends battery life.
- Secure Simple Pairing (SSP): Reduces the number of steps for connecting two devices, with minimal or no user interaction required.
- Link Supervision Time Out (LSTO): Additional commands added to HCI and Link Management Protocol (LMP) for improved link time-out supervision.
- QoS enhancements: Changes to data traffic control, which results in better link performance. Audio, human interface device (HID), bulk traffic, SCO, and enhanced SCO (eSCO) are improved with the erroneous data (ED) and packet boundary flag (PBF) enhancements.

Bluetooth Low Energy

The BCM4339 supports the Bluetooth Low Energy operating mode.

Link Control Layer

The link control layer is part of the Bluetooth link control functions that are implemented in dedicated logic in the link control unit (LCU). This layer consists of the command controller that takes commands from the software, and other controllers that are activated or configured by the command controller to perform the link control tasks. Each task performs a different state in the Bluetooth Link Controller.

- Major states:
 - Standby
 - Connection
- Substates:
 - Page
 - Page Scan
 - Inquiry
 - Inquiry Scan
 - Sniff

Test Mode Support

The BCM4339 fully supports Bluetooth Test mode as described in Part I:1 of the *Specification of the Bluetooth System Version 3.0*. This includes the transmitter tests, normal and delayed loopback tests, and reduced hopping sequence.

In addition to the standard Bluetooth Test Mode, the BCM4339 also supports enhanced testing features to simplify RF debugging, qualification, and type-approval testing. These features include:

- Fixed-frequency carrier-wave (unmodulated) transmission
 - Simplifies some type-approval measurements (Japan)
 - Aids in transmitter performance analysis
- Fixed-frequency constant-receiver mode
 - Receiver output directed to I/O pin
 - Allows for direct BER measurements using standard RF test equipment
 - Facilitates spurious emissions testing for receive mode
- Fixed frequency constant transmission
 - Eight-bit fixed pattern or PRBS-9
 - Enables modulated signal measurements with standard RF test equipment

Bluetooth Power Management Unit

The Bluetooth Power Management Unit (PMU) provides power management features that can be invoked by either software through power management registers or packet handling in the baseband core. The power management functions provided by the BCM4339 are:

- [RF Power Management](#)
- [Host Controller Power Management](#)
- [“BBC Power Management” on page 43](#)
- [“FM Power Management” on page 43](#)

RF Power Management

The BBC generates power-down control signals to the 2.4 GHz transceiver for the transmit path, receive path, PLL, and power amplifier. The transceiver then processes the power-down functions accordingly.

Host Controller Power Management

When running in UART mode, the BCM4339 may be configured so that dedicated signals are used for power management handshaking between the BCM4339 and the host. The basic power saving functions supported by those handshaking signals include the standard Bluetooth defined power savings modes and standby modes of operation.

[Table 4](#) describes the power-control handshake signals used with the UART interface.

Table 4: Power Control Pin Description

Signal	Mapped to Pin	Type	Description
BT_DEV_WAKE	BT_GPIO_0	I	<p>Bluetooth device wake-up: Signal from the host to the BCM4339 indicating that the host requires attention.</p> <ul style="list-style-type: none"> • Asserted: The Bluetooth device must wake-up or remain awake. • Deasserted: The Bluetooth device may sleep when sleep criteria are met. <p>The polarity of this signal is software configurable and can be asserted high or low.</p>
BT_HOST_WAKE	BT_GPIO_1	O	<p>Host wake up. Signal from the BCM4339 to the host indicating that the BCM4339 requires attention.</p> <ul style="list-style-type: none"> • Asserted: host device must wake-up or remain awake. • Deasserted: host device may sleep when sleep criteria are met. <p>The polarity of this signal is software configurable and can be asserted high or low.</p>

Table 4: Power Control Pin Description (Cont.)

Signal	Mapped to Pin	Type	Description
CLK_REQ	BT_CLK_REQ_OUT WL_CLK_REQ_OUT	O	The BCM4339 asserts CLK_REQ when either the Bluetooth or WLAN block wants the host to turn on the reference clock. The CLK_REQ polarity is active-high. Add an external 100 kΩ pull-down resistor to ensure the signal is deasserted when the BCM4339 powers up or resets when VDDIO is present.

Note: Pad function Control Register is set to 0 for these pins. See “DC Characteristics” on page 122 for more details.

Figure 6: Startup Signaling Sequence

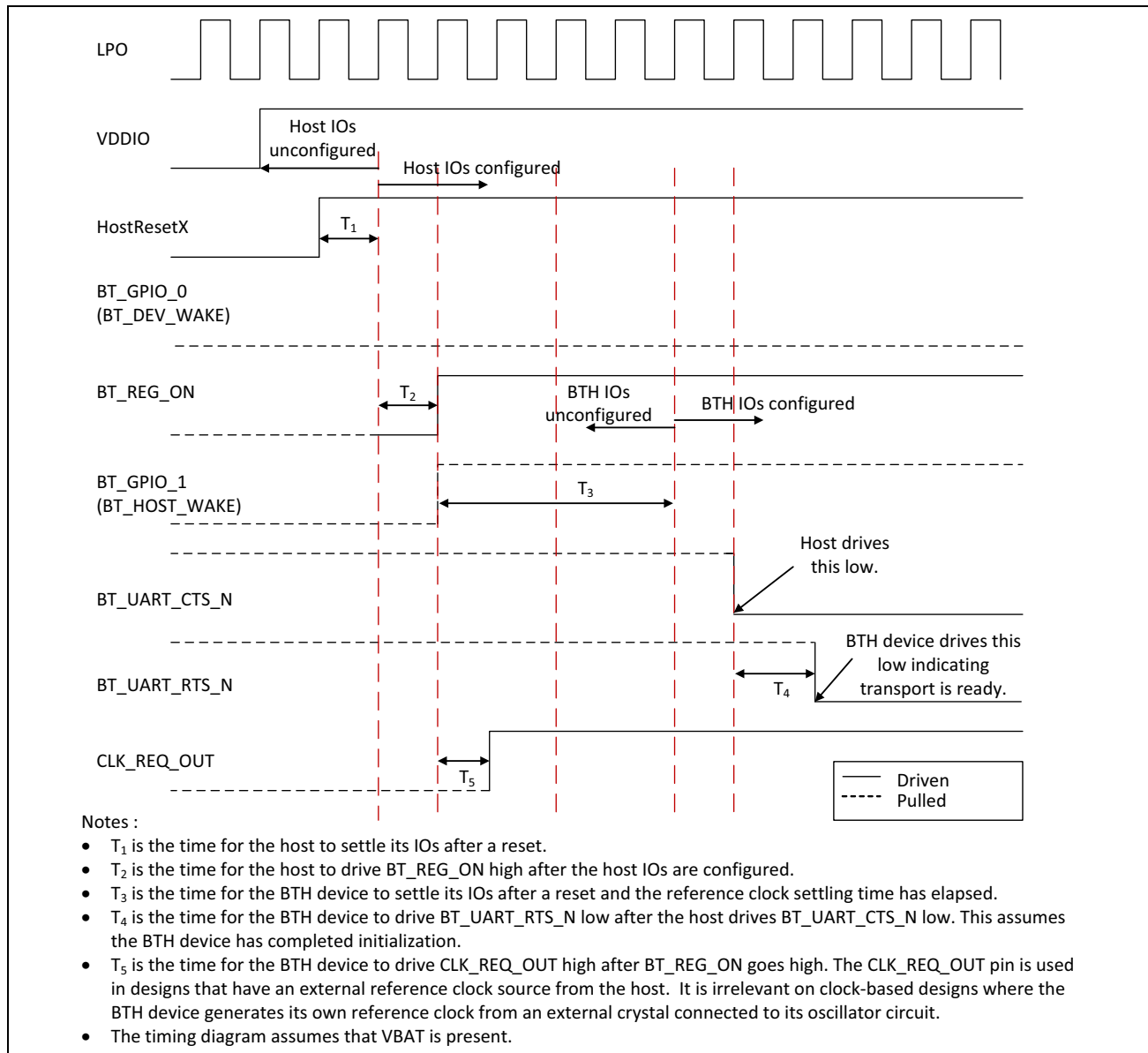

BBC Power Management

The following are low-power operations for the BBC:

- Physical layer packet-handling turns the RF on and off dynamically within transmit/receive packets.
- Bluetooth-specified low-power connection modes: sniff, hold, and park. While in these modes, the BCM4339 runs on the low-power oscillator and wakes up after a predefined time period.
- A low-power shutdown feature allows the device to be turned off while the host and any other devices in the system remain operational. When the BCM4339 is not needed in the system, the RF and core supplies are shut down while the I/O remains powered. This allows the BCM4339 to effectively be off while keeping the I/O pins powered so they do not draw extra current from any other devices connected to the I/O.

During the low-power shut-down state, provided VDDIO remains applied to the BCM4339, all outputs are tristated, and most input signals are disabled. Input voltages must remain within the limits defined for normal operation. This is done to prevent current paths or create loading on any digital signals in the system and enables the BCM4339 to be fully integrated in an embedded device to take full advantage of the lowest power-saving modes.

Two BCM4339 input signals are designed to be high-impedance inputs that do not load the driving signal even if the chip does not have VDDIO power supplied to it: the frequency reference input (WRF_TCXO_IN) and the 32.768 kHz input (LPO). When the BCM4339 is powered on from this state, it is the same as a normal power-up, and the device does not contain any information about its state from the time before it was powered down.

FM Power Management

The BCM4339 FM subsystem can operate independently of, or in tandem with, the Bluetooth RF and BBC subsystems. The FM subsystem power management scheme operates in conjunction with the Bluetooth RF and BBC subsystems. The FM block does not have a low power state, it is either on or off.

Wideband Speech

The BCM4339 provides support for wideband speech (WBS) using on-chip SmartAudio technology. The BCM4339 can perform subband-codec (SBC), as well as mSBC, encoding and decoding of linear 16 bits at 16 kHz (256 kbps rate) transferred over the PCM bus.

Packet Loss Concealment

Packet Loss Concealment (PLC) improves apparent audio quality for systems with marginal link performance. Bluetooth messages are sent in packets. When a packet is lost, it creates a gap in the received audio bitstream. Packet loss can be mitigated in several ways:

- Fill in zeros.
- Ramp down the output audio signal toward zero (this is the method used in current Bluetooth headsets).
- Repeat the last frame (or packet) of the received bitstream and decode it as usual (frame repeat).

These techniques cause distortion and popping in the audio stream. The BCM4339 uses a proprietary waveform extension algorithm to provide dramatic improvement in the audio quality. [Figure 7](#) and [Figure 8](#) show audio waveforms with and without Packet Loss Concealment. Broadcom PLC and bit-error correction (BEC) algorithms also support wideband speech.

Figure 7: CVSD Decoder Output Waveform Without PLC

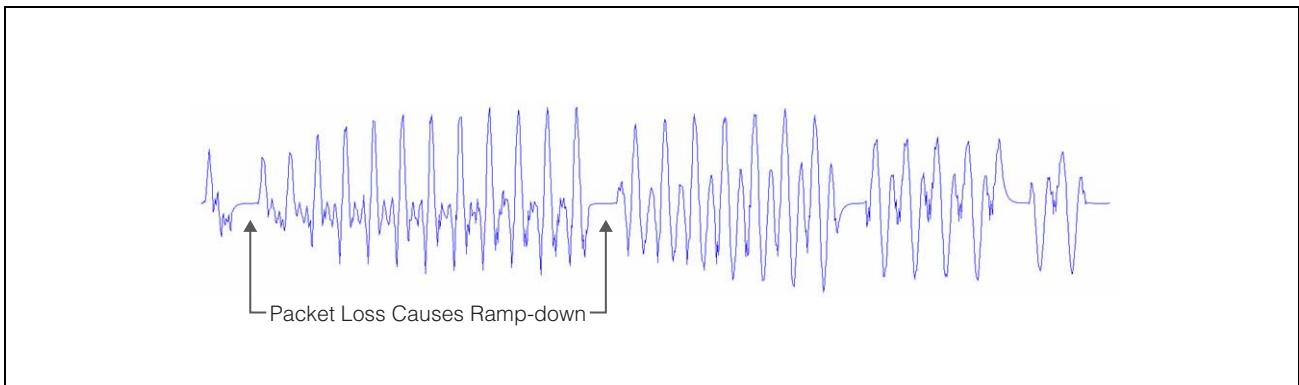

Figure 8: CVSD Decoder Output Waveform After Applying PLC



Audio Rate-Matching Algorithms

The BCM4339 has an enhanced rate-matching algorithm that uses interpolation algorithms to reduce audio stream jitter that may be present when the rate of audio data coming from the host is not the same as the Bluetooth or FM audio data rates.

Codec Encoding

The BCM4339 can support SBC and mSBC encoding and decoding for wideband speech.

Multiple Simultaneous A2DP Audio Streams

The BCM4339 has the ability to take a single audio stream and output it to multiple Bluetooth devices simultaneously. This allows a user to share his or her music (or any audio stream) with a friend.

FM Over Bluetooth

FM over Bluetooth enables the BCM4339 to stream data from FM over Bluetooth without requiring the host to be awake. This can significantly extend battery life for usage cases where someone is listening to FM radio on a Bluetooth headset.

Burst Buffer Operation

The BCM4339 has a data buffer that can buffer data being sent over the HCI and audio transports, then send the data at an increased rate. This mode of operation allows the host to sleep for the maximum amount of time, dramatically reducing system current consumption.

Adaptive Frequency Hopping

The BCM4339 gathers link quality statistics on a channel by channel basis to facilitate channel assessment and channel map selection. The link quality is determined using both RF and baseband signal processing to provide a more accurate frequency-hop map.

Advanced Bluetooth/WLAN Coexistence

The BCM4339 includes advanced coexistence technologies that are only possible with a Bluetooth/WLAN integrated die solution. These coexistence technologies are targeted at small form-factor platforms, such as cell phones and media players, including applications such as VoWLAN + SCO and Video-over-WLAN + High Fidelity BT Stereo.

Support is provided for platforms that share a single antenna between Bluetooth and WLAN. The BCM4339 radio architecture allows for lossless simultaneous Bluetooth and WLAN reception for shared antenna applications. This is possible only via an integrated solution (shared LNA and joint AGC algorithm). It has superior performance versus implementations that need to arbitrate between Bluetooth and WLAN reception.

The BCM4339 integrated solution enables MAC-layer signaling (firmware) and a greater degree of sharing via an enhanced coexistence interface. Information is exchanged between the Bluetooth and WLAN cores without host processor involvement.

The BCM4339 also supports Transmit Power Control (TPC) on the STA together with standard Bluetooth TPC to limit mutual interference and receiver desensitization. Preemption mechanisms are utilized to prevent AP transmissions from colliding with Bluetooth frames. Improved channel classification techniques have been implemented in Bluetooth for faster and more accurate detection and elimination of interferers (including non-WLAN 2.4 GHz interference).

The Bluetooth AFH classification is also enhanced by the WLAN core's channel information.

Fast Connection (Interlaced Page and Inquiry Scans)

The BCM4339 supports page scan and inquiry scan modes that significantly reduce the average inquiry response and connection times. These scanning modes are compatible with the Bluetooth version 2.1 page and inquiry procedures.

Section 6: Microprocessor and Memory Unit for Bluetooth

The Bluetooth microprocessor core is based on the ARM® Cortex-M3™ 32-bit RISC processor with embedded ICE-RT debug and JTAG interface units. It runs software from the link control (LC) layer, up to the host controller interface (HCI).

The ARM core is paired with a memory unit that contains 608 KB of ROM memory for program storage and boot ROM, 192 KB of RAM for data scratch-pad and patch RAM code. The internal ROM allows for flexibility during power-on reset to enable the same device to be used in various configurations. At power-up, the lower-layer protocol stack is executed from the internal ROM memory.

External patches may be applied to the ROM-based firmware to provide flexibility for bug fixes or feature additions. These patches may be downloaded from the host to the BCM4339 through the UART transports. The mechanism for downloading via UART is identical to the proven interface of the BCM4329 and BCM4330 devices.

RAM, ROM, and Patch Memory

The BCM4339 Bluetooth core has 192 KB of internal RAM which is mapped between general purpose scratch-pad memory and patch memory and 608 KB of ROM used for the lower-layer protocol stack, test mode software, and boot ROM. The patch memory capability enables feature additions and bug fixes to the ROM memory.

Reset

The BCM4339 has an integrated power-on reset circuit that resets all circuits to a known power-on state. The BT power-on reset (POR) circuit is out of reset after BT_REG_ON goes high. If BT_REG_ON is low, then the POR circuit is held in reset.

Section 7: Bluetooth Peripheral Transport Unit

SPI Interface

The BCM4339 supports a slave SPI HCI transport with an input clock range of up to 16 MHz. Higher clock rates are possible. The physical interface between the SPI master and the BCM4339 contains the four SPI signals (SPI_CSB, SPI_CLK, SPI_SI, and SPI_SO) and one interrupt signal (SPI_INT). The SPI signals are muxed onto the UART signals, see [Table 5](#). The BCM4339 can be configured to accept active-low or active-high polarity on the SPI_CSB chip-select signal. It can also be configured to drive an active-low or active-high SPI_INT interrupt signal. Bit ordering on the SPI_SI and SPI_SO data lines can be configured as either little-endian or big-endian.

Additionally, proprietary sleep mode and half-duplex handshaking is implemented between the SPI master and the BCM4339. The SPI_INT is required to negotiate the start of a transaction. The SPI interface does not require flow control in the middle of a payload. The FIFO is large enough to handle the largest packet size. Only the SPI master can stop the flow of bytes on the data lines, since it controls SPI_CSB and SPI_CLK. Flow control should be implemented in the higher layer protocols.

Table 5: SPI to UART Signal Mapping

SPI Signals	UART Signals
SPI_CLK	UART_CTS_N
SPI_CSB	UART_RTS_N
SPI_MISO	UART_RXD
SPI_MOSI	UART_TXD
SPI_INT	BT_HOST_WAKE

SPI/UART Transport Detection

The BT_HOST_WAKE (BT_GPIO1) pin is also used for BT transport detection. Transport detection occurs during the power-up sequence. Either UART or SPI transport operation is selected based on the following pin state:

- If the BT_HOST_WAKE (BT_GPIO1) pin is pulled low by an external pull-down during power-up, the SPI transport interface is selected.
- If the BT_HOST_WAKE (BT_GPIO1) pin is not pulled low externally during power-up, then the default internal pull-up is detected as a high and the UART transport interface is selected.

PCM Interface

The BCM4339 supports two independent PCM interfaces that share pins with the I²S interfaces. The PCM Interface on the BCM4339 can connect to linear PCM codec devices in master or slave mode. In master mode, the BCM4339 generates the PCM_CLK and PCM_SYNC signals, and in slave mode, these signals are provided by another master on the PCM interface and are inputs to the BCM4339.

The configuration of the PCM interface may be adjusted by the host through the use of vendor-specific HCI commands.

Slot Mapping

The BCM4339 supports up to three simultaneous full-duplex SCO or eSCO channels through the PCM interface. These three channels are time-multiplexed onto the single PCM interface by using a time-slotting scheme where the 8 kHz or 16 kHz audio sample interval is divided into as many as 16 slots. The number of slots is dependent on the selected interface rate of 128 kHz, 512 kHz, or 1024 kHz. The corresponding number of slots for these interface rate is 1, 2, 4, 8, and 16, respectively. Transmit and receive PCM data from an SCO channel is always mapped to the same slot. The PCM data output driver tri-states its output on unused slots to allow other devices to share the same PCM interface signals. The data output driver tristates its output after the falling edge of the PCM clock during the last bit of the slot.

Frame Synchronization

The BCM4339 supports both short- and long-frame synchronization in both master and slave modes. In short-frame synchronization mode, the frame synchronization signal is an active-high pulse at the audio frame rate that is a single-bit period in width and is synchronized to the rising edge of the bit clock. The PCM slave looks for a high on the falling edge of the bit clock and expects the first bit of the first slot to start at the next rising edge of the clock. In long-frame synchronization mode, the frame synchronization signal is again an active-high pulse at the audio frame rate; however, the duration is three bit periods and the pulse starts coincident with the first bit of the first slot.

Data Formatting

The BCM4339 may be configured to generate and accept several different data formats. For conventional narrowband speech mode, the BCM4339 uses 13 of the 16 bits in each PCM frame. The location and order of these 13 bits can be configured to support various data formats on the PCM interface. The remaining three bits are ignored on the input and may be filled with 0s, 1s, a sign bit, or a programmed value on the output. The default format is 13-bit 2's complement data, left justified, and clocked MSB first.

Wideband Speech Support

When the host encodes Wideband Speech (WBS) packets in transparent mode, the encoded packets are transferred over the PCM bus for an eSCO voice connection. In this mode, the PCM bus is typically configured in master mode for a 4 kHz sync rate with 16-bit samples, resulting in a 64 Kbps bit rate. The BCM4339 also supports slave transparent mode using a proprietary rate-matching scheme. In SBC-code mode, linear 16-bit data at 16 kHz (256 Kbps rate) is transferred over the PCM bus.

Multiplexed Bluetooth and FM Over PCM

In this mode of operation, the BCM4339 multiplexes both FM and Bluetooth audio PCM channels over the same interface, reducing the number of required I/Os. This mode of operation is initiated through an HCI command from the host. The format of the data stream consists of three channels: a Bluetooth channel followed by two FM channels (audio left and right). In this mode of operation, the bus data rate only supports 48 kHz operation per channel with 16 bits sent for each channel.

This is done to allow the low data rate Bluetooth data to coexist in the same interface as the higher speed I²S data. To accomplish this, the Bluetooth data is repeated six times for 8 kHz data and three times for 16 kHz data. An initial sync pulse on the PCM_SYNC line is used to indicate the beginning of the frame.

To support multiple Bluetooth audio streams within the Bluetooth channel, both 16 kHz and 8 kHz streams can be multiplexed. This mode of operation is only supported when the Bluetooth host is the master. Figure 9 shows the operation of the multiplexed transport with three simultaneous SCO connections. To accommodate additional SCO channels, the transport clock speed is increased. To change between modes of operation, the transport must be halted and restarted in the new configuration.

Figure 9: Functional Multiplex Data Diagram

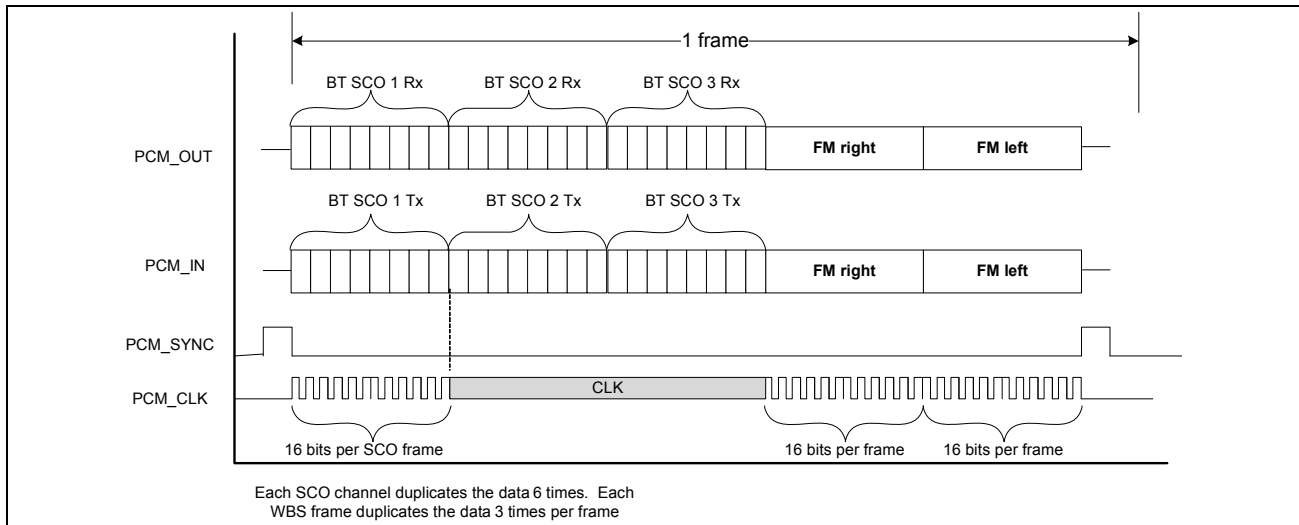

Burst PCM Mode

In this mode of operation, the PCM bus runs at a significantly higher rate of operation to allow the host to duty cycle its operation and save current. In this mode of operation, the PCM bus can operate at a rate of up to 24 MHz. This mode of operation is initiated with an HCI command from the host.

PCM Interface Timing

Short Frame Sync, Master Mode

Figure 10: PCM Timing Diagram (Short Frame Sync, Master Mode)

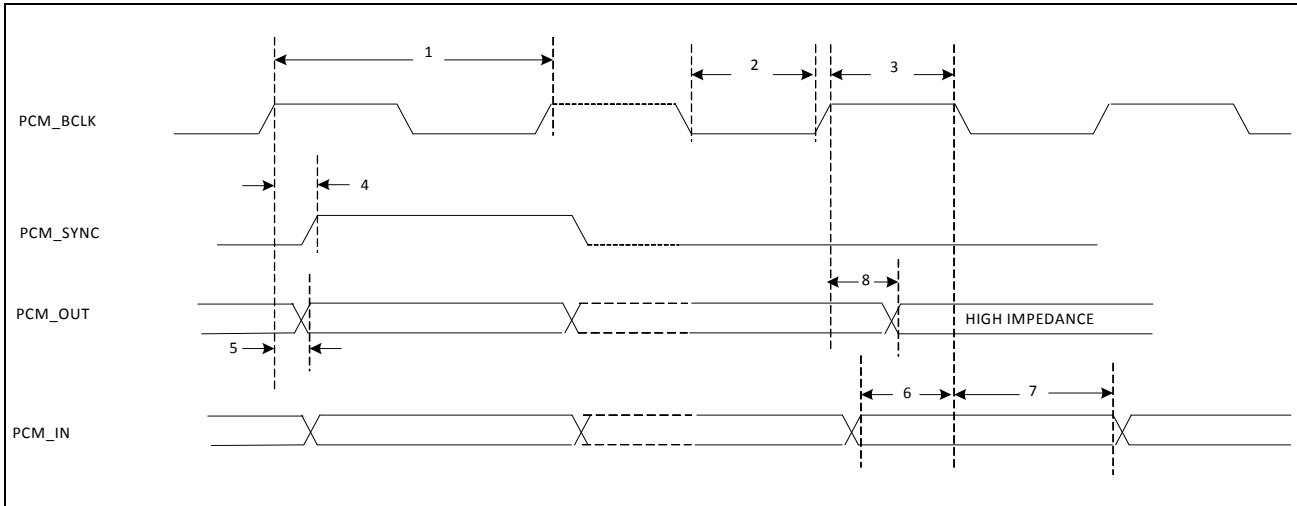

Table 6: PCM Interface Timing Specifications (Short Frame Sync, Master Mode)

Ref No.	Characteristics	Minimum	Typical	Maximum	Unit
1	PCM bit clock frequency	–	–	12	MHz
2	PCM bit clock LOW	41	–	–	ns
3	PCM bit clock HIGH	41	–	–	ns
4	PCM_SYNC delay	0	–	25	ns
5	PCM_OUT delay	0	–	25	ns
6	PCM_IN setup	8	–	–	ns
7	PCM_IN hold	8	–	–	ns
8	Delay from rising edge of PCM_BCLK during last bit period to PCM_OUT becoming high impedance	0	–	25	ns

Short Frame Sync, Slave Mode

Figure 11: PCM Timing Diagram (Short Frame Sync, Slave Mode)

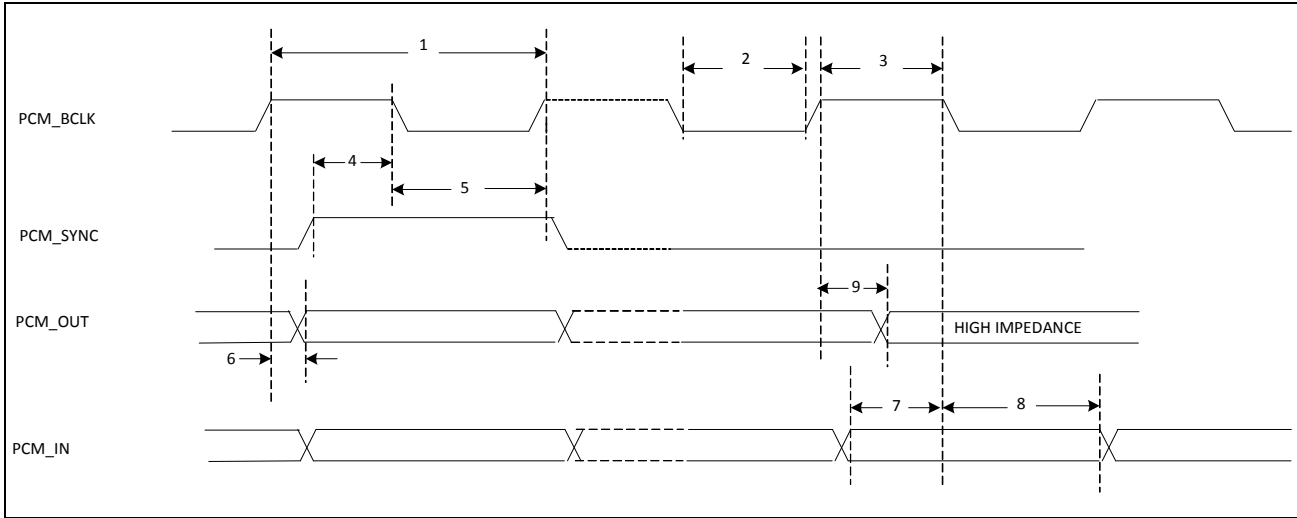

Table 7: PCM Interface Timing Specifications (Short Frame Sync, Slave Mode)

Ref No.	Characteristics	Minimum	Typical	Maximum	Unit
1	PCM bit clock frequency	–	–	12	MHz
2	PCM bit clock LOW	41	–	–	ns
3	PCM bit clock HIGH	41	–	–	ns
4	PCM_SYNC setup	8	–	–	ns
5	PCM_SYNC hold	8	–	–	ns
6	PCM_OUT delay	0	–	25	ns
7	PCM_IN setup	8	–	–	ns
8	PCM_IN hold	8	–	–	ns
9	Delay from rising edge of PCM_BCLK during last bit period to PCM_OUT becoming high impedance	0	–	25	ns

Long Frame Sync, Master Mode

Figure 12: PCM Timing Diagram (Long Frame Sync, Master Mode)

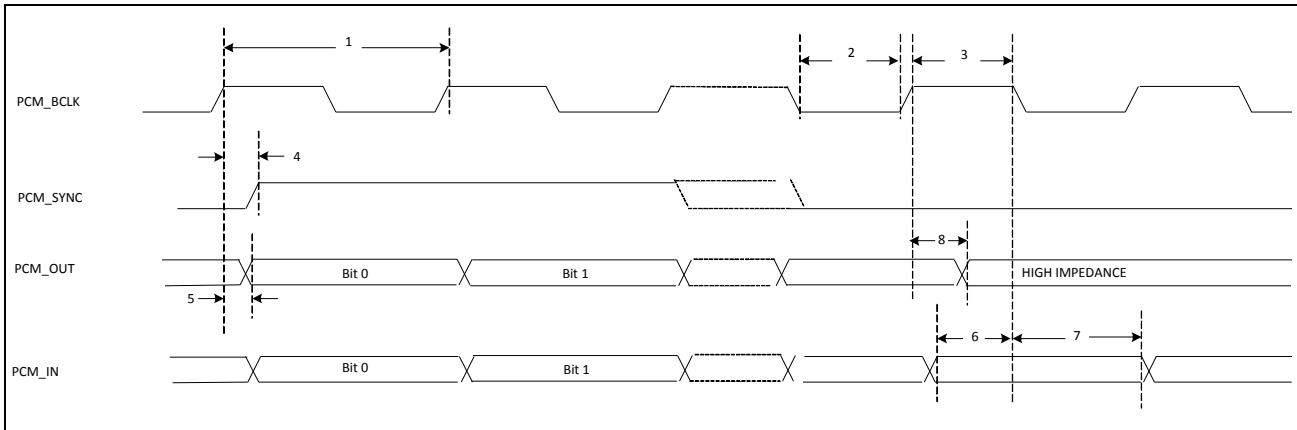

Table 8: PCM Interface Timing Specifications (Long Frame Sync, Master Mode)

Ref No.	Characteristics	Minimum	Typical	Maximum	Unit
1	PCM bit clock frequency	–	–	12	MHz
2	PCM bit clock LOW	41	–	–	ns
3	PCM bit clock HIGH	41	–	–	ns
4	PCM_SYNC delay	0	–	25	ns
5	PCM_OUT delay	0	–	25	ns
6	PCM_IN setup	8	–	–	ns
7	PCM_IN hold	8	–	–	ns
8	Delay from rising edge of PCM_BCLK during last bit period to PCM_OUT becoming high impedance	0	–	25	ns

Long Frame Sync, Slave Mode

Figure 13: PCM Timing Diagram (Long Frame Sync, Slave Mode)

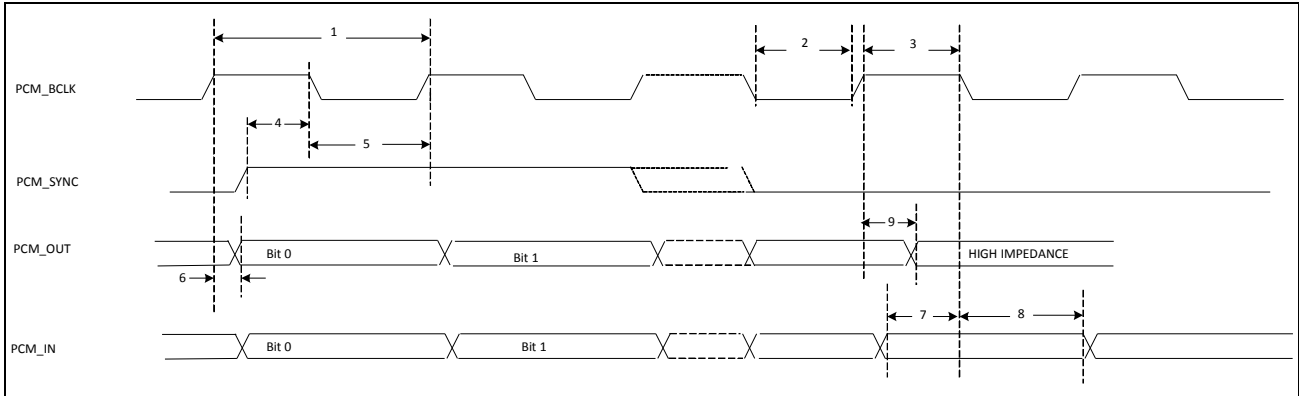

Table 9: PCM Interface Timing Specifications (Long Frame Sync, Slave Mode)

Ref No.	Characteristics	Minimum	Typical	Maximum	Unit
1	PCM bit clock frequency	–	–	12	MHz
2	PCM bit clock LOW	41	–	–	ns
3	PCM bit clock HIGH	41	–	–	ns
4	PCM_SYNC setup	8	–	–	ns
5	PCM_SYNC hold	8	–	–	ns
6	PCM_OUT delay	0	–	25	ns
7	PCM_IN setup	8	–	–	ns
8	PCM_IN hold	8	–	–	ns
9	Delay from rising edge of PCM_BCLK during last bit period to PCM_OUT becoming high impedance	0	–	25	ns

Short Frame Sync, Burst Mode

Figure 14: PCM Burst Mode Timing (Receive Only, Short Frame Sync)

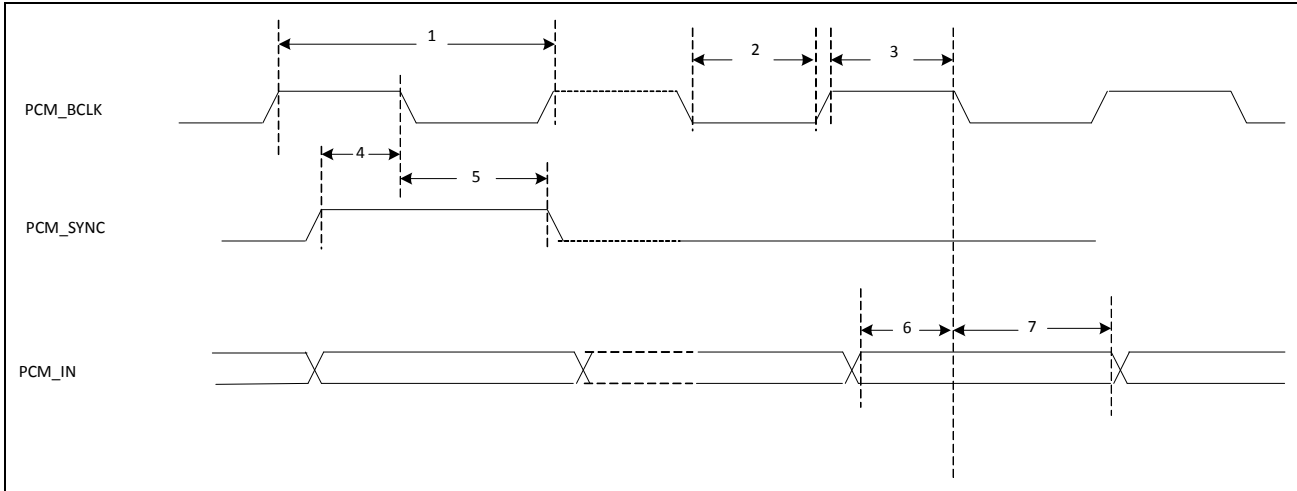

Table 10: PCM Burst Mode (Receive Only, Short Frame Sync)

Ref No.	Characteristics	Minimum	Typical	Maximum	Unit
1	PCM bit clock frequency	–	–	24	MHz
2	PCM bit clock LOW	20.8	–	–	ns
3	PCM bit clock HIGH	20.8	–	–	ns
4	PCM_SYNC setup	8	–	–	ns
5	PCM_SYNC hold	8	–	–	ns
6	PCM_IN setup	8	–	–	ns
7	PCM_IN hold	8	–	–	ns

Long Frame Sync, Burst Mode

Figure 15: PCM Burst Mode Timing (Receive Only, Long Frame Sync)

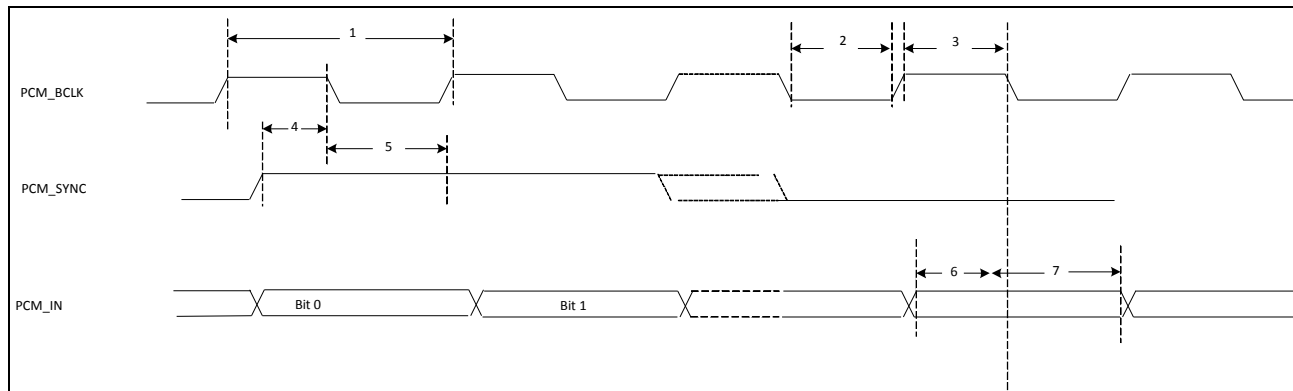

Table 11: PCM Burst Mode (Receive Only, Long Frame Sync)

Ref No.	Characteristics	Minimum	Typical	Maximum	Unit
1	PCM bit clock frequency	–	–	24	MHz
2	PCM bit clock LOW	20.8	–	–	ns
3	PCM bit clock HIGH	20.8	–	–	ns
4	PCM_SYNC setup	8	–	–	ns
5	PCM_SYNC hold	8	–	–	ns
6	PCM_IN setup	8	–	–	ns
7	PCM_IN hold	8	–	–	ns

USB Interface

Features

The following USB interface features are supported:

- USB Protocol, Revision 2.0, full-speed (12 Mbps) compliant including the hub
- Optional hub compound device with up to three device cores internal to device
- Bus or self-power, dynamic configuration for the hub
- Global and selective suspend and resume with remote wakeup
- Bluetooth HCI
- HID, DFU, UHE (proprietary method to emulate an HID device at system bootup)
- Integrated detach resistor

Operation

The BCM4339 can be configured to boot up as either a single USB peripheral or a USB hub with several USB peripherals attached. As a single peripheral, the host detects a single USB Bluetooth device. In hub mode, the host detects a hub with one to three of the ports already connected to USB devices (see [Figure 16](#)).

Figure 16: USB Compounded Device Configuration

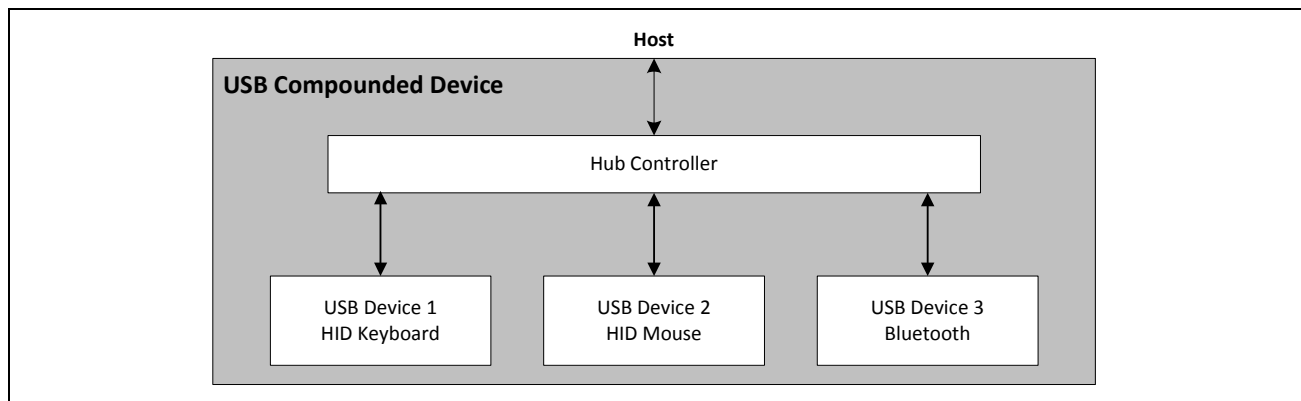

Depending on the desired hub mode configuration, the BCM4339 can boot up showing the three ports connected to logical USB devices internal to the BCM4339: a generic Bluetooth device, a mouse, and a keyboard. In this mode, the mouse and keyboard are emulated devices, since they connect to real HID devices via a Bluetooth link. The Bluetooth link to these HID devices is hidden from the USB host. To the host, the mouse and/or keyboard appear to be directly connected to the USB port. This Broadcom proprietary architecture is called USB HID Emulation (UHE).

The USB device, configuration, and string descriptors are fully programmable, allowing manufacturers to customize the descriptors, including vendor and product IDs, the BCM4339 uses to identify itself on the USB port. To make custom USB descriptor information available at boot time, stored it in external NVRAM.

Despite the mode of operation (single peripheral or hub), the Bluetooth device is configured to include the following interfaces:

Interface 0	Contains a Control endpoint (Endpoint 0x00) for HCI commands, a Bulk In Endpoint (Endpoint 0x82) for receiving ACL data, a Bulk Out Endpoint (Endpoint 0x02) for transmitting ACL data, and an Interrupt Endpoint (Endpoint 0x81) for HCI events.
Interface 1	Contains Isochronous In and Out endpoints (Endpoints 0x83 and 0x03) for SCO traffic. Several alternate Interface 1 settings are available for reserving the proper bandwidth of isochronous data (depending on the application).
Interface 2	Contains Bulk In and Bulk Out endpoints (Endpoints 0x84 and 0x04) used for proprietary testing and debugging purposes. These endpoints can be ignored during normal operation.

USB Hub and UHE Support

The BCM4339 supports the USB hub and device model (USB, Revision 2.0, full-speed compliant). Optional mouse and keyboard devices utilize Broadcom's proprietary USB HID Emulation (UHE) architecture, which allows these devices appear as standalone HID devices even though connected through a Bluetooth link.

The presence of UHE devices requires the hub to be enabled. The BCM4339 cannot appear as a single keyboard or a single mouse device without the hub. Once either mouse or keyboard UHE device is enabled, the hub must also be enabled.

When the hub is enabled, the BCM4339 handles all standard USB functions for the following devices:

- HID keyboard
- HID mouse
- Bluetooth

All hub and device descriptors are firmware-programmable. This USB compound device configuration (see [Figure 16 on page 57](#)) supports up to three downstream ports. This configuration can also be programmed to a single USB device core. The device automatically detects activity on the USB interface when connected. Therefore, no special configuration is needed to select HCI as the transport.

The hub's downstream port definition is as follows:

- Port 1 USB lite device core (for HID applications)
- Port 2 USB lite device core (for HID applications)
- Port 3 USB full device core (for Bluetooth applications)

When operating in hub mode, all three internal devices do not have to be enabled. Each internal USB device can be optionally enabled. The configuration record in NVRAM determines which devices are present.

USB Full-Speed Timing

[Table 12](#) shows timing specifications for the $V_{DD_USB} = 3.3V$, $V_{SS} = 0V$, and $T_A = 0^{\circ}C$ to $85^{\circ}C$ operating temperature range.

Table 12: USB Full-Speed Timing Specifications

Reference	Characteristics	Minimum	Maximum	Unit
1	Transition rise time	4	20	ns
2	Transition fall time	4	20	ns
3	Rise/fall timing matching	90	111	%
4	Full-speed data rate	12 – 0.25%	12 + 0.25%	Mb/s

Figure 17: USB Full-Speed Timing

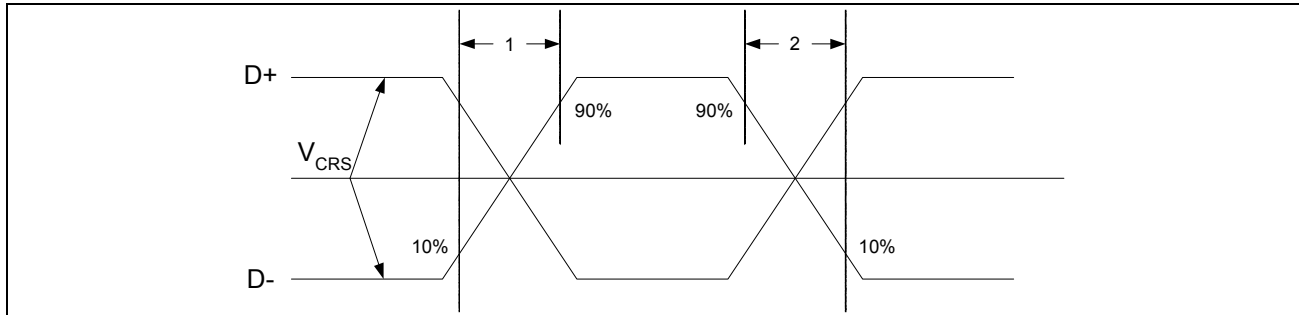

UART Interface

The BCM4339 shares a single UART for Bluetooth and FM. The UART is a standard 4-wire interface (RX, TX, RTS, and CTS) with adjustable baud rates from 9600 bps to 4.0 Mbps. The interface features an automatic baud rate detection capability that returns a baud rate selection. Alternatively, the baud rate may be selected through a vendor-specific UART HCI command.

UART has a 1040-byte receive FIFO and a 1040-byte transmit FIFO to support EDR. Access to the FIFOs is conducted through the AHB interface through either DMA or the CPU. The UART supports the Bluetooth 4.1 UART HCI specification: H4, a custom Extended H4, and H5. The default baud rate is 115.2 Kbaud.

The UART supports the 3-wire H5 UART transport, as described in the Bluetooth specification (“Three-wire UART Transport Layer”). Compared to H4, the H5 UART transport reduces the number of signal lines required by eliminating the CTS and RTS signals.

The BCM4339 UART can perform XON/XOFF flow control and includes hardware support for the Serial Line Input Protocol (SLIP). It can also perform wake-on activity. For example, activity on the RX or CTS inputs can wake the chip from a sleep state.

Normally, the UART baud rate is set by a configuration record downloaded after device reset, or by automatic baud rate detection, and the host does not need to adjust the baud rate. Support for changing the baud rate during normal HCI UART operation is included through a vendor-specific command that allows the host to adjust the contents of the baud rate registers. The BCM4339 UARTs operate correctly with the host UART as long as the combined baud rate error of the two devices is within $\pm 2\%$.

Table 13: Example of Common Baud Rates

Desired Rate	Actual Rate	Error (%)
4000000	4000000	0.00
3692000	3692308	0.01
3000000	3000000	0.00
2000000	2000000	0.00
1500000	1500000	0.00
1444444	1454544	0.70
921600	923077	0.16
460800	461538	0.16
230400	230796	0.17
115200	115385	0.16
57600	57692	0.16
38400	38400	0.00
28800	28846	0.16
19200	19200	0.00
14400	14423	0.16
9600	9600	0.00

Figure 18: UART Timing

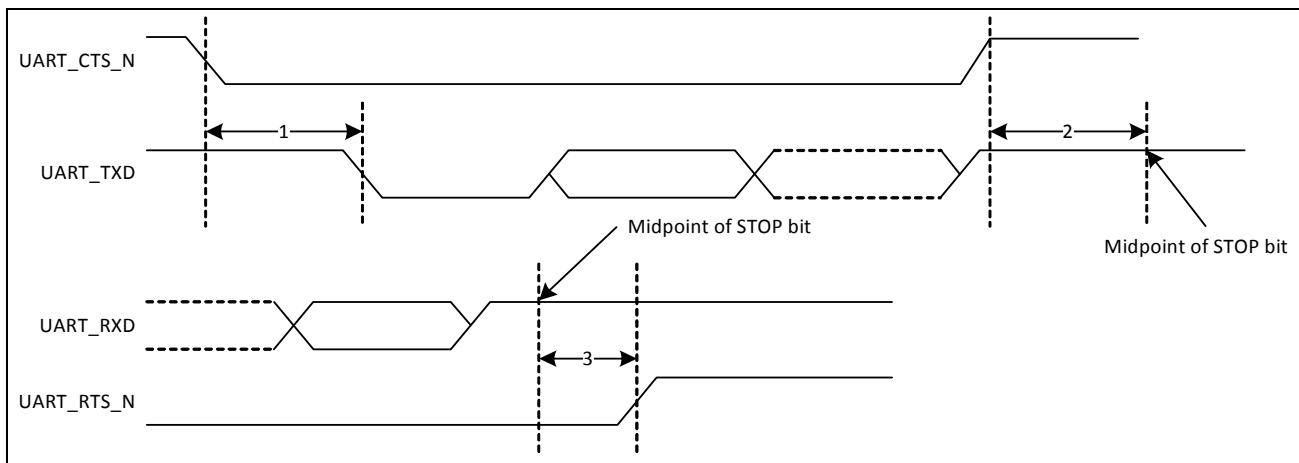

Table 14: UART Timing Specifications

Ref No.	Characteristics	Min.	Typ.	Max.	Unit
1	Delay time, UART_CTS_N low to UART_TXD valid	–	–	1.5	Bit period
2	Setup time, UART_CTS_N high before midpoint of stop bit	–	–	0.5	Bit period
3	Delay time, midpoint of stop bit to UART_RTS_N high	–	–	0.5	Bit period

I²S Interface

The BCM4339 supports two independent I²S digital audio ports: one for Bluetooth audio, and one for high-fidelity FM audio. The I²S interface for FM audio supports both master and slave modes. The I²S signals are:

- I²S clock: I²S SCK
- I²S Word Select: I²S WS
- I²S Data Out: I²S SDO
- I²S Data In: I²S SDI

I²S SCK and I²S WS become outputs in master mode and inputs in slave mode, while I²S SDO always stays as an output. The channel word length is 16 bits and the data is justified so that the MSB of the left-channel data is aligned with the MSB of the I²S bus, per the I²S specification. The MSB of each data word is transmitted one bit clock cycle after the I²S WS transition, synchronous with the falling edge of bit clock. Left-channel data is transmitted when I²S WS is low, and right-channel data is transmitted when I²S WS is high. Data bits sent by the BCM4339 are synchronized with the falling edge of I2S_SCK and should be sampled by the receiver on the rising edge of I2S_SSCK.

The clock rate in master mode is either of the following:

$$48 \text{ kHz} \times 32 \text{ bits per frame} = 1.536 \text{ MHz}$$

$$48 \text{ kHz} \times 50 \text{ bits per frame} = 2.400 \text{ MHz}$$

The master clock is generated from the input reference clock using a N/M clock divider.

In the slave mode, any clock rate is supported to a maximum of 3.072 MHz.

I²S Timing



Note: Timing values specified in [Table 15](#) are relative to high and low threshold levels.

Table 15: Timing for I²S Transmitters and Receivers

	Transmitter				Receiver				Notes
	Lower Limit		Upper Limit		Lower Limit		Upper Limit		
	Min.	Max.	Min.	Max.	Min.	Max.	Min.	Max.	
Clock Period T	T _{tr}	–	–	–	T _r	–	–	–	a
Master Mode: Clock generated by transmitter or receiver									
HIGH t _{HC}	0.35T _{tr}	–	–	–	0.35T _{tr}	–	–	–	b
LOW t _{LC}	0.35T _{tr}	–	–	–	0.35T _{tr}	–	–	–	b
Slave Mode: Clock accepted by transmitter or receiver									
HIGH t _{HC}	–	0.35T _{tr}	–	–	–	0.35T _{tr}	–	–	c
LOW t _{LC}	–	0.35T _{tr}	–	–	–	0.35T _{tr}	–	–	c
Rise time t _{RC}	–	–	0.15T _{tr}	–	–	–	–	–	d
Transmitter									
Delay t _{dtr}	–	–	–	0.8T	–	–	–	–	e
Hold time t _{htr}	0	–	–	–	–	–	–	–	d
Receiver									
Setup time t _{sr}	–	–	–	–	–	0.2T _r	–	–	f
Hold time t _{hr}	–	–	–	–	–	0	–	–	f

- a. The system clock period T must be greater than T_{tr} and T_r because both the transmitter and receiver have to be able to handle the data transfer rate.
- b. At all data rates in master mode, the transmitter or receiver generates a clock signal with a fixed mark/space ratio. For this reason, t_{HC} and t_{LC} are specified with respect to T.
- c. In slave mode, the transmitter and receiver need a clock signal with minimum HIGH and LOW periods so that they can detect the signal. So long as the minimum periods are greater than 0.35T_r, any clock that meets the requirements can be used.
- d. Because the delay (t_{dtr}) and the maximum transmitter speed (defined by T_{tr}) are related, a fast transmitter driven by a slow clock edge can result in t_{dtr} not exceeding t_{RC} which means t_{htr} becomes zero or negative. Therefore, the transmitter has to guarantee that t_{htr} is greater than or equal to zero, so long as the clock rise-time t_{RC} is not more than t_{RCmax}, where t_{RCmax} is not less than 0.15T_{tr}.
- e. To allow data to be clocked out on a falling edge, the delay is specified with respect to the rising edge of the clock signal and T, always giving the receiver sufficient setup time.
- f. The data setup and hold time must not be less than the specified receiver setup and hold time.



Note: The time periods specified in [Figure 19](#) and [Figure 20](#) are defined by the transmitter speed. The receiver specifications must match transmitter performance.

Figure 19: I²S Transmitter Timing

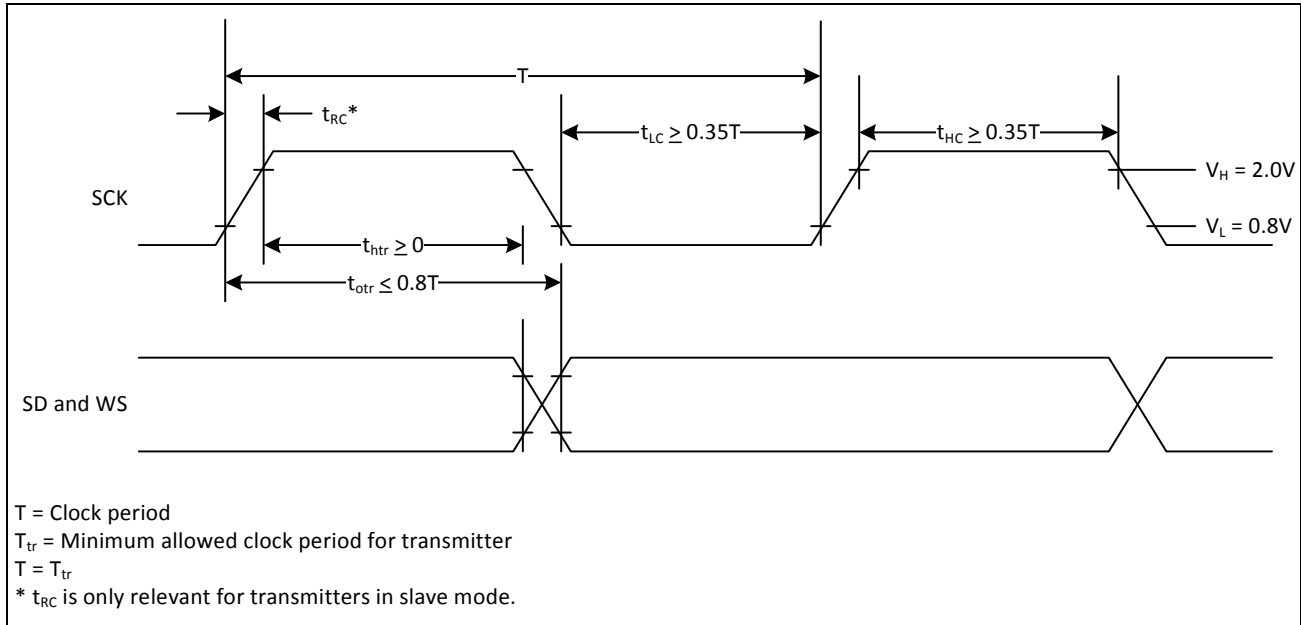
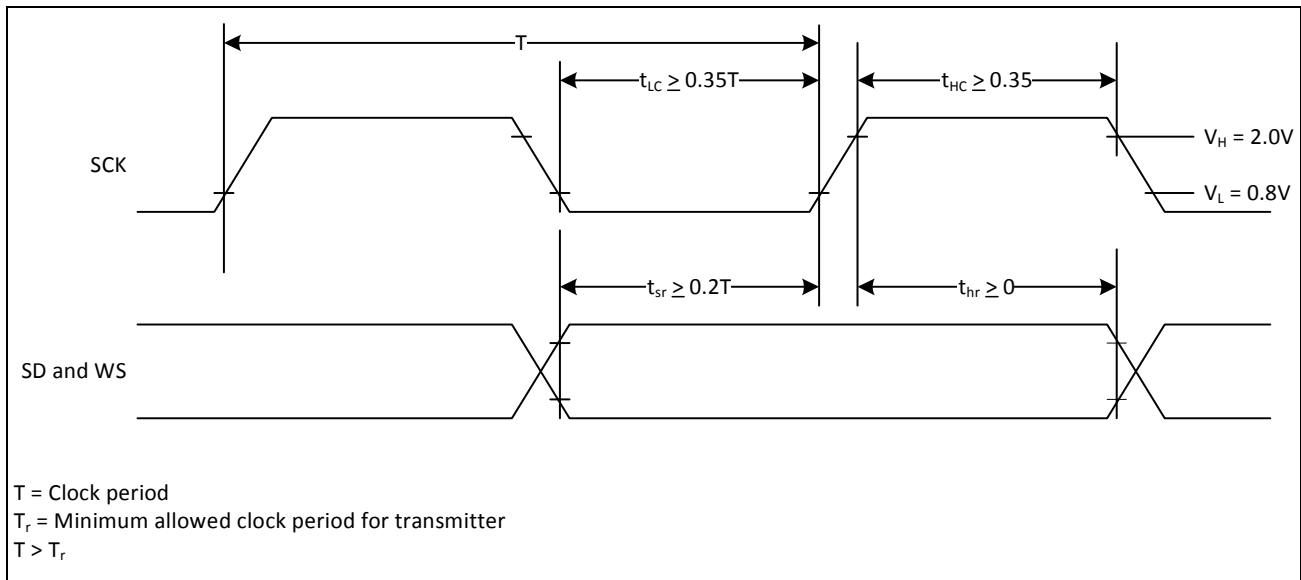

Figure 20: I²S Receiver Timing



Section 8: FM Receiver Subsystem

FM Radio

The BCM4339 includes a completely integrated FM radio receiver with RDS/RBDS covering all FM bands from 65 MHz to 108 MHz. The receiver is controlled through commands on the HCI. FM received audio is available in analog form or in digital form through I²S or PCM. The FM radio operates from the external clock reference.

Digital FM Audio Interfaces

The FM audio can be transmitted via the shared PCM and I²S pins, and the sampling rate is programmable. The BCM4339 supports a three-wire PCM or I²S audio interface in either master or slave configuration. The master or slave configuration is selected using vendor specific commands over the HCI interface. In addition, multiple sampling rates are supported, derived from either the FM or Bluetooth clocks. In master mode, the clock rate is either of the following:

- 48 kHz x 32 bits per frame = 1.536 MHz
- 48 kHz x 50 bits per frame = 2.400 MHz

In slave mode, any clock rate is supported up to a maximum of 3.072 MHz.

FM Over Bluetooth

The BCM4339 can output received FM audio onto Bluetooth using one of following three links: eSCO, WBS, and A2DP. In all of the above modes, once the link has been set up, the host processor can enter sleep mode while the BCM4339 continues to stream FM audio to the remote Bluetooth device, allowing the system current consumption to be minimized.

eSCO

In this use case, the stereo FM audio is downsampled to 8 kHz and a mono or stereo stream is then sent through the Bluetooth eSCO link to a remote Bluetooth device, typically a headset. Two Bluetooth voice connections must be used to transport stereo.

Wide Band Speech Link

In this case, the stereo FM audio is downsampled to 16 kHz and a mono or stereo stream is then sent through the Bluetooth wideband speech link to a remote Bluetooth device, typically a headset. Two Bluetooth voice connections must be used to transport stereo.

A2DP

In this case, the stereo FM audio is encoded by the on-chip SBC encoder and transported as an A2DP link to a remote Bluetooth device. Sampling rates of 48 kHz, 44.1 kHz, and 32 kHz joint stereo are supported. An A2DP “lite” stack is implemented in the BCM4339 to support this use case, which eliminates the need to route the SBC-encoded audio back to the host to create the A2DP packets.

Autotune and Search Algorithms

The BCM4339 supports a number of FM search and tune functions that allows the host to implement many convenient user functions, which are accessed through the Broadcom FM stack.

- Tune to Play—Allows the FM receiver to be programmed to a specific frequency.
- Search for SNR > Threshold—Checks the power level of the available channel and the estimated SNR of the channel to help achieve precise control of the expected sound quality for the selected FM channel. Specifically, the host can adjust its SNR requirements to retrieve a signal with a specific sound quality, or adjust this to return the weakest channels.
- Alternate Frequency Jump—Allows the FM receiver to automatically jump to an alternate FM channel that carries the same information, but has a better SNR. For example, when traveling, a user may pass through a region where a number of channels carry the same station. When the user passes from one area to the next, the FM receiver can automatically switch to another channel with a stronger signal to spare the user from having to manually change the channel to continue listening to the same station.

Audio Features

A number of features are implemented in the BCM4339 to provide the best possible audio experience for the user.

- Mono/Stereo Blend or Switch—The BCM4339 provides automatic control of the stereo or mono settings based on the FM signal carrier-to-noise ratio (C/N). This feature is used to maintain the best possible audio SNR based on the FM channel condition. Two modes of operation are supported:
 - Blend: In this mode, fine control of stereo separation is used to achieve optimal audio quality over a wide range of input C/N. The amount of separation is fully programmable. In [Figure 21](#), the separation is programmed to maintain a minimum 50 dB SNR across the blend range.
 - Extended blend: In this mode, stereo separation is maximized across a wide range of input CNR. Broadcom static suppression typically gives a static-free user experience to within 3 dB of ultimate sensitivity.

Figure 21: Example Blend/Switch Usage

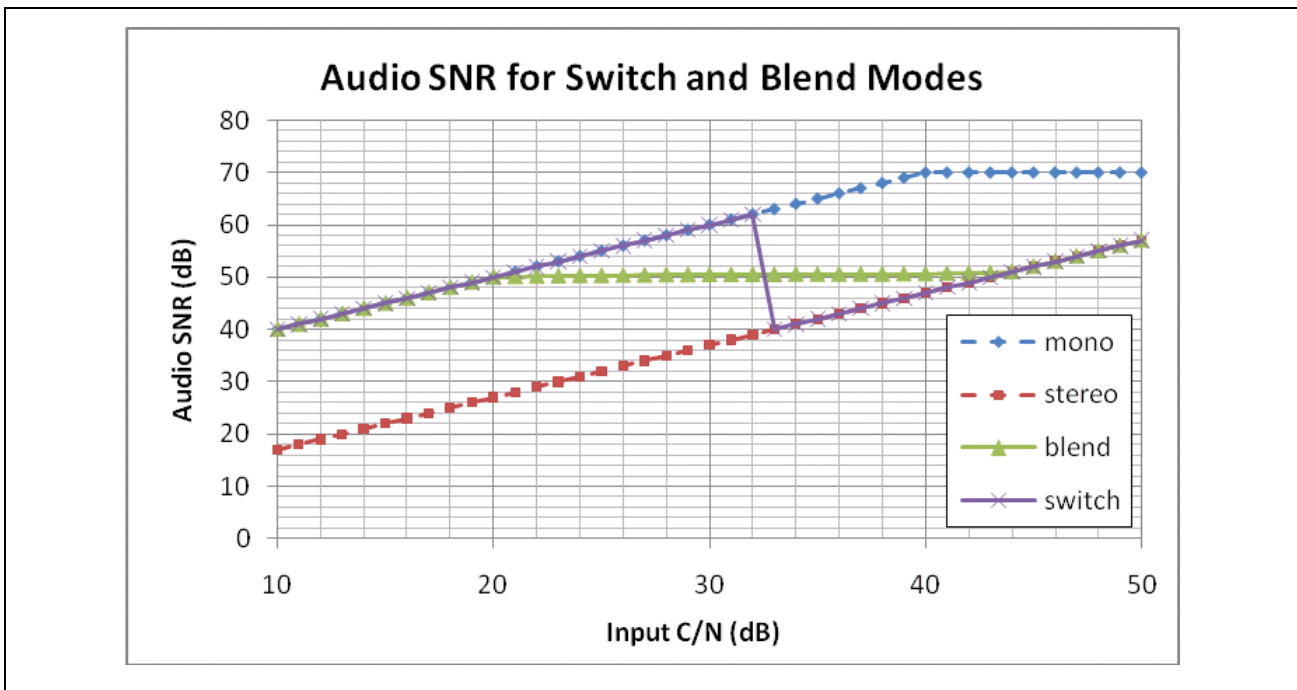

- Switch—In this mode, the audio switches from full stereo to full mono at a predetermined level to maintain optimal audio quality. The stereo-to-mono switch point and the mono-to-stereo switch points are fully programmable to provide the desired amount of audio SNR. In [Figure 22](#), the switch point is programmed to switch to mono to maintain a 40 dB SNR.

Figure 22: Example Blend/Switch Separation

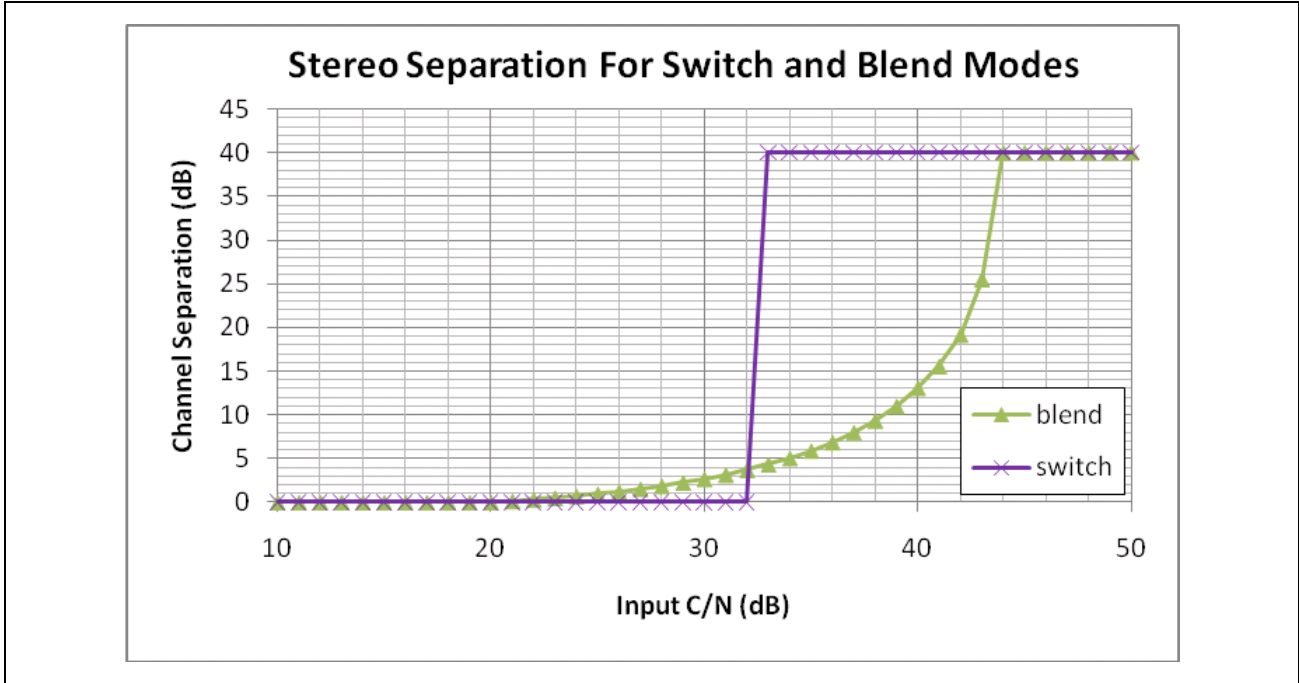

- **Soft Mute**—Improves the user experience by dynamically muting the output audio proportionate to the FM signal C/N. This prevents the user from being assaulted with a blast of static. The mute characteristic is fully programmable to accommodate fine tuning of the output signal level. An example mute characteristic is shown in [Figure 23](#).

Figure 23: Example Soft Mute Characteristic

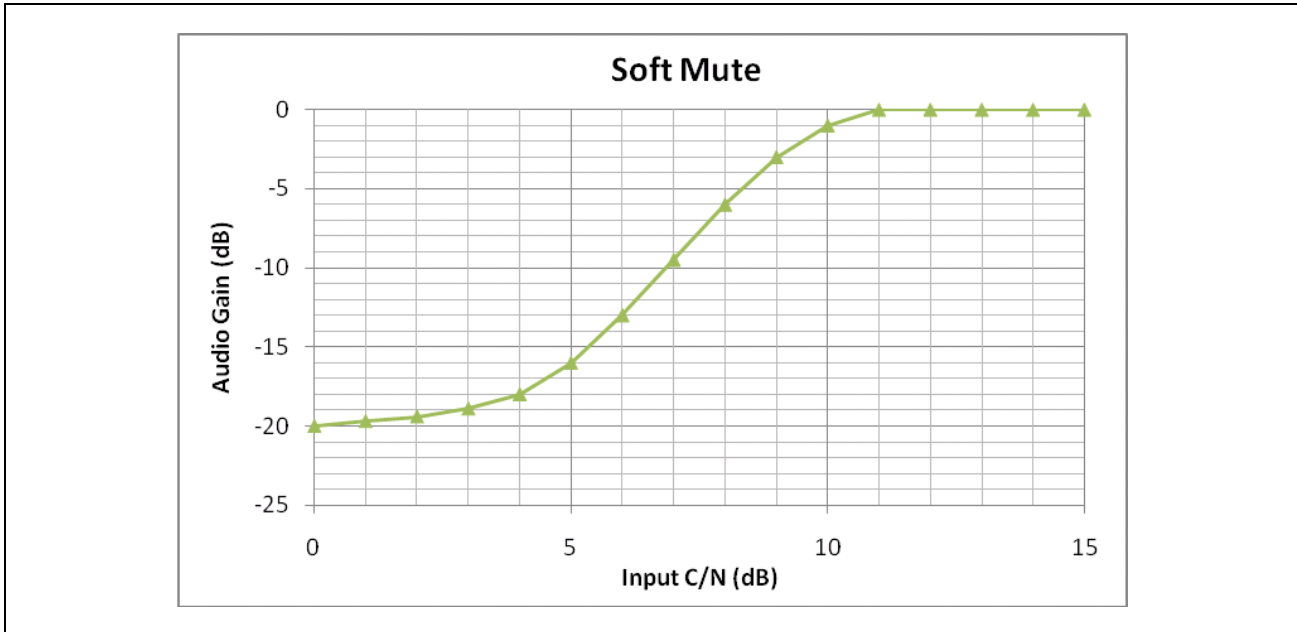

- **High Cut**—A programmable high-cut filter is provided to reduce the amount of high-frequency noise caused by static in the output audio signal. Like the soft mute circuit, it is fully programmable to allow for any amount of high cut based on the FM signal C/N.
- **Audio Pause Detect**—The FM receiver monitors the magnitude of the audio signal and notifies the host through an interrupt when the magnitude of the signal has fallen below the threshold set for a programmable period. This feature can be used to provide alternate frequency jumps during periods of silence to minimize disturbances to the listener. Filtering techniques are used within the audio pause detection block to provide more robust presence-to-silence detection and silence-to-presence detection.
- **Automatic Antenna Tuning**—The BCM4339 has an on-chip automatic antenna tuning network. When used with a single off-chip inductor, the on-chip circuitry automatically chooses an optimal on-chip matching component to obtain the highest signal strength for the desired frequency. The high-Q nature of this matching network simultaneously provides out-of-band blocking protection as well as a reduction of radiated spurious emissions from the FM antenna. It is designed to accommodate a wide range of external wire antennas.

RDS/RBDS

The BCM4339 integrates a RDS/RBDS modem and codec, the decoder includes programmable filtering and buffering functions, and the encoder includes the option to encode messages to PS or RT frame format with programmable scrolling in PS mode. The RDS/RBDS data can be read out in receive mode or delivered in transmit mode through either the HCI interface.

In addition, the RDS/RBDS functionality supports the following:

Receive

- Block decoding, error correction and synchronization
- Flywheel synchronization feature, allowing the host to set parameters for acquisition, maintenance, and loss of sync. (It is possible to set up the BCM4339 such that synch is achieved when a minimum of two good blocks (error free) are decoded in sequence. The number of good blocks required for sync is programmable.)
- Storage capability up to 126 blocks of RDS data
- Full or partial block B match detect and interrupt to host
- Audio pause detection with programmable parameters
- Program Identification (PI) code detection and interrupt to host
- Automatic frequency jump
- Block E filtering
- Soft mute
- Signal dependent mono/stereo blend
- Programmable pre-emphasis

Section 9: WLAN Global Functions

WLAN CPU and Memory Subsystem

The BCM4339 WLAN section includes an integrated ARM Cortex-R4™ 32-bit processor with internal RAM and ROM. The ARM Cortex-R4 is a low-power processor that features low gate count, low interrupt latency, and low-cost debug capabilities. It is intended for deeply embedded applications that require fast interrupt response features. Delivering more than 30% performance gain over ARM7TDMI, the ARM Cortex-R4 implements the ARM v7-R architecture with support for the Thumb®-2 instruction set.

At 0.19 $\mu\text{W}/\text{MHz}$, the Cortex-R4 is the most power efficient general-purpose microprocessor available, outperforming 8- and 16-bit devices on MIPS/ μW . It supports integrated sleep modes.

Using multiple technologies to reduce cost, the ARM Cortex-R4 offers improved memory utilization, reduced pin overhead, and reduced silicon area. It supports independent buses for Code and Data access (ICode/DCode and System buses), and extensive debug features including real time trace of program execution.

On-chip memory for the CPU includes 768 KB SRAM and 640 KB ROM.

One-Time Programmable Memory

Various hardware configuration parameters may be stored in an internal One-Time Programmable (OTP) memory, which is read by the system software after device reset. In addition, customer-specific parameters, including the system vendor ID and the MAC address can be stored, depending on the specific board design. Customer accessible OTP memory is 502 bytes.

The initial state of all bits in an unprogrammed OTP device is 0. After any bit is programmed to a 1, it cannot be reprogrammed to 0. The entire OTP array can be programmed in a single write cycle using a utility provided with the Broadcom WLAN manufacturing test tools. Alternatively, multiple write cycles can be used to selectively program specific bytes, but only bits which are still in the 0 state can be altered during each programming cycle.

Prior to OTP memory programming, all values should be verified using the appropriate editable nvram.txt file, which is provided with the reference board design package.

GPIO Interface

The following number of general-purpose I/O (GPIO) pins are available on the WLAN section of the BCM4339 that can be used to connect to various external devices:

- FCBGA package – 12 GPIOs
- WLBGA package – 9 GPIOs
- WLCSP package – 16 GPIOs

Upon power up and reset, these pins become tristated. Subsequently, they can be programmed to be either input or output pins via the GPIO control register. In addition, the GPIO pins can be assigned to various other functions (see [Table 28: “BCM4339 GPIO/SDIO Alternative Signal Functions,” on page 118](#)).

External Coexistence Interface

An external handshake interface is available to enable signaling between the device and an external co-located wireless device, such as GPS, WiMAX, LTE, or UWB, to manage wireless medium sharing for optimum performance.

[Figure 24](#) shows the LTE coexistence interface. See [Table 28: “BCM4339 GPIO/SDIO Alternative Signal Functions,” on page 118](#) for details on multiplexed signals such as the GPIO pins.

See [Table 13: “Example of Common Baud Rates,” on page 60](#) for UART baud rates.

Figure 24: Broadcom GCI or BT-SIG Mode LTE Coexistence Interface for BCM4339

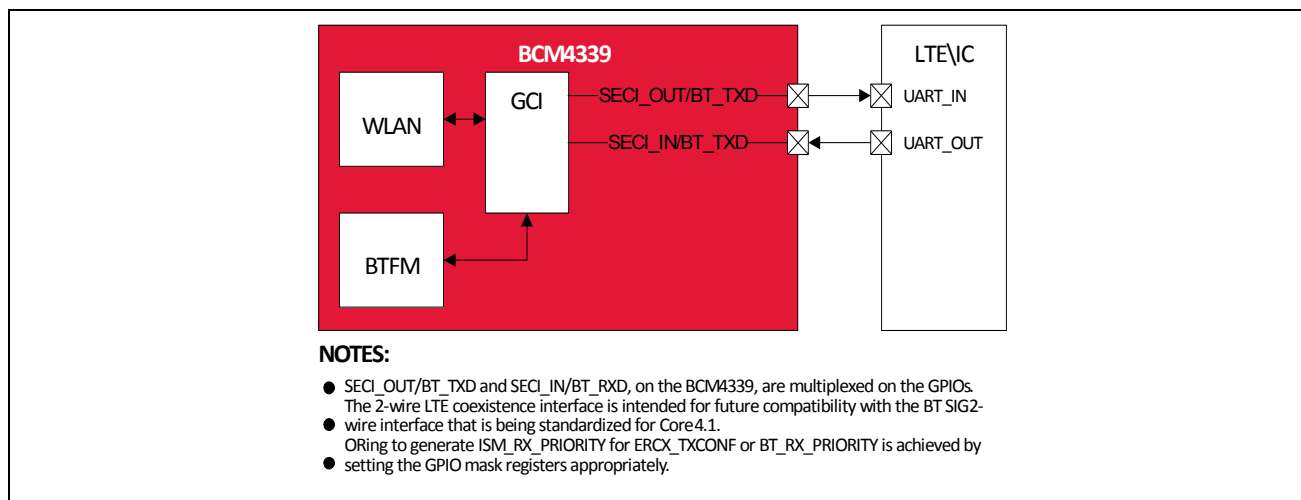

UART Interface

One 2-wire UART interface can be enabled by software as an alternate function on GPIO pins (see [Table 28: “BCM4339 GPIO/SDIO Alternative Signal Functions,” on page 118](#)). Provided primarily for debugging during development, this UART enables the BCM4339 to operate as RS-232 data termination equipment (DTE) for exchanging and managing data with other serial devices. It is compatible with the industry standard 16550 UART, and provides a FIFO size of 64×8 in each direction.

JTAG Interface

The BCM4339 supports the IEEE 1149.1 JTAG boundary scan standard for performing device package and PCB assembly testing during manufacturing. In addition, the JTAG interface allows Broadcom to assist customers by using proprietary debug and characterization test tools during board bringup. Therefore, it is highly recommended to provide access to the JTAG pins by means of test points or a header on all PCB designs.

See [Table 28: “BCM4339 GPIO/SDIO Alternative Signal Functions,” on page 118](#) for JTAG pin assignments.

SPROM Interface (FCBGA Package only)

For use only with the PCIe Interface in the FCBGA package, various hardware configuration parameters may be stored in an external SPROM instead of the OTP. The SPROM is read by system software after device reset. In addition, depending on the board design, customer-specific parameters may be stored in SPROM.

The four SPROM control signals —SPROM_CS, SPROM_CLK, SPROM_DIN, and SPROM_DOUT are multiplexed on the SDIO interface (see [Table 28: “BCM4339 GPIO/SDIO Alternative Signal Functions,” on page 118](#) for additional details). By default, the SPROM interface supports 2 kbit serial SPROMs, and it can also support 4 kbit and 16 kbit serial SPROMs by using the appropriate strapping option.

Section 10: WLAN Host Interfaces

SDIO v3.0

The BCM4339 WLAN section supports SDIO version 3.0, including the new UHS-I modes:

- DS: Default speed (DS) up to 25 MHz, including 1- and 4-bit modes (3.3V signaling).
- HS: High speed up to 50 MHz (3.3V signaling).
- SDR12: SDR up to 25 MHz (1.8V signaling).
- SDR25: SDR up to 50 MHz (1.8V signaling).
- SDR50: SDR up to 100 MHz (1.8V signaling).
- SDR104: SDR up to 208 MHz (1.8V signaling).
- DDR50: DDR up to 50 MHz (1.8V signaling).



Note: The BCM4339 is backward compatible with SDIO v2.0 host interfaces.

The SDIO interface also has the ability to map the interrupt signal on to a GPIO pin for applications requiring an interrupt different from the one provided by the SDIO interface. The ability to force control of the gated clocks from within the device is also provided. SDIO mode is enabled by strapping options. Refer to [Table 21 on page 114](#) WLAN GPIO Functions and Strapping Options.

The following three functions are supported:

- Function 0 Standard SDIO function (Max. BlockSize/ByteCount = 32B)
- Function 1 Backplane Function to access the internal system-on-chip (SoC) address space (Max. BlockSize/ByteCount = 64B)
- Function 2 WLAN Function for efficient WLAN packet transfer through DMA (Max. BlockSize/ByteCount = 512B)

SDIO Pins

Table 16: SDIO Pin Description

SD 4-Bit Mode		SD 1-Bit Mode		gSPI Mode	
DATA0	Data line 0	DATA	Data line	DO	Data output
DATA1	Data line 1 or Interrupt	IRQ	Interrupt	IRQ	Interrupt
DATA2	Data line 2 or Read Wait	RW	Read Wait	NC	Not used
DATA3	Data line 3	N/C	Not used	CS	Card select
CLK	Clock	CLK	Clock	SCLK	Clock
CMD	Command line	CMD	Command line	DI	Data input

Figure 25: Signal Connections to SDIO Host (SD 4-Bit Mode)

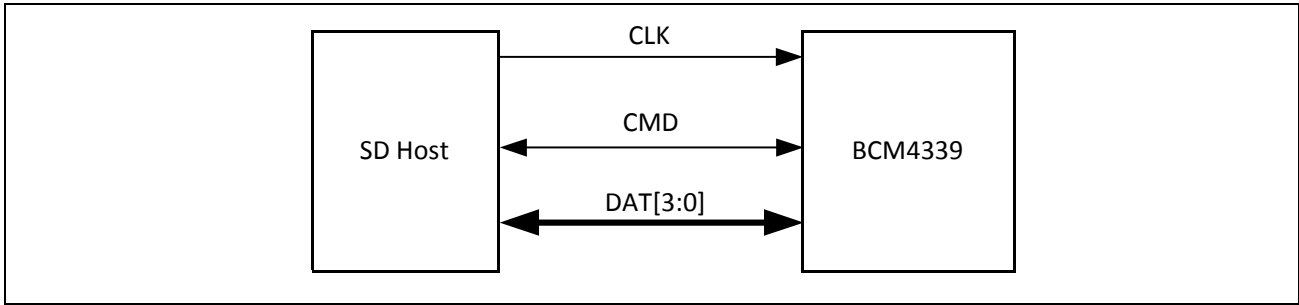
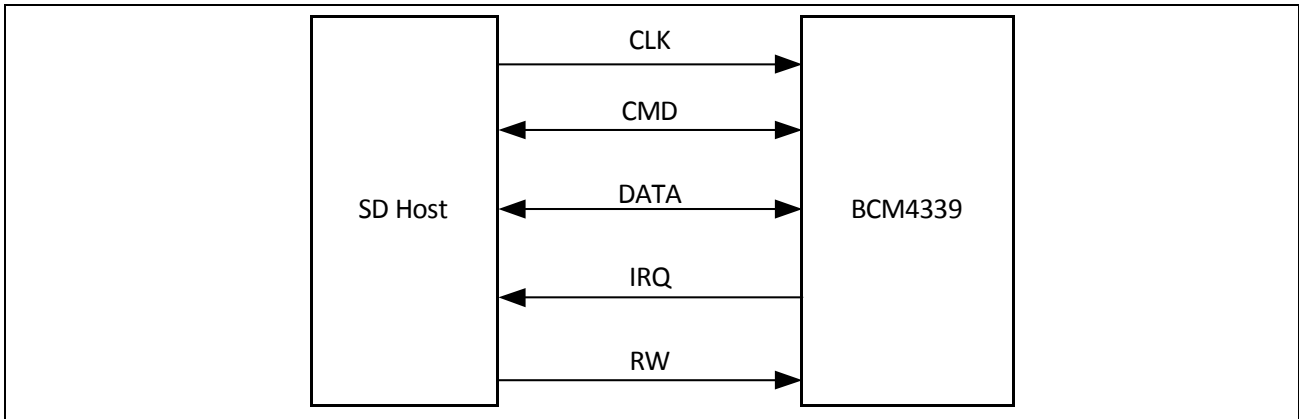

Figure 26: Signal Connections to SDIO Host (SD 1-Bit Mode)



Note: Per Section 6 of the SDIO specification, pull-ups in the 10 kΩ to 100 kΩ range are required on the four DATA lines and the CMD line. This requirement must be met during all operating states either through the use of external pull-up resistors or through proper programming of the SDIO host's internal pull-ups.

Generic SPI Mode

In addition to the full SDIO mode, the BCM4339 includes the option of using the simplified generic SPI (gSPI) interface/protocol. Characteristics of the gSPI mode include:

- Supports up to 48 MHz operation
- Supports fixed delays for responses and data from device
- Supports alignment to host gSPI frames (16 or 32 bits)
- Supports up to 2 KB frame size per transfer
- Supports little endian (default) and big endian configurations
- Supports configurable active edge for shifting
- Supports packet transfer through DMA for WLAN

gSPI mode is enabled using the strapping option pins strap_host_ifc_[3:1].

Figure 27: Signal Connections to SDIO Host (gSPI Mode)

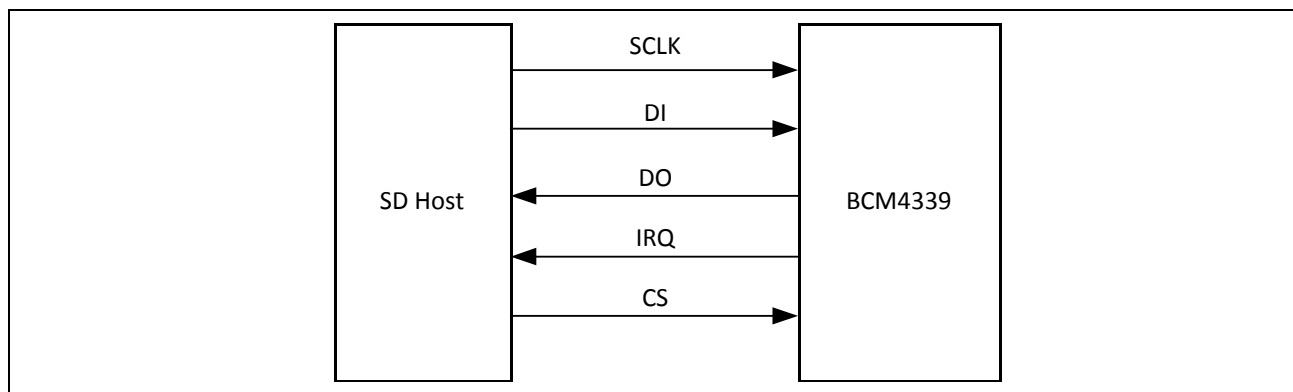

SPI Protocol

The SPI protocol supports both 16-bit and 32-bit word operation. Byte endianness is supported in both modes. [Figure 28](#) and [Figure 29](#) show the basic write and write/read commands.

Figure 28: gSPI Write Protocol

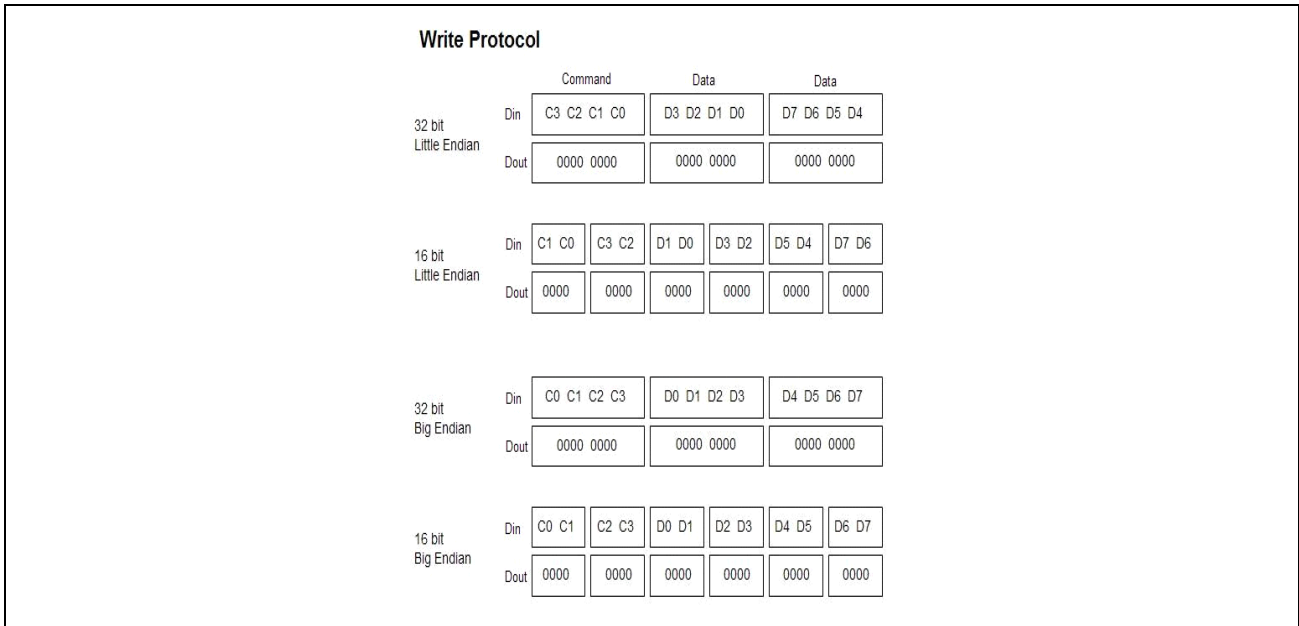
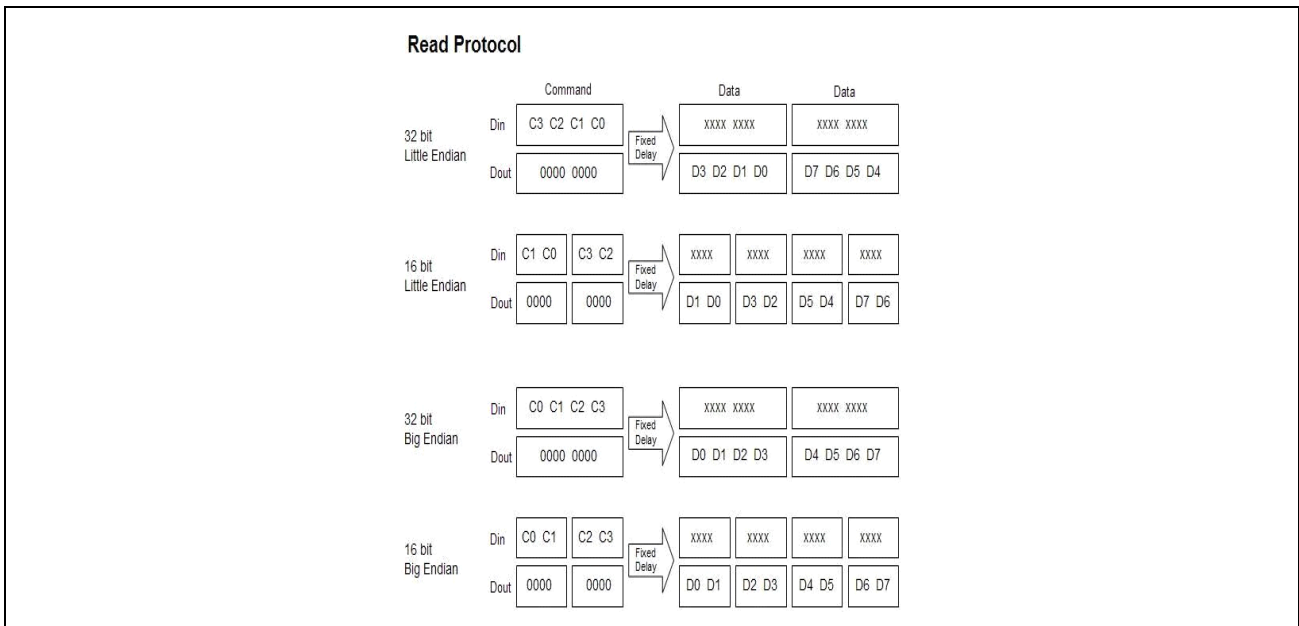

Figure 29: gSPI Read Protocol



Command Structure

The gSPI command structure is 32 bits. The bit positions and definitions are as shown in [Figure 30](#).

Figure 30: gSPI Command Structure

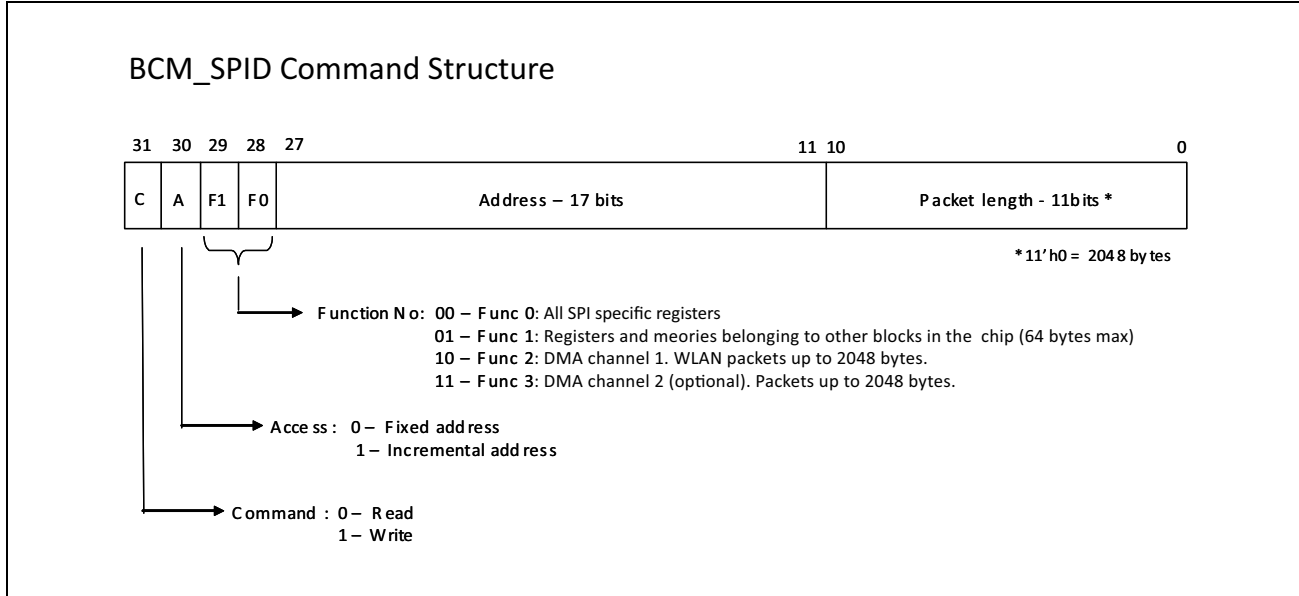

Write

The host puts the first bit of the data onto the bus half a clock-cycle before the first active edge following the CS going low. The following bits are clocked out on the falling edge of the gSPI clock. The device samples the data on the active edge.

Write/Read

The host reads on the rising edge of the clock requiring data from the device to be made available before the first rising clock edge of the clock burst for the data. The last clock edge of the fixed delay word can be used to represent the first bit of the following data word. This allows data to be ready for the first clock edge without relying on asynchronous delays.

Read

The read command always follows a separate write to set up the WLAN device for a read. This command differs from the write/read command in the following respects: a) chip selects go high between the command/address and the data and b) the time interval between the command/address is not fixed.

Status

The gSPI interface supports status notification to the host after a read/write transaction. This status notification provides information about any packet errors, protocol errors, information about available packet in the RX queue, etc. The status information helps in reducing the number of interrupts to the host. The status-reporting feature can be switched off using a register bit, without any timing overhead. The gSPI bus timing for read/write transactions with and without status notification are as shown in [Figure 31](#) and [Figure 32 on page 79](#). See [Table 17 on page 79](#) for information on status field details.

Figure 31: gSPI Signal Timing Without Status (32-bit Big Endian)

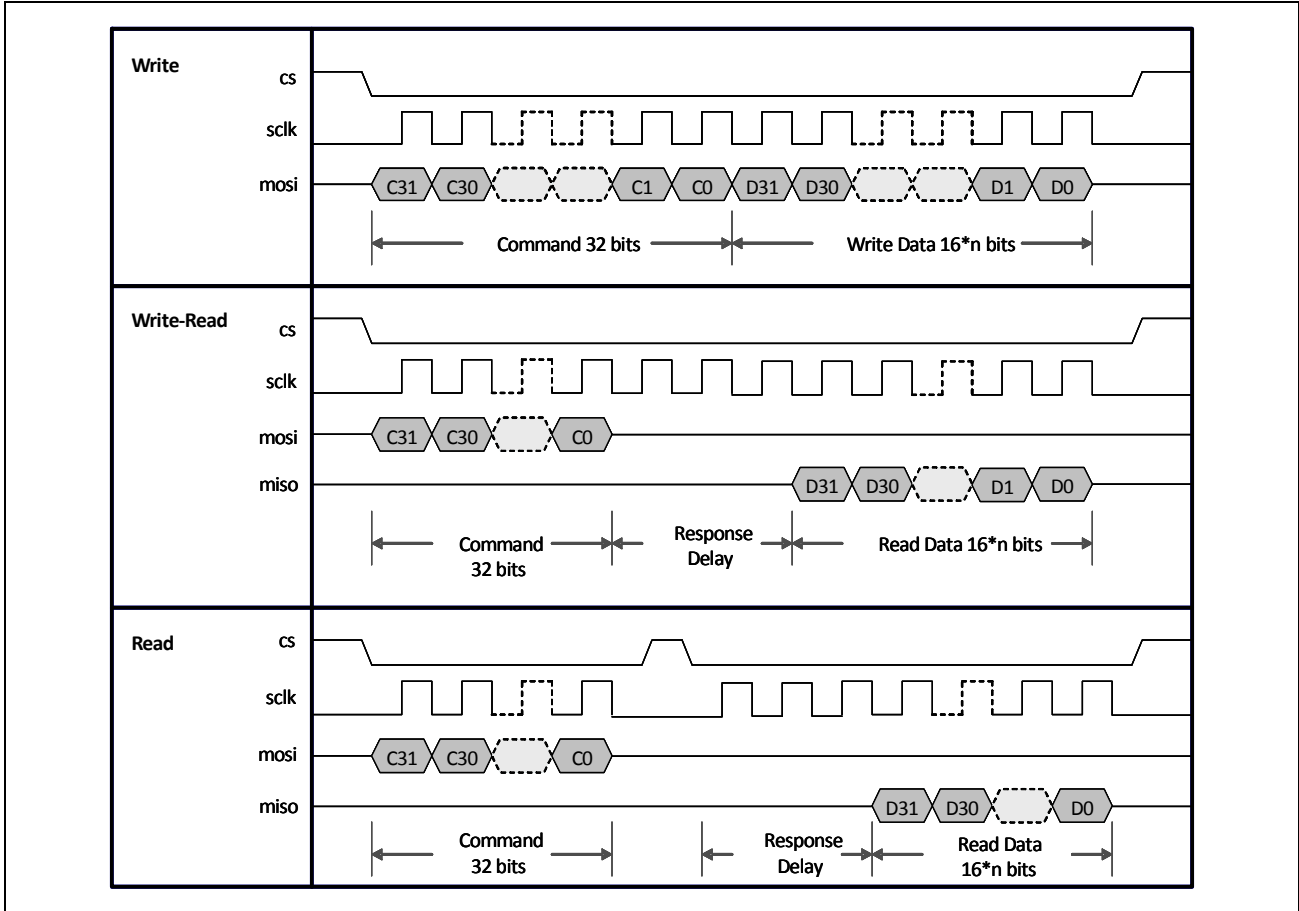

Figure 32: gSPI Signal Timing with Status (Response Delay = 0; 32-bit Big Endian)

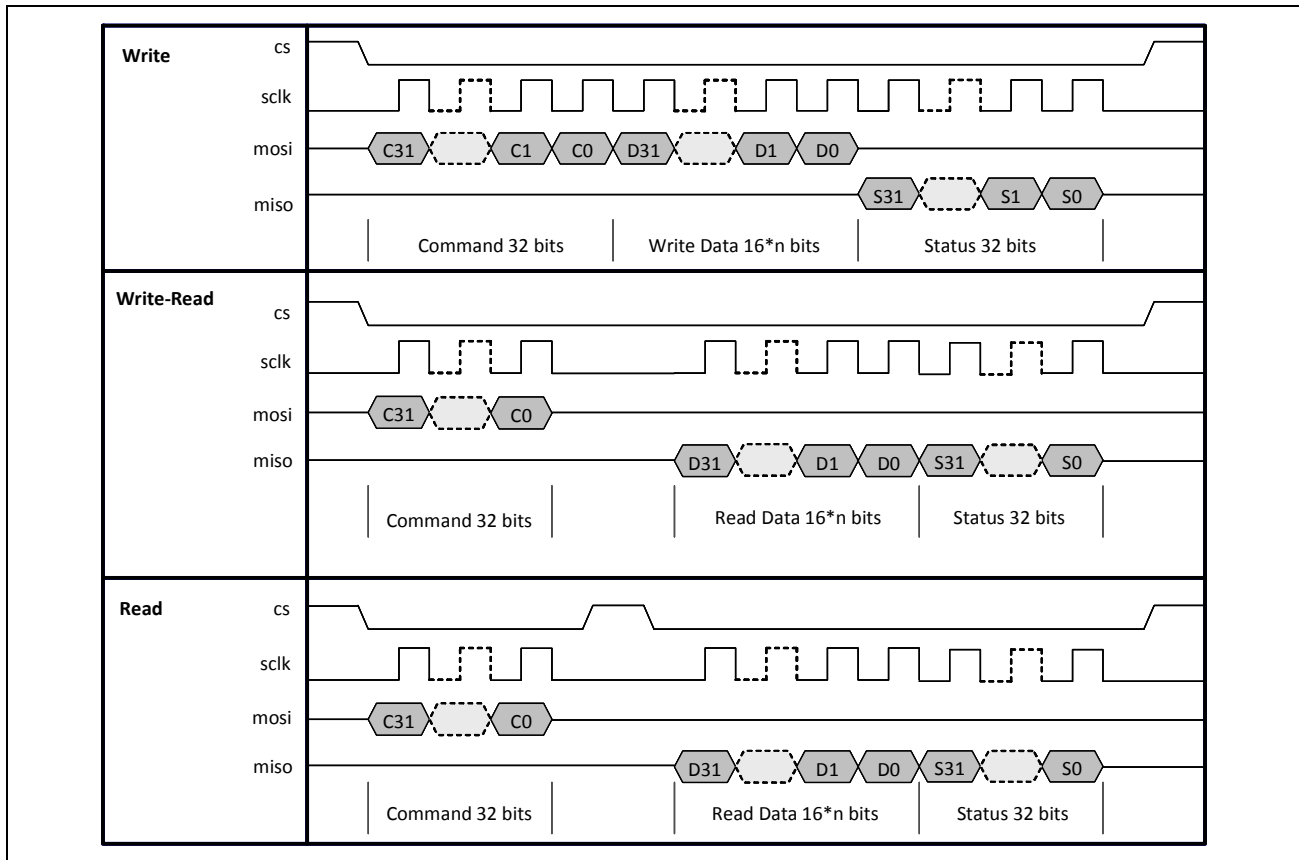

Table 17: gSPI Status Field Details

Bit	Name	Description
0	Data not available	The requested read data is not available
1	Underflow	FIFO underflow occurred due to current (F2, F3) read command
2	Overflow	FIFO overflow occurred due to current (F1, F2, F3) write command
3	F2 interrupt	F2 channel interrupt
4	F3 interrupt	F3 channel interrupt
5	F2 RX Ready	F2 FIFO is ready to receive data (FIFO empty)
6	F3 RX Ready	F3 FIFO is ready to receive data (FIFO empty)
7	Reserved	–
8	F2 Packet Available	Packet is available/ready in F2 TX FIFO
9:19	F2 Packet Length	Length of packet available in F2 FIFO
20	F3 Packet Available	Packet is available/ready in F3 TX FIFO
21:31	F3 Packet Length	Length of packet available in F3 FIFO

gSPI Host-Device Handshake

To initiate communication through the gSPI after power-up, the host needs to bring up the WLAN/Chip by writing to the wake-up WLAN register bit. Writing a 1 to this bit will start up the necessary crystals and PLLs so that the BCM4339 is ready for data transfer. The device can signal an interrupt to the host indicating that the device is awake and ready. This procedure also needs to be followed for waking up the device in sleep mode. The device can interrupt the host using the WLAN IRQ line whenever it has any information to pass to the host. On getting an interrupt, the host needs to read the interrupt and/or status register to determine the cause of interrupt and then take necessary actions.

Boot-Up Sequence

After power-up, the gSPI host needs to wait 150 ms for the device to be out of reset. For this, the host needs to poll with a read command to F0 addr 0x14. Address 0x14 contains a predefined bit pattern. As soon as the host gets a response back with the correct register content, it implies that the device has powered up and is out of reset. After that, the host needs to set the wakeup-WLAN bit (F0 reg 0x00 bit 7). The wakeup-WLAN issues a clock request to the PMU.

For the first time after power-up, the host must wait for the availability of low power clock inside the device. Once that is available, the host must write to a PMU register to set the crystal frequency, which turns on the PLL. After the PLL is locked, the chipActive interrupt is issued to the host. This interrupt indicates the device awake/ready status. See [Table 18](#) for information on gSPI registers.

In [Table 18](#), the following notation is used for register access:

- R: Readable from host and CPU
- W: Writable from host
- U: Writable from CPU

Table 18: gSPI Registers

Address	Register	Bit	Access	Default	Description
x0000	Word length	0	R/W/U	0	0: 16 bit word length 1: 32 bit word length
	Endianness	1	R/W/U	0	0: Little Endian 1: Big Endian
	High-speed mode	4	R/W/U	1	0: Normal mode. RX and TX at different edges. 1: High speed mode. RX and TX on same edge (default).
	Interrupt polarity	5	R/W/U	1	0: Interrupt active polarity is low 1: Interrupt active polarity is high (default)
	Wake-up	7	R/W	0	A write of 1 will denote a wake-up command from the host to the device. This will be followed by an F2 Interrupt from the gSPI device to the host, indicating device awake status.
x0001	Response delay	7:0	R/W/U	8'h04	Configurable read response delay in multiples of 8 bits

Table 18: gSPI Registers (Cont.)

Address	Register	Bit	Access	Default	Description
x0002	Status enable	0	R/W	1	0: no status sent to host after read/write 1: status sent to host after read/write
	Interrupt with status	1	R/W	0	0: do not interrupt if status is sent 1: interrupt host even if status is sent
	Response delay for all	2	R/W	0	0: response delay applicable to F1 read only 1: response delay applicable to all function read
x0003	Reserved	–	–	–	–
x0004	Interrupt register	0	R/W	0	Requested data not available; Cleared by writing a 1 to this location
		1	R	0	F2/F3 FIFO underflow due to last read
		2	R	0	F2/F3 FIFO overflow due to last write
		5	R	0	F2 packet available
		6	R	0	F3 packet available
		7	R	0	F1 overflow due to last write
		x0005	Interrupt register	5	R
6	R			0	F2 Interrupt
7	R			0	F3 Interrupt
x0006– x0007	Interrupt enable register	15:0	R/W/U	16'hE0E7	Particular Interrupt is enabled if a corresponding bit is set
x0008– x000B	Status register	31:0	R	32'h0000	Same as status bit definitions
x000C– x000D	F1 info register	0	R	1	F1 enabled
		1	R	0	F1 ready for data transfer
		13:2	R/U	12'h40	F1 max packet size
x000E– x000F	F2 info register	0	R/U	1	F2 enabled
		1	R	0	F2 ready for data transfer
		15:2	R/U	14'h800	F2 max packet size
x0010– x0011	F3 info register	0	R/U	1	F3 enabled
		1	R	0	F3 ready for data transfer
		15:2	R/U	14'h800	F3 max packet size
x0014– x0017	Test–Read only register	31:0	R	32'hFEE DBEAD	This register contains a predefined pattern, which the host can read and determine if the gSPI interface is working properly.
x0018– x001B	Test–R/W register	31:0	R/W/U	32'h0000 0000	This is a dummy register where the host can write some pattern and read it back to determine if the gSPI interface is working properly.

Figure 33 shows the WLAN boot-up sequence from power-up to firmware download.

Figure 33: WLAN Boot-Up Sequence

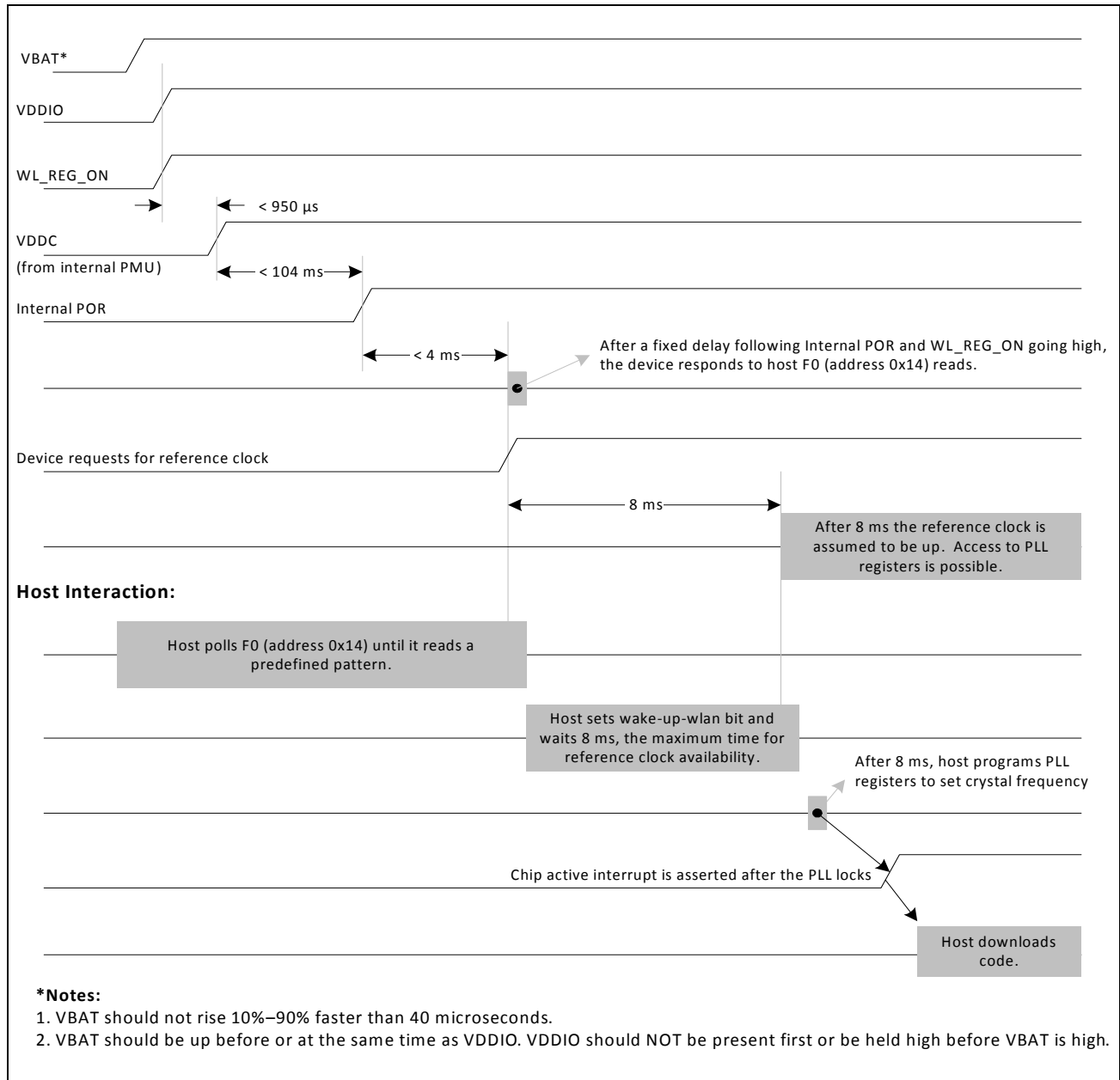

PCI Express Interface (FCBGA Package Only)

The PCI Express (PCIe™) core on the BCM4339 is a high-performance serial I/O interconnect that is protocol compliant and electrically compatible with the *PCI Express Base Specification* (revision 3.0 compliant Gen1 interface). This core contains all the necessary blocks, including logical and electrical subblocks to perform PCIe functionality and maintain high-speed links, using existing PCI system configuration software implementations without modification.

Organization of the PCIe core is in logical layers: Transaction Layer, Data Link Layer, and Physical Layer, as shown in Figure 34. A configuration or link management block is provided for enumerating the PCIe configuration space and supporting generation and reception of System Management Messages by communicating with PCIe layers.

Each layer is partitioned into dedicated transmit and receive units that allow point-to-point communication between the host and BCM4339 device. The transmit side processes outbound packets while the receive side processes inbound packets. Packets are formed and generated in the Transaction and Data Link Layer for transmission onto the high-speed links and onto the receiving device. A header is added at the beginning to indicate the packet type and any other optional fields.

Figure 34: PCI Express Layer Model

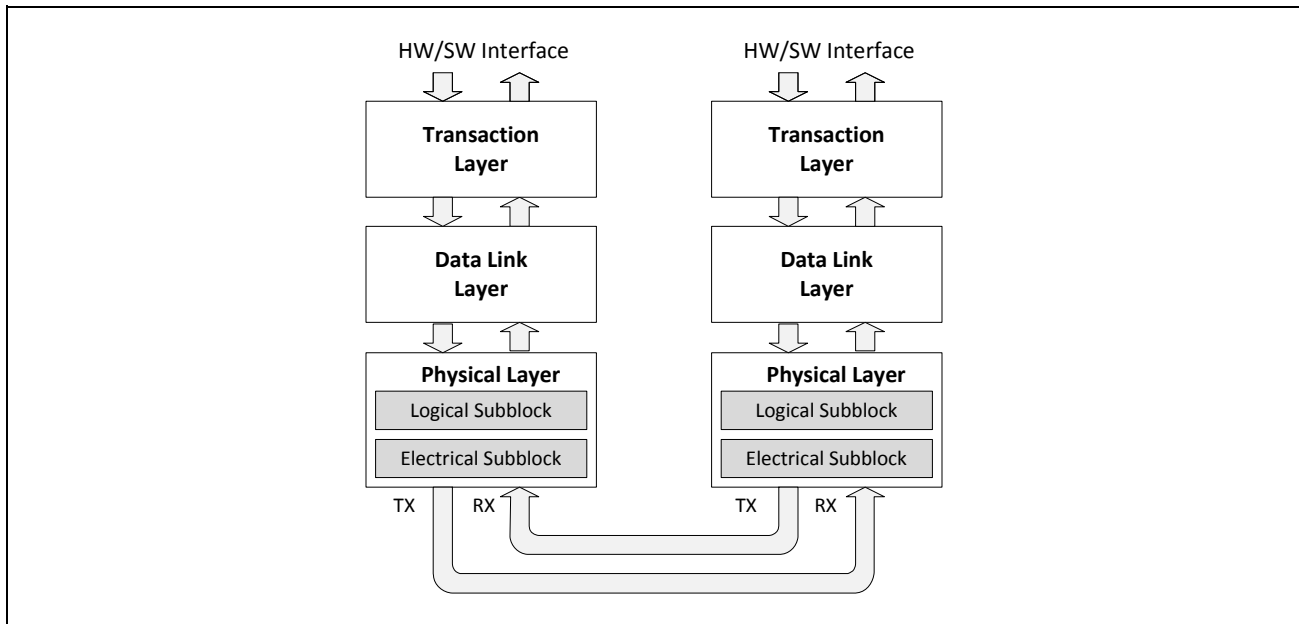

Transaction Layer Interface

The PCIe core employs a packet-based protocol to transfer data between the host and BCM4339 device, delivering new levels of performance and features. The upper layer of the PCIe is the Transaction Layer. The Transaction layer is primarily responsible for assembly and disassembly of Transaction Layer Packets (TLPs). TLP structure contains header, data payload, and End-to-End CRC (ECRC) fields, which are used to communicate transactions, such as read and write requests and other events.

A pipelined full split-transaction protocol is implemented in this layer to maximize efficient communication between devices with credit-based flow control of TLP, which eliminates wasted link bandwidth due to retries.

Data Link Layer

The data link layer serves as an intermediate stage between the transaction layer and the physical layer. Its primary responsibility is to provide reliable, efficient mechanism for the exchange of TLPs between two directly connected components on the link. Services provided by the data link layer include data exchange, initialization, error detection and correction, and retry services.

Data Link Layer Packets (DLLPs) are generated and consumed by the data link layer. DLLPs are the mechanism used to transfer link management information between data link layers of the two directly connected components on the link, including TLP acknowledgement, power management, and flow control.

Physical Layer

The physical layer of the PCIe provides a handshake mechanism between the data link layer and the high-speed signaling used for Link data interchange. This layer is divided into the logical and electrical functional subblocks. Both subblocks have dedicated transmit and receive units that allow for point-to-point communication between the host and BCM4339 device. The transmit section prepares outgoing information passed from the data link layer for transmission, and the receiver section identifies and prepares received information before passing it to the data link layer. This process involves link initialization, configuration, scrambler, and data conversion into a specific format.

Logical Subblock

The logical sub block primary functions are to prepare outgoing data from the data link layer for transmission and identify received data before passing it to the data link layer.

Scrambler/Descrambler

This PCIe PHY component generates pseudo-random sequence for scrambling of data bytes and the idle sequence. On the transmit side, scrambling is applied to characters prior to the 8b/10b encoding. On the receive side, descrambling is applied to characters after 8b/10b decoding. Scrambling may be disabled in polling and recovery for testing and debugging purposes.

8B/10B Encoder/Decoder

The PCIe core on the BCM4339 uses an 8b/10b encoder/decoder scheme to provide DC balancing, synchronizing clock and data recovery, and error detection. The transmission code is specified in the ANSI X3.230-1994, clause 11 and in IEEE 802.3z, 36.2.4.

Using this scheme, 8-bit data characters are treated as 3 bits and 5 bits mapped onto a 4-bit code group and a 6-bit code group, respectively. The control bit in conjunction with the data character is used to identify when to encode one of the twelve Special Symbols included in the 8b/10b transmission code. These code groups are concatenated to form a 10-bit symbol, which is then transmitted serially. Special Symbols are used for link management, frame TLPs, and DLLPs, allowing these packets to be quickly identified and easily distinguished.

Elastic FIFO

An elastic FIFO is implemented in the receiver side to compensate for the differences between the transmit clock domain and the receive clock domain, with worst case clock frequency specified at 600 ppm tolerance. As a result, the transmit and receive clocks can shift one clock every 1666 clocks. In addition, the FIFO adaptively adjusts the elastic level based on the relative frequency difference of the write and read clock. This technique reduces the elastic FIFO size and the average receiver latency by half.

Electrical Subblock

The high-speed signals utilize the Common Mode Logic (CML) signaling interface with on-chip termination and de-emphasis for best-in-class signal integrity. A de-emphasis technique is employed to reduce the effects of Intersymbol Interference (ISI) due to the interconnect by optimizing voltage and timing margins for worst case channel loss. This results in a maximally open “eye” at the detection point, thereby allowing the receiver to receive data with acceptable Bit-Error Rate (BER).

To further minimize ISI, multiple bits of the same polarity that are output in succession are de-emphasized. Subsequent same bits are reduced by a factor of 3.5 dB in power. This amount is specified by PCIe to allow for maximum interoperability while minimizing the complexity of controlling the de-emphasis values. The high-speed interface requires AC coupling on the transmit side to eliminate the DC common mode voltage from the receiver. The range of AC capacitance allowed is 75 nF to 200 nF.

Configuration Space

The PCIe function in the BCM4339 implements the configuration space as defined in the *PCI Express Base Specification* (revision 3.0 compliant Gen1 interface).

Section 11: Wireless LAN MAC and PHY

IEEE 802.11ac MAC

The BCM4339 WLAN MAC is designed to support high-throughput operation with low-power consumption. It does so without compromising the Bluetooth coexistence policies, thereby enabling optimal performance over both networks. In addition, several power saving modes have been implemented that allow the MAC to consume very little power while maintaining network-wide timing synchronization. The architecture diagram of the MAC is shown in [Figure 35](#).

The following sections provide an overview of the important modules in the MAC.

Figure 35: WLAN MAC Architecture

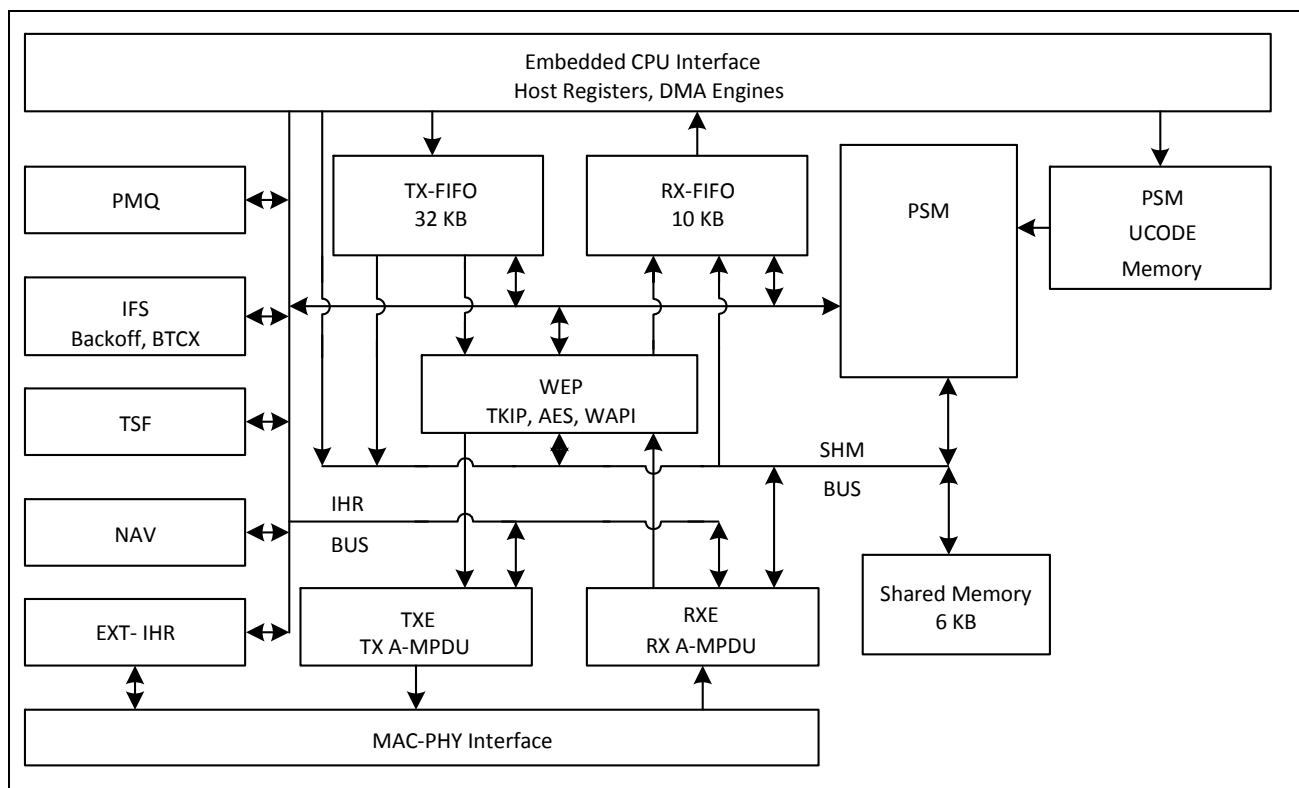

The BCM4339 WLAN media access controller (MAC) supports features specified in the IEEE 802.11 base standard, and amended by IEEE 802.11n. The key MAC features include:

- Enhanced MAC for supporting IEEE 802.11ac features
- Transmission and reception of aggregated MPDUs (A-MPDU) for high throughput (HT)
- Support for power management schemes, including WMM power-save, power-save multi-poll (PSMP) and multiphase PSMP operation
- Support for immediate ACK and Block-ACK policies

- Interframe space timing support, including RIFS
- Support for RTS/CTS and CTS-to-self frame sequences for protecting frame exchanges
- Back-off counters in hardware for supporting multiple priorities as specified in the WMM specification
- Timing synchronization function (TSF), network allocation vector (NAV) maintenance, and target beacon transmission time (TBTT) generation in hardware
- Hardware offload for AES-CCMP, legacy WPA TKIP, legacy WEP ciphers, WAPI, and support for key management
- Support for coexistence with Bluetooth and other external radios
- Programmable independent basic service set (IBSS) or infrastructure basic service set functionality
- Statistics counters for MIB support

PSM

The programmable state machine (PSM) is a micro-coded engine, which provides most of the low-level control to the hardware, to implement the IEEE 802.11 specification. It is a microcontroller that is highly optimized for flow control operations, which are predominant in implementations of communication protocols. The instruction set and fundamental operations are simple and general, which allows algorithms to be optimized until very late in the design process. It also allows for changes to the algorithms to track evolving IEEE 802.11 specifications.

The PSM fetches instructions from the microcode memory. It uses the shared memory to obtain operands for instructions, as a data store, and to exchange data between both the host and the MAC data pipeline (via the SHM bus). The PSM also uses a scratch-pad memory (similar to a register bank) to store frequently accessed and temporary variables.

The PSM exercises fine-grained control over the hardware engines, by programming internal hardware registers (IHR). These IHRs are co-located with the hardware functions they control, and are accessed by the PSM via the IHR bus.

The PSM fetches instructions from the microcode memory using an address determined by the program counter, instruction literal, or a program stack. For ALU operations the operands are obtained from shared memory, scratch-pad, IHRs, or instruction literals, and the results are written into the shared memory, scratch-pad, or IHRs.

There are two basic branch instructions: conditional branches and ALU based branches. To better support the many decision points in the IEEE 802.11 algorithms, branches can depend on either a readily available signals from the hardware modules (branch condition signals are available to the PSM without polling the IHRs), or on the results of ALU operations.

WEP

The wired equivalent privacy (WEP) engine encapsulates all the hardware accelerators to perform the encryption and decryption, and MIC computation and verification. The accelerators implement the following cipher algorithms: legacy WEP, WPA TKIP, WPA2 AES-CCMP.

The PSM determines, based on the frame type and association information, the appropriate cipher algorithm to be used. It supplies the keys to the hardware engines from an on-chip key table. The WEP interfaces with the TXE to encrypt and compute the MIC on transmit frames, and the RXE to decrypt and verify the MIC on receive frames.

TXE

The transmit engine (TXE) constitutes the transmit data path of the MAC. It coordinates the DMA engines to store the transmit frames in the TXFIFO. It interfaces with WEP module to encrypt frames, and transfers the frames across the MAC-PHY interface at the appropriate time determined by the channel access mechanisms.

The data received from the DMA engines are stored in transmit FIFOs. The MAC supports multiple logical queues to support traffic streams that have different QoS priority requirements. The PSM uses the channel access information from the IFS module to schedule a queue from which the next frame is transmitted. Once the frame is scheduled, the TXE hardware transmits the frame based on a precise timing trigger received from the IFS module.

The TXE module also contains the hardware that allows the rapid assembly of MPDUs into an A-MPDU for transmission. The hardware module aggregates the encrypted MPDUs by adding appropriate headers and pad delimiters as needed.

RXE

The receive engine (RXE) constitutes the receive data path of the MAC. It interfaces with the DMA engine to drain the received frames from the RXFIFO. It transfers bytes across the MAC-PHY interface and interfaces with the WEP module to decrypt frames. The decrypted data is stored in the RXFIFO.

The RXE module contains programmable filters that are programmed by the PSM to accept or filter frames based on several criteria such as receiver address, BSSID, and certain frame types.

The RXE module also contains the hardware required to detect A-MPDUs, parse the headers of the containers, and disaggregate them into component MPDUS.

IFS

The IFS module contains the timers required to determine interframe space timing including RIFS timing. It also contains multiple backoff engines required to support prioritized access to the medium as specified by WMM.

The interframe spacing timers are triggered by the cessation of channel activity on the medium, as indicated by the PHY. These timers provide precise timing to the TXE to begin frame transmission. The TXE uses this information to send response frames or perform transmit frame-bursting (RIFS or SIFS separated, as within a TXOP).

The backoff engines (for each access category) monitor channel activity, in each slot duration, to determine whether to continue or pause the backoff counters. When the backoff counters reach 0, the TXE gets notified, so that it may commence frame transmission. In the event of multiple backoff counters decrementing to 0 at the same time, the hardware resolves the conflict based on policies provided by the PSM.

The IFS module also incorporates hardware that allows the MAC to enter a low-power state when operating under the IEEE power save mode. In this mode, the MAC is in a suspended state with its clock turned off. A sleep timer, whose count value is initialized by the PSM, runs on a slow clock and determines the duration over which the MAC remains in this suspended state. Once the timer expires the MAC is restored to its functional state. The PSM updates the TSF timer based on the sleep duration ensuring that the TSF is synchronized to the network.

The IFS module also contains the PTA hardware that assists the PSM in Bluetooth coexistence functions.

TSF

The timing synchronization function (TSF) module maintains the TSF timer of the MAC. It also maintains the target beacon transmission time (TBTT). The TSF timer hardware, under the control of the PSM, is capable of adopting timestamps received from beacon and probe response frames in order to maintain synchronization with the network.

The TSF module also generates trigger signals for events that are specified as offsets from the TSF timer, such as uplink and downlink transmission times used in PSMP.

NAV

The network allocation vector (NAV) timer module is responsible for maintaining the NAV information conveyed through the duration field of MAC frames. This ensures that the MAC complies with the protection mechanisms specified in the standard.

The hardware, under the control of the PSM, maintains the NAV timer and updates the timer appropriately based on received frames. This timing information is provided to the IFS module, which uses it as a virtual carrier-sense indication.

MAC-PHY Interface

The MAC-PHY interface consists of a data path interface to exchange RX/TX data from/to the PHY. In addition, there is an programming interface, which can be controlled either by the host or the PSM to configure and control the PHY.

IEEE 802.11ac PHY

The BCM4339 WLAN Digital PHY is designed to comply with IEEE 802.11ac and IEEE 802.11a/b/g/n single-stream specifications to provide wireless LAN connectivity supporting data rates from 1 Mbps to 433.3 Mbps for low-power, high-performance handheld applications.

The PHY has been designed to work in the presence of interference, radio nonlinearity, and various other impairments. It incorporates optimized implementations of the filters, FFT and Viterbi decoder algorithms. Efficient algorithms have been designed to achieve maximum throughput and reliability, including algorithms for carrier sense/rejection, frequency/phase/timing acquisition and tracking, channel estimation and tracking. The PHY receiver also contains a robust IEEE 802.11b demodulator. The PHY carrier sense has been tuned to provide high throughput for IEEE 802.11g/11b hybrid networks with Bluetooth coexistence. It has also been designed for shared single antenna systems between WL and BT to support simultaneous RX-RX.

The key PHY features include:

- Programmable data rates from MCS0–9 in 20 MHz, 40 MHz, and 80 MHz channels, as specified in IEEE 802.11ac
- Supports Optional Short GI mode in TX and RX
- TX and RX LDPC for improved range and power efficiency
- Supports optional space-time block code (STBC) receive of two space-time streams for improved throughput and range in fading channel environments.
- All scrambling, encoding, forward error correction, and modulation in the transmit direction and inverse operations in the receive direction.
- Supports IEEE 802.11h/k for worldwide operation
- Advanced algorithms for low power, enhanced sensitivity, range, and reliability
- Algorithms to improve performance in presence of Bluetooth
- Automatic gain control scheme for blocking and non blocking application scenario for cellular applications
- Closed loop transmit power control
- Digital RF chip calibration algorithms to handle CMOS RF chip non-idealities
- On-the-fly channel frequency and transmit power selection
- Supports per packet RX antenna diversity
- Available per-packet channel quality and signal strength measurements
- Designed to meet FCC and other worldwide regulatory requirements

Figure 36: WLAN PHY Block Diagram

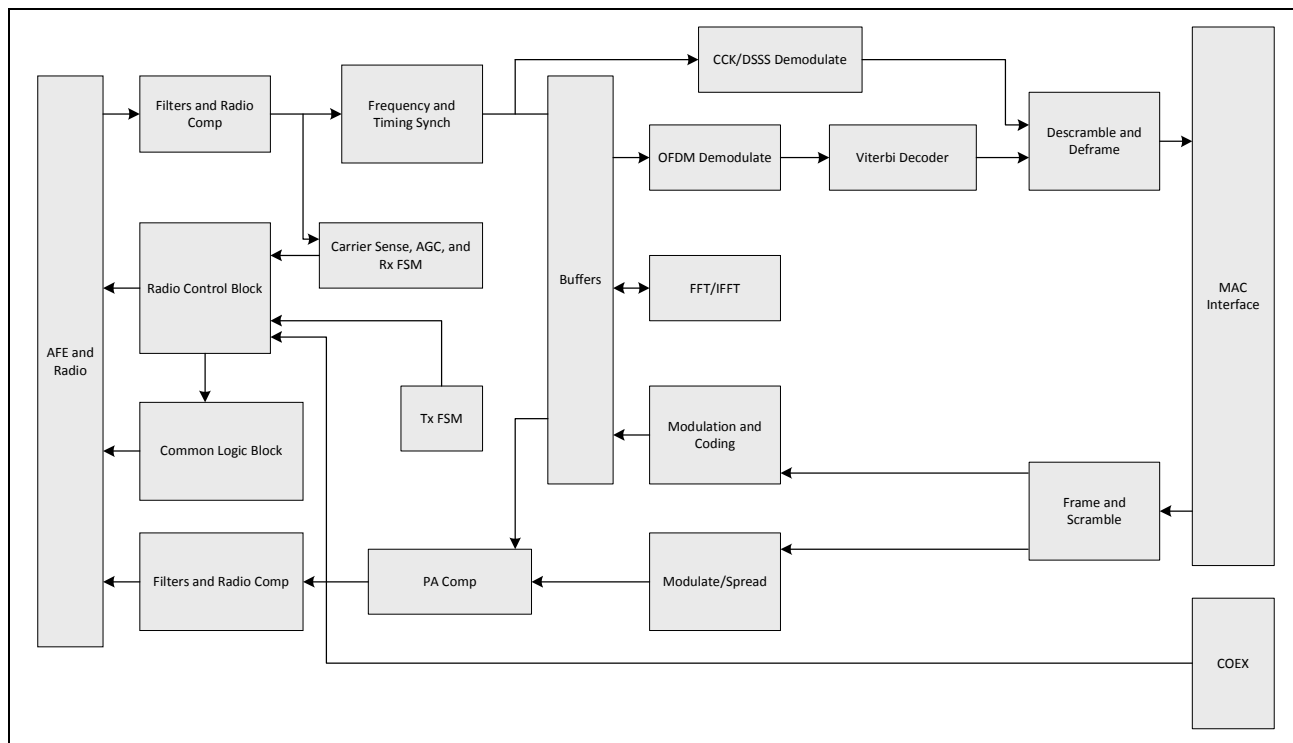

Section 12: WLAN Radio Subsystem

The BCM4339 includes an integrated dual-band WLAN RF transceiver that has been optimized for use in 2.4 GHz and 5 GHz Wireless LAN systems. It has been designed to provide low-power, low-cost, and robust communications for applications operating in the globally available 2.4 GHz unlicensed ISM or 5 GHz U-NII bands. The transmit and receive sections include all on-chip filtering, mixing, and gain control functions.

Ten RF control signals are available to drive external RF switches and support optional external power amplifiers and low-noise amplifiers for each band. See the reference board schematics for further details.

A block diagram of the radio subsystem is shown in [Figure 37 on page 93](#). Note that integrated on-chip baluns (not shown) convert the fully differential transmit and receive paths to single-ended signal pins.

Receiver Path

The BCM4339 has a wide dynamic range, direct conversion receiver that employs high order on-chip channel filtering to ensure reliable operation in the noisy 2.4 GHz ISM band or the entire 5 GHz U-NII band. An on-chip low-noise amplifier (LNA) in the 2.4 GHz path is shared between the Bluetooth and WLAN receivers, while the 5 GHz receive path has a dedicated on-chip LNA. Control signals are available that can support the use of optional LNAs for each band, which can increase the receive sensitivity by several dB.

Transmit Path

Baseband data is modulated and upconverted to the 2.4 GHz ISM or 5-GHz U-NII bands, respectively. Linear on-chip power amplifiers are included, which are capable of delivering high output powers while meeting IEEE 802.11ac and IEEE 802.11a/b/g/n specifications without the need for external PAs. When using the internal PAs, closed-loop output power control is completely integrated. As an option, external PAs can be used for even higher output power, in which case the closed-loop output power control is provided by means of a-band and g-band TSSI inputs from external power detectors.

Calibration

The BCM4339 features dynamic and automatic on-chip calibration to continually compensate for temperature and process variations across components. These calibration routines are performed periodically in the course of normal radio operation. Examples of some of the automatic calibration algorithms are baseband filter calibration for optimum transmit and receive performance, and LOFT calibration for carrier leakage reduction. In addition, I/Q Calibration, R Calibration, and VCO Calibration are performed on-chip. No per-board calibration is required in manufacturing test, which helps to minimize the test time and cost in large volume production.

Figure 37: Radio Functional Block Diagram

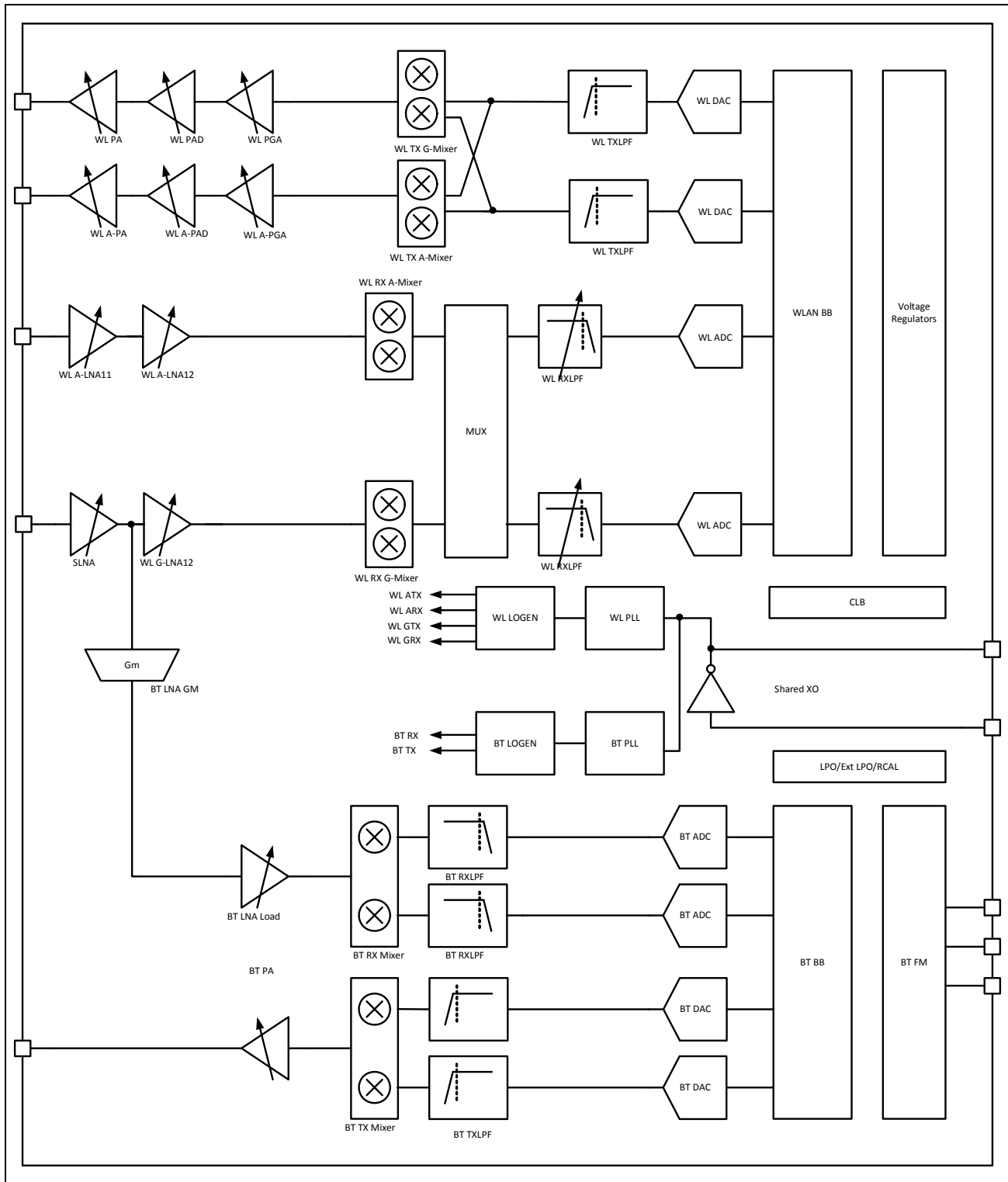

Section 13: Pinout and Signal Descriptions

Ball Maps

Figure 38 shows the FCFBGA ball map. Figure 39 shows the WLPGA ball map. Figure 40 shows the WLCSP bump map.

Figure 38: 160-Ball FCFBGA (Top View)

	1	2	3	4	5	6	7	8	9	10	11	12	13	14	15	16	17	18	19		
A		SR_VLX	GPIO_13		GPIO_5		GPIO_3		VDDIO_SD		SDIO_DATA_1							PAD_REFCLKN	PCIE_CLKREQ_L	A	
B	SR_VDDBATPSV	SR_VLX	VDDIO		GPIO_4		GPIO_7		SDIO_DATA_3		SDIO_CLK		PAD_RDN0	PAD_TDP0	PAD_TDN0	PERST_L		PAD_REFCLKP	PCI_PME_1	B	
C	SR_VDDBATPSV	SR_VDDBATPSV	SR_VDDBATASV	BT_REG_ON	JTAG_SEL	GPIO_6	GPIO_2	SDIO_DATA_2	SDIO_DATA_0	SDIO_CMD			PAD_RDP0			GPIO_1			BT_GPIO_4	C	
D	SR_PVSS			WL_REG_ON	GPIO_15		GPIO_14	GPIO_0					PCIE_VSS			PCIE_VSS		PAD_PLL_AVDD1P2	PAD_AVDD1P2	D	
E	SR_PVSS	SR_PVSS					GPIO_8		VDDC	VDDC										E	
F	LDO_VDD1P5	LDO_VDD1P5		NO CONNECT																F	
G		VOUT_CLDO		NO CONNECT									VDDC			RF_SW_CTRL_8	RF_SW_CTRL_5	RF_SW_CTRL_6	RF_SW_CTRL_3	G	
H	VOUT_3P3	VOUT_3P3_SENSE					PMU_AVSS	VSSC	VSSC	VSSC	VSSC		VDDC			RF_SW_CTRL_9	RF_SW_CTRL_4			H	
J		VOUT_BTLD02P5				LPO_IN	VSSC					VSSC				RF_SW_CTRL_7	RF_SW_CTRL_1	RF_SW_CTRL_2	RF_SW_CTRL_0	J	
K		VOUT_LNLD0				VDDC	VSSC					VSSC					VDDIO_RF			K	
L	LDO_VDDBATSV	PMU_VDDIO	BT_VDDIO			BT_VDDC	VSSC	VSSC	VSSC	WRF_VCO_GND1P2	BBPLLAVSS				WRF_BUCK_VDD1P5			OTP_VDD33	BBPLLAVDD	L	
M			BT_DEV_WAKE			BT_VDDC	VSSC	VSSC	VSSC	WRF_LOGENG_GND1P2	WRF_BUCK_GND1P5				WRF_XTAL_GND1P2					M	
N	HUSB_DN	HUSB_DP	BT_SF_MOSI												WRF_CP_GND1P2				WRF_XTAL_VDD1P5	N	
P			BT_SF_CLK			BT_VCOVSS				WRF_RX2G_GND1P2			WRF_MMD_GND1P2	WRF_PFD_GND1P2				WRF_XTAL_GND1P2	WRF_XTAL_IN	P	
R	BT_SF_CSN	BT_SF_MISO	BT_I2S_CLK			BT_PLLVSS	BT_LNAVSS	BT_IFVSS		WRF_PA2G_VBAT_GND3P3	WRF_AFE_GND1P2	WRF_TX_GND1P2	WRF_PADRV_VBAT_GND3P3	WRF_LOGEN_GND1P2					WRF_XTAL_OUT	R	
T			BT_UART_CTS_N				BT_PAVSS		WRF_LNA_2G_GND1P2						WRF_LNA_5G_GND1P2	WRF_RX5G_GND1P2		WRF_PFD_VDD1P2	WRF_XTAL_VDD1P2	T	
U	BT_I2S_WS	BT_I2S_DO	BT_I2S_DI												WRF_PASG_VBAT_GND3P3				WRF_MMD_VDD1P2	U	
V	BT_UART_RTS_N		BT_HOST_WAKE	BT_VCOVDD	BT_PLLVDD		BT_PAVDD		WRF_GPIO_OUT	WRF_TSSLA	WRF_PA2G_VBAT_GND3P3	WRF_PA2G_VBAT_VDD3P3	WRF_PADRV_VBAT_VDD3P3	WRF_PASG_VBAT_VDD3P3	WRF_PASG_VBAT_GND3P3	WRF_PASG_VBAT_GND3P3			WRF_SYNTH_VBAT_VDD3P3	V	
W	BT_UART_RXD	BT_UART_TXD	CLK_REQ		BT_LNAVDD	BT_IFVDD	BT_RF		WRF_RFIN_2G			WRF_RFOUT_2G					WRF_RFOUT_5G		WRF_RFIN_5G	NO CONNECT	W

Figure 39: 145-Ball WLBGA (Top View)

	1	2	3	4	5	6	7	8	9	10	11	12	
A		NO CONNECT	NO CONNECT	NO CONNECT		NO CONNECT	NO CONNECT		NO CONNECT	NO CONNECT	NO CONNECT		A
B	SR_PVSS	SR_VLX	WL_REG_ON	LPO_IN	GPIO_3	GPIO_0	HSIC_DATA	HSIC_STROBE	RREFHSIC	SDIO_DATA_0	SDIO_CLK	SDIO_CMD	B
C	SR_VDDBATP5V	SR_VDDBATA5V	PMU_AVSS	GPIO_6	GPIO_4	GPIO_1	WL_VDDC	HSIC_AVDD12PLL	HSIC_DVDD12	SDIO_DATA_1	SDIO_DATA_3	WL_VDDC	C
D	LDO_VDD1P5	VOUT_CLDO	BT_REG_ON	GPIO_7	GPIO_5	GPIO_2	VSSC	HSIC_AGNDPLL	VDDIO_SD	SDIO_DATA_2	VSSC	RF_SW_CTRL_4	D
E	VOUT_3P3	VOUT_LNLDO	VSSC		JTAG_SEL	BT_UART_CTS	VDDIO_RF	VSSC		RF_SW_CTRL_8	RF_SW_CTRL_3	RF_SW_CTRL_2	E
F	VOUT_BTLD02P5	LDO_VDDBAT5V	VDDIO		RF_SW_CTRL_9	BT_UART_RTS	BT_UART_TXD	RF_SW_CTRL_5			RF_SW_CTRL_1	RF_SW_CTRL_0	F
G	BT_PCM_IN	BT_PCM_CLK		WL_VDDC	WL_VDDC	BT_UART_RXD	RF_SW_CTRL_7	WL_VDDC		BBPLL_AV5	WRF_XTAL_GND1P2	BBPLL_AVDD1P2	G
H	GPIO_8	BT_PCM_SYNC	CLK_REQ	BT_VDDIO	BT_VDDC	BT_I2S_WS	WRF_GPIO_OUT	WRF_WL_LNLDOIN_VDD1P5	RF_SW_CTRL_6	WRF_VCO_GND	WRF_XTAL_VDD1P5	WRF_XTAL_IN	H
J	FM_AUDIOVDD1P2	BT_HOST_WAKE	BT_PCM_OUT	BT_VDDC	VSSC	BT_I2S_CLK	WRF_TSSI_A	WRF_BUCK_GND1P5	WRF_MMD_GND1P2	WRF_PFD_GND1P2	WRF_CP_GND	WRF_XTAL_OUT	J
K	FM_AOUT1	FM_AUDIOVSS	BT_DEV_WAKE	VSSC	BT_I2S_DI	BT_I2S_DO	WRF_AFE_GND1P2	WRF_LO_GND1P2_2	WRF_SYNTH_VBAT_VDD3P3	WRF_MMD_VDD1P2	WRF_PFD_VDD1P2	WRF_XTAL_VDD1P2	K
L	FM_AOUT2	FM_PLLVDD1P2	FM_PLLVSS	BT_IFVDD1P2	BT_PLLVSS	BT_IFVSS	WRF_RX2G_GND1P2	WRF_TX_GND1P2	WRF_PADRV_VBAT_VDD3P3	WRF_PADRV_VBAT_GND3P3	WRF_LO_GND1P2_2	WRF_RX5G_GND1P2	L
M	FM_VCOVSS	FM_LNAVSS	BT_VCOVSS	BT_PLLVDD1P2	BT_PAVSS	BT_AGPIO	WRF_LNA_2G_GND1P2	WRF_PA_VBAT_GND3P3_4	WRF_PA_VBAT_GND3P3_3	WRF_PA_VBAT_GND3P3_2	WRF_PA_VBAT_GND3P3_1	WRF_LNA_5G_GND1P2	M
N	FM_LNAVCOVDD1P2	FM_RFIN	BT_VCOVDD1P2	BT_LNAVDD1P2	BT_RF	BT_PAVDD2P5	WRF_RFIN_2G	WRF_RFOUT_2G	WRF_PA2G_VBAT_VDD3P3	WRF_PA5G_VBAT_VDD3P3	WRF_RFOUT_5G	WRF_RFIN_5G	N
	1	2	3	4	5	6	7	8	9	10	11	12	

Figure 40: 286-Bump WLCSP (Bottom View)

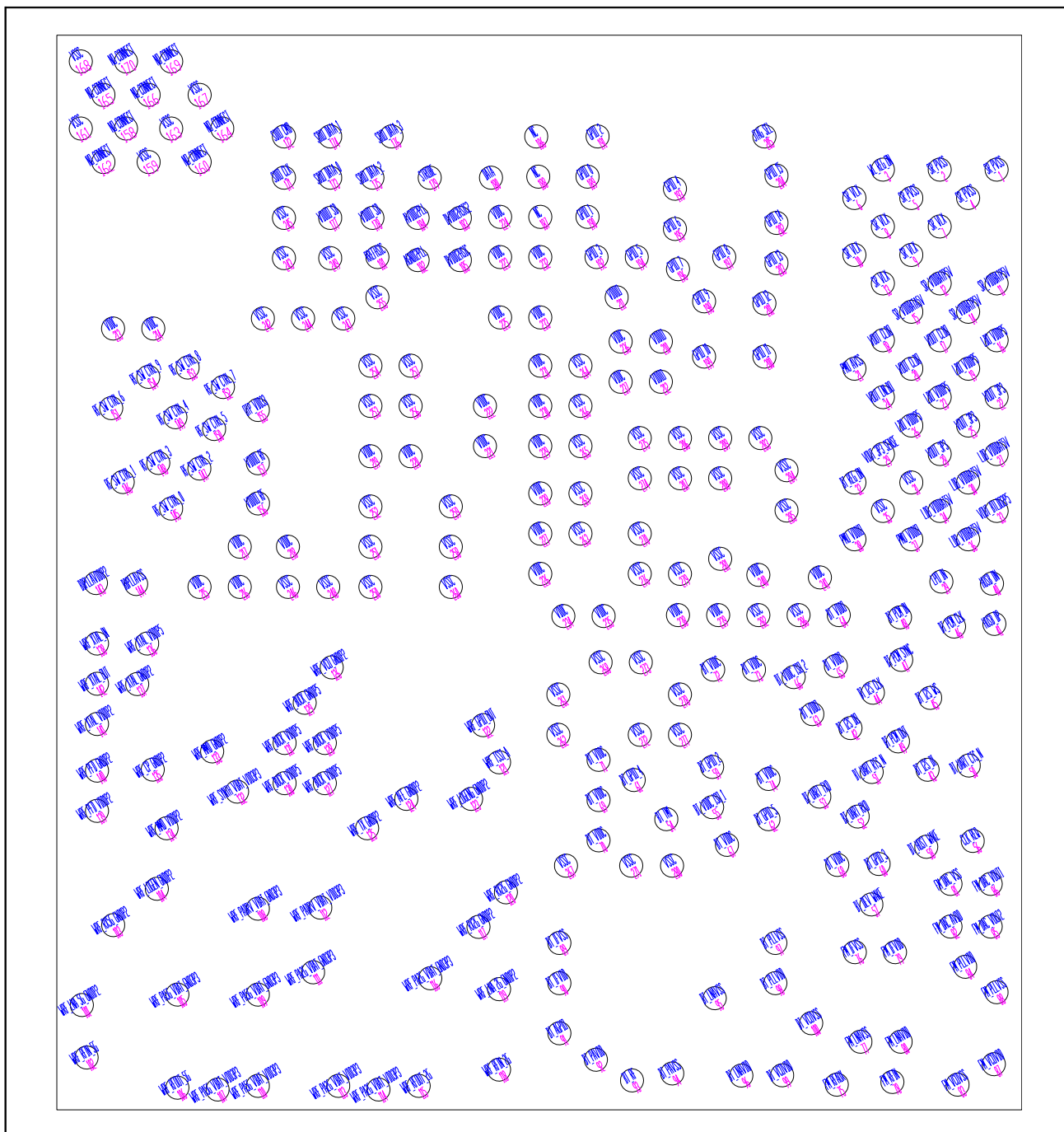

Pin Lists

Table 19 contains the 286-bump WLCSP coordinates.

Table 19: 286-Bump WLCSP Coordinates

Bump#	Signal Name	Package Bump Side View (0,0 center of die)		Package Top Side View (0,0 center of die)	
		X	Y	X	Y
1	SR_PVSS	2275.005	2003.355	-2275.005	2003.355
2	SR_PVSS	1992.162	2003.355	-1992.162	2003.355
3	WL_REG_ON	1709.319	2003.355	-1709.319	2003.355
4	SR_PVSS	2133.584	1861.934	-2133.584	1861.934
5	SR_PVSS	1850.741	1861.934	-1850.741	1861.934
6	SR_VLX	1567.898	1861.934	-1567.898	1861.934
7	SR_VLX	1992.162	1720.512	-1992.162	1720.512
8	SR_VLX	1709.319	1720.512	-1709.319	1720.512
9	SR_VLX	1850.741	1579.091	-1850.741	1579.091
10	SR_VLX	1567.898	1579.091	-1567.898	1579.091
11	SR_VDDBATP5V	2275.005	1437.669	-2275.005	1437.669
12	SR_VDDBATP5V	1992.162	1437.669	-1992.162	1437.669
13	SR_VLX	1709.319	1437.669	-1709.319	1437.669
14	SR_VDDBATP5V	2133.584	1296.248	-2133.584	1296.248
15	SR_VDDBATA5V	1850.741	1296.248	-1850.741	1296.248
16	LDO_VDD1P5	2275.005	1154.826	-2275.005	1154.826
17	VOUT_CLDO	1992.162	1154.826	-1992.162	1154.826
18	VOUT_CLDO	1709.319	1154.826	-1709.319	1154.826
19	LDO_VDD1P5	2133.584	1013.405	-2133.584	1013.405
20	VOUT_CLDO	1850.741	1013.405	-1850.741	1013.405
21	PMU_AVSS	1567.898	1013.405	-1567.898	1013.405
22	VOUT_3P3	2275.005	871.983	-2275.005	871.983
23	LDO_VDD1P5	1992.162	871.983	-1992.162	871.983
24	VOUT_LNLDO	1709.319	871.983	-1709.319	871.983
25	VOUT_3P3	2133.584	730.562	-2133.584	730.562
26	LDO_VDD1P5	1850.741	730.562	-1850.741	730.562
27	LDO_VDDBAT5V	2275.005	589.140	-2275.005	589.140
28	VOUT_3P3	1992.162	589.140	-1992.162	589.140
29	VOUT_3P3_SENSE	1709.319	589.140	-1709.319	589.140
30	LDO_VDDBAT5V	2133.584	447.719	-2133.584	447.719
31	VSSC	1850.741	447.719	-1850.741	447.719
32	BT_REG_ON	1567.898	447.719	-1567.898	447.719
33	VOUT_BTLD02P5	2275.005	306.297	-2275.005	306.297

Table 19: 286-Bump WLCSP Coordinates (Cont.)

Bump#	Signal Name	Package Bump Side View (0,0 center of die)		Package Top Side View (0,0 center of die)	
		X	Y	X	Y
34	LDO_VDDBAT5V	1992.162	306.297	-1992.162	306.297
35	VSSC	1709.319	306.297	-1709.319	306.297
36	LDO_VDDBAT5V	2133.584	164.876	-2133.584	164.876
37	PMU_VDDIO	1850.741	164.876	-1850.741	164.876
38	PMU_VDDIO	1567.898	164.876	-1567.898	164.876
39	LPO_IN	2000.397	-45.054	-2000.397	-45.054
40	HUSB_DN	2252.010	-55.251	-2252.010	-55.251
41	HUSB_DP	2264.169	-255.429	-2264.169	-255.429
42	BT_I2S_DO	1548.201	-773.253	-1548.201	-773.253
43	BT_I2S_DI	1931.412	-980.847	-1931.412	-980.847
44	BT_I2S_CLK	1659.396	-597.546	-1659.396	-597.546
45	BT_I2S_WS	1944.471	-623.367	-1944.471	-623.367
46	BT_PCM_CLK	2063.397	-268.848	-2063.397	-268.848
47	BT_PCM_SYNC	1800.498	-434.448	-1800.498	-434.448
48	BT_PCM_IN	1794.801	-223.146	-1794.801	-223.146
49	BT_PCM_OUT	1784.397	-839.853	-1784.397	-839.853
50	BT_UART_CTS_N	2136.414	-959.733	-2136.414	-959.733
51	BT_UART_RTS_N	1653.744	-991.854	-1653.744	-991.854
52	BT_UART_RXD	1583.904	-1213.488	-1583.904	-1213.488
53	BT_UART_TXD	1393.104	-1114.101	-1393.104	-1114.101
54	BT_TM1	632.001	-1226.646	-632.001	-1226.646
55	BT_VDDC_ISO_1	859.998	-1166.652	-859.998	-1166.652
56	CLK_REQ	2156.196	-1334.853	-2156.196	-1334.853
57	BT_DEV_WAKE	1652.097	-1650.546	-1652.097	-1650.546
58	BT_HOST_WAKE	1925.202	-1363.752	-1925.202	-1363.752
59	BT_GPIO_2	859.998	-966.654	-859.998	-966.654
60	BT_GPIO_3	1688.097	-1449.099	-1688.097	-1449.099
61	BT_GPIO_4	470.001	-1031.652	-470.001	-1031.652
62	BT_GPIO_5	1139.997	-1226.646	-1139.997	-1226.646
63	BT_VDDIO	1358.481	-704.151	-1358.481	-704.151
64	BT_VDDIO	1489.998	-211.653	-1489.998	-211.653
65	BT_VDDIO	1475.499	-464.652	-1475.499	-464.652
66	BT_VDDC_ISO_2	1265.574	-519.930	-1265.574	-519.930
67	BT_VDDC	933.699	-1354.050	-933.699	-1354.050
68	BT_VDDC	1482.501	-1453.950	-1482.501	-1453.950
69	BT_VDDC	294.996	-1131.651	-294.996	-1131.651
70	BT_VDDC	294.996	-1331.649	-294.996	-1331.649

Table 19: 286-Bump WLCSP Coordinates (Cont.)

Bump#	Signal Name	Package Bump Side View (0,0 center of die)		Package Top Side View (0,0 center of die)	
		X	Y	X	Y
71	BT_VDDC	294.996	-931.653	-294.996	-931.653
72	BT_VDDC	864.903	-482.949	-864.903	-482.949
73	BT_VDDC	1067.997	-482.949	-1067.997	-482.949
74	BT_VDDC	1139.997	-1026.648	-1139.997	-1026.648
75	FM_RFAUX	1479.864	-2546.550	-1479.864	-2546.550
76	FM_IFVSS	1569.797	-1888.101	-1569.797	-1888.101
77	FM_LNAVSS	1597.593	-2333.169	-1597.593	-2333.169
78	FM_RFIN	1756.686	-2533.167	-1756.686	-2533.167
79	FM_IFVDD	1769.795	-1888.101	-1769.795	-1888.101
80	FM_LNAVDD	1797.591	-2333.169	-1797.591	-2333.169
81	FM_DAC_VSS	2045.451	-1548.549	-2045.451	-1548.549
82	FM_DAC_AVDD	2045.451	-1760.319	-2045.451	-1760.319
83	FM_VCOVSS	2080.781	-2546.550	-2080.781	-2546.550
84	FM_PLLVDD	2118.860	-1960.317	-2118.860	-1960.317
85	FM_DAC_VOUT2	2245.449	-1760.319	-2245.449	-1760.319
86	FM_DAC_VOUT1	2245.449	-1548.549	-2245.449	-1548.549
87	FM_VCOVDD	2261.469	-2444.675	-2261.469	-2444.675
88	FM_PLLVSS	2274.852	-2086.889	-2274.852	-2086.889
89	BT_IFVSS	99.975	-1842.066	-99.975	-1842.066
90	BT_IFVDD	99.975	-2042.064	-99.975	-2042.064
91	BT_AGPIO	99.975	-2291.099	-99.975	-2291.099
92	BT_PAVDD	281.860	-2422.625	-281.860	-2422.625
93	BT_RF	461.505	-2525.544	-461.505	-2525.544
94	BT_PAVSS	661.503	-2491.097	-661.503	-2491.097
95	BT_LNAVSS	873.183	-2116.746	-873.183	-2116.746
96	BT_LNAVDD	1005.281	-2501.330	-1005.281	-2501.330
97	BT_PLLVSS	1174.454	-1842.066	-1174.454	-1842.066
98	BT_PLLVDD	1174.454	-2042.064	-1174.454	-2042.064
99	BT_VCOVDD	1208.352	-2500.155	-1208.352	-2500.155
100	BT_VCOVSS	1352.595	-2240.766	-1352.595	-2240.766
101	WRF_LNA_5G_GND1P2	-2275.490	-2150.537	2275.490	-2150.537
102	WRF_RFIN_5G	-2251.986	-2411.789	2251.986	-2411.789
103	WRF_RX5G_GND1P2	-2119.686	-1753.146	2119.686	-1753.146
104	WRF_LOGEN_GND1P2	-1902.494	-1572.417	1902.494	-1572.417
105	WRF_PA5G_VBAT_GND3P3	-1800.006	-2098.656	1800.006	-2098.656
106	WRF_RFOUT_5G	-1800.006	-2561.652	1800.006	-2561.652
107	WRF_PA5G_VBAT_VDD3P3	-1600.008	-2570.652	1600.008	-2570.652

Table 19: 286-Bump WLCSP Coordinates (Cont.)

Bump#	Signal Name	Package Bump Side View (0,0 center of die)		Package Top Side View (0,0 center of die)	
		X	Y	X	Y
108	WRF_PADRV_VBAT_GND3P3	-1400.010	-1671.660	1400.010	-1671.660
109	WRF_PA5G_VBAT_GND3P3	-1400.010	-2098.656	1400.010	-2098.656
110	WRF_PA5G_VBAT_VDD3P3	-1400.010	-2552.652	1400.010	-2552.652
111	WRF_PA2G_VBAT_GND3P3	-1125.249	-1987.776	1125.249	-1987.776
112	WRF_PADRV_VBAT_VDD3P3	-1089.249	-1666.260	1089.249	-1666.260
113	WRF_PA2G_VBAT_VDD3P3	-1000.014	-2552.652	1000.014	-2552.652
114	WRF_PA2G_VBAT_VDD3P3	-800.016	-2570.652	800.016	-2570.652
115	WRF_RFOUT_2G	-600.018	-2552.652	600.018	-2552.652
116	WRF_PA2G_VBAT_GND3P3	-542.224	-2017.656	542.224	-2017.656
117	WRF_RX2G_GND1P2	-302.509	-1761.939	302.509	-1761.939
118	WRF_RFIN_2G	-200.022	-2471.652	200.022	-2471.652
119	WRF_LNA_2G_GND1P2	-200.022	-2071.656	200.022	-2071.656
120	WRF_RX2G_GND1P2	-165.822	-1590.174	165.822	-1590.174
121	WRF_TSSI_A	-200.022	-943.668	200.022	-943.668
122	WRF_GPIO_OUT	-279.173	-759.168	279.173	-759.168
123	WRF_LOGENG_GND1P2	-338.919	-1125.594	338.919	-1125.594
124	WRF_AFE_GND1P2	-661.308	-1125.594	661.308	-1125.594
125	WRF_TX_GND1P2	-856.014	-1271.664	856.014	-1271.664
126	WRF_VCO_GND1P2	-1032.414	-471.672	1032.414	-471.672
127	WRF_BUCK_VDD1P5	-1066.853	-1047.744	1066.853	-1047.744
128	WRF_BUCK_VDD1P5	-1066.853	-847.746	1066.853	-847.746
129	WRF_BUCK_GND1P5	-1166.852	-647.748	1166.852	-647.748
130	WRF_BUCK_VDD1P5	-1266.851	-1047.744	1266.851	-1047.744
131	WRF_BUCK_VDD1P5	-1266.851	-847.746	1266.851	-847.746
132	WRF_SYNTH_VBAT_VDD3P3	-1503.344	-1089.662	1503.344	-1089.662
133	WRF_MMD_GND1P2	-1627.031	-889.668	1627.031	-889.668
134	WRF_MMD_VDD1P2	-1854.006	-1271.664	1854.006	-1271.664
135	WRF_CP_GND1P2	-1922.892	-980.154	1922.892	-980.154
136	WRF_XTAL_VDD1P5	-1950.522	-353.066	1950.522	-353.066
137	WRF_XTAL_GND1P2	-2000.004	-554.598	2000.004	-554.598
138	WRF_XTAL_IN	-2199.998	-353.066	2199.998	-353.066
139	WRF_PFD_VDD1P2	-2200.002	-1185.062	2200.002	-1185.062
140	WRF_PFD_GND1P2	-2200.002	-985.064	2200.002	-985.064
141	WRF_XTAL_VDD1P2	-2200.002	-753.062	2200.002	-753.062
142	WRF_XTAL_OUT	-2200.002	-553.063	2200.002	-553.063
143	BBPLLAVDD1P2	-2205.429	-52.326	2205.429	-52.326
144	BBPLLAVSS	-2005.431	-57.348	2005.431	-57.348

Table 19: 286-Bump WLCSP Coordinates (Cont.)

Bump#	Signal Name	Package Bump Side View (0,0 center of die)		Package Top Side View (0,0 center of die)	
		X	Y	X	Y
145	RF_SW_CTRL_0	-1831.200	318.141	1831.200	318.141
146	RF_SW_CTRL_1	-2072.022	449.946	2072.022	449.946
147	RF_SW_CTRL_2	-1691.052	517.221	1691.052	517.221
148	RF_SW_CTRL_3	-1895.118	544.410	1895.118	544.410
149	RF_SW_CTRL_4	-1809.960	772.110	1809.960	772.110
150	RF_SW_CTRL_5	-1617.639	713.790	1617.639	713.790
151	RF_SW_CTRL_6	-2129.154	817.452	2129.154	817.452
152	RF_SW_CTRL_7	-1573.278	922.392	1573.278	922.392
153	RF_SW_CTRL_8	-1749.264	1019.259	1749.264	1019.259
154	RF_SW_CTRL_9	-1944.888	972.936	1944.888	972.936
155	OTP_VDD33	-1400.001	808.353	1400.001	808.353
156	VDDIO_RF	-1399.398	343.350	1399.398	343.350
157	VDDIO_RF	-1400.001	543.348	1400.001	543.348
158	NC	-2055.795	2207.556	2055.795	2207.556
159	PAD_PLL_AVDD1P2	-1943.295	2041.056	1943.295	2041.056
160	NC	-1689.455	2041.056	1689.455	2041.056
161	PAD_PLL_AVSS	-2280.795	2207.556	2280.795	2207.556
162	NC	-2168.295	2041.056	2168.295	2041.056
163	PAD_PLL_AVSS	-1830.795	2207.556	1830.795	2207.556
164	NC	-1576.959	2207.556	1576.959	2207.556
165	NC	-2168.295	2374.758	2168.295	2374.758
166	NC	-1943.295	2374.758	1943.295	2374.758
167	PAD_RXTX_AVDD1P2	-1689.455	2374.758	1689.455	2374.758
168	PAD_RXTX_AVSS	-2280.795	2541.258	2280.795	2541.258
169	NC	-1830.795	2541.258	1830.795	2541.258
170	NC	-2055.795	2541.258	2055.795	2541.258
171	SDIO_CLK	-1269.996	1963.350	1269.996	1963.350
172	SDIO_CMD	-1269.996	2168.352	1269.996	2168.352
173	SDIO_DATA_0	-1040.001	1963.350	1040.001	1963.350
174	SDIO_DATA_1	-1040.001	2168.352	1040.001	2168.352
175	SDIO_DATA_2	-830.004	1963.350	830.004	1963.350
176	SDIO_DATA_3	-735.000	2168.352	735.000	2168.352
177	VDDIO_SD	-1040.001	1763.352	1040.001	1763.352
178	VDDIO_SD	-830.004	1763.352	830.004	1763.352
179	STROBE	-545.001	1963.350	545.001	1963.350
180	DATA	-240.000	1963.350	240.000	1963.350
181	RREFHSIC	-805.002	1568.349	805.002	1568.349

Table 19: 286-Bump WLCSP Coordinates (Cont.)

Bump#	Signal Name	Package Bump Side View (0,0 center of die)		Package Top Side View (0,0 center of die)	
		X	Y	X	Y
182	AGND12PLL	-605.004	1553.346	605.004	1553.346
183	DVDD12HSIC2	-394.998	1763.352	394.998	1763.352
184	AVDD12PLL	-605.004	1763.352	605.004	1763.352
185	DVDD12HSIC	-394.998	1553.346	394.998	1553.346
186	NC	-15.000	2168.352	15.000	2168.352
187	NC	4.998	1768.347	-4.998	1768.347
188	NC	-5.001	1968.354	5.001	1968.354
189	GPIO_0	239.997	1968.354	-239.997	1968.354
190	GPIO_1	239.997	1768.347	-239.997	1768.347
191	GPIO_2	290.001	2168.352	-290.001	2168.352
192	GPIO_3	284.997	1568.349	-284.997	1568.349
193	GPIO_4	675.003	1908.351	-675.003	1908.351
194	GPIO_5	485.004	1568.349	-485.004	1568.349
195	GPIO_6	675.003	1708.353	-675.003	1708.353
196	GPIO_7	689.997	1508.346	-689.997	1508.346
197	GPIO_8	920.001	1568.349	-920.001	1568.349
198	GPIO_9	820.002	1348.353	-820.002	1348.353
199	GPIO_10	820.002	1073.349	-820.002	1073.349
200	GPIO_11	1119.999	1073.349	-1119.999	1073.349
201	GPIO_12	1119.999	1338.354	-1119.999	1338.354
202	GPIO_14	1180.002	1738.350	-1180.002	1738.350
203	GPIO_13	1180.002	1538.352	-1180.002	1538.352
204	GPIO_15	1180.002	1973.349	-1180.002	1973.349
205	JTAG_SEL	1119.999	2168.352	-1119.999	2168.352
206	VSSC	699.996	668.349	-699.996	668.349
207	VSSC	699.996	468.351	-699.996	468.351
208	VSSC	900.003	468.351	-900.003	468.351
209	VSSC	900.003	668.349	-900.003	668.349
210	VDDIO	605.001	1148.346	-605.001	1148.346
211	VDDIO	384.996	1368.351	-384.996	1368.351
212	VDDIO	605.001	948.348	-605.001	948.348
213	VDDC_PHY	-2120.001	1213.353	2120.001	1213.353
214	VDDC_PHY	-1920.003	1213.353	1920.003	1213.353
215	VDDC	-1689.999	-71.649	1689.999	-71.649
216	VDDC	-1490.001	-71.649	1490.001	-71.649
217	VDDC_PHY	-1490.001	128.349	1490.001	128.349
218	VDDC_PHY	-1249.998	128.349	1249.998	128.349

Table 19: 286-Bump WLCSP Coordinates (Cont.)

Bump#	Signal Name	Package Bump Side View (0,0 center of die)		Package Top Side View (0,0 center of die)	
		X	Y	X	Y
219	VDDC_PHY	-840.003	578.349	840.003	578.349
220	VDDC_PHY	-639.996	578.349	639.996	578.349
221	VDDC_PHY	-269.997	628.353	269.997	628.353
222	VDDC_PHY	-269.997	828.351	269.997	828.351
223	VDDC	-195.000	1568.349	195.000	1568.349
224	VDDC	-195.000	1768.347	195.000	1768.347
225	VDDC_PHY	-195.000	1268.352	195.000	1268.352
226	VDDC	4.998	-6.651	-4.998	-6.651
227	VDDC_SUBCORE	4.998	193.347	-4.998	193.347
228	VDDC_SUBCORE	4.998	393.354	-4.998	393.354
229	VDDC	4.998	628.353	-4.998	628.353
230	VDDC	4.998	828.351	-4.998	828.351
231	VDDC_SUBCORE	4.998	1028.349	-4.998	1028.349
232	VDDC_SUBCORE	4.998	1568.349	-4.998	1568.349
233	VDDC_SUBCORE	4.998	1268.352	-4.998	1268.352
234	VDDC	120.000	-216.648	-120.000	-216.648
235	VDDC	319.998	-216.648	-319.998	-216.648
236	VDDC	405.003	1148.346	-405.003	1148.346
237	VDDC_SUBCORE	405.003	948.348	-405.003	948.348
238	VDDC	689.997	-211.653	-689.997	-211.653
239	VDDC	890.004	-211.653	-890.004	-211.653
240	VDDC_SUBCORE	1090.002	-11.646	-1090.002	-11.646
241	VDDC_SUBCORE	1396.119	-24.588	-1396.119	-24.588
242	VSSC	-1374.999	1263.348	1374.999	1263.348
243	VSSC	-1269.996	1563.354	1269.996	1563.354
244	VSSC	-1175.001	1263.348	1175.001	1263.348
245	VSSC	-1269.996	1763.352	1269.996	1763.352
246	VSSC	-1249.998	-71.649	1249.998	-71.649
247	VSSC	-975.003	1263.348	975.003	1263.348
248	VSSC	-1050.000	-71.649	1050.000	-71.649
249	VSSC	-1040.001	1563.354	1040.001	1563.354
250	VSSC	-840.003	-71.649	840.003	-71.649
251	VSSC	-840.003	128.349	840.003	128.349
252	VSSC	-840.003	328.347	840.003	328.347
253	VSSC	-840.003	828.351	840.003	828.351
254	VSSC	-840.003	1028.349	840.003	1028.349
255	VSSC	-805.002	1368.351	805.002	1368.351

Table 19: 286-Bump WLCSP Coordinates (Cont.)

Bump#	Signal Name	Package Bump Side View (0,0 center of die)		Package Top Side View (0,0 center of die)	
		X	Y	X	Y
256	VSSC	-639.996	828.351	639.996	828.351
257	VSSC	-639.996	1028.349	639.996	1028.349
258	VSSC	-439.998	128.349	439.998	128.349
259	VSSC	-439.998	328.734	439.998	328.734
260	VSSC	-439.998	-71.649	439.998	-71.649
261	VSSC	94.998	-606.654	-94.998	-606.654
262	VSSC	94.998	-806.652	-94.998	-806.652
263	VSSC	204.996	193.347	-204.996	193.347
264	VSSC	204.996	1028.349	-204.996	1028.349
265	VSSC	204.996	628.353	-204.996	628.353
266	VSSC	204.996	828.351	-204.996	828.351
267	VSSC	133.104	-1457.550	-133.104	-1457.550
268	VSSC	305.004	-446.652	-305.004	-446.652
269	VSSC	204.996	393.354	-204.996	393.354
270	VSSC	499.998	193.347	-499.998	193.347
271	VSSC	457.401	-1457.550	-457.401	-1457.550
272	VSSC	499.998	-806.652	-499.998	-806.652
273	VSSC	505.002	-446.652	-505.002	-446.652
274	VSSC	499.998	468.351	-499.998	468.351
275	VSSC	499.998	668.349	-499.998	668.349
276	VSSC	499.998	-6.651	-499.998	-6.651
277	VSSC	699.996	-806.652	-699.996	-806.652
278	VSSC	699.996	-606.654	-699.996	-606.654
279	VSSC	699.996	-6.651	-699.996	-6.651
280	VSSC	660.603	-1457.550	-660.603	-1457.550
281	VSSC	900.003	68.346	-900.003	68.346
282	VSSC	1090.002	-211.653	-1090.002	-211.653
283	VSSC	1100.001	668.349	-1100.001	668.349
284	VSSC	1229.997	508.347	-1229.997	508.347
285	VSSC	1229.997	308.349	-1229.997	308.349
286	VSSC	1290.000	-211.653	-1290.000	-211.653

Signal Descriptions

The signal name, type, and description of each pin in the BCM4339 is listed in [Table 20](#). The symbols shown under Type indicate pin directions (I/O = bidirectional, I = input, O = output) and the internal pull-up/pull-down characteristics (PU = weak internal pull-up resistor and PD = weak internal pull-down resistor), if any.

Table 20: FCFBGA, WLPGA, and WLCSP Signal Descriptions

WLPGA Ball#	FCFBGA Ball#	WLCSP Bump#	Signal Name	Type	Description
WLAN and Bluetooth RF Signal Interface					
N7	W10	118	WRF_RFIN_2G	I	2.4 GHz Bluetooth and WLAN receiver shared input.
N5	W8	93	BT_RF_TX	O	Bluetooth PA output.
N12	W18	102	WRF_RFIN_5G	I	5 GHz WLAN receiver input.
N8	W12	115	WRF_RFOUT_2G	O	2.4 GHz WLAN PA output.
N11	W16	106	WRF_RFOUT_5G	O	5 GHz WLAN PA output.
J7	V11	121	WRF_TSSI_A	I	5 GHz TSSI input from an optional external power amplifier/power detector.
H7	V10	122	WRF_RES_EXT/ WRF_GPIO_OUT/ WRF_TSSI_G	I/O	GPIO or 2.4 GHz TSSI input from an optional external power amplifier/power detector.
RF Switch Control Lines					
F12	J19	145	RF_SW_CTRL_0	O	Programmable RF switch control lines. The control lines are programmable via the driver and NVRAM file.
F11	J17	146	RF_SW_CTRL_1	O	
E12	J18	147	RF_SW_CTRL_2	O	
E11	G19	148	RF_SW_CTRL_3	O	
D12	H17	149	RF_SW_CTRL_4	O	
F8	G17	150	RF_SW_CTRL_5	O	
H9	G18	151	RF_SW_CTRL_6	O	
G7	J16	152	RF_SW_CTRL_7	O	
E10	G16	153	RF_SW_CTRL_8	O	
F5	H16	154	RF_SW_CTRL_9	O	
WLAN PCI Express Interface					
–	A19	–	PCIE_CLKREQ_L	OD	PCIe clock request signal which indicates when the REFCLK to the PCIe interface can be gated. 1 = the clock can be gated 0 = the clock is required
–	B16	–	PERST_L	I (PU)	PCIe System Reset. This input is the PCIe reset as defined in the PCIe base specification version 1.1.

Table 20: FCFBGA, WLBGA, and WLCSP Signal Descriptions (Cont.)

WLBGA Ball#	FCFBGA Ball#	WLCSP Bump#	Signal Name	Type	Description
–	B13	–	PAD_RDN0	I	Receiver differential pair (x1 lane).
–	C13	–	PAD_RDP0	I	
–	A18	–	PAD_REFCLKN	I	PCIE Differential Clock inputs (negative and positive). 100 MHz differential.
–	B18	–	PAD_REFCLKP	I	
–	B15	–	PAD_TDN0	O	Transmitter differential pair (x1 lane).
–	B14	–	PAD_TDP0	O	
–	B19	–	PCI_PME_L	OD	PCI power management event output. Used to request a change in the device or system power state. The assertion and deassertion of this signal is asynchronous to the PCIe reference clock. This signal has an open-drain output structure, as per the PCI Bus Local Bus Specification, revision 2.3.
–	–	–	PAD_TESTP	–	PCIe test pin.
–	–	–	PAD_TESTN	–	

WLAN SDIO Bus Interface

Note: These signals can also have alternate functionality depending on package and host interface mode. Refer to [Table 28: “BCM4339 GPIO/SDIO Alternative Signal Functions,” on page 118](#) for additional details.

B11	B11	171	SDIO_CLK	I	SDIO clock input.
B12	C11	172	SDIO_CMD	I/O	SDIO command line.
B10	C10	173	SDIO_DATA_0	I/O	SDIO data line 0.
C10	A11	174	SDIO_DATA_1	I/O	SDIO data line 1.
D10	C9	175	SDIO_DATA_2	I/O	SDIO data line 2.
C11	B9	176	SDIO_DATA_3	I/O	SDIO data line 3.

Table 20: FCFBGA, WLBGA, and WLCSP Signal Descriptions (Cont.)

WLBGA Ball#	FCFBGA Ball#	WLCSP Bump#	Signal Name	Type	Description
WLAN GPIO Interface					
Note: The GPIO signals can be multiplexed via software and the JTAG_SEL pin to behave as various specific functions. See Table 28: "BCM4339 GPIO/SDIO Alternative Signal Functions," on page 118 for additional details.					
B6	D9	189	GPIO_0	I/O	Programmable GPIO pins.
C6	C16	190	GPIO_1	I/O	Note: These GPIO signals can be configured by software: as either inputs or outputs, to have internal pull-ups or pull-downs enabled or disabled, and to use either a high or low polarity upon assertion.
D6	C8	191	GPIO_2	I/O	
B5	A7	192	GPIO_3	I/O	
C5	B5	193	GPIO_4	I/O	
D5	A5	194	GPIO_5	I/O	
C4	C7	195	GPIO_6	I/O	
D4	B7	196	GPIO_7	I/O	
H1	E8	197	GPIO_8	I/O	
–	–	198	GPIO_9	I/O	
–	–	199	GPIO_10	I/O	
–	–	200	GPIO_11	I/O	
–	–	201	GPIO_12	I/O	
–	A3	202	GPIO_14	I/O	
–	D8	203	GPIO_13	I/O	
–	D6	204	GPIO_15	I/O	
JTAG Interface					
E5	C6	205	JTAG_SEL	I/O	JTAG select. Pull high to select the JTAG interface. If the JTAG interface is not used, this pin may be left floating or connected to ground. Note: See Table 28: "BCM4339 GPIO/SDIO Alternative Signal Functions," on page 118 for the JTAG signal pins.
Clocks					
H12	P19	138	WRF_XTAL_IN	I	XTAL oscillator input.
J12	R19	142	WRF_XTAL_OUT	O	XTAL oscillator output.
B4	J7	39	LPO_IN	I	External sleep clock input (32.768 kHz).
H3	W3	56	CLK_REQ	O	Reference clock request (shared by BT and WLAN).
FM Transceiver and SFLASH					
–	N3	49	BT_SF_MOSI	I/O	SFLASH_SI
–	P3	46	BT_SF_CLK	I/O	SFLASH_CLK

Table 20: FCFBGA, WLBGA, and WLCSP Signal Descriptions (Cont.)

WLBGA Ball#	FCFBGA Ball#	WLCSP Bump#	Signal Name	Type	Description
–	R1	47	BT_SF_CSN	I/O	SFLASH_CSN
–	R2	48	BT_SF_MISO	I/O	SFLASH_SO
N2	–	78	FM_RFIN	I	FM Radio antenna port.
–	–	75	FM_RFAUX	I	FM radio auxiliary antenna port.
K1	–	86	FM_DAC_VOUT1/ FM_AOUT1	O	FM DAC output 1.
L1	–	85	FM_DAC_VOUT2/ FM_AOUT2	O	FM DAC output 2.
Bluetooth PCM					
G2	–	46	BT_PCM_CLK/BT_PCMCLK	I/O	PCM clock; can be master (output) or slave (input).
G1	–	48	BT_PCM_IN	I	PCM data input.
J3	–	49	BT_PCM_OUT	O	PCM data output.
H2	–	47	BT_PCM_SYNC	I/O	PCM sync; can be master (output) or slave (input).
Bluetooth USB Interface					
–	N1	40	HUSB_DN	I/O	USB (Host) data negative. Negative terminal of the USB transceiver.
–	N2	41	HUSB_DP	I/O	USB (Host) data positive. Positive terminal of the USB transceiver.
Bluetooth UART					
E6	T3	50	BT_UART_CTS_N/ BT_UART_CTS	I	UART clear-to-send. Active-low clear-to-send signal for the HCI UART interface.
F6	V1	51	BT_UART_RTS_N/ BT_UART_RTS/BT_LED	O	UART request-to-send. Active-low request-to-send signal for the HCI UART interface. BT LED control pin.
G6	W1	52	BT_UART_RXD/ BT_RFDISABLE2	I	UART serial input. Serial data input for the HCI UART interface. BT RF disable pin 2.
F7	W2	53	BT_UART_TXD	O	UART serial output. Serial data output for the HCI UART interface.
Bluetooth/FM I2S					
J6	R3	44	BT_I2S_CLK	I/O	I ² S clock, can be master (output) or slave (input).
K6	U2	42	BT_I2S_DO	I/O	I ² S data output.
K5	U3	43	BT_I2S_DI	I/O	I ² S data input.

Table 20: FCFBGA, WLBGA, and WLCSP Signal Descriptions (Cont.)

WLBGA Ball#	FCFBGA Ball#	WLCSP Bump#	Signal Name	Type	Description
H6	U1	45	BT_I2S_WS	I/O	I ² S WS; can be master (output) or slave (input).
Bluetooth Test Mode					
–	U1	55	BT_TM1	I/O	ARM JTAG mode.
Bluetooth GPIO					
–	–	59	BT_GPIO_2	I/O	Bluetooth general-purpose I/O.
–	–	60	BT_GPIO_3	I/O	Bluetooth general-purpose I/O.
–	C19	61	BT_GPIO_4	I/O	Bluetooth general-purpose I/O.
–	–	62	BT_GPIO_5	I/O	Bluetooth general-purpose I/O.
M6	–	91	BT_AGPIO	I/O	BT analog GPIO pin.
Miscellaneous					
B3	D5	3	WL_REG_ON	I	Used by PMU to power up or power down the internal BCM4339 regulators used by the WLAN section. Also, when deasserted, this pin holds the WLAN section in reset. This pin has an internal 200 kΩ pull-down resistor that is enabled by default. It can be disabled through programming.
D3	C5	32	BT_REG_ON	I	Used by PMU to power up or power down the internal BCM4339 regulators used by the Bluetooth/FM section. Also, when deasserted, this pin holds the Bluetooth/FM section in reset. This pin has an internal 200 kΩ pull-down resistor that is enabled by default. It can be disabled through programming.
K3	M3	57	BT_DEV_WAKE	I/O	Bluetooth DEV_WAKE.
J2	V3	58	BT_HOST_WAKE	I/O	Bluetooth HOST_WAKE.
B8	–	179	HSIC_STROBE/STROBE	I/O	Unsupported. This pin can be connected to ground or left unconnected (no-connect).
B7	–	180	HSIC_DATA/DATA	I/O	Unsupported. This pin can be connected to ground or left unconnected (no-connect).
B9	–	181	RREFHSIC	I	Unsupported. Leave this pin unconnected (no-connect).
Integrated Voltage Regulators					
C2	C3	15	SR_VDDBATA5V	I	Quiet VBAT.
C1	B1, B2, C1	11, 12, 14	SR_VDDBATP5V	I	Power VBAT.

Table 20: FCFBGA, WLBGA, and WLCSP Signal Descriptions (Cont.)

WLBGA Ball#	FCFBGA Ball#	WLCSP Bump#	Signal Name	Type	Description
B2	A2, B2	6–10, 13	SR_VLX	O	Cbuck switching regulator output. Refer to Table 45 on page 151 for details of the inductor and capacitor required on this output.
D1	F1, F2	16, 19, 23, 26	LDO_VDD1P5	I	LNLDO input.
F2	L1	27, 30, 34, 36	LDO_VDDBAT5V	I	LDO VBAT.
H11	N19	136	WRF_XTAL_VDD1P5/ WRF_XTAL_BUCK_VDD1P5	I	XTAL LDO input (1.35V).
K12	T19	141	WRF_XTAL_VDD1P2/ WRF_XTAL_OUT_VDD1P2	O	XTAL LDO output (1.2V).
E2	K2	24	VOUT_LNLDO	O	Output of LNLDO.
D2	G2	17, 18, 20	VOUT_CLDO	O	Output of core LDO.
F1	J2	33	VOUT_BTLDO2P5	O	Output of BT LDO.
E1	H1	22, 25, 28	VOUT_3P3	O	LDO 3.3V output.
–	H2	29	VOUT_3P3_SENSE	O	Voltage sense pin for LDO 3.3V output.
Bluetooth Supplies					
N6	V8	92	BT_PAVDD/BT_PAVDD2P5	PWR	Bluetooth PA power supply.
N4	W5	96	BT_LNAVDD/ BT_LNAVDD1P2	PWR	Bluetooth LNA power supply.
L4	W6	90	BT_IFVDD/BT_IFVDD1P2	PWR	Bluetooth IF block power supply.
M4	V6	98	BT_PLLVDD/ BT_PLLVDD1P2	PWR	Bluetooth RF PLL power supply.
N3	V5	99	BT_VCOVDD/ BT_VCOVDD1P2	PWR	Bluetooth RF power supply.
–	–	55	BT_VDDC_ISO_1	PWR	Core supply for power-on/off island VDDC_G.
–	–	66	BT_VDDC_ISO_2	PWR	Core supply for power-on/off island VDDB.
FM Transceiver Supplies					
–	–	87	FM_VCOVDD	PWR	FM VCO supply.
–	–	80	FM_LNAVDD	PWR	FM LNA power supply.
N1	–	–	FM_LNAVCOVDD1P2	PWR	FM LNA VCO power supply.
L2	–	84	FM_PLLVDD/ FM_PLLVDD1P2	PWR	FM PLL power supply.
–	–	79	FM_IFVDD	PWR	FM IF power supply.
–	–	82	FM_DAC_AVDD	PWR	FM DAC power supply.

Table 20: FCFBGA, WLBGA, and WLCSP Signal Descriptions (Cont.)

WLBGA Ball#	FCFBGA Ball#	WLCSP Bump#	Signal Name	Type	Description
J1	–	–	FM_AUDIOVDD1P2	PWR	FM Audio power supply.
WLAN Supplies					
–	L15	127, 128, 130, 131	WRF_BUCK_VDD1P5	PWR	Internal capacitor-less LDO supply.
H8	–	–	WRF_WL_LNLDOIN_VDD1P5	PWR	LNLDO 1.35V supply.
K9	V19	132	WRF_SYNTN_VBAT_VDD3P3	PWR	Synth VDD 3.3V supply.
L9	V14	112	WRF_PADRV_VBAT_VDD3P3	PWR	PA Driver VBAT supply.
N10	V15	107, 110	WRF_PA5G_VBAT_VDD3P3	PWR	5 GHz PA 3.3V VBAT supply.
N9	V13	113, 114	WRF_PA2G_VBAT_VDD3P3	PWR	2 GHz PA 3.3V VBAT supply.
K10	U18	134	WRF_MMD_VDD1P2	PWR	1.2V supply.
K11	T18	139	WRF_PFD_VDD1P2	PWR	1.2V supply.
Miscellaneous Supplies					
–	L18	155	OTP_VDD33	PWR	OTP 3.3V supply.
C7, C12, G4, G5, G8	E10, E11, G14, H14, K7	213–241	VDDC/WL_VDDC	PWR	1.2V core supply for WLAN.
F3	B3	210–212	VDDIO /VDDIO2	PWR	1.8V–3.3V supply for WLAN. Must be directly connected to PMU_VDDIO and BT_VDDIO on the PCB.
H5, J4	L7, M7	67–74	BT_VDDC	PWR	1.2V core supply for BT.
–	L2	37, 38	PMU_VDDIO	PWR	1.8V–3.3V supply for PMU controls. Must be directly connected to VDDIO and BT_VDDIO on the PCB.
H4	L3	63–65	BT_VDDIO	PWR	1.8V–3.3V supply for BT. Must be directly connected to PMU_VDDIO and VDDIO on the PCB.
D9	A9	177, 178	VDDIO_SD	PWR	1.8V–3.3V supply for SDIO pads.
E7	K17	156, 157	VDDIO_RF	PWR	IO supply for RF switch control pads (3.3V).
C8	–	184	AVDD12PLL/ HSIC_AVDD12PLL	PWR	HSIC is not supported. Connect this pin to ground to minimize leakage.
C9	–	185	DVDD12HSIC/ HSIC_DVDD12	PWR	HSIC is not supported. Connect this pin to ground to minimize leakage.
G12	L19	143	BBPLL_AVDD1P2	PWR	1.2V supply for baseband PLL.
–	D18	159	PLL_AVDD1P2	PWR	1.2V supply for PCIe PLL.

Table 20: FCFBGA, WLBGA, and WLCSP Signal Descriptions (Cont.)

WLBGA Ball#	FCFBGA Ball#	WLCSP Bump#	Signal Name	Type	Description
–	D19	167	AVDD1P2	PWR	1.2V supply for PCIe.
Ground					
H10	L12	126	WRF_VCO_GND1P2/ WRF_VCO_GND	GND	VCO/LOGEN ground.
–	–	183	DVDD12HSIC2	GND	Supply for DVDD12HSIC2.
K7	R12	124	WRF_AFE_GND1P2	GND	AFE ground.
J8	M12	129	WRF_BUCK_GND1P5	GND	Internal capacitor-less LDO ground.
M7	T10	119	WRF_LNA_2G_GND1P2	GND	2 GHz internal LNA ground.
M12	T15	101	WRF_LNA_5G_GND1P2	GND	5 GHz internal LNA ground.
L8	R13	125	WRF_TX_GND1P2	GND	TX ground.
L10	R14	108	WRF_PADRV_VBAT_GND3 P3	GND	PAD ground.
G11	M15, P18	137	WRF_XTAL_GND1P2	GND	XTAL ground.
L7	P11	117, 120	WRF_RX2G_GND1P2	GND	RX 2GHz ground.
L12	T16	103	WRF_RX5G_GND1P2	GND	RX 5GHz ground.
–	R15	104	WRF_LOGEN_GND1P2	GND	LOGEN ground.
–	M11	123	WRF_LOGENG_GND1P2	GND	LOGEN ground.
L11	–	–	WRF_LO_GND1P2_1	GND	LO ground.
K8	–	–	WRF_LO_GND1P2_2	GND	LO ground.
–	U15, V16	105, 109	WRF_PA5G_VBAT_GND3P 3	GND	5 GHz PA ground.
–	R11, V12	111, 116	WRF_PA2G_VBAT_GND3P 3	GND	2 GHz PA ground.
M11	–	–	WRF_PA_VBAT_GND3P3_1	GND	PA ground.
M10	–	–	WRF_PA_VBAT_GND3P3_2	GND	PA ground.
M9	–	–	WRF_PA_VBAT_GND3P3_3	GND	PA ground.
M8	–	–	WRF_PA_VBAT_GND3P3_4	GND	PA ground.
J9	P14	133	WRF_MMD_GND1P2	GND	Ground.
J11	N15	135	WRF_CP_GND1P2/ WRF_CP_GND	GND	Ground.
J10	P15	140	WRF_PFD_GND1P2	GND	Ground.
D7, D11, E3, E8, J5, K4	H9–H12, J8, J12, K8, K12, L8, L11, M8–M10	31, 35, 161, 163, 168, 242–286	VSSC	GND	Core ground for WLAN and BT.
B1	D1, E1, E2	1, 2, 4, 5	SR_PVSS	GND	Power ground.
C3	H8	21	PMU_AVSS	GND	Quiet ground.
D8	–	182	AGND12PLL/ HSIC_AGNDPLL	GND	PLL ground.
M5	T8	94	BT_PAVSS	GND	Bluetooth PA ground.

Table 20: FCFBGA, WLBGA, and WLCSP Signal Descriptions (Cont.)

WLBGA Ball#	FCFBGA Ball#	WLCSP Bump#	Signal Name	Type	Description
–	R8	95	BT_LNAVSS	GND	Bluetooth LNA ground.
L6	R9	89	BT_IFVSS	GND	Bluetooth IF block ground.
L5	R7	97	BT_PLLVSS	GND	Bluetooth PLL ground.
M3	P8	100	BT_VCOVSS	GND	Bluetooth VCO ground.
M1	–	83	FM_VCOVSS	GND	FM VCO Ground.
M2	–	77	FM_LNAVSS	GND	FM LNA Ground.
L3	–	88	FM_PLLVSS	GND	FM PLL Ground.
–	–	76	FM_IFVSS	GND	FM IF ground.
–	–	81	FM_DAC_VSS	GND	FM DAC ground.
K2	–	–	FM_AUDIOVSS	GND	FM Audio Ground.
G10	L13	144	AVSS_BBPLL/BBPLLAVSS	GND	Baseband PLL ground.
–	D13, D16	–	PCIE_VSS	GND	PCIe ground.
–	–	209	VSSC	GND	Ground.
–	–	208	VSSC	GND	Ground.
–	–	207	VSSC	GND	Ground.
–	–	206	VSSC	GND	Ground.
No Connect					
A2, A3, A4, A6, A7, A9, A10, A11	F5, G5, W19	158, 160, 162, 164, 165, 166, 169, 170, 186, 187, 188	NC	–	No connect

WLAN GPIO Signals and Strapping Options

The pins listed in [Table 21](#) are sampled at power-on reset (POR) to determine the various operating modes. Sampling occurs a few milliseconds after an internal POR or deassertion of the external POR. After the POR, each pin assumes the GPIO or alternative function specified in the signal descriptions table. Each strapping option pin has an internal pull-up (PU) or pull-down (PD) resistor that determines the default mode. To change the mode, connect an external PU resistor to VDDIO or a PD resistor to GND, using a 10 kΩ resistor or less.



Note: Refer to the reference board schematics for more information.

Table 21: WLAN GPIO Functions and Strapping Options

<i>Pin Name</i>	<i>FCBGA Pin #</i>	<i>WLBGA Pin #</i>	<i>WLCSP Pin #</i>	<i>Default Function</i>	<i>Description</i>
GPIO_7	B7	D4	196	1	SDIO_SEL ^a
GPIO_8	E8	H1	197	0	SDIO_PADVDDIO
GPIO_14	A3	–	202	0	PCIE_DISABLE
SDIO_CLK	B11	B11	171	1	CPU-LESS/SPROM_DISABLE ^a
SDIO_DATA_2	C9	D10	175	1	SPI_SEL ^a

a. See [Table 22](#), [Table 23](#), and [Table 24](#).

Table 22: SDIO/gSPI I/O Voltage Selection (All Packages)

<i>SDIO_SEL</i>	<i>SPI_SEL</i>	<i>SDIO_PADVDDIO</i>	<i>Mode</i>
1	X	0	1.8V I/O
1	X	1	3.3V I/O
0	1	0	1.8V I/O
0	1	1	3.3V I/O
0	0	X	3.3V I/O

Table 23: Host Interface Selection (FCBGA Package only)

SDIO_SEL	SPI_SEL	PCIE_DISABLE	SPROM_DISABLE	
			E ^a	Mode
1	X	0	X	SDIO and PCIe mode
1	X	1	X	SDIO mode
0	1	0	X	gSPI and PCIe mode
0	1	1	X	gSPI mode
0	0	0	0	PCIe mode with SPROM on the SDIO pins ^b
0	0	0	1	PCIe mode (no SPROM)

- a. SPROM_DISABLE strapping is valid only in the FCBGA package and only used if SDIO/gSPI is disabled.
- b. SPROM is only available for PCIe mode.

Table 24: Host Interface Selection (WLBGA and WLCSP Packages^a)

SDIO_SEL	SPI_SEL	CPULESS	Mode
1	X	X	SDIO Mode (3.3V or 1.8V I/O)
0	1	X	gSPI Mode (3.3V or 1.8V I/O)
0	0	0	Unsupported
0	0	1	Unsupported

- a. PCIe and SPROM modes are not available in the WLBGA and WLCSP packages.

Table 25: OTP/SPROM Select

Mode	SDIO CIS	PCIE Configuration
PCIe Disabled	From OTP if OTP is programmed; ELSE default CIS.	–
PCIe Enabled	Default CIS	From SPROM if SPROM is present; ELSE from OTP (if programmed); ELSE default configuration.

Multiplexed Bluetooth GPIO Signals

The Bluetooth GPIO pins (BT_GPIO_0 to BT_GPIO_7) are multiplexed pins and can be programmed to be used as GPIOs or for other Bluetooth interface signals such as I²S. The specific function for a given BT_GPIO_X pin is chosen by programming the Pad Function Control register for that specific pin. Table 26 shows the possible options for each BT_GPIO_X pin. Note that each BT_GPIO_X pin's Pad Function Control register setting is independent (BT_GPIO_1 can be set to pad function 7 at the same time that BT_GPIO_3 is set to pad function 0). When the Pad Function Control register is set to 0, the BT_GPIOs do not have specific functions assigned to them and behave as generic GPIOs. The A_GPIO_X pins described below are multiplexed behind the BCM4339's PCM and I²S interface pins.

Table 26: GPIO Multiplexing Matrix

Pin Name	Pad Function Control Register Setting								
	0	1	2	3	4	5	6	7	15
BT_UART_CTS_N	UART_CTS_N	-	-	-	-	-	-	A_GPIO[1]	-
BT_UART_RTS_N	UART_RTS_N	-	-	-	-	-	-	A_GPIO[0]	-
BT_UART_RXD	UART_RXD	-	-	-	-	-	-	GPIO[5]	-
BT_UART_TXD	UART_TXD	-	-	-	-	-	-	GPIO[4]	-
BT_PCM_IN	A_GPIO[3]	PCM_IN	PCM_IN	HCLK	-	-	-	I2S_SSDI/ MSDI	SF_MISO
BT_PCM_OUT	A_GPIO[2]	PCM_OUT	PCM_OUT	LINK_IND	-	I2S_MSDO	-	I2S_SSDO	SF_MOSI
BT_PCM_SYNC	A_GPIO[1]	PCM_SYNC	PCM_SYNC	HCLK	INT_LPO	I2S_MWS	-	I2S_SWS	SF_SPI_CS N
BT_PCM_CLK	A_GPIO[0]	PCM_CLK	PCM_CLK	-	-	I2S_MSCK	-	I2S_SSCK	SF_SPI_CLK
BT_I2S_DO	A_GPIO[5]	PCM_OUT	-	-	I2S_SSDO	I2S_MSDO	-	STATUS	-
BT_I2S_DI	A_GPIO[6]	PCM_IN	-	HCLK	I2S_SSDI/ MSDI	-	-	TX_CON_FX	-
BT_I2S_WS	GPIO[7]	PCM_SYNC	-	LINK_IND	-	I2S_MWS	-	I2S_SWS	-
BT_I2S_CLK	GPIO[6]	PCM_CLK	-	-	INT_LPO	I2S_MSCK	-	I2S_SSCK	-
BT_GPIO_5 ^a	GPIO[5]	HCLK	-	I2S_MSCK	I2S_SSCK	-	-	CLK_REQ	-
BT_GPIO_4 ^a	GPIO[4]	LINK_IND	-	I2S_MSDO	I2S_SSDO	-	-	-	-
BT_GPIO_3 ^a	GPIO[3]	-	-	I2S_MWS	I2S_SWS	-	-	-	-
BT_GPIO_2 ^a	GPIO[2]	-	-	-	I2S_SSDI/ MSDI	-	-	-	-
BT_GPIO_1	GPIO[1]	-	-	-	-	-	-	CLASS1[2]	-
BT_GPIO_0	GPIO[0]	-	-	-	clk_12p288	-	-	-	-
CLK_REQ	WL/ BT_CLK_REQ	-	-	-	-	-	-	A_GPIO[7]	-

a. Available only in the WLCSP package.

The multiplexed GPIO signals are described in [Table 27](#).

Table 27: Multiplexed GPIO Signals

Pin Name	Type	Description
UART_CTS_N	I	Host UART clear to send.
UART_RTS_N	O	Device UART request to send.
UART_RXD	I	Device UART receive data.
UART_TXD	O	Host UART transmit data.
PCM_IN	I	PCM data input.
PCM_OUT	O	PCM data output.
PCM_SYNC	I/O	PCM sync signal, can be master (output) or slave (input).
PCM_CLK	I/O	PCM clock, can be master (output) or slave (input).
GPIO[7:0]	I/O	General-purpose I/O.
A_GPIO[7:0]	I/O	A group general-purpose I/O.
I2S_MSDO	O	I ² S master data output.
I2S_MWS	O	I ² S master word select.
I2S_MSCK	O	I ² S master clock.
I2S_SSCK	I	I ² S slave clock.
I2S_SSDO	O	I ² S slave data output.
I2S_SWS	I	I ² S slave word select.
I2S_SSDI/MSDI	I	I ² S slave/master data input.
STATUS	O	Signals Bluetooth priority status.
TX_CON_FX	I	WLAN-BT coexist. Transmission confirmation; permission for BT to transmit.
RF_ACTIVE	O	WLAN-BT coexist. Asserted (logic high) during local BT RX and TX slots.
LINK_IND	O	BT receiver/transmitter link indicator.
CLK_REQ	O	WLAN/BT clock request output.
SF_SPI_CLK	O	SFlash SCLK: serial clock (output from master).
SF_MISO	I	SFlash MISO; SOMI: master input, slave output (output from slave).
SF_MOSI	O	SFlash MOSI; SIMO: master output, slave input (output from master).
SF_SPI_CSN	O	SFlash SS: slave select (active low, output from master).

GPIO/SDIO Alternative Signal Functions

Table 28: BCM4339 GPIO/SDIO Alternative Signal Functions ^{a b}

Pins	WLPGA SDIO	WLCSP SDIO	FCBGA PCIE	FCBGA SDIO
GPIO_0	WL_HOST_WAKE	WL_HOST_WAKE	WL_HOST_WAKE	WL_HOST_WAKE
GPIO_1	WL_DEV_WAKE	WL_DEV_WAKE	WL_RF_DISABLE_L	WL_RF_DISABLE_L
GPIO_2	TCK, GCI_GPIO_1, or UART RX	TCK or GCI_GPIO_1	TCK, GCI_GPIO_1, or UART RX	TCK, GCI_GPIO_1, or UART RX
GPIO_3	TMS or GCI_GPIO_0	TMS or GCI_GPIO_0	TMS or GCI_GPIO_0	TMS or GCI_GPIO_0
GPIO_4	TDI or SECI_IN	TDI	TDI or SECI_IN	TDI or SECI_IN
GPIO_5	TDO or SECI_OUT	TDO	TDO or SECI_OUT	TDO or SECI_OUT
GPIO_6	TRST_L or UART TX	TRST_L	TRST_L or UART TX	TRST_L or UART TX
GPIO_7	[Strap, tied High]	[Strap, tied High]	[Strap, tied Low]	[Strap, tied High]
GPIO_8	[Strap, tied High or Low]	[Strap, tied High or Low]	–	[Strap, tied High or Low]
GPIO_9	N/A	–	N/A	N/A
GPIO_10	N/A	SECI_IN	N/A	N/A
GPIO_11	N/A	SECI_OUT	N/A	N/A
GPIO_12	N/A	UART_TX	N/A	N/A
GPIO_13	N/A	UART_RX	WL_LED	WL_LED
GPIO_14	N/A	–	–	–
GPIO_15	N/A	–	–	–
SDIO_CLK	SDIO_CLK	SDIO_CLK	[Strap, tied High]	SDIO_CLK
SDIO_CMD	SDIO_CMD	SDIO_CMD	SPROM_CS	SDIO_CMD
SDIO_DATA_0	SDIO_DATA_0	SDIO_DATA_0	SPROM_CLK	SDIO_DATA_0
SDIO_DATA_1	SDIO_DATA_1	SDIO_DATA_1	SPROM_MISO	SDIO_DATA_1
SDIO_DATA_2	SDIO_DATA_2	SDIO_DATA_2	[Strap, tied Low]	SDIO_DATA_2
SDIO_DATA_3	SDIO_DATA_3	SDIO_DATA_3	SPROM_MOSI	SDIO_DATA_3

a. N/A = Pin not available in this package.

b. JTAG signals (TCK, TDI, TDO, TMS, and TRST_L) are selected when JTAG_SEL pin is high.

I/O States

The following notations are used in [Table 29](#):

- I: Input signal
- O: Output signal
- I/O: Input/Output signal
- PU = Pulled up
- PD = Pulled down
- NoPull = Neither pulled up nor pulled down

Table 29: I/O States

Name	I/O	Keeper ^a	Active Mode	Low Power State/Sleep (All Power Present)	Power-down ^b (BT_REG_ON and WL_REG_ON Held Low)	Out-of-Reset; Before SW Download (BT_REG_ON High; WL_REG_ON High)	(WL_REG_ON High and BT_REG_ON = 0) and VDDIOs Are Present	Power Rail
WL_REG_ON	I	N	Input; PD (pull-down can be disabled)	Input; PD (pull-down can be disabled)	Input; PD (of 200K)	Input; PD (of 200K)	Input; PD (of 200K)	–
BT_REG_ON	I	N	Input; PD (pull down can be disabled)	Input; PD (pull down can be disabled)	Input; PD (of 200K)	Input; PD (of 200K)	Input; PD (of 200K)	–
CLK_REQ	I/O	Y	Open drain or push-pull (programmable). Active high.	Open drain or push-pull (programmable). Active high.	PD	Open drain. Active high	Open drain. Active high.	BT_VDDIO
BT_HOST_WAKE	I/O	Y	Input/Output; PU, PD, NoPull (programmable)	Input/Output; PU, PD, NoPull (programmable)	High-Z, NoPull	Input, PU	Input, PD	BT_VDDIO
BT_DEV_WAKE	I/O	Y	Input/Output; PU, PD, NoPull (programmable)	Input; PU, PD, NoPull (programmable)	High-Z, NoPull	Input, PD	Input, PD	BT_VDDIO
BT_GPIO 2, 3, 4, 5	I/O	Y	Input/Output; PU, PD, NoPull (programmable)	Input/Output; PU, PD, NoPull (programmable)	High-Z, NoPull	Input, PD	Input, PD	BT_VDDIO
BT_UART_CTS	I	Y	Input; NoPull	Input; NoPull	High-Z, NoPull	Input; PU	Input; PU	BT_VDDIO
BT_UART_RTS	O	Y	Output; NoPull	Output; NoPull	High-Z, NoPull	Input; PU	Input; PU	BT_VDDIO
BT_UART_RXD	I	Y	Input; PU	Input; NoPull	High-Z, NoPull	Input; PU	Input; PU	BT_VDDIO
BT_UART_TXD	O	Y	Output; NoPull	Output; NoPull	High-Z, NoPull	Input; PU	Input; PU	BT_VDDIO
SDIO Data	I/O	N	Input/Output; PU (SDIO Mode)	Input; PU (SDIO Mode)	High-Z, NoPull	Input; PU (SDIO Mode)	Input; PU (SDIO Mode)	VDDIO_SD
SDIO CMD	I/O	N	Input/Output; PU (SDIO Mode)	Input; PU (SDIO Mode)	High-Z, NoPull	Input; PU (SDIO Mode)	Input; PU (SDIO Mode)	VDDIO_SD
SDIO_CLK	I	N	Input; NoPull	Input; noPull	High-Z, NoPull	Input; noPull	Input; noPull	VDDIO_SD

Table 29: I/O States (Cont.)

Name	I/O	Keeper^a	Active Mode	Low Power State/Sleep (All Power Present)	Power-down^b (BT_REG_ON and WL_REG_ON Held Low)	Out-of-Reset; Before SW Download (BT_REG_ON High; WL_REG_ON High)	(WL_REG_ON High and BT_REG_ON = 0) and VDDIOs Are Present	Power Rail
BT_PCM_CLK	I/O	Y	Input; NoPull ^c	Input; NoPull ^c	High-Z, NoPull	Output	Input, PD	BT_VDDIO
BT_PCM_IN	I/O	Y	Input; NoPull ^c	Input; NoPull ^c	High-Z, NoPull	Input; NoPull, Hi-Z	Input, PD	BT_VDDIO
BT_PCM_OUT	I/O	Y	Input; NoPull ^c	Input; NoPull ^c	High-Z, NoPull	Output	Input, PD	BT_VDDIO
BT_PCM_SYNC	I/O	Y	Input; NoPull ^c	Input; NoPull ^c	High-Z, NoPull	Output	Input, PD	BT_VDDIO
BT_I2S_WS	I/O	Y	PD ^d	PD ^d	High-Z, NoPull	Input, PD	Input, PD	BT_VDDIO
BT_I2S_CLK	I/O	Y	PD ^d	PD ^d	High-Z, NoPull	Input, PD	Input, PD	BT_VDDIO
BT_I2S_DI	I/O	Y	PD ^d	Input; PD ^d	High-Z, NoPull	Input, PD	Input, PD	BT_VDDIO
BT_I2S_DO	I/O	Y	Output ^d	Output ^d	High-Z, NoPull	Input, PD	Input, PD	BT_VDDIO
WL GPIO_0	I/O	Y	Input/Output; PU, PD, NoPull (programmable [Default: PD])	Input/Output; PU, PD, NoPull (programmable [Default: PD])	High-Z, NoPull	Input; PD	Input; PD	VDDIO
WL GPIO_1	I/O	Y	Input/Output; PU, PD, NoPull (programmable [Default: NoPull])	Input/Output; PU, PD, NoPull (programmable [Default: NoPull])	High-Z, NoPull	Input; NoPull	Input; NoPull	VDDIO
WL GPIO_2	I/O	Y	Input/Output; PU, PD, NoPull (programmable [Default: NoPull])	Input/Output; PU, PD, NoPull (programmable [Default: NoPull])	High-Z, NoPull	Input; NoPull	Input; NoPull	VDDIO
WL GPIO_3	I/O	Y	Input/Output; PU, PD, NoPull (programmable [Default: PD])	Input/Output; PU, PD, NoPull (programmable [Default: PD])	High-Z, NoPull	Input; PD	Input; PD	VDDIO
WL GPIO_4	I/O	Y	Input/Output; PU, PD, NoPull (programmable [Default: NoPull])	Input/Output; PU, PD, NoPull (programmable [Default: NoPull])	High-Z, NoPull	Input; NoPull	Input; NoPull	VDDIO
WL GPIO_5	I/O	Y	Input/Output; PU, PD, NoPull (programmable [Default: PD])	Input/Output; PU, PD, NoPull (programmable [Default: PD])	High-Z, NoPull	Input; PD	Input; PD	VDDIO
WL GPIO_6	I/O	Y	Input/Output; PU, PD, NoPull (programmable [Default: NoPull])	Input/Output; PU, PD, NoPull (programmable [Default: NoPull])	High-Z, NoPull	Input; NoPull	Input; NoPull	VDDIO
WL GPIO_7	I/O	Y	Input/Output; PU, PD, NoPull (programmable [Default: NoPull])	Input/Output; PU, PD, NoPull (programmable [Default: NoPull])	High-Z, NoPull	Input; NoPull	Input; NoPull	VDDIO
WL GPIO_8	I/O	Y	Input/Output; PU, PD, NoPull (programmable [Default: PD]) ^e	Input/Output; PU, PD, NoPull (programmable [Default: PD]) ^e	High-Z, NoPull	Input; PD ^e	Input; PD ^e	VDDIO

Table 29: I/O States (Cont.)

Name	I/O	Keeper^a	Active Mode	Low Power State/Sleep (All Power Present)	Power-down^b (BT_REG_ON and WL_REG_ON Held Low)	Out-of-Reset; Before SW Download (BT_REG_ON High; WL_REG_ON High)	(WL_REG_ON High and BT_REG_ON = 0) and VDDIOs Are Present	Power Rail
WL GPIO_9 ^f	I/O	Y	Input/Output; PU, PD, NoPull (programmable [Default: PD])	Input/Output; PU, PD, NoPull (programmable [Default: PD])	High-Z, NoPull	Input; PD	Input; PD	VDDIO
WL GPIO_10 ^f	I/O	Y	Input/Output; PU, PD, NoPull (programmable [Default: NoPull])	Input/Output; PU, PD, NoPull (programmable [Default: NoPull])	High-Z, NoPull	Input; NoPull	Input; NoPull	VDDIO
WL GPIO_11 ^f	I/O	Y	Input/Output; PU, PD, NoPull (programmable [Default: PD])	Input/Output; PU, PD, NoPull (programmable [Default: PD])	High-Z, NoPull	Input; PD	Input; PD	VDDIO
WL GPIO_12 ^f	I/O	Y	Input/Output; PU, PD, NoPull (programmable [Default: NoPull])	Input/Output; PU, PD, NoPull (programmable [Default: NoPull])	High-Z, NoPull	Input; NoPull	Input; NoPull	VDDIO
WL GPIO_13 ^g	I/O	Y	Input/Output; PU, PD, NoPull (programmable [Default: NoPull])	Input/Output; PU, PD, NoPull (programmable [Default: NoPull])	High-Z, NoPull	Input; NoPull	Input; NoPull	VDDIO
WL GPIO_14 ^g	I/O	Y	Input/Output; PU, PD, NoPull (programmable [Default: NoPull])	Input/Output; PU, PD, NoPull (programmable [Default: NoPull])	High-Z, NoPull	Input; NoPull	Input; NoPull	VDDIO
WL GPIO_15 ^g	I/O	Y	Input/Output; PU, PD, NoPull (programmable [Default: NoPull])	Input/Output; PU, PD, NoPull (programmable [Default: NoPull])	High-Z, NoPull	Input; NoPull	Input; NoPull	VDDIO
RF_SW_CTRL_X	O	N	Output, NoPull	Output, NoPull	High-Z, NoPull	Output, NoPull	Output, NoPull	VDDIO_RF

- a. Keeper column: N = pad has no keeper. Y = pad has a keeper. Keeper is always active except in Power-down state. If there is no keeper, and it is an input and there is Nopull, then the pad should be driven to prevent leakage due to floating pad (SDIO_CLK, for example).
- b. In the Power-down state (xx_REG_ON=0): High-Z; NoPull => the pad is disabled because power is not supplied.
- c. Depending on whether the PCM interface is enabled and the configuration of PCM is in master or slave mode, it can be either output or input.
- d. Depending on whether the I²S interface is enabled and the configuration of I²S is in master or slave mode, it can be either output or input
- e. NoPull when in SDIO mode.
- f. Only available in WLCSP package.
- g. Only available in WLCSP and FCBGA packages.

Section 14: DC Characteristics

Absolute Maximum Ratings



Caution! The absolute maximum ratings in [Table 30](#) indicate levels where permanent damage to the device can occur, even if these limits are exceeded for only a brief duration. Functional operation is not guaranteed under these conditions. Operation at absolute maximum conditions for extended periods can adversely affect long-term reliability of the device.

Table 30: Absolute Maximum Ratings

Rating	Symbol	Value	Unit
DC supply for VBAT and PA driver supply ^a	VBAT	-0.5 to +6.0	V
DC supply voltage for digital I/O	VDDIO	-0.5 to 3.9	V
DC supply voltage for RF switch I/Os	VDDIO_RF	-0.5 to 3.9	V
DC input supply voltage for CLDO and LNLDO	–	-0.5 to 1.575	V
DC supply voltage for RF analog	VDD1P2	-0.5 to 1.32	V
DC supply voltage for core	VDDC	-0.5 to 1.32	V
WRF_TCXO_VDD	–	-0.5 to 3.63	V
Maximum undershoot voltage for I/O ^b	V _{undershoot}	-0.5	V
Maximum overshoot voltage for I/O ^b	V _{overshoot}	VDDIO + 0.5	V
Maximum junction temperature	T _j	125	°C

- The maximum continuous voltage is 5.25V. Voltage transients up to 6.0V (for up to 10 seconds), cumulative duration over the lifetime of the device, are allowed. Voltage transients as high as 5.5V (for up to 250 seconds), cumulative duration over the lifetime of the device, are allowed.
- Duration not to exceed 25% of the duty cycle.

Environmental Ratings

The environmental ratings are shown in [Table 31](#).

Table 31: Environmental Ratings

Characteristic	Value	Units	Conditions/Comments
Ambient Temperature (T_A)	-30 to +85	°C	Functional operation ^a
Storage Temperature	-40 to +125	°C	–
Relative Humidity	Less than 60	%	Storage
	Less than 85	%	Operation

- a. Functionality is guaranteed but specifications require derating at extreme temperatures; see the specification tables for details.

Electrostatic Discharge Specifications

Extreme caution must be exercised to prevent electrostatic discharge (ESD) damage. Proper use of wrist and heel grounding straps to discharge static electricity is required when handling these devices. Always store unused material in its antistatic packaging.

Table 32: ESD Specifications

Pin Type	Symbol	Condition	ESD Rating	Unit
ESD, Handling Reference: NQY00083, Section 3.4, Group D9, Table B	ESD_HAND_HBM	Human body model contact discharge per JEDEC EID/JESD22-A114	±1000	V
CDM	ESD_HAND_CDM	Charged device model contact discharge per JEDEC EIA/JESD22- C101	±300	V

Recommended Operating Conditions and DC Characteristics



Caution! Functional operation is not guaranteed outside of the limits shown in [Table 33](#) and operation outside these limits for extended periods can adversely affect long-term reliability of the device.

Table 33: Recommended Operating Conditions and DC Characteristics

Parameter	Symbol	Value			Unit
		Minimum	Typical	Maximum	
DC supply voltage for VBAT	VBAT	3.0 ^a	–	5.25 ^b	V
DC supply voltage for core	VDD	1.14	1.2	1.26	V
DC supply voltage for RF blocks in chip	VDD1P2	1.14	1.2	1.26	V
DC supply voltage for TCXO input buffer	WRF_TCXO_VDD	1.62	1.8	1.98	V
DC supply voltage for digital I/O	VDDIO, VDDIO_SD	1.71	–	3.63	V
DC supply voltage for RF switch I/Os	VDDIO_RF	3.13	3.3	3.46	V
External TSSI input	WRF_TSSI_A, WRF_TSSI_G	0.15	–	0.95	V
Internal POR threshold	Vth_POR	0.4	–	0.7	V
SDIO Interface I/O Pins					
For VDDIO_SD = 1.8V:					
Input high voltage	VIH	1.27	–	–	V
Input low voltage	VIL	–	–	0.58	V
Output high voltage @ 2 mA	VOH	1.40	–	–	V
Output low voltage @ 2 mA	VOL	–	–	0.45	V
For VDDIO_SD = 3.3V:					
Input high voltage	VIH	0.625 × VDDIO	–	–	V
Input low voltage	VIL	–	–	0.25 × VDDIO	V
Output high voltage @ 2 mA	VOH	0.75 × VDDIO	–	–	V
Output low voltage @ 2 mA	VOL	–	–	0.125 × VDDIO	V
Other Digital I/O Pins					
For VDDIO = 1.8V:					
Input high voltage	VIH	0.65 × VDDIO	–	–	V
Input low voltage	VIL	–	–	0.35 × VDDIO	V

Table 33: Recommended Operating Conditions and DC Characteristics (Cont.)

Parameter	Symbol	Value			Unit
		Minimum	Typical	Maximum	
Output high voltage @ 2 mA	VOH	VDDIO – 0.45	–	–	V
Output low voltage @ 2 mA	VOL	–	–	0.45	V
For VDDIO = 3.3V:					
Input high voltage	VIH	2.00	–	–	V
Input low voltage	VIL	–	–	0.80	V
Output high voltage @ 2 mA	VOH	VDDIO – 0.4	–	–	V
Output low Voltage @ 2 mA	VOL	–	–	0.40	V
RF Switch Control Output Pins^c					
For VDDIO_RF = 3.3V:					
Output high voltage @ 2 mA	VOH	VDDIO – 0.4	–	–	V
Output low voltage @ 2 mA	VOL	–	–	0.40	V
Output capacitance	C _{OUT}	–	–	5	pF

- a. The BCM4339 is functional across this range of voltages. Optimal RF performance specified in the data sheet, however, is guaranteed only for 3.13V < VBAT < 4.8V.
- b. The maximum continuous voltage is 5.25V. Voltage transients up to 6.0V (for up to 10 seconds), cumulative duration over the lifetime of the device are allowed. Voltage transients as high as 5.5V (for up to 250 seconds), cumulative duration over the lifetime of the device are allowed.
- c. Programmable 2 mA to 16 mA drive strength. Default is 10 mA.

Section 15: Bluetooth RF Specifications

Unless otherwise stated, limit values apply for the conditions specified in [Table 31: “Environmental Ratings,”](#) on page 123 and [Table 33: “Recommended Operating Conditions and DC Characteristics,”](#) on page 124. Typical values apply for the following conditions:

- VBAT = 3.6V
- Ambient temperature +25°C

Figure 41: Port Locations for Bluetooth Testing

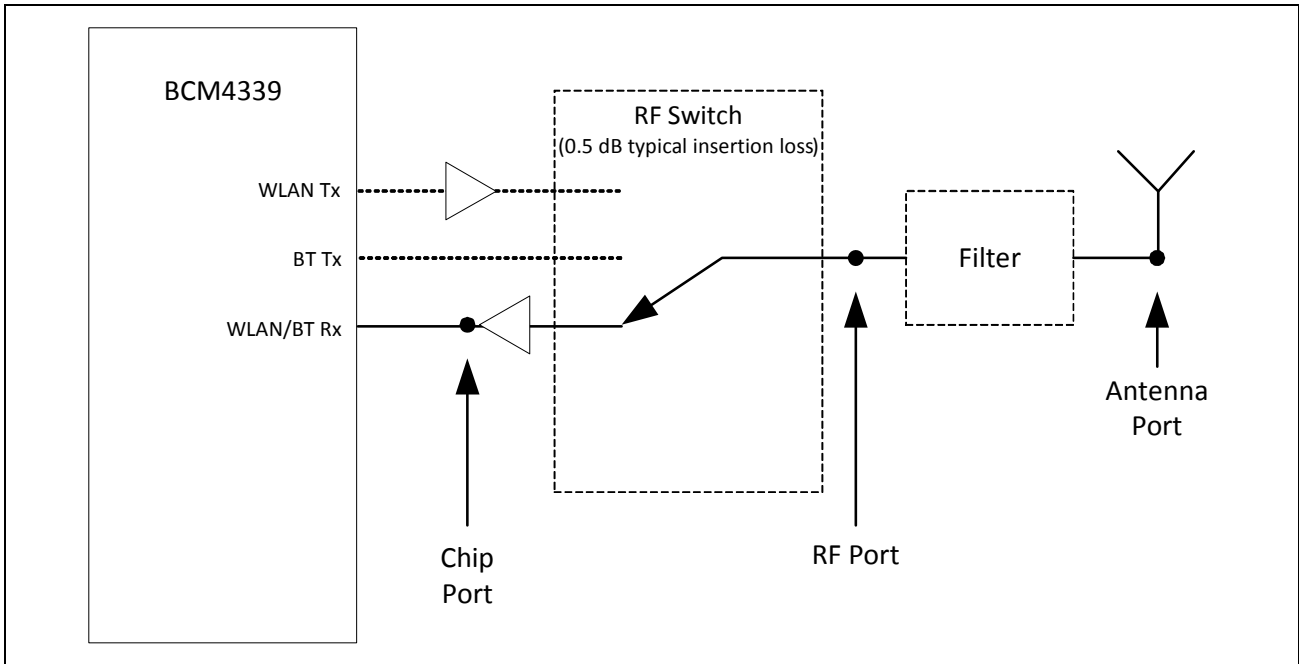

Note: All Bluetooth specifications are measured at the chip port unless otherwise specified.

Table 34: Bluetooth Receiver RF Specifications

Parameter	Conditions	Minimum	Typical	Maximum	Unit
Note: The specifications in this table are measured at the chip port output unless otherwise specified.					
General					
Frequency range	–	2402	–	2480	MHz
RX sensitivity	GFSK, 0.1% BER, 1 Mbps	–	–93.5	–	dBm
	$\pi/4$ -DQPSK, 0.01% BER, 2 Mbps	–	–95.5	–	dBm
	8-DPSK, 0.01% BER, 3 Mbps	–	–89.5	–	dBm
Input IP3	–	–16	–	–	dBm
Maximum input at antenna	–	–	–	–20	dBm
RX LO Leakage					
2.4 GHz band	–	–	–90.0	–80.0	dBm
Interference Performance^a					
C/I co-channel	GFSK, 0.1% BER	–	8	–	dB
C/I 1-MHz adjacent channel	GFSK, 0.1% BER	–	–7	–	dB
C/I 2-MHz adjacent channel	GFSK, 0.1% BER	–	–38	–	dB
C/I \geq 3-MHz adjacent channel	GFSK, 0.1% BER	–	–56	–	dB
C/I image channel	GFSK, 0.1% BER	–	–31	–	dB
C/I 1-MHz adjacent to image channel	GFSK, 0.1% BER	–	–46	–	dB
C/I co-channel	$\pi/4$ -DQPSK, 0.1% BER	–	9	–	dB
C/I 1-MHz adjacent channel	$\pi/4$ -DQPSK, 0.1% BER	–	–11	–	dB
C/I 2-MHz adjacent channel	$\pi/4$ -DQPSK, 0.1% BER	–	–39	–	dB
C/I \geq 3-MHz adjacent channel	$\pi/4$ -DQPSK, 0.1% BER	–	–55	–	dB
C/I image channel	$\pi/4$ -DQPSK, 0.1% BER	–	–23	–	dB
C/I 1-MHz adjacent to image channel	$\pi/4$ -DQPSK, 0.1% BER	–	–43	–	dB
C/I co-channel	8-DPSK, 0.1% BER	–	17	–	dB
C/I 1 MHz adjacent channel	8-DPSK, 0.1% BER	–	–4	–	dB
C/I 2 MHz adjacent channel	8-DPSK, 0.1% BER	–	–37	–	dB
C/I \geq 3-MHz adjacent channel	8-DPSK, 0.1% BER	–	–53	–	dB
C/I Image channel	8-DPSK, 0.1% BER	–	–16	–	dB
C/I 1-MHz adjacent to image channel	8-DPSK, 0.1% BER	–	–37	–	dB

Table 34: Bluetooth Receiver RF Specifications (Cont.)

Parameter	Conditions	Minimum	Typical	Maximum	Unit
Out-of-Band Blocking Performance (CW)					
30–2000 MHz	0.1% BER	–	–10.0	–	dBm
2000–2399 MHz	0.1% BER	–	–27	–	dBm
2498–3000 MHz	0.1% BER	–	–27	–	dBm
3000 MHz–12.75 GHz	0.1% BER	–	–10.0	–	dBm
Out-of-Band Blocking Performance, Modulated Interferer					
GFSK (1 Mbps)^b					
698–716 MHz	WCDMA	–	–13.5	–	dBm
776–849 MHz	WCDMA	–	–13.8	–	dBm
824–849 MHz	GSM850	–	–13.5	–	dBm
824–849 MHz	WCDMA	–	–14.3	–	dBm
880–915 MHz	E-GSM	–	–13.1	–	dBm
880–915 MHz	WCDMA	–	–13.1	–	dBm
1710–1785 MHz	GSM1800	–	–18.1	–	dBm
1710–1785 MHz	WCDMA	–	–17.4	–	dBm
1850–1910 MHz	GSM1900	–	–19.4	–	dBm
1850–1910 MHz	WCDMA	–	–18.8	–	dBm
1880–1920 MHz	TD-SCDMA	–	–19.7	–	dBm
1920–1980 MHz	WCDMA	–	–19.6	–	dBm
2010–2025 MHz	TD-SCDMA	–	–20.4	–	dBm
2500–2570 MHz	WCDMA	–	–20.4	–	dBm
2500–2570 MHz ^e	Band 7	–	–30.5	–	dBm
2300–2400 MHz ^f	Band 40	–	–34.0	–	dBm
2570–2620 MHz ^c	Band 38	–	–30.8	–	dBm
2545–2575 MHz ^d	XGP Band	–	–29.5	–	dBm
$\pi/4$ DPSK (2 Mbps)^b					
698–716 MHz	WCDMA	–	–9.8	–	dBm
776–794 MHz	WCDMA	–	–9.7	–	dBm
824–849 MHz	GSM850	–	–10.7	–	dBm
824–849 MHz	WCDMA	–	–11.4	–	dBm
880–915 MHz	E-GSM	–	–10.4	–	dBm
880–915 MHz	WCDMA	–	–10.2	–	dBm
1710–1785 MHz	GSM1800	–	–15.8	–	dBm
1710–1785 MHz	WCDMA	–	–15.4	–	dBm
1850–1910 MHz	GSM1900	–	–16.6	–	dBm
1850–1910 MHz	WCDMA	–	–16.4	–	dBm
1880–1920 MHz	TD-SCDMA	–	–17.9	–	dBm

Table 34: Bluetooth Receiver RF Specifications (Cont.)

Parameter	Conditions	Minimum	Typical	Maximum	Unit
1920–1980 MHz	WCDMA	–	–16.8	–	dBm
2010–2025 MHz	TD-SCDMA	–	–18.6	–	dBm
2500–2570 MHz	WCDMA	–	–20.4	–	dBm
2500–2570 MHz ^e	Band 7	–	–31.9	–	dBm
2300–2400 MHz ^f	Band 40	–	–35.3	–	dBm
2570–2620 MHz ^c	Band 38	–	–31.8	–	dBm
2545–2575 MHz ^d	XGP Band	–	–31.1	–	dBm
8DPSK (3 Mbps)^b					
698–716 MHz	WCDMA	–	–12.6	–	dBm
776–794 MHz	WCDMA	–	–12.6	–	dBm
824–849 MHz	GSM850	–	–12.7	–	dBm
824–849 MHz	WCDMA	–	–13.7	–	dBm
880–915 MHz	E-GSM	–	–12.8	–	dBm
880–915 MHz	WCDMA	–	–12.6	–	dBm
1710–1785 MHz	GSM1800	–	–18.1	–	dBm
1710–1785 MHz	WCDMA	–	–17.4	–	dBm
1850–1910 MHz	GSM1900	–	–19.1	–	dBm
1850–1910 MHz	WCDMA	–	–18.6	–	dBm
1880–1920 MHz	TD-SCDMA	–	–19.3	–	dBm
1920–1980 MHz	WCDMA	–	–18.9	–	dBm
2010–2025 MHz	TD-SCDMA	–	–20.4	–	dBm
2500–2570 MHz	WCDMA	–	–21.4	–	dBm
2500–2570 MHz ^e	Band 7	–	–31.0	–	dBm
2300–2400 MHz ^f	Band 40	–	–34.5	–	dBm
2570–2620 MHz ^c	Band 38	–	–31.2	–	dBm
2545–2575 MHz ^d	XGP Band	–	–30.0	–	dBm

Table 34: Bluetooth Receiver RF Specifications (Cont.)

Parameter	Conditions	Minimum	Typical	Maximum	Unit
Spurious Emissions					
30 MHz–1 GHz		–	–95	–62	dBm
1–12.75 GHz		–	–70	–47	dBm
851–894 MHz		–	–147	–	dBm/Hz
925–960 MHz		–	–147	–	dBm/Hz
1805–1880 MHz		–	–147	–	dBm/Hz
1930–1990 MHz		–	–147	–	dBm/Hz
2110–2170 MHz		–	–147	–	dBm/Hz

- The maximum value represents the actual Bluetooth specification required for Bluetooth qualification as defined in the version 4.1 specification.
- Bluetooth reference level is taken at the 3 dB RX desense on each of the modulation schemes.
- Interferer: 2380 MHz, BW=10 MHz; measured at 2480 MHz.
- Interferer: 2355 MHz, BW=10 MHz; measured at 2480 MHz.
- Interferer: 2560 MHz, BW=10 MHz; measured at 2480 MHz.
- Interferer: 2360 MHz, BW=10 MHz; measured at 2402 MHz.

Table 35: Bluetooth Transmitter RF Specifications

Parameter	Conditions	Minimum	Typical	Maximum	Unit
Note: The specifications in this table are measured at the chip port output unless otherwise specified.					
General					
Frequency range		2402	–	2480	MHz
Basic rate (GFSK) TX power at Bluetooth		11.0	13.0	–	dBm
QPSK TX Power at Bluetooth		8.0	10.0	–	dBm
8PSK TX Power at Bluetooth		8.0	10.0	–	dBm
Power control step		2	4	8	dB
Note: Output power is with TCA and TSSI enabled.					
GFSK In-Band Spurious Emissions					
–20 dBc BW	–	–	0.93	1	MHz
EDR In-Band Spurious Emissions					
1.0 MHz < M – N < 1.5 MHz	M – N = the frequency range for which the spurious emission is measured relative to the transmit center frequency.	–	–38	–26.0	dBc
1.5 MHz < M – N < 2.5 MHz		–	–31	–20.0	dBm
M – N ≥ 2.5 MHz ^a		–	–43	–40.0	dBm

Table 35: Bluetooth Transmitter RF Specifications (Cont.)

Parameter	Conditions	Minimum	Typical	Maximum	Unit
Out-of-Band Spurious Emissions					
30 MHz to 1 GHz	–	–	–	–36.0 ^{b, c}	dBm
1 GHz to 12.75 GHz	–	–	–	–30.0 ^{b, d, e}	dBm
1.8 GHz to 1.9 GHz	–	–	–	–47.0	dBm
5.15 GHz to 5.3 GHz	–	–	–	–47.0	dBm
GPS Band Spurious Emissions					
Spurious emissions	–	–	–103	–	dBm
Out-of-Band Noise Floor^f					
65–108 MHz	FM RX	–	–147	–	dBm/Hz
776–794 MHz	CDMA2000	–	–147	–	dBm/Hz
869–960 MHz	cdmaOne, GSM850	–	–147	–	dBm/Hz
925–960 MHz	E-GSM	–	–147	–	dBm/Hz
1570–1580 MHz	GPS	–	–146	–	dBm/Hz
1805–1880 MHz	GSM1800	–	–145	–	dBm/Hz
1930–1990 MHz	GSM1900, cdmaOne, WCDMA	–	–144	–	dBm/Hz
2110–2170 MHz	WCDMA	–	–141	–	dBm/Hz
2500–2570 MHz	Band 7	–	–140	–	dBm/Hz
2300–2400 MHz	Band 40	–	–140	–	dBm/Hz
2570–2620 MHz	Band 38	–	–140	–	dBm/Hz
2545–2575 MHz	XGP Band	–	–140	–	dBm/Hz

- a. The typical number is measured at ± 3 MHz offset.
- b. The maximum value represents the value required for Bluetooth qualification as defined in the v4.1 specification.
- c. The spurious emissions during Idle mode are the same as specified in [Table 35 on page 130](#).
- d. Specified at the Bluetooth Antenna port.
- e. Meets this specification using a front-end band-pass filter.
- f. Transmitted power in cellular and FM bands at the Bluetooth Antenna port. See [Figure 41 on page 126](#) for location of the port.

Table 36: Local Oscillator Performance

Parameter	Minimum	Typical	Maximum	Unit
LO Performance				
Lock time	–	72	–	μs
Initial carrier frequency tolerance	–	±25	±75	kHz
Frequency Drift				
DH1 packet	–	±8	±25	kHz
DH3 packet	–	±8	±40	kHz
DH5 packet	–	±8	±40	kHz
Drift rate	–	5	20	kHz/50 μs
Frequency Deviation				
00001111 sequence in payload ^a	140	155	175	kHz
10101010 sequence in payload ^b	115	140	–	kHz
Channel spacing	–	1	–	MHz

a. This pattern represents an average deviation in payload.

b. Pattern represents the maximum deviation in payload for 99.9% of all frequency deviations.

Table 37: BLE RF Specifications

Parameter	Conditions	Minimum	Typical	Maximum	Unit
Frequency range	–	2402		2480	MHz
RX sense ^a	GFSK, 0.1% BER, 1 Mbps	–	–95.5	–	dBm
TX power ^b	–	–	8.5	–	dBm
Mod Char: delta F1 average	–	225	255	275	kHz
Mod Char: delta F2 max ^c	–	99.9	–	–	%
Mod Char: ratio	–	0.8	0.95	–	%

a. Dirty TX is On.

b. BLE TX power can be increased to compensate for front-end losses such as BPF, diplexer, switch, etc.). The output is capped at 12 dBm out. The BLE TX power at the antenna port cannot exceed the 10 dBm specification limit.

c. At least 99.9% of all delta F2 max frequency values recorded over 10 packets must be greater than 185 kHz

Section 16: FM Receiver Specifications

Unless otherwise stated, limit values apply for the conditions specified in [Table 31: “Environmental Ratings,” on page 123](#) and [Table 33: “Recommended Operating Conditions and DC Characteristics,” on page 124](#). Typical values apply for the following conditions:

- VBAT = 3.6V
- Ambient temperature +25°C

Table 38: FM Receiver Specifications

Parameter	Conditions ^a	Typical		Units	
		Minimum	Maximum		
RF Parameters					
Operating frequency ^b	Frequencies inclusive	65	–	108	MHz
Sensitivity ^c	FM only SNR \geq 26 dB	–	0	–	dB μ V EMF
		–	1	–	μ V EMF
		–	–6	–	dBuV
Receiver adjacent channel selectivity ^{c, d}	Measured for 30 dB SNR at the audio output with best tune. Signal of interest: 23 dB μ V EMF (14.1 μ V EMF), At \pm 200 kHz.	–	51	–	dB
		–	62	–	dB
		–	–	–	–
Intermediate signal plus noise-to-noise ratio (S+N)/N ^c	Vin = 20 dB μ V EMF (10 μ V EMF)	45	53	–	dB
Intermodulation performance ^{c, d}	Blocker level increased until desired at 30 dB SNR Wanted Signal: 33 dB μ V EMF (45 μ V EMF) Modulated Interferer: At $f_{\text{Wanted}} \pm 400$ kHz and ± 4 MHz CW Interferer: At $f_{\text{Wanted}} \pm 800$ kHz and ± 8 MHz	–	55	–	dBc
AM suppression, mono ^c	Vin = 23 dB μ V EMF (14.1 μ V EMF) AM at 400 Hz with $m = 0.3$ No A-weighted or any other filtering applied.	40	–	–	dB

Table 38: FM Receiver Specifications (Cont.)

Parameter	Conditions ^a	Typical		Units	
		Minimum	Maximum		
RDS					
RDS Sensitivity ^{e, f}	RDS deviation = 1.2 kHz	–	16	–	dB μ V EMF
		–	6.3	–	μ V EMF
		–	10	–	dBuV
	RDS deviation = 2 kHz	–	12	–	dB μ V EMF
		–	4	–	μ V EMF
		–	6	–	dBuV
RDS selectivity ^f	Wanted Signal: 33 dB μ V EMF (45 μ V EMF), 2 kHz RDS deviation with best tune Interferer: $\Delta f = 40$ kHz, $f_{mod} = 1$ kHz				
	± 200 kHz	–	49	–	dB
	± 300 kHz	–	52	–	dB
	± 400 kHz	–	52	–	dB
RF input impedance		1.5	–	–	k Ω
Antenna tuning capacitor		2.5	–	30	pF
Maximum input level ^c	SNR > 26 dB	–	–	113	dB μ V EMF
		–	–	446	mV EMF
		–	–	107	dBuV
RF conducted emissions (measured into a 50 Ω load)	Local oscillator breakthrough measured on the reference port	–	–	–55	dBm
	869–894 MHz, 925–960 MHz, 1805–1880 MHz, 1930–1990 MHz. GPS	–	–	–90	dBm
RF blocking levels at the FM antenna input 40 dB SNR (assumes a 50 Ω at the radio input and excludes spurs)	GSM850, E-GSM (std), BW = 0.2 MHz, 824–849 MHz 880–915 MHz	–	7	–	dBm
	GSM850, E-GSM (edge), BW = 0.2 MHz, 824–849 MHz 880–915 MHz	–	–1	–	dBm
	GSM DCS 1800, PCS 1900 (std/edge), BW = 0.2 MHz, 1710–1785 MHz 1850–1910 MHz	–	12	–	dBm
	WCDMA: II(I), III(IV, X), BW = 5 MHz, 1850–1980 MHz (1920–1980 MHz), 1710–1785 MHz (1710–1755 MHz, 1710–1770 MHz)	–	12	–	dBm

Table 38: FM Receiver Specifications (Cont.)

Parameter	Conditions^a	Typical		Units	
		Minimum	Maximum		
	WCDMA: V(VI), VIII, XII, XIII, XIV, BW = 5 MHz, 824–849 MHz (830–840 MHz), 880–915 MHz	–	5	–	dBm
	CDMA2000, cdma One, BW = 1.25 MHz, 824–849 MHz, 887–925 MHz, 776–794 MHz	–	0	–	dBm
	CDMA2000, cdma One, BW = 1.25 MHz, 1850–1910 MHz, 1750–1780 MHz, 1920–1980 MHz	–	12	–	dBm
	Bluetooth, BW = 1 MHz, 2402–2480 MHz	–	11	–	dBm
	IEEE 802.11g/b, BW = 20 MHz, 2400–2483.5 MHz	–	11	–	dBm
	IEEE 802.11a, BW = 20 MHz, 4915–5825 MHz	–	6	–	dBm
2500–2570 MHz	Band 7	–	11	–	dBm
2300–2400 MHz	Band 40	–	11	–	dBm
2570–2620 MHz	Band 38	–	11	–	dBm
2545–2575 MHz	XGP band	–	11	–	dBm
Tuning					
Frequency step		10	–	–	kHz
Settling time	Single-frequency switch in any direction to a frequency within the bands 88–108 MHz or 76–90 MHz. Time measured to within 5 kHz of the final frequency.	–	150	–	µs
Search time	Total time for an automatic search to sweep from 88–108 MHz or 76–90 MHz (and reverse direction) assuming no channels are found.	–	–	8	sec
General Audio					
I ² S audio output level ^g		–14.5	–	–12.5	dBFS
Maximum audio output level ^h		–	–	0	dBFS
Audio DAC output level ^g		72	–	88	mV rms
Maximum DAC audio output level ^h		–	333	–	mV rms
Audio DAC output level difference ⁱ		–1	–	1	dB

Table 38: FM Receiver Specifications (Cont.)

Parameter	Conditions ^a	Typical			Units
		Minimum	I	Maximum	
Left and right AC mute	FM input signal fully muted with DAC enabled	60	–	–	dB
Left and right hard mute	FM input signal fully muted with DAC disabled	80	–	–	dB
Soft mute attenuation and start level	Muting is performed dynamically proportional to the FM wanted input signal C/N. The muting characteristic is fully programmable. Refer to “ Audio Features ” on page 66 for further details.	–	–	–	–
Maximum signal plus noise-to-noise ratio (S + N)/N, mono ⁱ		–	69	–	dB
Maximum signal plus noise-to-noise ratio (S + N)/N, stereo ^g		–	64	–	dB
Total harmonic distortion, mono	Vin = 66 dB μ V EMF (2 mV EMF), Δ f = 75 kHz, fmod = 400 Hz	–	–	0.8	%
	Δ f = 75 kHz, fmod = 1 kHz	–	–	0.8	%
	Δ f = 75 kHz, fmod = 3 kHz	–	–	0.8	%
	Δ f = 100 kHz, fmod = 1 kHz	–	–	1.0	%
Total harmonic distortion, stereo	Vin = 66 dB μ V EMF (2 mV EMF) Δ f = 67.5 kHz, fmod = 1 kHz, Δ f Pilot = 7.5 kHz, L = R	–	–	1.5	%
Audio spurious products ⁱ	Range from 300 Hz to 15 kHz, with respect to 1 kHz tone	–	–	–60	dBc
Audio bandwidth, upper (–3 dB point)	Vin = 66 dB μ V EMF (2 mV EMF) Δ f = 8 kHz, for 50 μ s	15	–	–	kHz
Audio bandwidth, lower (–3 dB point)		–	–	20	Hz
Audio in-band ripple	100 Hz to 13 kHz, Vin = 66 dB μ V EMF (2 mV EMF) Δ f = 8 kHz, for 50 μ s	–0.5	–	0.5	dB
Deemphasis time constant tolerance	With respect to 50 and 75 μ s	–	–	\pm 5	%
RSSI range	With 1 dB resolution and \pm 5 dB accuracy at room temp	3	–	83	dB μ V EMF
		1.41	–	14100	μ V EMF
		–3	–	77	dBuV
Stereo Decoder					
Stereo channel separation	Forced Stereo mode Vin = 66 dB μ V EMF (2 mV EMF), Δ f = 67.5 kHz, fmod = 1 kHz, Δ f Pilot = 6.75 kHz R = 0, L = 1	–	48	–	dB

Table 38: FM Receiver Specifications (Cont.)

Parameter	Conditions^a	Typical			Units
		Minimum	I	Maximum	
Mono stereo blend and switching	Blending and switching is dynamically proportional to the FM wanted input signal C/N. The blending and switching characteristics are fully programmable. Refer to “Audio Features” on page 66 for further details.				
Pilot suppression	Vin = 66 dBμV EMF (2 mV EMF), Δf = 75 kHz, fmod = 1 kHz	46	–	–	dB
Pause detection					
Audio level at which a pause is detected	Relative to 1 kHz tone, Δf = 22.5 kHz	–	–	–	–
	Four values in 3 dB steps	–21	–	–12	dB
Audio pause duration	Four values	20	–	40	ms

- Following conditions are applied to all relevant tests unless otherwise indicated: Pre-emphasis and de-emphasis of 50 us, R = L for mono, DAC Load ≥ 20 kΩ, BAF = 300 Hz to 15 kHz, and A-weighted filtering applied.
- Contact Broadcom regarding applications that operate between 65 and 76 MHz.
- Wanted Signal: Δf = 22.5 kHz, and fmod = 1 kHz.
- Interferer: Δf = 22.5 kHz, and fmod = 1 kHz.
- RDS sensitivity numbers are for 87.5–108 MHz only.
- Vin = Δf = 32 kHz, fmod = 1 kHz, Δf Pilot = 7.5 kHz, and 95% of blocks decoded with no errors after correction
- Vin = 66 dBμV EMF (2 mV EMF), Δf = 22.5 kHz, fmod = 1 kHz, and Δf Pilot = 6.75 kHz.
- Vin = 66 dBμV EMF (2 mV EMF), Δf = 100 kHz, fmod = 1 kHz, and Δf Pilot = 6.75 kHz.
- Vin = 66 dBμV EMF (2 mV EMF), Δf = 22.5 kHz, and fmod = 1 kHz.

Section 17: WLAN RF Specifications

Introduction

The BCM4339 includes an integrated dual-band direct conversion radio that supports the 2.4 GHz and the 5 GHz bands. This section describes the RF characteristics of the 2.4 GHz and 5 GHz radio.

Unless otherwise stated, limit values apply for the conditions specified in [Table 31: “Environmental Ratings,” on page 123](#) and [Table 33: “Recommended Operating Conditions and DC Characteristics,” on page 124](#). Typical values apply for the following conditions:

- VBAT = 3.6V
- Ambient temperature +25°C

Figure 42: Port Locations Showing Optional ePA and eLNA (Applies to 2.4 GHz and 5 GHz)

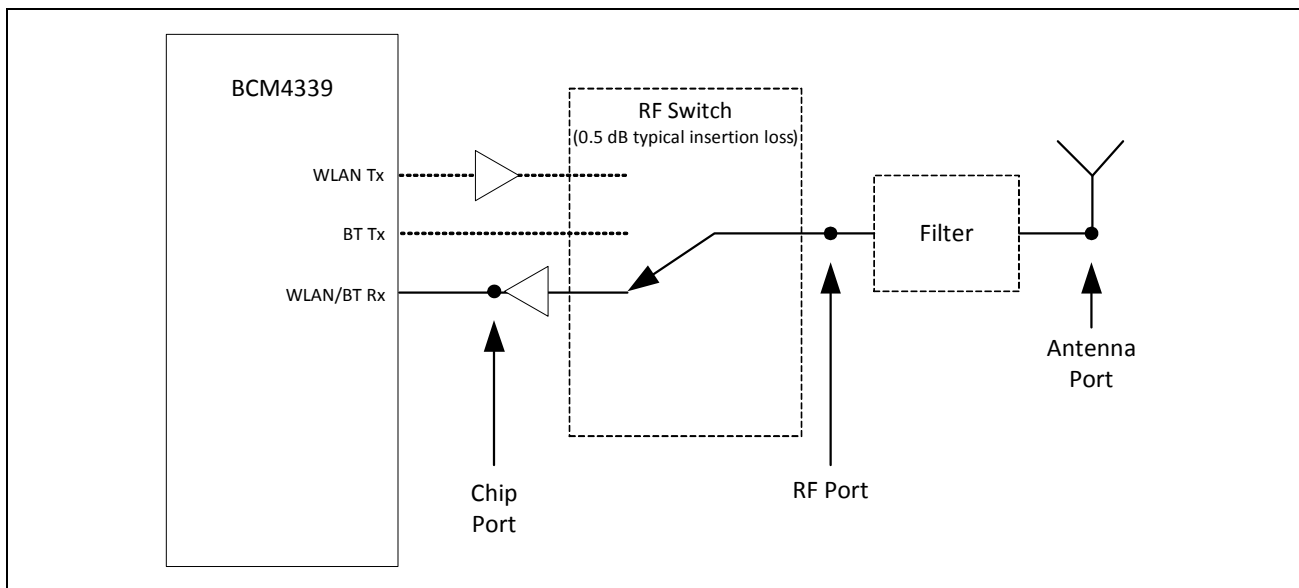

2.4 GHz Band General RF Specifications

Table 39: 2.4 GHz Band General RF Specifications

Item	Condition	Minimum	Typical	Maximum	Unit
TX/RX switch time	Including TX ramp down	–	–	5	µs
RX/TX switch time	Including TX ramp up	–	–	2	µs
Power-up and power-down ramp time	DSSS/CCK modulations	–	–	< 2	µs

WLAN 2.4 GHz Receiver Performance Specifications



Note: The specifications in [Table 40](#) are specified at the RF port and include the use of an external FEM with LNA from Broadcom's approved-vendor list (AVL), unless otherwise specified. Results with FEMs that are not on Broadcom's AVL are not guaranteed.

Table 40: WLAN 2.4 GHz Receiver Performance Specifications

Parameter	Condition/Notes	Minimum	Typical	Maximum	Unit
Frequency range	–	2400	–	2500	MHz
RX sensitivity IEEE 802.11b (8% PER for 1024 octet PSDU) ^a	1 Mbps DSSS	–	–98.4	–	dBm
	2 Mbps DSSS	–	–96.5	–	dBm
	5.5 Mbps DSSS	–	–93.7	–	dBm
	11 Mbps DSSS	–	–91.4	–	dBm
RX sensitivity IEEE 802.11g (10% PER for 1024 octet PSDU) ^a	6 Mbps OFDM	–	–95.5	–	dBm
	9 Mbps OFDM	–	–94.1	–	dBm
	12 Mbps OFDM	–	–93.2	–	dBm
	18 Mbps OFDM	–	–90.6	–	dBm
	24 Mbps OFDM	–	–87.3	–	dBm
	36 Mbps OFDM	–	–84.0	–	dBm
	48 Mbps OFDM	–	–79.3	–	dBm
RX sensitivity IEEE 802.11n (10% PER for 4096 octet PSDU) ^{a,b} . Defined for default parameters: 800 ns GI and non-STBC.	20 MHz channel spacing for all MCS rates				
	MCS0	–	–95.0	–	dBm
	MCS1	–	–92.7	–	dBm
	MCS2	–	–90.2	–	dBm
	MCS3	–	–87.1	–	dBm
	MCS4	–	–83.5	–	dBm
	MCS5	–	–78.9	–	dBm
	MCS6	–	–77.3	–	dBm
RX sensitivity IEEE 802.11n (10% PER for 4096 octet PSDU) ^{a,c} . Defined for default parameters: 800 ns GI and non-STBC.	40 MHz channel spacing for all MCS rates				
	MCS0	–	–92.8	–	dBm
	MCS1	–	–89.9	–	dBm
	MCS2	–	–87.5	–	dBm
	MCS3	–	–84.0	–	dBm
	MCS4	–	–80.9	–	dBm
	MCS5	–	–76.2	–	dBm
	MCS6	–	–74.7	–	dBm
MCS7	–	–73.3	–	dBm	

Table 40: WLAN 2.4 GHz Receiver Performance Specifications (Cont.)

Parameter	Condition/Notes		Minimum	Typical	Maximum	Unit
RX sensitivity IEEE 802.11ac (10% PER for 4096 octet PSDU) ^{a,d} . Defined for default parameters: 800 ns GI and non-STBC	20 MHz channel spacing for all MCS rates					
	MCS0		–	–94.3	–	dBm
	MCS1		–	–91.9	–	dBm
	MCS2		–	–90.1	–	dBm
	MCS3		–	–86.9	–	dBm
	MCS4		–	–83.4	–	dBm
	MCS5		–	–78.9	–	dBm
	MCS6		–	–77.3	–	dBm
	MCS7		–	–75.6	–	dBm
MCS8		–	–71.2	–	dBm	
RX sensitivity IEEE 802.11ac (10% PER for 4096 octet PSDU) ^{a,e} . Defined for default parameters: 800 ns GI and non-STBC.	40 MHz channel spacing for all MCS rates					
	MCS0		–	–91.5	–	dBm
	MCS1		–	–89.0	–	dBm
	MCS2		–	–87.2	–	dBm
	MCS3		–	–84.0	–	dBm
	MCS4		–	–80.8	–	dBm
	MCS5		–	–76.3	–	dBm
	MCS6		–	–74.7	–	dBm
	MCS7		–	–73.3	–	dBm
MCS8		–	–68.9	–	dBm	
RX sensitivity IEEE 802.11ac 20/40/80 MHz channel spacing with LDPC (10% PER for 4096 octet PSDU) at WLAN RF port. Defined for default parameters: 800 ns GI, LDPC coding, and non-STBC.	MCS7	20 MHz	–	–77.4	–	dBm
	MCS8	20 MHz	–	–74.7	–	dBm
	MCS7	40 MHz	–	–74.6	–	dBm
	MCS8	40 MHz	–	–71.6	–	dBm
	MCS9	40 MHz	–	–70.1	–	dBm
	MCS7	80 MHz	–	–71.5	–	dBm
	MCS8	80 MHz	–	–68.1	–	dBm
	MCS9	80 MHz	–	–66.0	–	dBm

Table 40: WLAN 2.4 GHz Receiver Performance Specifications (Cont.)

Parameter	Condition/Notes	Minimum	Typical	Maximum	Unit	
Blocking level for 3 dB RX sensitivity degradation (without external filtering) ^f	776–794 MHz	CDMA2000	–	–24	–	dBm
	824–849 MHz ^g	cdmaOne	–	–25	–	dBm
	824–849 MHz	GSM850	–	–15	–	dBm
	880–915 MHz	E-GSM	–	–16	–	dBm
	1710–1785 MHz	GSM1800	–	–18	–	dBm
	1850–1910 MHz	GSM1800	–	–19	–	dBm
	1850–1910 MHz	cdmaOne	–	–26	–	dBm
	1850–1910 MHz	WCDMA	–	–26	–	dBm
	1920–1980 MHz	WCDMA	–	–28.5	–	dBm
	2500–2570 MHz	Band 7	–	–45	–	dBm
	2300–2400 MHz	Band 40	–	–50	–	dBm
	2570–2620 MHz	Band 38	–	–45	–	dBm
	2545–2575 MHz	XGP Band	–	–45	–	dBm
In-band static CW jammer immunity (fc – 8 MHz < fcw < + 8 MHz)	RX PER < 1%, 54 Mbps OFDM, 1000 octet PSDU for: (RxSens + 23 dB < Rxlevel < max input level)	–80	–	–	dBm	
Input in-band IP3 ^a	Maximum LNA gain	–	–15.5	–	dBm	
	Minimum LNA gain	–	–1.5	–	dBm	
Maximum receive level @ 2.4 GHz	@ 1, 2 Mbps (8% PER, 1024 octets)	–3.5	–	–	dBm	
	@ 5.5, 11 Mbps (8% PER, 1024 octets)	–9.5	–	–	dBm	
	@ 6–54 Mbps (10% PER, 1024 octets)	–9.5	–	–	dBm	
	@ MCS0–7 rates (10% PER, 4095 octets)	–9.5	–	–	dBm	
	@ MCS8–9 rates (10% PER, 4095 octets)	–11.5	–	–	dBm	
LPF 3 dB bandwidth	–	9	–	36	MHz	
Adjacent channel rejection—DSSS (Difference between interfering and desired signal at 8% PER for 1024 octet PSDU with desired signal level as specified in Condition/Notes)	Desired and interfering signal 30 MHz apart					
	1 Mbps DSSS	–74 dBm	35	–	–	dB
	2 Mbps DSSS	–74 dBm	35	–	–	dB
	Desired and interfering signal 25 MHz apart					
	5.5 Mbps DSSS	–70 dBm	35	–	–	dB
	11 Mbps DSSS	–70 dBm	35	–	–	dB

Table 40: WLAN 2.4 GHz Receiver Performance Specifications (Cont.)

Parameter	Condition/Notes	Minimum	Typical	Maximum	Unit	
Adjacent channel rejection—OFDM (Difference between interfering and desired signal (25 MHz apart) at 10% PER for 1024 octet PSDU with desired signal level as specified in Condition/Notes)	6 Mbps OFDM	-79 dBm	16	–	–	dB
	9 Mbps OFDM	-78 dBm	15	–	–	dB
	12 Mbps OFDM	-76 dBm	13	–	–	dB
	18 Mbps OFDM	-74 dBm	11	–	–	dB
	24 Mbps OFDM	-71 dBm	8	–	–	dB
	36 Mbps OFDM	-67 dBm	4	–	–	dB
	48 Mbps OFDM	-63 dBm	0	–	–	dB
Adjacent channel rejection MCS0–9 (Difference between interfering and desired signal (25 MHz apart) at 10% PER for 4096 octet PSDU with desired signal level as specified in Condition/Notes)	54 Mbps OFDM	-62 dBm	-1	–	–	dB
	MCS0	-79 dBm	16	–	–	dB
	MCS1	-76 dBm	13	–	–	dB
	MCS2	-74 dBm	11	–	–	dB
	MCS3	-71 dBm	8	–	–	dB
	MCS4	-67 dBm	4	–	–	dB
	MCS5	-63 dBm	0	–	–	dB
	MCS6	-62 dBm	-1	–	–	dB
	MCS7	-61 dBm	-2	–	–	dB
MCS8	-59 dBm	-4	–	–	dB	
MCS9	-57 dBm	-6	–	–	dB	
Maximum receiver gain	–	–	–	95	–	dB
Gain control step	–	–	–	3	–	dB
RSSI accuracy ^h	Range -95 dBm ⁱ to -30 dBm	-5	–	5	–	dB
	Range above -30 dBm	-8	–	8	–	dB
Return loss	Z ₀ = 50Ω, across the dynamic range	10	11.5	13	–	dB
Receiver cascaded noise figure	At maximum gain	–	4	–	–	dB

- a. Derate by 1.5 dB for -30°C to -10°C and 55°C to 85°C.
- b. Sensitivity degradations for alternate settings in MCS modes. MM: 0.5 dB drop, and SGI: 2 dB drop.
- c. Sensitivity degradations for alternate settings in MCS modes. MM: 0.5 dB drop, and SGI: 2 dB drop.
- d. Sensitivity degradations for alternate settings in MCS modes. MM: 0.5 dB drop, and SGI: 2 dB drop.
- e. Sensitivity degradations for alternate settings in MCS modes. MM: 0.5 dB drop, and SGI: 2 dB drop.
- f. The cellular standard listed for each band indicates the type of modulation used to generate the interfering signal in that band for the purpose of this test. It is not intended to indicate any specific usage of each band in any specific country.
- g. The blocking levels are valid for channels 1 to 11. (For higher channels, the performance may be lower due to third harmonic signals (3 × 824 MHz) falling within band.)
- h. The minimum and maximum values shown have a 95% confidence level.
- i. -95 dBm with calibration at the time of manufacture, -92 dBm without calibration.

WLAN 2.4 GHz Transmitter Performance Specifications



Note: The specifications in [Table 41](#) include the use of the BCM4339's internal PAs and are specified at the chip port.

Table 41: WLAN 2.4 GHz Transmitter Performance Specifications

Parameter	Condition/Notes		Minimum	Typical	Maximum	Unit
Frequency range	–		2400	–	2500	MHz
Transmitted power in cellular and FM bands (at 18.5 dBm, 100% duty cycle, 1 Mbps CCK) ^a	76–108 MHz	FM RX	–	–148.5	–	dBm/Hz
	776–794 MHz	–	–	–126.5	–	dBm/Hz
	869–960 MHz	cdmaOne, GSM850	–	–162.5	–	dBm/Hz
	925–960 MHz	E-GSM	–	–162.5	–	dBm/Hz
	1570–1580 MHz	GPS	–	–149.5	–	dBm/Hz
	1805–1880 MHz	GSM1800	–	–140.5	–	dBm/Hz
	1930–1990 MHz	GSM1900, cdmaOne, WCDMA	–	–137.5	–	dBm/Hz
	2110–2170 MHz	WCDMA	–	–128.5	–	dBm/Hz
	2500–2570 MHz	Band 7	–	–104.5	–	dBm/Hz
	2300–2400 MHz	Band 40	–	–94.5	–	dBm/Hz
	2570–2620 MHz	Band 38	–	–119.5	–	dBm/Hz
Harmonic level (at 18 dBm with 100% duty cycle)	4.8–5.0 GHz	2nd harmonic	–	–7.5	–	dBm/1 MHz
	7.2–7.5 GHz	3rd harmonic	–	–17.5	–	dBm/1 MHz
<i>EVM Does Not Exceed</i>						
TX power at the chip port for highest power level setting at 25°C and VBAT = 3.6V with spectral mask and EVM compliance ^{b, c}	802.11b (DSSS/CCK)	–9 dB	–	21.5	–	dBm
	OFDM, BPSK	–8 dB	–	20	–	dBm
	OFDM, QPSK	–13 dB	–	20	–	dBm
	OFDM, 16-QAM	–19 dB	–	19	–	dBm
	OFDM, 64-QAM (R = 3/4)	–25 dB	–	19	–	dBm
	OFDM, 64-QAM (MCS7, HT20)	–27 dB	–	19	–	dBm
	OFDM, 256-QAM (MCS8, VHT20)	–30 dB	–	17	–	dBm
	OFDM, 256-QAM (MCS8, VHT40)	–32 dB	–	17	–	dBm
Phase noise	37.4 MHz Crystal, Integrated from 10 kHz to 10 MHz		–	0.45	–	Degrees RMS

Table 41: WLAN 2.4 GHz Transmitter Performance Specifications (Cont.)

Parameter	Condition/Notes	Minimum	Typical	Maximum	Unit
TX power control dynamic range	–	10	–	–	dB
Closed-loop TX power variation at highest power level setting	Across full temperature and voltage range. Applies across 10 dBm to 20 dBm output power range.	–	–	±1.5	dB
Carrier suppression	–	15	–	–	dBc
Gain control step	–	–	0.25	–	dB
Return loss at Chip port TX	$Z_o = 50\Omega$	–	6	–	dB

- The cellular standards listed indicate only typical usages of that band in some countries. Other standards may also be used within those bands.
- Derate by 1.5 dB for temperatures less than -10°C or more than 55°C , or voltages less than 3.0V. Derate by 3.0 dB for voltages of less than 2.7V, or voltages of less than 3.0V at temperatures less than -10°C or greater than 55°C . Derate by 4.5 dB for -40°C to -30°C .
- TX power for Channel 1 and Channel 11 is specified by nonvolatile memory parameters.

WLAN 5 GHz Receiver Performance Specifications



Note: The specifications in [Table 42](#) are specified at the RF port and include the use of an external FEM with LNA from Broadcom's approved-vendor list (AVL), unless otherwise specified. Results with FEMs that are not on Broadcom's AVL are not guaranteed.

Table 42: WLAN 5 GHz Receiver Performance Specifications

Parameter	Condition/Notes	Minimum	Typical	Maximum	Unit
Frequency range	–	4900	–	5845	MHz
RX sensitivity IEEE 802.11a (10% PER for 1000 octet PSDU) ^a	6 Mbps OFDM	–	–94.5	–	dBm
	9 Mbps OFDM	–	–93.1	–	dBm
	12 Mbps OFDM	–	–92.2	–	dBm
	18 Mbps OFDM	–	–89.6	–	dBm
	24 Mbps OFDM	–	–86.3	–	dBm
	36 Mbps OFDM	–	–83	–	dBm
	48 Mbps OFDM	–	–78.3	–	dBm
	54 Mbps OFDM	–	–76.8	–	dBm
RX sensitivity IEEE 802.11n (10% PER for 4096 octet PSDU) ^a	20 MHz channel spacing for all MCS rates				
	MCS0	–	–94	–	dBm
	MCS1	–	–91.7	–	dBm
	MCS2	–	–89.2	–	dBm
Defined for default parameters: 800 ns GI and non-STBC.	MCS3	–	–86.1	–	dBm
	MCS4	–	–82.5	–	dBm
	MCS5	–	–77.9	–	dBm
	MCS6	–	–76.3	–	dBm
	MCS7	–	–74.7	–	dBm
RX sensitivity IEEE 802.11n (10% PER for 4096 octet PSDU) ^a	40 MHz channel spacing for all MCS rates				
	MCS0	–	–91.8	–	dBm
	MCS1	–	–88.9	–	dBm
	MCS2	–	–86.5	–	dBm
Defined for default parameters: 800 ns GI and non-STBC.	MCS3	–	–83.0	–	dBm
	MCS4	–	–79.9	–	dBm
	MCS5	–	–75.2	–	dBm
	MCS6	–	–73.7	–	dBm
	MCS7	–	–72.3	–	dBm

Table 42: WLAN 5 GHz Receiver Performance Specifications (Cont.)

Parameter	Condition/Notes	Minimum	Typical	Maximum	Unit
RX sensitivity IEEE 802.11ac (10% PER for 4096 octet PSDU) ^a Defined for default parameters: 800 ns GI and non-STBC.	20 MHz channel spacing for all MCS rates				
	MCS0	–	–93.3	–	dBm
	MCS1	–	–90.3	–	dBm
	MCS2	–	–87.9	–	dBm
	MCS3	–	–84.9	–	dBm
	MCS4	–	–81.4	–	dBm
	MCS5	–	–76.7	–	dBm
	MCS6	–	–75.1	–	dBm
	MCS7	–	–74.6	–	dBm
RX sensitivity IEEE 802.11ac (10% PER for 4096 octet PSDU) ^a Defined for default parameters: 800 ns GI and non-STBC.	40 MHz channel spacing for all MCS rates				
	MCS0	–	–90.5	–	dBm
	MCS1	–	–87.4	–	dBm
	MCS2	–	–85.3	–	dBm
	MCS3	–	–82.1	–	dBm
	MCS4	–	–79	–	dBm
	MCS5	–	–73.9	–	dBm
	MCS6	–	–72.4	–	dBm
	MCS7	–	–72.3	–	dBm
RX sensitivity IEEE 802.11ac (10% PER for 4096 octet PSDU) ^a Defined for default parameters: 800 ns GI and non-STBC.	80 MHz channel spacing for all MCS rates				
	MCS0	–	–87	–	dBm
	MCS1	–	–83.9	–	dBm
	MCS2	–	–81.9	–	dBm
	MCS3	–	–78.1	–	dBm
	MCS4	–	–75	–	dBm
	MCS5	–	–73	–	dBm
	MCS6	–	–68.5	–	dBm
	MCS7	–	–68.5	–	dBm
MCS8	–	–64.3	–	dBm	
MCS9	–	–62.7	–	dBm	

Table 42: WLAN 5 GHz Receiver Performance Specifications (Cont.)

Parameter	Condition/Notes		Minimum	Typical	Maximum	Unit
RX sensitivity IEEE 802.11ac 20/40/80 MHz channel spacing with LDPC (10% PER for 4096 octet PSDU) at WLAN RF port. Defined for default parameters: 800 ns GI, LDPC coding and non-STBC.	MCS7	20 MHz	–	–76.4	–	dBm
	MCS8	20 MHz	–	–73.7	–	dBm
	MCS7	40 MHz	–	–73.6	–	dBm
	MCS8	40 MHz	–	–70.6	–	dBm
	MCS9	40 MHz	–	–69.1	–	dBm
	MCS7	80 MHz	–	–70.5	–	dBm
	MCS8	80 MHz	–	–67.1	–	dBm
Blocking level for 1 dB RX sensitivity degradation (without external filtering) ^b	776–794 MHz	CDMA2000	–21	–	–	dBm
	824–849 MHz	cdmaOne	–20	–	–	dBm
	824–849 MHz	GSM850	–12	–	–	dBm
	880–915 MHz	E-GSM	–12	–	–	dBm
	1710–1785 MHz	GSM1800	–15	–	–	dBm
	1850–1910 MHz	GSM1800	–15	–	–	dBm
	1850–1910 MHz	cdmaOne	–20	–	–	dBm
	1850–1910 MHz	WCDMA	–21	–	–	dBm
	1920–1980 MHz	WCDMA	–21	–	–	dBm
	2500–2570 MHz	Band 7	–21	–	–	dBm
	2300–2400 MHz	Band 40	–21	–	–	dBm
	2570–2620 MHz	Band 38	–21	–	–	dBm
2545–2575 MHz	XGP Band	–21	–	–	dBm	
Input in-band IP3 ^a	Maximum LNA gain		–	–15.5	–	dBm
	Minimum LNA gain		–	–1.5	–	dBm
Maximum receive level @ 5.24 GHz	@ 6, 9, 12 Mbps		–9.5	–	–	dBm
	@ 18, 24, 36, 48, 54 Mbps		–14.5	–	–	dBm
LPF 3 dB bandwidth	–		9	–	36	MHz
Adjacent channel rejection (Difference between interfering and desired signal (20 MHz apart) at 10% PER for 1000 octet PSDU with desired signal level as specified in Condition/Notes)	6 Mbps OFDM	–79 dBm	16	–	–	dB
	9 Mbps OFDM	–78 dBm	15	–	–	dB
	12 Mbps OFDM	–76 dBm	13	–	–	dB
	18 Mbps OFDM	–74 dBm	11	–	–	dB
	24 Mbps OFDM	–71 dBm	8	–	–	dB
	36 Mbps OFDM	–67 dBm	4	–	–	dB
	48 Mbps OFDM	–63 dBm	0	–	–	dB
	54 Mbps OFDM	–62 dBm	–1	–	–	dB
65 Mbps OFDM	–61 dBm	–2	–	–	dB	

Table 42: WLAN 5 GHz Receiver Performance Specifications (Cont.)

Parameter	Condition/Notes	Minimum	Typical	Maximum	Unit	
Alternate adjacent channel rejection (Difference between interfering and desired signal (40 MHz apart) at 10% PER for 1000 ^c octet PSDU with desired signal level as specified in Condition/Notes)	6 Mbps OFDM	-78.5 dBm	32	-	-	dB
	9 Mbps OFDM	-77.5 dBm	31	-	-	dB
	12 Mbps OFDM	-75.5 dBm	29	-	-	dB
	18 Mbps OFDM	-73.5 dBm	27	-	-	dB
	24 Mbps OFDM	-70.5 dBm	24	-	-	dB
	36 Mbps OFDM	-66.5 dBm	20	-	-	dB
	48 Mbps OFDM	-62.5 dBm	16	-	-	dB
	54 Mbps OFDM	-61.5 dBm	15	-	-	dB
	65 Mbps OFDM	-60.5 dBm	14	-	-	dB
Maximum receiver gain	-	-	95	-	dB	
Gain control step	-	-	3	-	dB	
RSSI accuracy ^d	Range -95 dBm ^e to -30 dBm	-5	-	5	dB	
	Range above -30 dBm	-8	-	8	dB	
Return loss	Z ₀ = 50Ω, across the dynamic range	10	-	13	dB	
Receiver cascaded noise figure	At maximum gain	-	4	6	dB	

- Derate by 1.5 dB for -30°C to -10°C and 55°C to 85°C.
- The cellular standard listed for each band indicates the type of modulation used to generate the interfering signal in that band for the purpose of this test. It is not intended to indicate any specific usage of each band in any specific country.
- For 65 Mbps, the size is 4096.
- The minimum and maximum values shown have a 95% confidence level.
- 95 dBm with calibration at the time of manufacture, -92 dBm without calibration.

WLAN 5 GHz Transmitter Performance Specifications



Note: The specifications in [Table 42](#) include the use of the BCM4339's internal PAs and are specified at the chip port.

Table 43: WLAN 5 GHz Transmitter Performance Specifications

Parameter	Condition/Notes		Minimum	Typical	Maximum	Unit
Frequency range	–		4900	–	5845	MHz
Transmitted power in cellular and FM bands (at 18.5 dBm) ^a	76–108 MHz	FM RX	–	–161.5	–	dBm/Hz
	776–794 MHz	–	–	–161.5	–	dBm/Hz
	869–960 MHz	cdmaOne, GSM850	–	–161.5	–	dBm/Hz
	925–960 MHz	E-GSM	–	–161.5	–	dBm/Hz
	1570–1580 MHz	GPS	–	–161.5	–	dBm/Hz
	1805–1880 MHz	GSM1800	–	–159.5	–	dBm/Hz
	1930–1990 MHz	GSM1900, cdmaOne, WCDMA	–	–161.5	–	dBm/Hz
	2110–2170 MHz	WCDMA	–	–158.5	–	dBm/Hz
	2400–2483 MHz	BT/WLAN	–	–156.5	–	dBm/Hz
	2500–2570 MHz	Band 7	–	–156.5	–	dBm/Hz
	2300–2400 MHz	Band 40	–	–156.5	–	dBm/Hz
	2570–2620 MHz	Band 38	–	–156.5	–	dBm/Hz
	2545–2575 MHz	XGP band	–	–156.5	–	dBm/Hz
Harmonic level (at 17 dBm)	9.8–11.570 GHz	2nd harmonic	–	–30.5	–	dBm/MHz
TX power at the chip port for highest power level setting at 25°C and VBAT = 3.6V with spectral mask and EVM compliance ^{b, c}	OFDM, QPSK	–13 dB	–	21.5	–	dBm
	OFDM, 16-QAM	–19 dB	–	19	–	dBm
	OFDM, 64-QAM (R = 3/4)	–25 dB	–	19	–	dBm
	OFDM, 64-QAM (MCS7, HT20)	–27 dB	–	19	–	dBm
	OFDM, 256-QAM (MCS8, VHT80)	–30 dB	–	17	–	dBm
	OFDM, 256-QAM (MCS9, VHT40 and VHT80)	–32 dB	–	17	–	dBm
Phase noise	37.4 MHz crystal, integrated from 10 kHz to 10 MHz		–	0.45	–	Degrees RMS
TX power control dynamic range	–		10	–	–	dB

Table 43: WLAN 5 GHz Transmitter Performance Specifications (Cont.)

Parameter	Condition/Notes	Minimum	Typical	Maximum	Unit
Closed loop TX power variation at highest power level setting	Across full-temperature and voltage range. Applies across 10 to 20 dBm output power range.	–	–	±2.0	dB
Carrier suppression	–	15	–	–	dBc
Gain control step	–	–	0.25	–	dB
Return loss	$Z_0 = 50\Omega$	–	6	–	dB

- The cellular standards listed indicate only typical usages of that band in some countries. Other standards may also be used within those bands.
- Derate by 1.5 dB for temperatures less than -10°C or more than 55°C , or voltages less than 3.0V. Derate by 3.0 dB for voltages of less than 2.7V, or voltages of less than 3.0V at temperatures less than -10°C or greater than 55°C . Derate by 4.5 dB for -40°C to -30°C .
- TX power for Channel 1 and Channel 11 is specified by non-volatile memory parameters.

General Spurious Emissions Specifications

Table 44: General Spurious Emissions Specifications

Parameter	Condition/Notes	Min.	Typ.	Max.	Unit
Frequency range	–	2400	–	2500	MHz
General Spurious Emissions					
TX emissions	30 MHz < f < 1 GHz RBW = 100 kHz	–	–93	–	dBm
	1 GHz < f < 12.75 GHz RBW = 1 MHz	–	–45.5	–	dBm
	1.8 GHz < f < 1.9 GHz RBW = 1 MHz	–	–72	–	dBm
	5.15 GHz < f < 5.3 GHz RBW = 1 MHz	–	–87	–	dBm
RX/standby emissions	30 MHz < f < 1 GHz RBW = 100 kHz	–	–107	–	dBm
	1 GHz < f < 12.75 GHz RBW = 1 MHz	–	–65 ^a	–	dBm
	1.8 GHz < f < 1.9 GHz RBW = 1 MHz	–	–87	–	dBm
	5.15 GHz < f < 5.3 GHz RBW = 1 MHz	–	–100	–	dBm

- The value presented in this table is the result of LO leakage at $3/2 * f_c$ for 2.4 GHz or $2/3 * f_c$ for 5 GHz (where f_c is the carrier frequency). For all other emissions in this range, the value is -96 dBm.

Section 18: Internal Regulator Electrical Specifications

Functional operation is not guaranteed outside of the specification limits provided in this section.

Core Buck Switching Regulator

Table 45: Core Buck Switching Regulator (CBUCK) Specifications

Specification	Notes	Min.	Typ.	Max.	Units
Input supply voltage (DC)	DC voltage range inclusive of disturbances.	3.0	3.6	5.25 ^a	V
PWM mode switching frequency	CCM, Load > 100 mA VBAT = 3.6V	2.8	4	5.2	MHz
PWM output current	–	–	–	600	mA
Output current limit	–	–	1400	–	mA
Output voltage range	Programmable, 30 mV steps Default = 1.35V	1.2	1.35	1.5	V
PWM output voltage DC accuracy	Includes load and line regulation. Forced PWM mode	–4	–	4	%
PWM ripple voltage, static	Measure with 20 MHz bandwidth limit. Static Load. Max. Ripple based on VBAT = 3.6V, Vout = 1.35V, Fsw = 4 MHz, 2.2 μ H inductor L > 1.05 μ H, Cap + Board total-ESR < 20 m Ω , C _{out} > 1.9 μ F, ESL < 200pH	–	7	20	mVpp
PWM mode peak efficiency	Peak Efficiency at 200 mA load	78	86	–	%
PFM mode efficiency	10 mA load current	70	81	–	%
Start-up time from power down	VIO already ON and steady. Time from REG_ON rising edge to CLDO reaching 1.2V	–	–	850	μ s
External inductor	0806 size, \pm 30%, 0.11 \pm 25% Ohms	–	2.2	–	μ H
External output capacitor	Ceramic, X5R, 0402, ESR < 30 m Ω at 4 MHz, \pm 20%, 6.3V	2.0 ^b	4.7	10 ^c	μ F
External input capacitor	For SR_VDDBATP5V pin, ceramic, X5R, 0603, ESR < 30 m Ω at 4 MHz, \pm 20%, 6.3V, 4.7 μ F	0.67 ^b	4.7	–	μ F

Table 45: Core Buck Switching Regulator (CBUCK) Specifications (Cont.)

Specification	Notes	Min.	Typ.	Max.	Units
Input supply voltage ramp-up time	0 to 4.3V	40	–	–	μs
<p>a. The maximum continuous voltage is 5.25V. Voltage transients up to 6.0V (for up to 10 seconds), cumulative duration over the lifetime of the device, are allowed. Voltage transients as high as 5.5V (for up to 250 seconds), cumulative duration over the lifetime of the device, are allowed.</p> <p>b. Minimum capacitor value refers to the residual capacitor value after taking into account the part-to-part tolerance, DC-bias, temperature, and aging.</p> <p>c. Total capacitance includes those connected at the far end of the active load.</p>					

3.3V LDO (LDO3P3)

Table 46: LDO3P3 Specifications

Specification	Notes	Min.	Typ.	Max.	Units
Input supply voltage, V_{in}	Min. = $V_o + 0.2V = 3.5V$ dropout voltage requirement must be met under maximum load for performance specifications.	3.0	3.6	5.25 ^a	V
Output current	–	0.001	–	450	mA
Nominal output voltage, V_o	Default = 3.3V	–	3.3	–	V
Dropout voltage	At max load.	–	–	200	mV
Output voltage DC accuracy	Includes line/load regulation.	–5	–	+5	%
Quiescent current	No load	–	–	100	μA
Line regulation	V_{in} from ($V_o + 0.2V$) to 4.8V, max load	–	–	3.5	mV/V
Load regulation	load from 1 mA to 450 mA	–	–	0.3	mV/mA
PSRR	$V_{in} \geq V_o + 0.2V$, $V_o = 3.3V$, $C_o = 4.7 \mu F$, Max. load, 100 Hz to 100 kHz	20	–	–	dB
LDO turn-on time	Chip already powered up.	–	160	250	μs
External output capacitor, C_o	Ceramic, X5R, 0402, (ESR: 5 mΩ–240 mΩ), ± 10%, 10V	1.0 ^b	4.7	10	μF
External input capacitor	For SR_VDDBATA5V pin (shared with Bandgap) Ceramic, X5R, 0402, (ESR: 30m-200 mΩ), ± 10%, 10V. Not needed if sharing VBAT capacitor 4.7 μF with SR_VDDBATP5V.	–	4.7	–	μF

- a. The maximum continuous voltage is 5.25V. Voltage transients up to 6.0V (for up to 10 seconds), cumulative duration over the lifetime of the device, are allowed. Voltage transients as high as 5.5V (for up to 250 seconds), cumulative duration over the lifetime of the device, are allowed.
- b. Minimum capacitor value refers to the residual capacitor value after taking into account the part-to-part tolerance, DC-bias, temperature, and aging.

2.5V LDO (BTLDO2P5)

Table 47: BTLDO2P5 Specifications

Specification	Notes	Min.	Typ.	Max.	Units
Input supply voltage	Min. = 2.5V + 0.2V = 2.7V. Dropout voltage requirement must be met under maximum load for performance specifications.	3.0	3.6	5.25 ^a	V
Nominal output voltage	Default = 2.5V.	–	2.5	–	V
Output voltage programmability	Range	2.2	2.5	2.8	V
	Accuracy at any step (including line/load regulation), load > 0.1 mA.	–5	–	5	%
Dropout voltage	At maximum load.	–	–	200	mV
Output current	–	0.1	–	70	mA
Quiescent current	No load.	–	8	16	μA
	Maximum load at 70 mA.	–	660	700	μA
Leakage current	Power-down mode.	–	1.5	5	μA
Line regulation	V _{in} from (V _o + 0.2V) to 4.8V, maximum load.	–	–	3.5	mV/V
Load regulation	Load from 1 mA to 70 mA, V _{in} = 3.6V.	–	–	0.3	mV/mA
PSRR	V _{in} ≥ V _o + 0.2V, V _o = 2.5V, C _o = 2.2 μF, 20 maximum load, 100 Hz to 100 kHz.	–	–	–	dB
LDO turn-on time	Chip already powered up.	–	–	150	μs
In-rush current	V _{in} = V _o + 0.15V to 4.8V, C _o = 2.2 μF, No load.	–	–	250	mA
External output capacitor, C _o	Ceramic, X5R, 0402, (ESR: 5–240 mΩ), ±10%, 10V	0.7 ^b	2.2	2.64	μF
External input capacitor	For SR_VDDBATA5V pin (shared with Bandgap) ceramic, X5R, 0402, (ESR: 30–200 mΩ), ±10%, 10V. Not needed if sharing VBAT 4.7 μF capacitor with SR_VDDBATP5V.	–	4.7	–	μF

- The maximum continuous voltage is 5.25V. Voltage transients up to 6.0V (for up to 10 seconds), cumulative duration over the lifetime of the device, are allowed. Voltage transients as high as 5.5V (for up to 250 seconds), cumulative duration over the lifetime of the device, are allowed.
- The minimum value refers to the residual capacitor value after taking into account part-to-part tolerance, DC-bias, temperature, and aging.

CLDO

Table 48: CLDO Specifications

Specification	Notes	Min.	Typ.	Max.	Units
Input supply voltage, V_{in}	Min. = $1.2 + 0.15V = 1.35V$ dropout voltage requirement must be met under maximum load.	1.3	1.35	1.5	V
Output current	–	0.2	–	300	mA
Output voltage, V_o	Programmable in 25 mV steps. Default = 1.2.V	1.1	1.2	1.275	V
Dropout voltage	At max. load	–	–	150	mV
Output voltage DC accuracy	Includes line/load regulation	–4	–	+4	%
Quiescent current	No load	–	24	–	μA
	300 mA load	–	2.1	–	mA
Line regulation	V_{in} from ($V_o + 0.15V$) to 1.5V, maximum load	–	–	5	mV/V
Load regulation	Load from 1 mA to 300 mA	–	0.02	0.05	mV/mA
Leakage current	Power down	–	–	20	μA
	Bypass mode	–	1	3	μA
PSRR	@1 kHz, $V_{in} \geq 1.35V$, $C_o = 4.7 \mu F$	20	–	–	dB
Start-up time of PMU	VIO up and steady. Time from the REG_ON rising edge to the CLDO reaching 1.2V.	–	–	700	μs
LDO turn-on time	LDO turn-on time when rest of the chip is up	–	140	180	μs
External output capacitor, C_o	Total ESR: 5 m Ω –240 m Ω	1.32 ^a	4.7	–	μF
External input capacitor	Only use an external input capacitor at the VDD_LDO pin if it is not supplied from CBUCK output.	–	1	2.2	μF

- a. Minimum capacitor value refers to the residual capacitor value after taking into account the part-to-part tolerance, DC-bias, temperature, and aging.

LNLDO

Table 49: LNLDO Specifications

Specification	Notes	Min.	Typ.	Max.	Units
Input supply voltage, V_{in}	Min. = $1.2V_o + 0.15V = 1.35V$ dropout voltage requirement must be met under maximum load.	1.3	1.35	1.5	V
Output current	–	0.1	–	150	mA
Output voltage, V_o	Programmable in 25 mV steps. Default = 1.2V	1.1	1.2	1.275	V
Dropout voltage	At maximum load	–	–	150	mV
Output voltage DC accuracy	Includes line/load regulation	–4	–	+4	%
Quiescent current	No load	–	44	–	μA
	Max. load	–	970	990	μA
Line regulation	V_{in} from ($V_o + 0.1V$) to 1.5V, max load	–	–	5	mV/V
Load regulation	Load from 1 mA to 150 mA	–	0.02	0.05	mV/mA
Leakage current	Power-down	–	–	10	μA
Output noise	@30 kHz, 60–150 mA load $C_o = 2.2 \mu F$	–	–	60	nV/rt Hz
	@100 kHz, 60–150 mA load $C_o = 2.2 \mu F$	–	–	35	nV/rt Hz
PSRR	@ 1kHz, Input > 1.35V, $C_o = 2.2 \mu F$, $V_o = 1.2V$	20	–	–	dB
LDO turn-on time	LDO turn-on time when rest of chip is up	–	140	180	μs
External output capacitor, C_o	Total ESR (trace/capacitor): 5 m Ω –240 m Ω	0.5 ^a	2.2	4.7	μF
External input capacitor	Only use an external input capacitor at the VDD_LDO pin if it is not supplied from CBU \bar{C} K output. Total ESR (trace/capacitor): 30 m Ω –200 m Ω	–	1	2.2	μF

- a. Minimum capacitor value refers to the residual capacitor value after taking into account the part-to-part tolerance, DC-bias, temperature, and aging.

Section 19: System Power Consumption



Note: Unless otherwise stated, these values apply for the conditions specified in [Table 33: “Recommended Operating Conditions and DC Characteristics,”](#) on page 124.

WLAN Current Consumption

[Table 50](#) shows the typical, total current consumed by the BCM4339. To calculate total-solution current consumption for designs using external PAs, LNAs, and/or FEMs, add the current consumption of the external devices to the numbers in [Table 50](#).

All values in [Table 50](#) are with the Bluetooth core in reset (that is, with Bluetooth and FM off).

Table 50: Typical WLAN Current Consumption (BCM4339 Current Only)

Mode	Bandwidth (MHz)	Band (GHz)	VBAT = 3.6V, VDDIO = 1.8V, T _A 25°C	
			Vbat, mA	Vio ^a , μA
Sleep Modes				
OFF ^b	–	–	0.005	5
SLEEP ^c	–	–	0.005	150
IEEE Power Save, DTIM 1 ^d	–	2.4	0.850	150
IEEE Power Save, DTIM 3 ^d	–	2.4	0.350	150
IEEE Power Save, DTIM 1 ^d	–	5	0.550	150
IEEE Power Save, DTIM 3 ^d	–	5	0.300	150
Active Modes				
Receive ^{e,f} MCS8 (SGI)	20	2.4	50	5
CRS ^g	20	2.4	46	5
Receive ^{e,f} MCS7 (SGI)	20	5	66	5
CRS ^g	20	5	56	5
Receive ^{e,f} MCS7 (SGI)	40	5	79.5	5
CRS ^g	40	5	67	5
Receive ^{e,f} MCS9 (SGI)	80	5	110	5
CRS ^g	80	5	103	5

Table 50: Typical WLAN Current Consumption (BCM4339 Current Only) (Cont.)

Mode	Bandwidth (MHz)	Band (GHz)	VBAT = 3.6V, VDDIO = 1.8V, T _A 25°C	
			Vbat, mA	Vio ^a , μA
Active Modes with External PAs (TX Output Power is -5 dBm at the Chip Port)				
Transmit, CCK	20	2.4	88	5
Transmit, MCS8, HT20, SGI ^{e, h}	20	2.4	76	5
Transmit, MCS7, SGI ^{e, h}	20	5	111	5
Transmit, MCS7 ^{e, h}	40	5	125	5
Transmit, MCS9, SGI ^{e, h}	40	5	125	5
Transmit, MCS9, SGI ^{e, h}	80	5	147	5
Active Modes with Internal PAs (TX Output Power Measured at the Chip Port)				
TX CCK 11 Mbps at 21.7 dBm	20	2.4	325	5
TX OFDM MCS8 (SGI) at 17.2 dBm	20	2.4	240	5
TX OFDM MCS7 (SGI) at 18.5 dBm	20	5	280	5
TX OFDM MCS7 at 18.7 dBm	40	5	340	5
TX OFDM MCS9 (SGI) at 16.2 dBm	40	5	270	5
TX OFDM MCS9 (SGI) at 15.7 dBm	80	5	270	5

- a. VIO is specified with all pins idle (not switching) and not driving any loads.
- b. WL_REG_ON, BT_REG_ON low.
- c. Idle, not associated, or inter-beacon.
- d. Beacon Interval = 102.4 ms. Beacon duration = 1 ms @1 Mbps. Average current over the specified DTIM intervals.
- e. Measured using packet engine test mode.
- f. Duty cycle is 100%. Carrier sense (CS) detect/packet receive.
- g. Carrier sense (CCA) when no carrier present.
- h. Duty cycle is 100%. Excludes external PA contribution.

Bluetooth and FM Current Consumption

The Bluetooth, BLE, and FM Bluetooth BLE current consumption measurements are shown in [Table 51](#).



Note:

- The WLAN core is in reset (WLAN_REG_ON = low) for all measurements provided in [Table 51](#).
- For FM measurements, the Bluetooth core is in Sleep mode.
- The BT current consumption numbers are measured based on GFSK TX output power = 10 dBm.

Table 51: Bluetooth BLE and FM Current Consumption

Operating Mode	VBAT (VBAT = 3.6V) Typical	VDDIO (VDDIO = 1.8V) Typical	Units
Sleep	10	225	μA
Standard 1.28s Inquiry Scan	180	235	μA
P and I Scan ^b	320	235	μA
500 ms Sniff Master	170	250	μA
500 ms Sniff Slave	120	250	μA
DM1/DH1 Master	22.81	0.034	mA
DM3/DH3 Master	28.06	0.044	mA
DM5/DH5 Master	29.01	0.047	mA
3DH5 Master	27.09	0.100	mA
SCO HV3 Master	7.9	0.123	mA
HV3 + Sniff + Scan ^a	11.38	0.180	mA
FMRX I ² S Audio	8.64	0.022	mA
FMRX Analog Audio only	9.15	0.022	mA
FMRX I ² S Audio + RDS	8.65	0.022	mA
FMRX Analog Audio + RDS	9.20	0.022	mA
BLE Scan ^b	175	235	μA
BLE Scan 10 ms	14.09	0.022	mA
BLE Adv – Unconnectable 1.00 sec	69	245	μA
BLE Adv – Unconnectable 1.28 sec	67	235	μA
BLE Adv – Unconnectable 2.00 sec	42	240	μA
BLE Connected 7.5 ms	4.30	0.020	mA
BLE Connected 1 sec	53	240	μA
BLE Connected 1.28 sec	48	240	μA

- a. At maximum class 1 TX power, 500 ms sniff, four attempts (slave), P = 1.28s, and I = 2.56s.
 b. No devices present. A 1.28 second interval with a scan window of 11.25 ms.

Section 20: Interface Timing and AC Characteristics

SDIO/gSPI Timing

SDIO Default Mode Timing

SDIO default mode timing is shown by the combination of [Figure 43](#) and [Table 52](#).

Figure 43: SDIO Bus Timing (Default Mode)

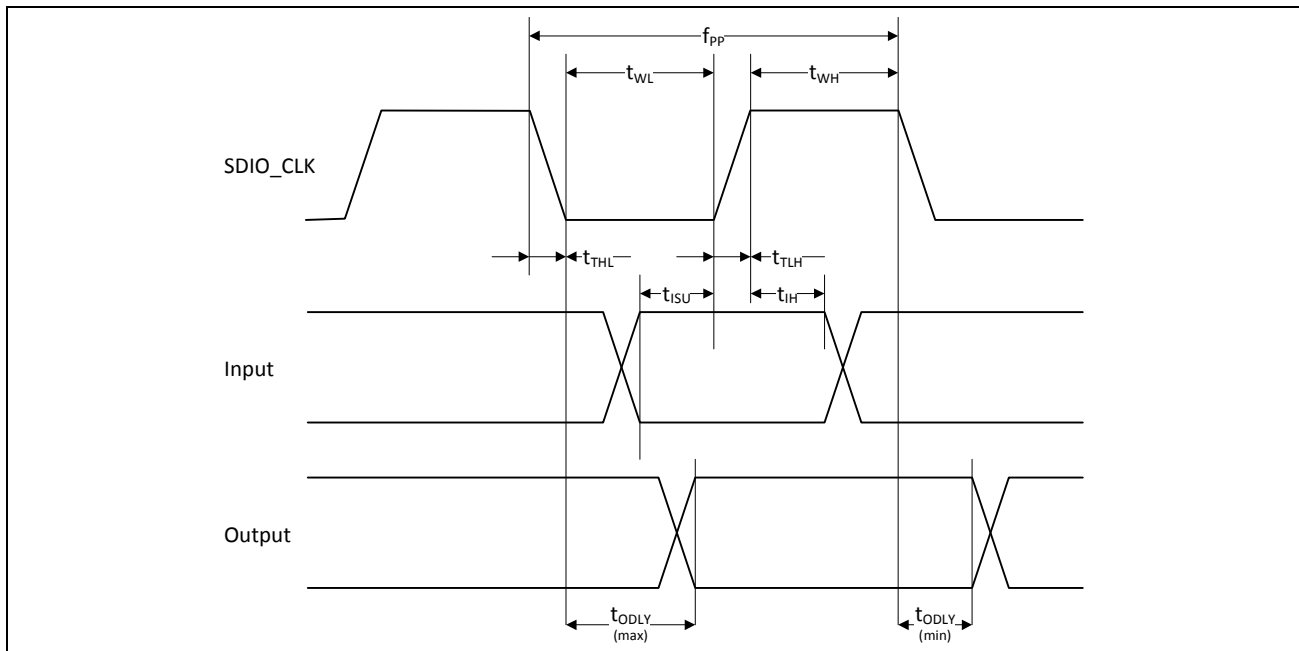

Table 52: SDIO Bus Timing^a Parameters (Default Mode)

Parameter	Symbol	Minimum	Typical	Maximum	Unit
SDIO CLK (All values are referred to minimum V_{IH} and maximum V_{IL}^b)					
Frequency – Data Transfer mode	f_{PP}	0	–	25	MHz
Frequency – Identification mode	f_{OD}	0	–	400	kHz
Clock low time	t_{WL}	10	–	–	ns
Clock high time	t_{WH}	10	–	–	ns
Clock rise time	t_{TLH}	–	–	10	ns
Clock fall time	t_{THL}	–	–	10	ns
Inputs: CMD, DAT (referenced to CLK)					

Table 52: SDIO Bus Timing^a Parameters (Default Mode) (Cont.)

Parameter	Symbol	Minimum	Typical	Maximum	Unit
Input setup time	tISU	5	–	–	ns
Input hold time	tIH	5	–	–	ns
Outputs: CMD, DAT (referenced to CLK)					
Output delay time – Data Transfer mode	tODLY	0	–	14	ns
Output delay time – Identification mode	tODLY	0	–	50	ns

- a. Timing is based on $CL \leq 40\text{pF}$ load on CMD and Data.
b. Min. (V_{ih}) = $0.7 \times V_{DDIO}$ and max (V_{il}) = $0.2 \times V_{DDIO}$.

SDIO High-Speed Mode Timing

SDIO high-speed mode timing is shown by the combination of Figure 44 and Table 53.

Figure 44: SDIO Bus Timing (High-Speed Mode)

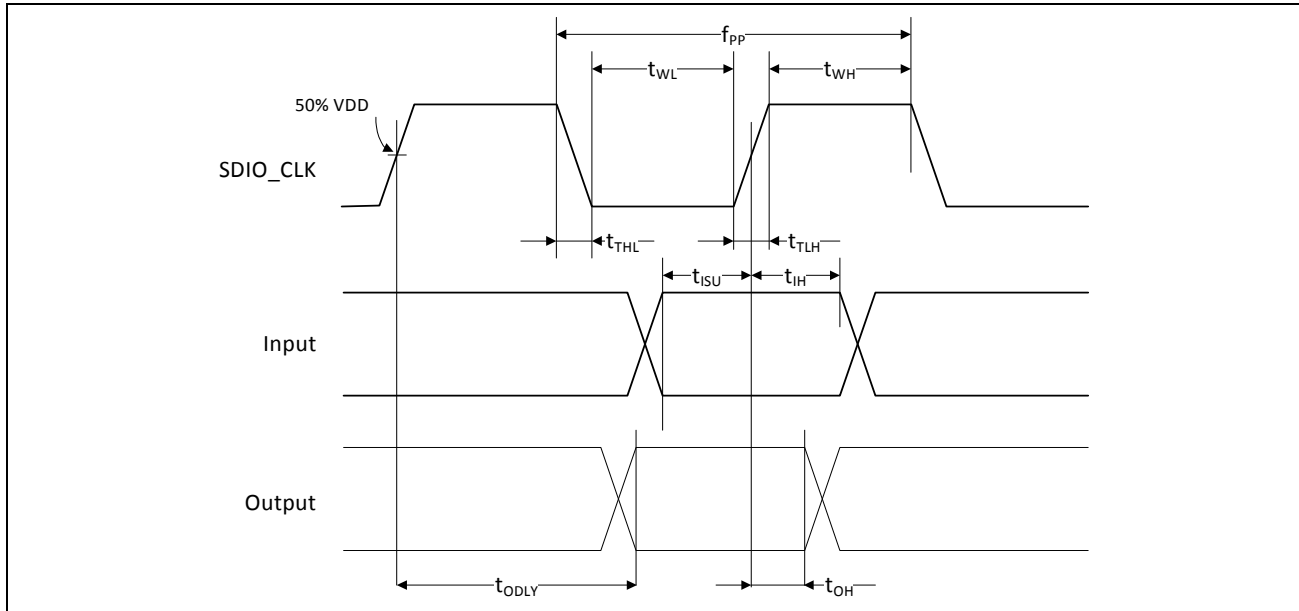

Table 53: SDIO Bus Timing^a Parameters (High-Speed Mode)

Parameter	Symbol	Minimum	Typical	Maximum	Unit
SDIO CLK (all values are referred to minimum VIH and maximum VIL^b)					
Frequency – Data Transfer Mode	fPP	0	–	50	MHz
Frequency – Identification Mode	fOD	0	–	400	kHz
Clock low time	tWL	7	–	–	ns
Clock high time	tWH	7	–	–	ns
Clock rise time	tTLH	–	–	3	ns
Clock fall time	tTHL	–	–	3	ns
Inputs: CMD, DAT (referenced to CLK)					
Input setup time	tISU	6	–	–	ns
Input hold time	tIH	2	–	–	ns
Outputs: CMD, DAT (referenced to CLK)					
Output delay time – Data Transfer Mode	tODLY	–	–	14	ns
Output hold time	tOH	2.5	–	–	ns
Total system capacitance (each line)	CL	–	–	40	pF

a. Timing is based on $CL \leq 40\text{pF}$ load on CMD and Data.
 b. Min. (Vih) = $0.7 \times VDDIO$ and max (Vil) = $0.2 \times VDDIO$.

SDIO Bus Timing Specifications in SDR Modes

Clock Timing

Figure 45: SDIO Clock Timing (SDR Modes)

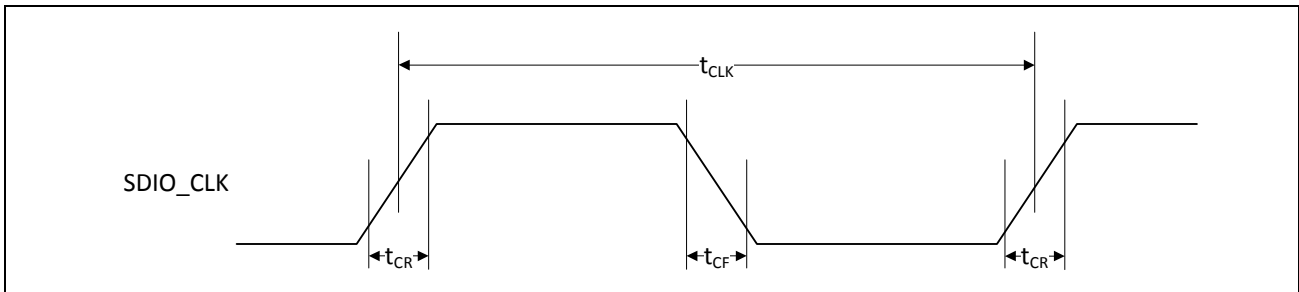

Table 54: SDIO Bus Clock Timing Parameters (SDR Modes)

Parameter	Symbol	Minimum	Maximum	Unit	Comments
–	t_{CLK}	40	–	ns	SDR12 mode
		20	–	ns	SDR25 mode
		10	–	ns	SDR50 mode
		4.8	–	ns	SDR104 mode
–	t_{CR}, t_{CF}	–	$0.2 \times t_{CLK}$	ns	$t_{CR}, t_{CF} < 2.00$ ns (max.) @100 MHz, $C_{CARD} = 10$ pF $t_{CR}, t_{CF} < 0.96$ ns (max.) @208 MHz, $C_{CARD} = 10$ pF
Clock duty cycle	–	30	70	%	–

Device Input Timing

Figure 46: SDIO Bus Input Timing (SDR Modes)

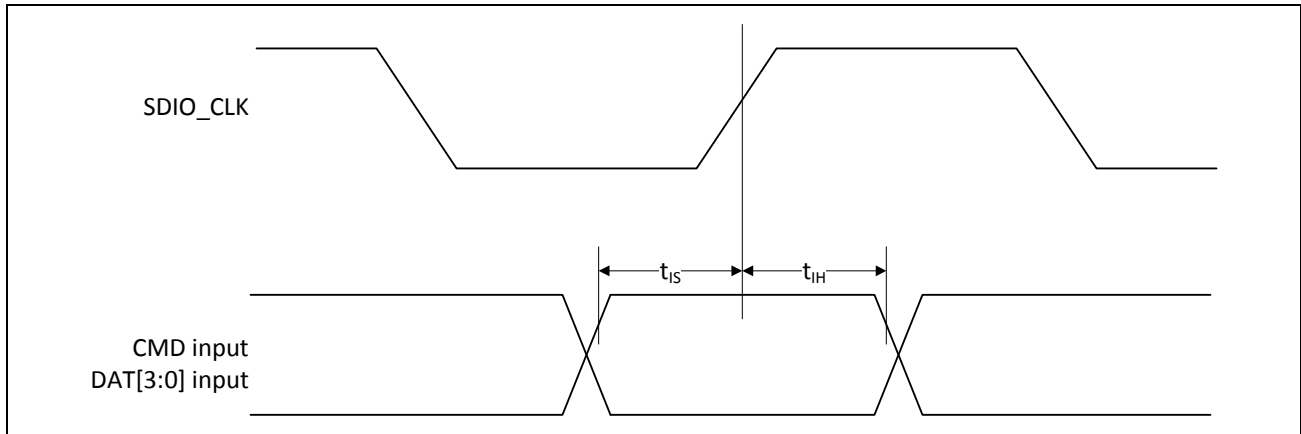

Table 55: SDIO Bus Input Timing Parameters (SDR Modes)

Symbol	Minimum	Maximum	Unit	Comments
SDR104 Mode				
t_{IS}	1.4	–	ns	$C_{CARD} = 10 \text{ pF}$, $V_{CT} = 0.975\text{V}$
t_{IH}	0.8	–	ns	$C_{CARD} = 5 \text{ pF}$, $V_{CT} = 0.975\text{V}$
SDR50 Mode				
t_{IS}	3.0	–	ns	$C_{CARD} = 10 \text{ pF}$, $V_{CT} = 0.975\text{V}$
t_{IH}	0.8	–	ns	$C_{CARD} = 5 \text{ pF}$, $V_{CT} = 0.975\text{V}$
SDR25 Mode				
t_{IS}	3.0	–	ns	$C_{CARD} = 10 \text{ pF}$, $V_{CT} = 0.975\text{V}$
t_{IH}	0.8	–	ns	$C_{CARD} = 5 \text{ pF}$, $V_{CT} = 0.975\text{V}$
SDR12 Mode				
t_{IS}	3.0	–	ns	$C_{CARD} = 10 \text{ pF}$, $V_{CT} = 0.975\text{V}$
t_{IH}	0.8	–	ns	$C_{CARD} = 5 \text{ pF}$, $V_{CT} = 0.975\text{V}$

Device Output Timing

Figure 47: SDIO Bus Output Timing (SDR Modes up to 100 MHz)

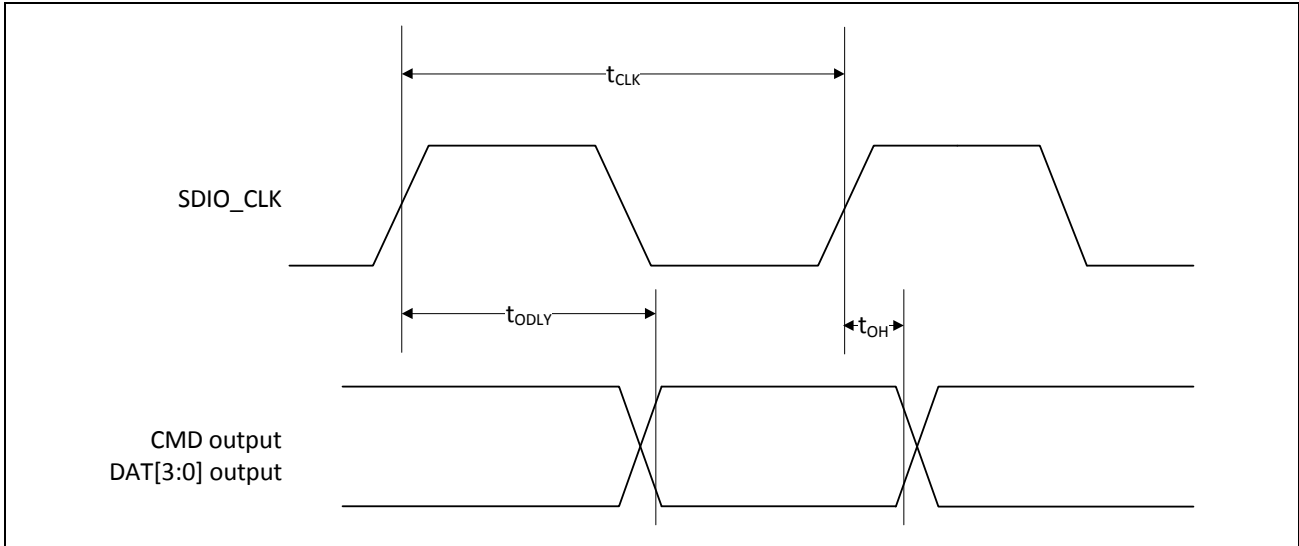

Table 56: SDIO Bus Output Timing Parameters (SDR Modes up to 100 MHz)

Symbol	Minimum	Maximum	Unit	Comments
t_{ODLY}	–	7.5	ns	$t_{CLK} \geq 10$ ns $C_L = 30$ pF using driver type B for SDR50
t_{ODLY}	–	14.0	ns	$t_{CLK} \geq 20$ ns $C_L = 40$ pF using for SDR12, SDR25
t_{OH}	1.5	–	ns	Hold time at the t_{ODLY} (min) $C_L = 15$ pF

Figure 48: SDIO Bus Output Timing (SDR Modes 100 MHz to 208 MHz)

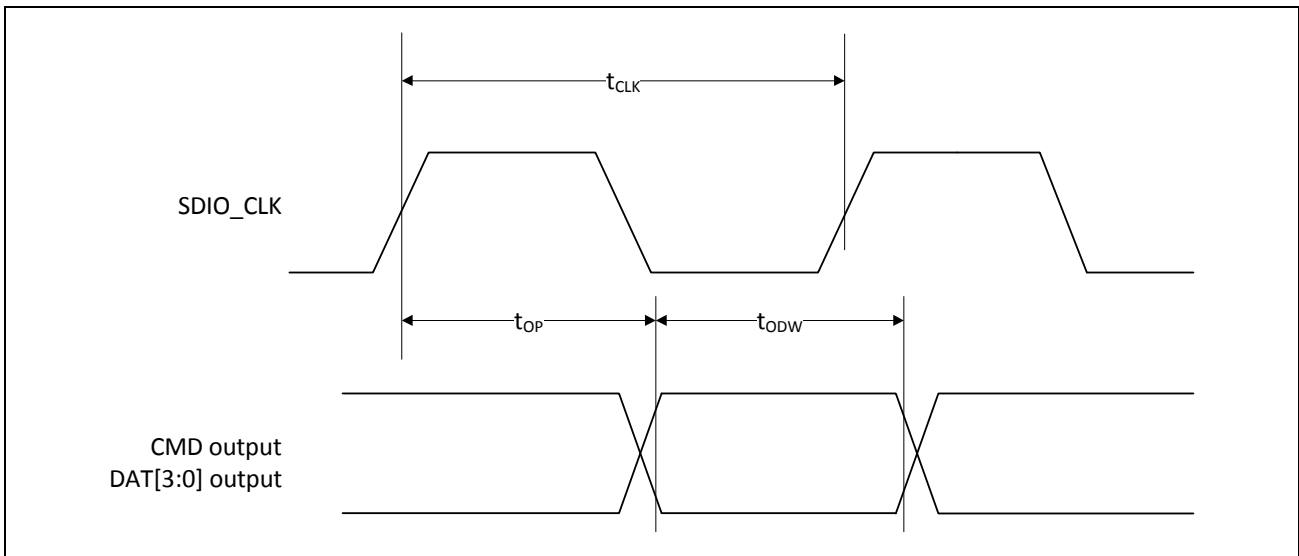
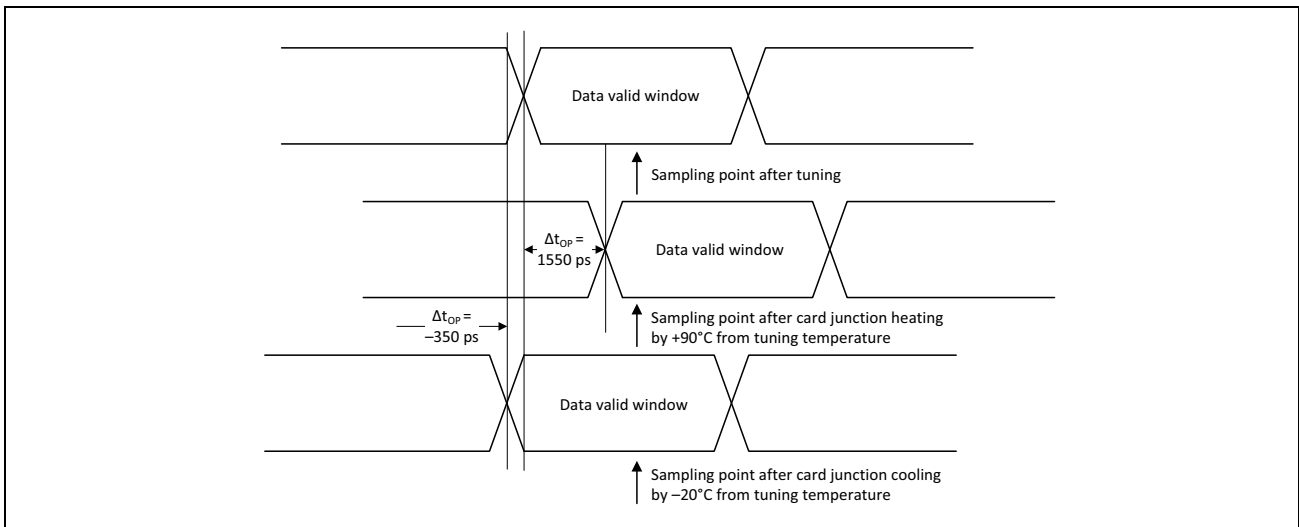

Table 57: SDIO Bus Output Timing Parameters (SDR Modes 100 MHz to 208 MHz)

Symbol	Minimum	Maximum	Unit	Comments
t_{OP}	0	2	UI	Card output phase
Δt_{OP}	-350	+1550	ps	Delay variation due to temp change after tuning
t_{ODW}	0.60	-	UI	$t_{ODW}=2.88$ ns @208 MHz

- $\Delta t_{OP} = +1550$ ps for junction temperature of $\Delta t_{OP} = 90$ degrees during operation
- $\Delta t_{OP} = -350$ ps for junction temperature of $\Delta t_{OP} = -20$ degrees during operation
- $\Delta t_{OP} = +2600$ ps for junction temperature of $\Delta t_{OP} = -20$ to $+125$ degrees during operation

Figure 49: Δt_{OP} Consideration for Variable Data Window (SDR 104 Mode)



SDIO Bus Timing Specifications in DDR50 Mode

Figure 50: SDIO Clock Timing (DDR50 Mode)

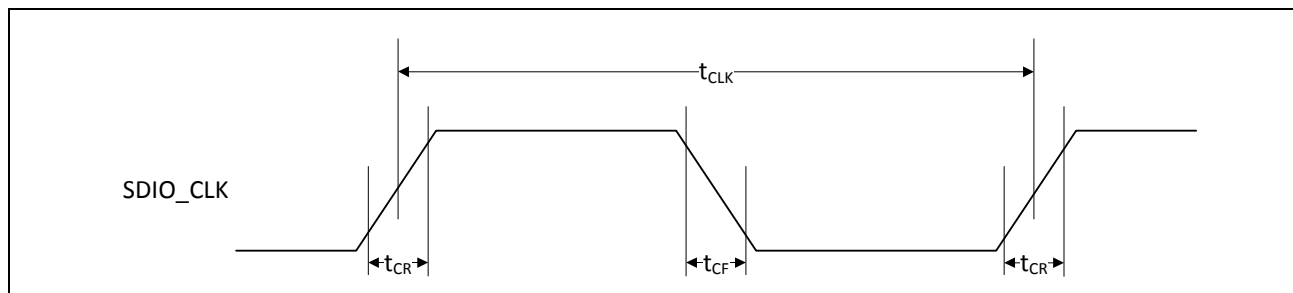

Table 58: SDIO Bus Clock Timing Parameters (DDR50 Mode)

Parameter	Symbol	Minimum	Maximum	Unit	Comments
–	t_{CLK}	20	–	ns	DDR50 mode
–	t_{CR}, t_{CF}	–	$0.2 \times t_{CLK}$	ns	$t_{CR}, t_{CF} < 4.00$ ns (max) @50 MHz, $C_{CARD} = 10$ pF
Clock duty cycle	–	45	55	%	–

Data Timing, DDR50 Mode

Figure 51: SDIO Data Timing (DDR50 Mode)

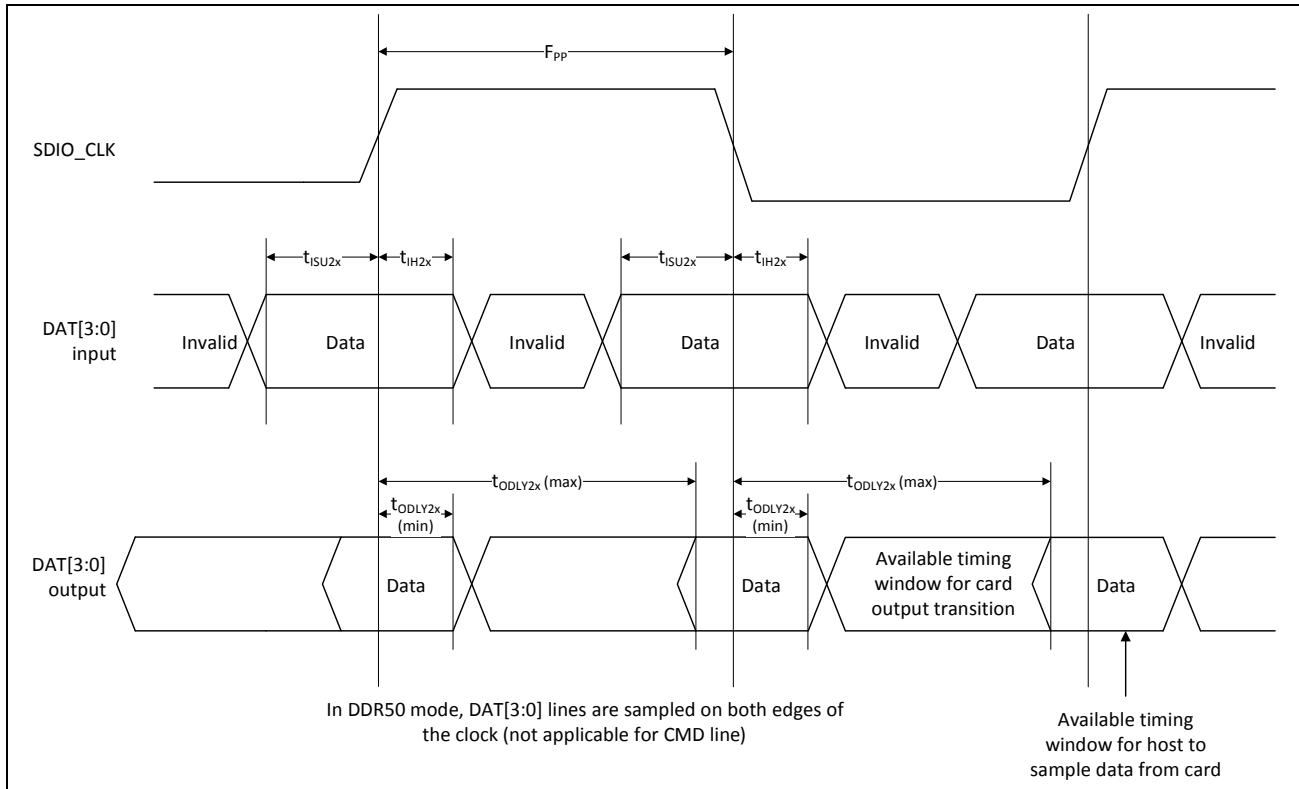

Table 59: SDIO Bus Timing Parameters (DDR50 Mode)

Parameter	Symbol	Minimum	Maximum	Unit	Comments
Input CMD					
Input setup time	t_{ISU}	6	–	ns	$C_{CARD} < 10\text{pF}$ (1 Card)
Input hold time	t_{IH}	0.8	–	ns	$C_{CARD} < 10\text{pF}$ (1 Card)
Output CMD					
Output delay time	t_{ODLY}	–	13.7	ns	$C_{CARD} < 30\text{pF}$ (1 Card)
Output hold time	t_{OH}	1.5	–	ns	$C_{CARD} < 15\text{pF}$ (1 Card)
Input DAT					
Input setup time	t_{ISU2x}	3	–	ns	$C_{CARD} < 10\text{pF}$ (1 Card)
Input hold time	t_{IH2x}	0.8	–	ns	$C_{CARD} < 10\text{pF}$ (1 Card)
Output DAT					
Output delay time	t_{ODLY2x}	–	7.0	ns	$C_{CARD} < 25\text{pF}$ (1 Card)
Output hold time	t_{ODLY2x}	1.5	–	ns	$C_{CARD} < 15\text{pF}$ (1 Card)

gSPI Signal Timing

The gSPI host and device always use the rising edge of clock to sample data.

Figure 52: gSPI Timing

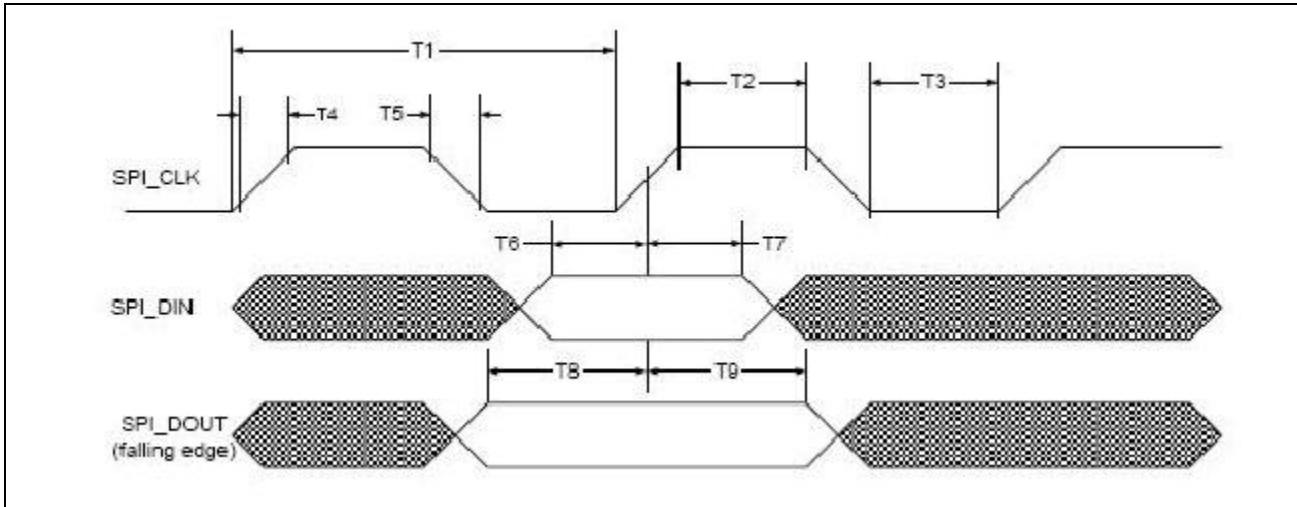

Table 60: gSPI Timing Parameters

Parameter	Symbol	Minimum	Maximum	Units	Note
Clock period	T1	20.8	–	ns	$F_{max} = 48 \text{ MHz}$
Clock high/low	T2/T3	$(0.45 \times T1) - T4$	$(0.55 \times T1) - T4$	ns	–
Clock rise/fall time ^a	T4/T5	–	2.5	ns	Measured from 10% to 90% of VDDIO
Input setup time	T6	5.0	–	ns	Setup time, SIMO valid to SPI_CLK active edge
Input hold time	T7	5.0	–	ns	Hold time, SPI_CLK active edge to SIMO invalid
Output setup time	T8	5.0	–	ns	Setup time, SOMI valid before SPI_CLK rising
Output hold time	T9	5.0	–	ns	Hold time, SPI_CLK active edge to SOMI invalid
CSX to clock ^b	–	7.86	–	ns	CSX fall to 1st rising edge
Clock to CSX ^a	–	–	–	ns	Last falling edge to CSX high

- a. Limit applies when $\text{SPI_CLK} = F_{max}$. For slower clock speeds, longer rise/fall times are acceptable provided that the transitions are monotonic and the setup and hold time limits are complied with.
- b. SPI_CSx remains active for entire duration of gSPI read/write/write-read transaction (overall words for multiple-word transaction).

PCI Express Interface Parameters

Table 61: PCI Express Interface Parameters

Parameter	Symbol	Comments	Minimum	Typical	Maximum	Unit
General						
Baud rate	BPS	–	–	5	–	Gbaud
Reference clock amplitude	Vref	LVPECL, AC coupled	1	–	–	V
Receiver						
Differential termination	ZRX-DIFF-DC	Differential termination	80	100	120	Ω
DC impedance	ZRX-DC	DC common-mode impedance	40	50	60	Ω
Powered down termination (POS)	ZRX-HIGH-IMP-DC-POS	Power-down or RESET high impedance	100k	–	–	Ω
Powered down termination (NEG)	ZRX-HIGH-IMP-DC-NEG	Power-down or RESET high impedance	1k	–	–	Ω
Input voltage	VRX-DIFFp-p	AC coupled, differential p-p	175	–	–	mV
Jitter tolerance	TRX-EYE	Minimum receiver eye width	0.4	–	–	UI
Differential return loss	RLRX-DIFF	Differential return loss	10	–	–	dB
Common-mode return loss	RLRX-CM	Common-mode return loss	6	–	–	dB
Unexpected electrical idle enter detect threshold integration time	TRX-IDEL-DET-DIFF-ENTERTIME	An unexpected electrical idle must be recognized no longer than this time to signal an unexpected idle condition.	–	–	10	ms
Signal detect threshold	VRX-IDLE-DET-DIFFp-p	Electrical idle detect threshold	65	–	175	mV
Transmitter						
Output voltage	VTX-DIFFp-p	Differential p-p, programmable in 16 steps	0.8	–	1200	mV
Output voltage rise time	VTX-RISE	20% to 80%	0.125 (2.5 GT/s) 0.15 (5 GT/s)	–	–	UI
Output voltage fall time	VTX-FALL	80% to 20%	0.125 (2.5 GT/s) 0.15 (5 GT/s)	–	–	UI

Table 61: PCI Express Interface Parameters (Cont.)

Parameter	Symbol	Comments	Minimum	Typical	Maximum	Unit
RX detection voltage swing	VTX-RCV-DETECT	The amount of voltage change allowed during receiver detection.	–	–	600	mV
TX AC peak common-mode voltage (5 GT/s)	VTX-CM-AC-PP	TX AC common mode voltage (5 GT/s)	–	–	100	mV
TX AC peak common-mode voltage (2.5 GT/s)	VTX-CM-AC-P	TX AC common mode voltage (2.5 GT/s)	–	–	20	mV
Absolute delta of DC common-model voltage during L0 and electrical idle	VTX-CM-DC-ACTIVE-IDLE-DELTA	Absolute delta of DC common-model voltage during L0 and electrical idle.	0	–	100	mV
Absolute delta of DC common-model voltage between D+ and D–	VTX-CM-DC-LINE-DELTA	DC offset between D+ and D–	0	–	25	mV
Electrical idle differential peak output p voltage	VTX-IDLE-DIFF-AC-	Peak-to-peak voltage	0	–	20	mV
TX short circuit current	ITX-SHORT	Current limit when TX output is shorted to ground.	–	–	90	mA
DC differential TX termination	ZTX-DIFF-DC	Low impedance defined during signaling (parameter is captured for 5.0 GHz by RLTX-DIFF)	80	–	120	Ω
Differential return loss	RLTX-DIFF	Differential return loss	10 (min) for 0.05: 1.25 GHz 8 (min) for 1.25: 2.5 GHz	–	–	dB
Common-mode return loss	RLTX-CM	Common-mode return loss	6	–	–	dB
TX eye width	TTX-EYE	Minimum TX eye width	0.75	–	–	UI

JTAG Timing

Table 62: JTAG Timing Characteristics

<i>Signal Name</i>	<i>Period</i>	<i>Output Maximum</i>	<i>Output Minimum</i>	<i>Setup</i>	<i>Hold</i>
TCK	125 ns	–	–	–	–
TDI	–	–	–	20 ns	0 ns
TMS	–	–	–	20 ns	0 ns
TDO	–	100 ns	0 ns	–	–
JTAG_TRST	250 ns	–	–	–	–

Section 21: Power-Up Sequence and Timing

Sequencing of Reset and Regulator Control Signals

The BCM4339 has two signals that allow the host to control power consumption by enabling or disabling the Bluetooth, WLAN, and internal regulator blocks. These signals are described below. Additionally, diagrams are provided to indicate proper sequencing of the signals for various operational states (see [Figure 53](#), [Figure 54 on page 173](#), and [Figure 55](#) and [Figure 56 on page 174](#)). The timing values indicated are minimum required values; longer delays are also acceptable.

Description of Control Signals

- **WL_REG_ON**: Used by the PMU to power up the WLAN section. It is also OR-gated with the BT_REG_ON input to control the internal BCM4339 regulators. When this pin is high, the regulators are enabled and the WLAN section is out of reset. When this pin is low the WLAN section is in reset. If both the BT_REG_ON and WL_REG_ON pins are low, the regulators are disabled.
- **BT_REG_ON**: Used by the PMU (OR-gated with WL_REG_ON) to power up the internal BCM4339 regulators. If both the BT_REG_ON and WL_REG_ON pins are low, the regulators are disabled. When this pin is low and WL_REG_ON is high, the BT section is in reset.



Note:

- For both the WL_REG_ON and BT_REG_ON pins, there should be at least a 10 ms time delay between consecutive toggles (where both signals have been driven low). This is to allow time for the CBUCK regulator to discharge. If this delay is not followed, then there may be a VDDIO in-rush current on the order of 36 mA during the next PMU cold start.
- The reset requirements for the Bluetooth core are also applicable for the FM core. In other words, if FM is to be used, then the Bluetooth core must be enabled.
- The BCM4339 has an internal power-on reset (POR) circuit. The device will be held in reset for a maximum of 110 ms after VDDC and VDDIO have both passed the POR threshold. Wait at least 150 ms after VDDC and VDDIO are available before initiating SDIO accesses.
- VBAT should not rise 10%–90% faster than 40 microseconds. VBAT should be up before or at the same time as VDDIO. VDDIO should NOT be present first or be held high before VBAT is high.

Control Signal Timing Diagrams

Figure 53: WLAN = ON, Bluetooth = ON

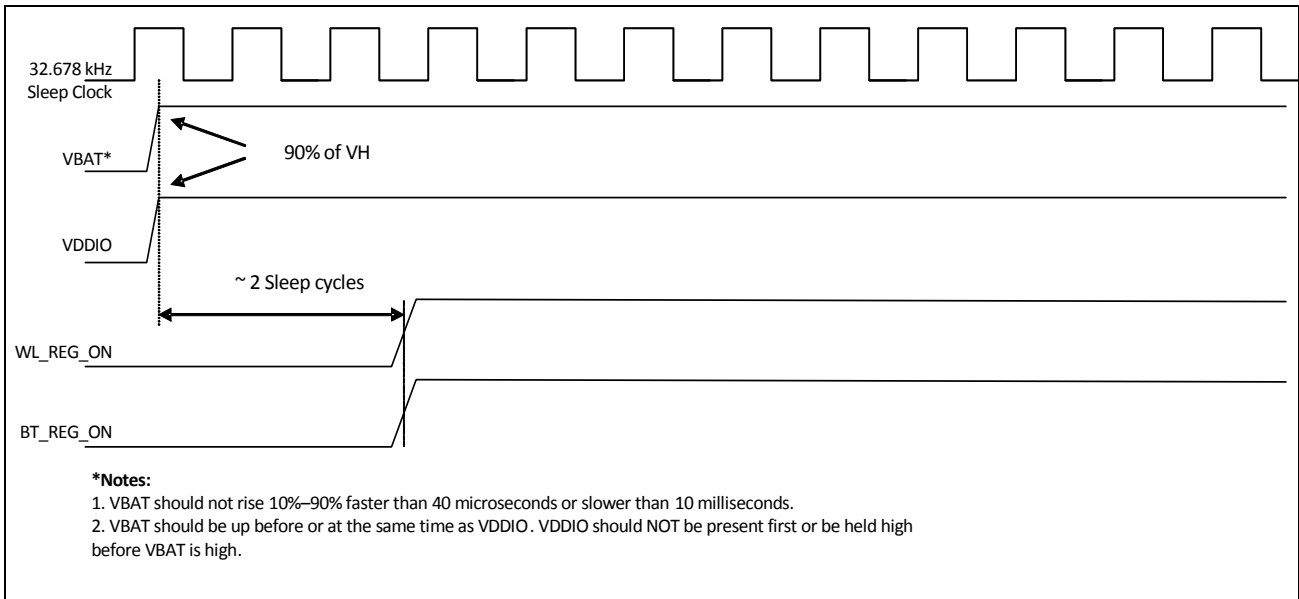

Figure 54: WLAN = OFF, Bluetooth = OFF

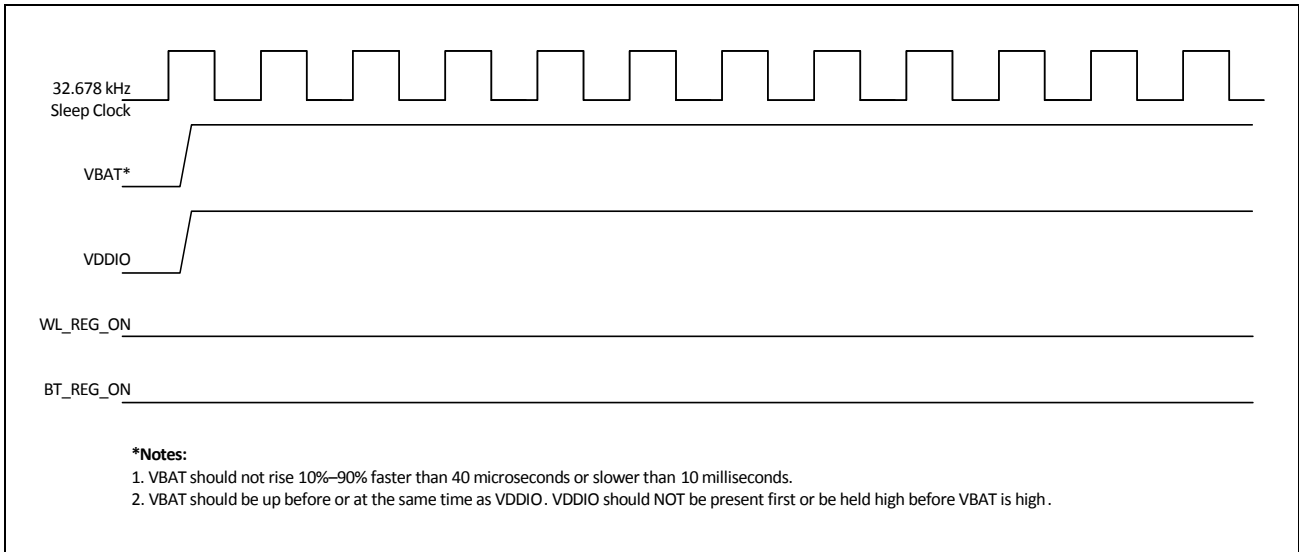

Figure 55: WLAN = ON, Bluetooth = OFF

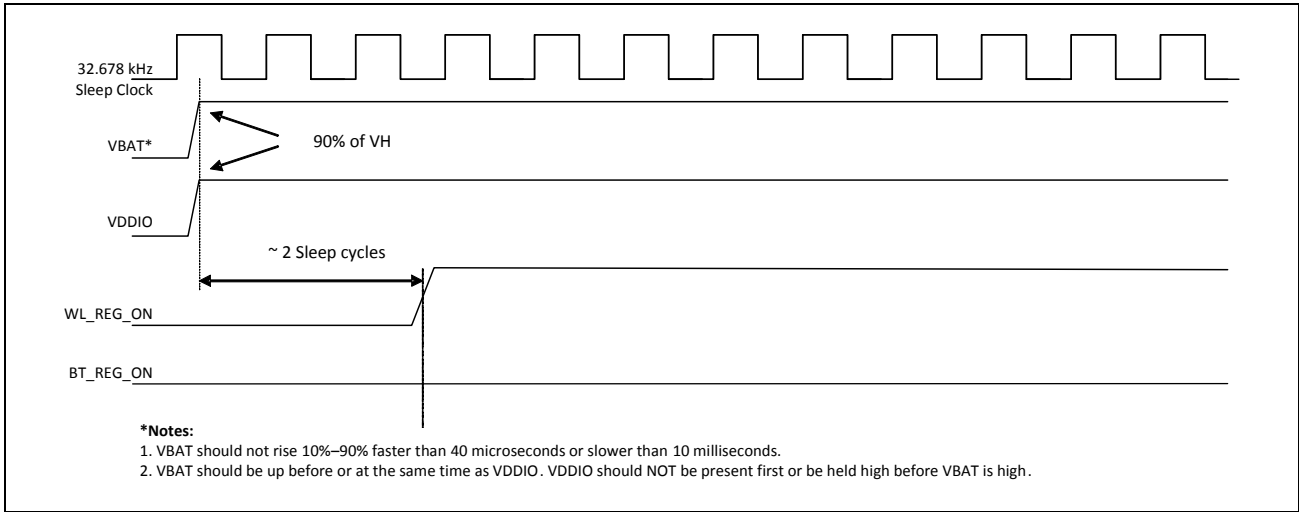
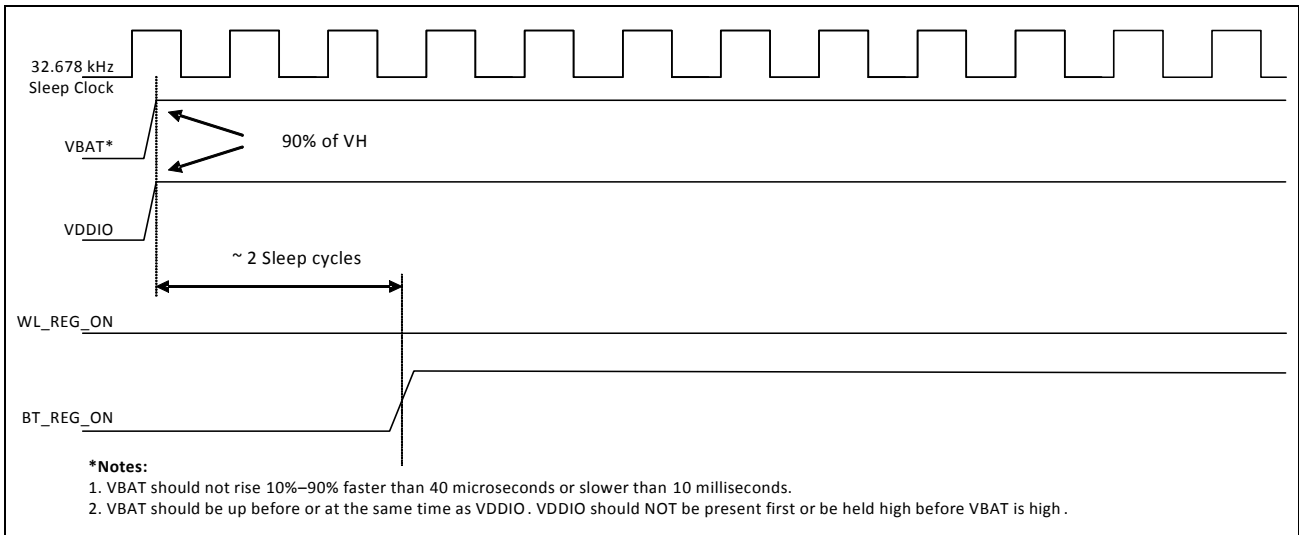

Figure 56: WLAN = OFF, Bluetooth = ON



Section 22: Package Information

Package Thermal Characteristics

Table 63: Package Thermal Characteristics^a

Characteristic	FCFBGA	WLBGA	WLCSP
θ_{JA} (°C/W) (value in still air)	48.03	32.9	33.45
θ_{JB} (°C/W)	17.01	2.56	3.45
θ_{JC} (°C/W)	24.52	0.98	1.00
Ψ_{JT} (°C/W)	10.78	3.30	3.45
Ψ_{JB} (°C/W)	18.02	9.85	10.64
Maximum Junction Temperature T_j (°C)	125	125	125
Maximum Power Dissipation (W)	1.41	1.119	1.119

a. No heat sink, $T_A = 70^\circ\text{C}$. This is an estimate, based on a 4-layer PCB that conforms to EIA/JESD51-7 (101.6 mm × 101.6 mm × 1.6 mm) and P = specified power maximum continuous power dissipation.

Junction Temperature Estimation and Ψ_{JT} Versus θ_{JC}

Package thermal characterization parameter Ψ_{JT} yields a better estimation of actual junction temperature (T_J) versus using the junction-to-case thermal resistance parameter θ_{JC} . The reason for this is that θ_{JC} assumes that all the power is dissipated through the top surface of the package case. In actual applications, some of the power is dissipated through the bottom and sides of the package. Ψ_{JT} takes into account power dissipated through the top, bottom, and sides of the package. The equation for calculating the device junction temperature is:

$$T_J = T_T + P \times \Psi_{JT}$$

Where:

- T_J = Junction temperature at steady-state condition (°C)
- T_T = Package case top center temperature at steady-state condition (°C)
- P = Device power dissipation (Watts)
- Ψ_{JT} = Package thermal characteristics; no airflow (°C/W)

Environmental Characteristics

For environmental characteristics data, see [Table 31: "Environmental Ratings," on page 123.](#)

Section 23: Mechanical Information

Figure 57: 160-Ball FCFBGA Package Mechanical Information

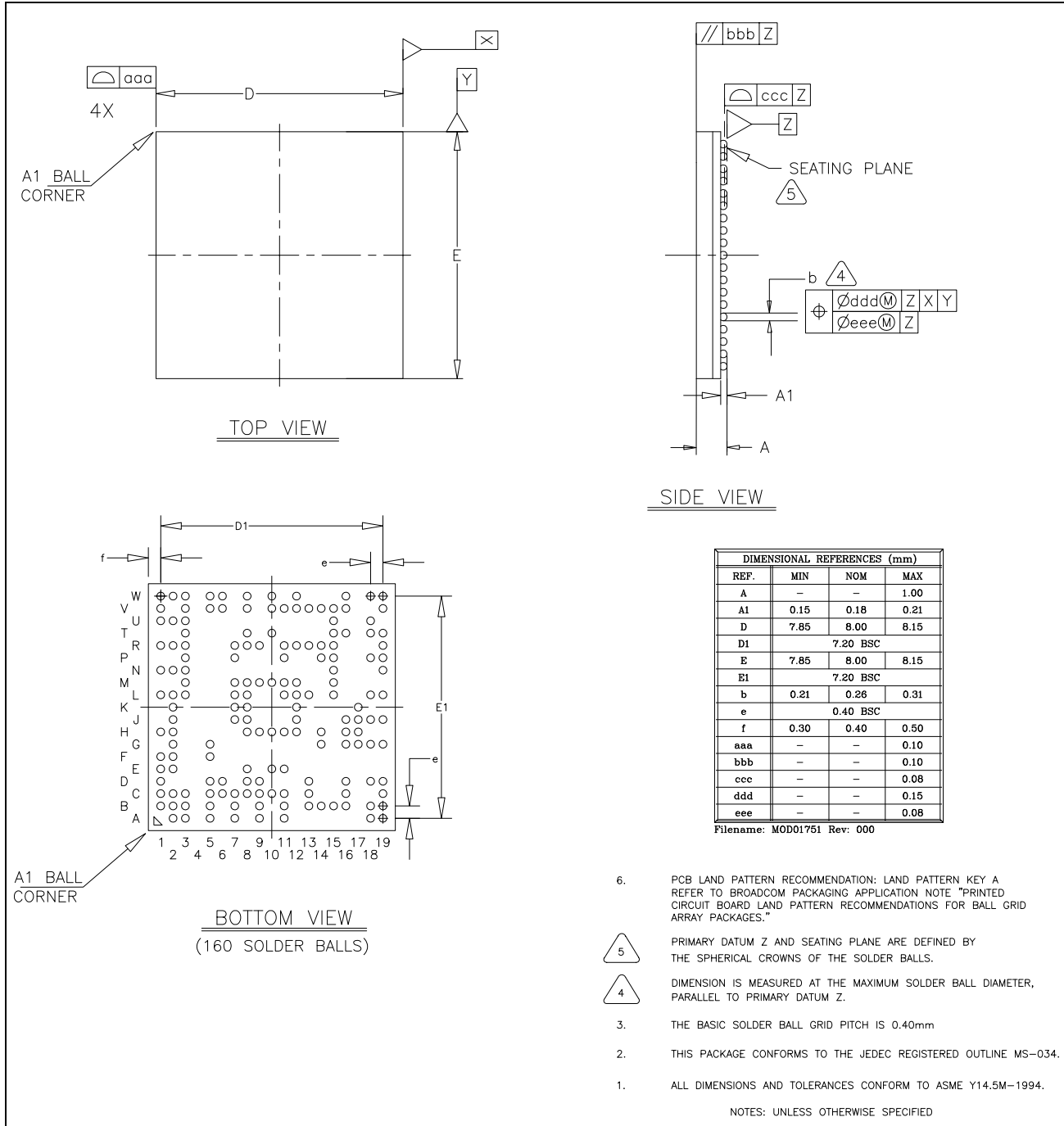

Figure 58: 145-Ball WLBGA Package Mechanical Information

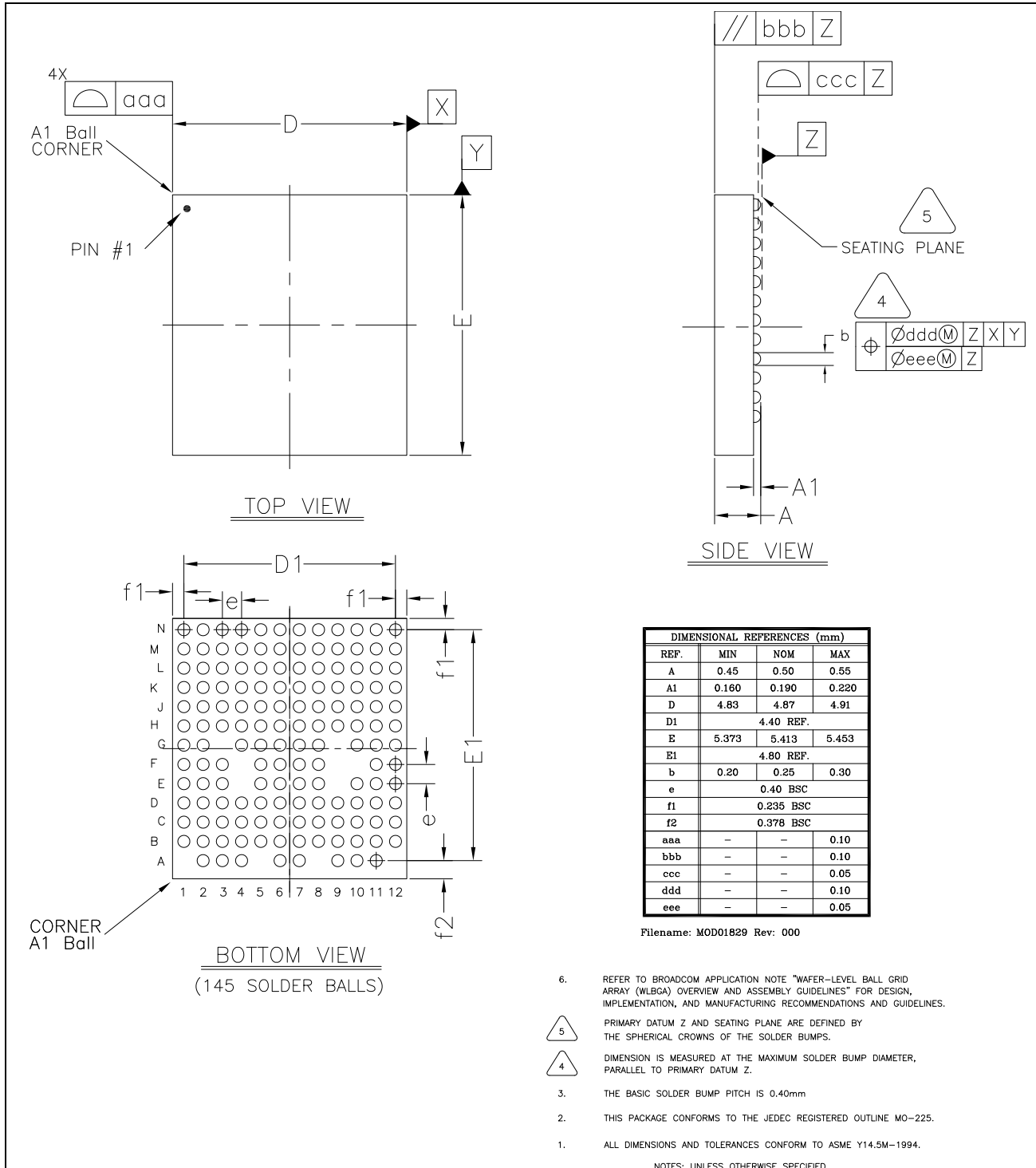
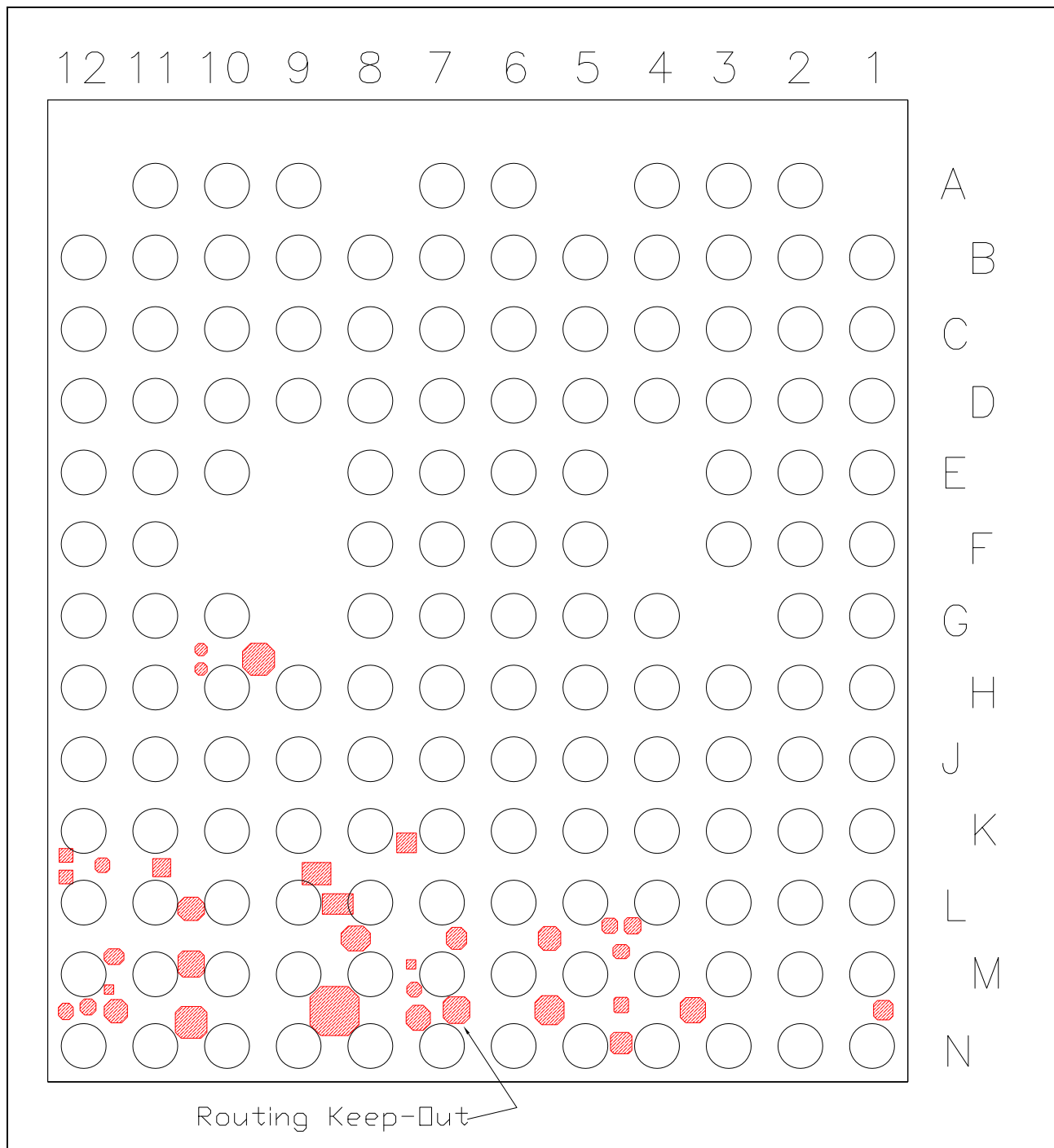

Figure 59: WLBGA Keep-out Areas for PCB Layout—Bottom View with Balls Facing Up



Note: No top-layer metal is allowed in keep-out areas.

Figure 60: 286-Bump WLCSP Package Mechanical Information

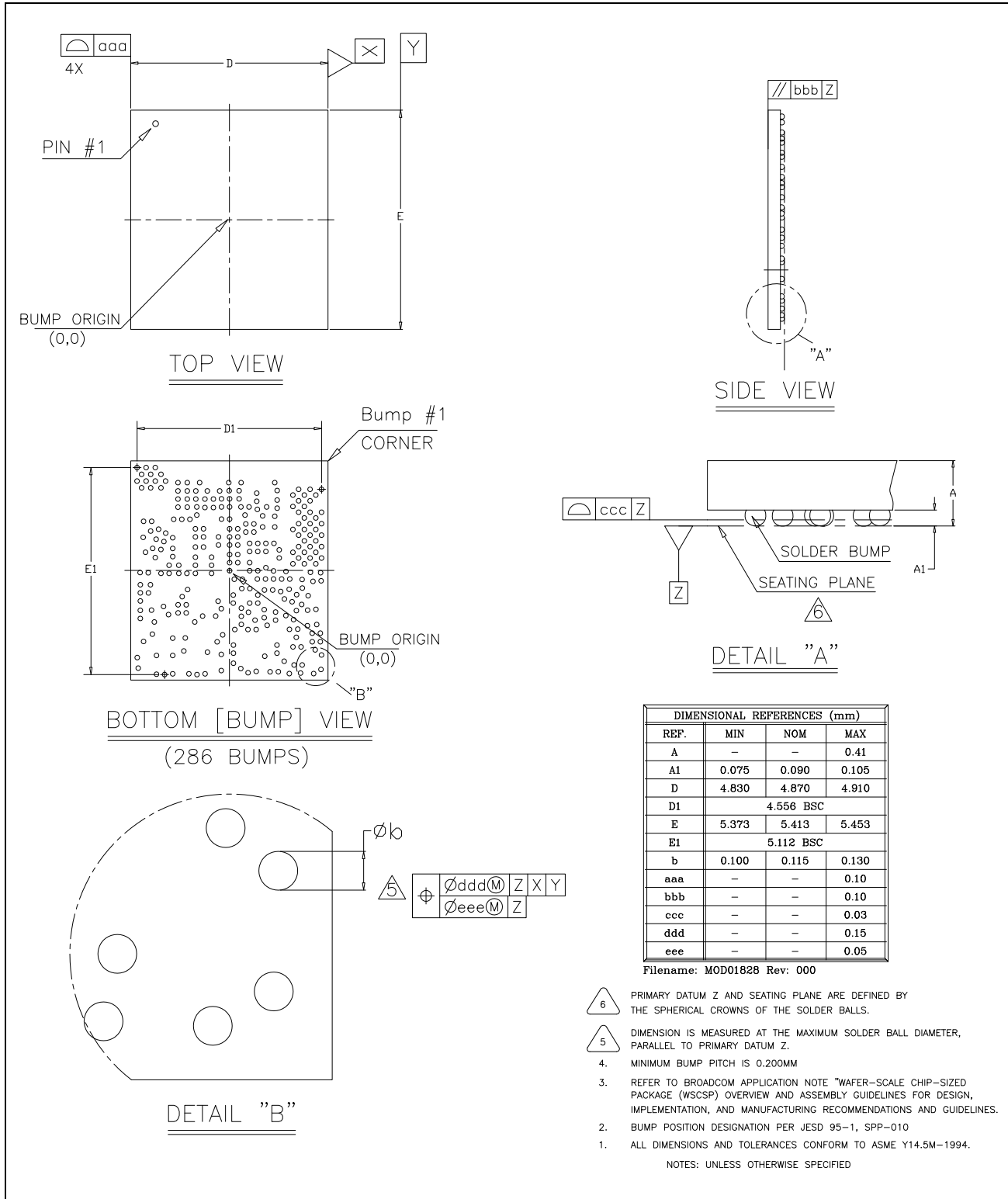
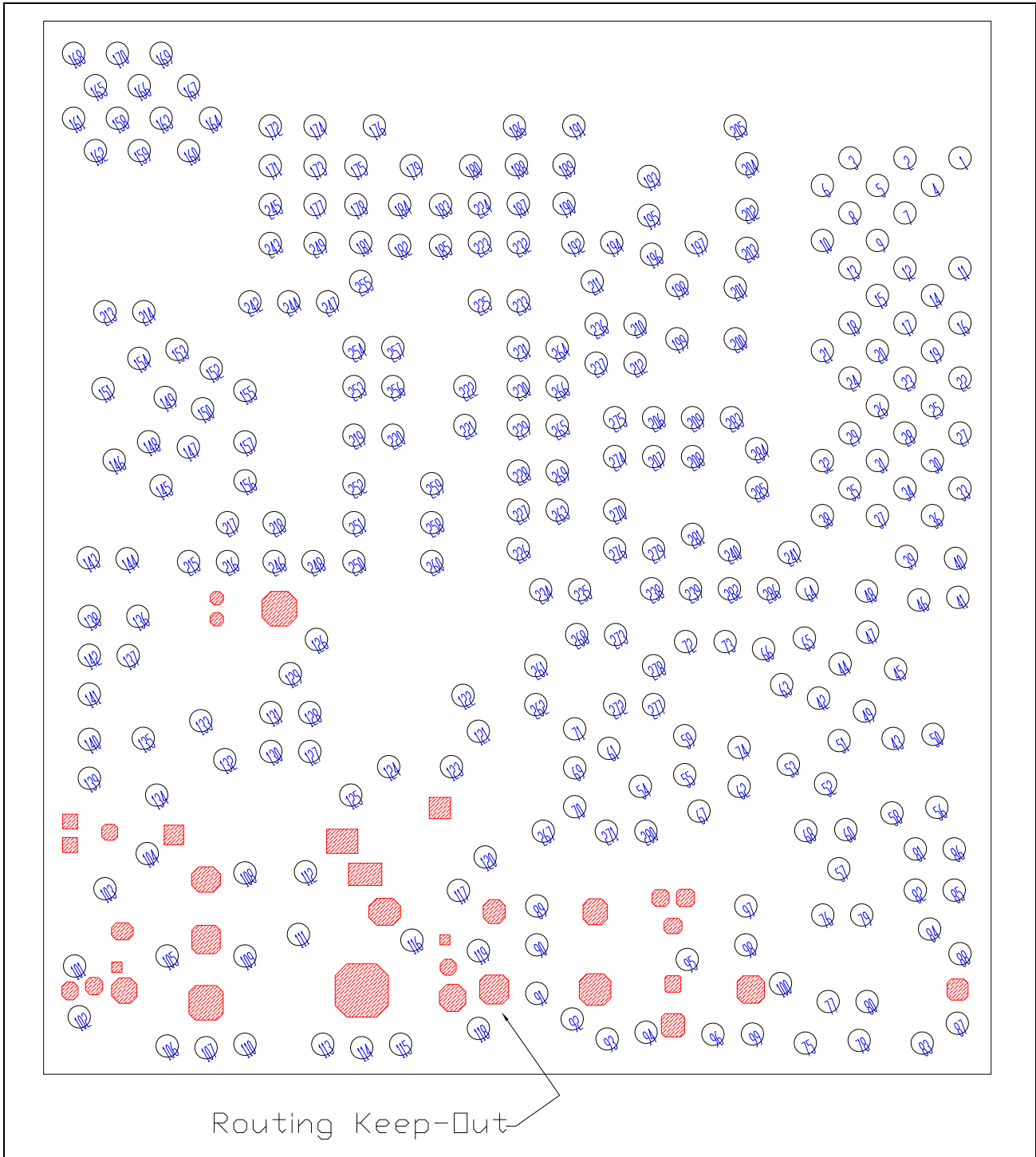

Figure 61: WLCSP Keep-out Areas for PCB Layout—Bottom View with Bumps Facing Up



Note: No top-layer metal is allowed in keep-out areas.

Section 24: Ordering Information

<i>Part Number</i>	<i>Package</i>	<i>Description</i>	<i>Operating Ambient Temperature</i>
BCM4339NKFFBG	160-ball FCFBGA (8 mm × 8 mm, 0.4 mm pitch)	Dual-band 2.4 GHz and 5 GHz WLAN + BT 4.1	–30°C to +85°C
BCM4339XKWBG	286-bump WLCSP (4.87 mm × 5.413 mm, 0.2 mm pitch)	Dual-band 2.4 GHz and 5 GHz WLAN + BT 4.1 for FMRX	–30°C to +85°C
BCM4339XKUBG	145-ball WLBGA (4.87 mm × 5.413 mm, 0.4 mm pitch)	Dual-band 2.4 GHz and 5 GHz WLAN + BT 4.1 + FMRX	–30°C to +85°C

Broadcom® Corporation reserves the right to make changes without further notice to any products or data herein to improve reliability, function, or design.

Information furnished by Broadcom Corporation is believed to be accurate and reliable. However, Broadcom Corporation does not assume any liability arising out of the application or use of this information, nor the application or use of any product or circuit described herein, neither does it convey any license under its patent rights nor the rights of others.

Broadcom Corporation

5300 California Avenue
Irvine, CA 92617

© 2014 by BROADCOM CORPORATION. All rights reserved.

4339-DS106-R

November 17, 2014



Phone: 949-926-5000

Fax: 949-926-5203

E-mail: info@broadcom.com

Web: www.broadcom.com