

4

3

2

1

DO NOT SCALE DRAWING

THE INFORMATION CONTAINED HEREIN IS THE EXCLUSIVE PROPERTY OF VIRGINIA PANEL CORPORATION AND IS SUBMITTED FOR USE BY THE CUSTOMER ONLY. THE DATA SHALL NOT BE DUPLICATED, USED, OR DISCLOSED IN WHOLE OR IN PART FOR ANY PURPOSE OTHER THAN TO MAINTAIN THE EQUIPMENT PROVIDED. CONSULT WITH VIRGINIA PANEL CORPORATION ENGINEERING IF MORE DETAIL IS REQUIRED.

REVISIONS			
REV	DESCRIPTION	DATE	ENGR
E	ECN #7365	4/5/17	R HERRON

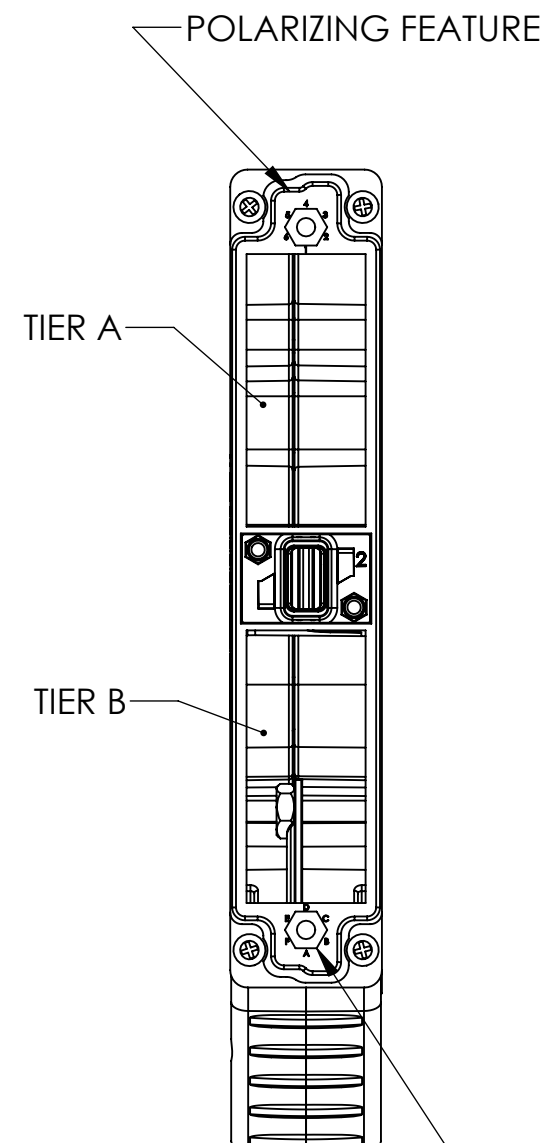
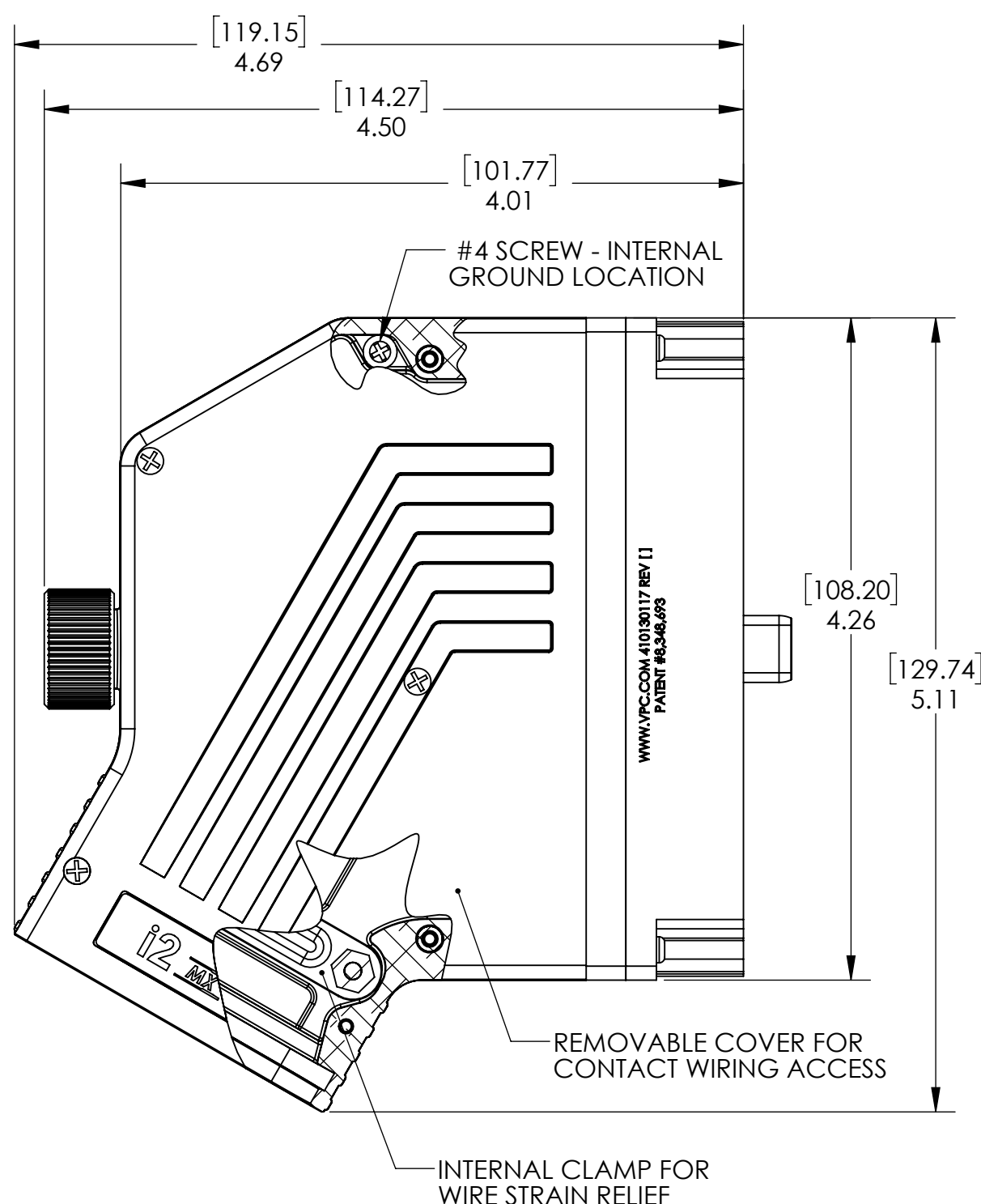
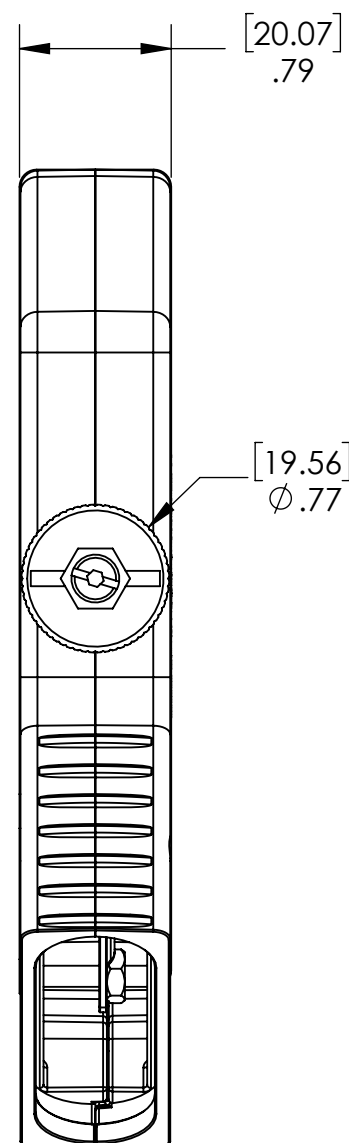
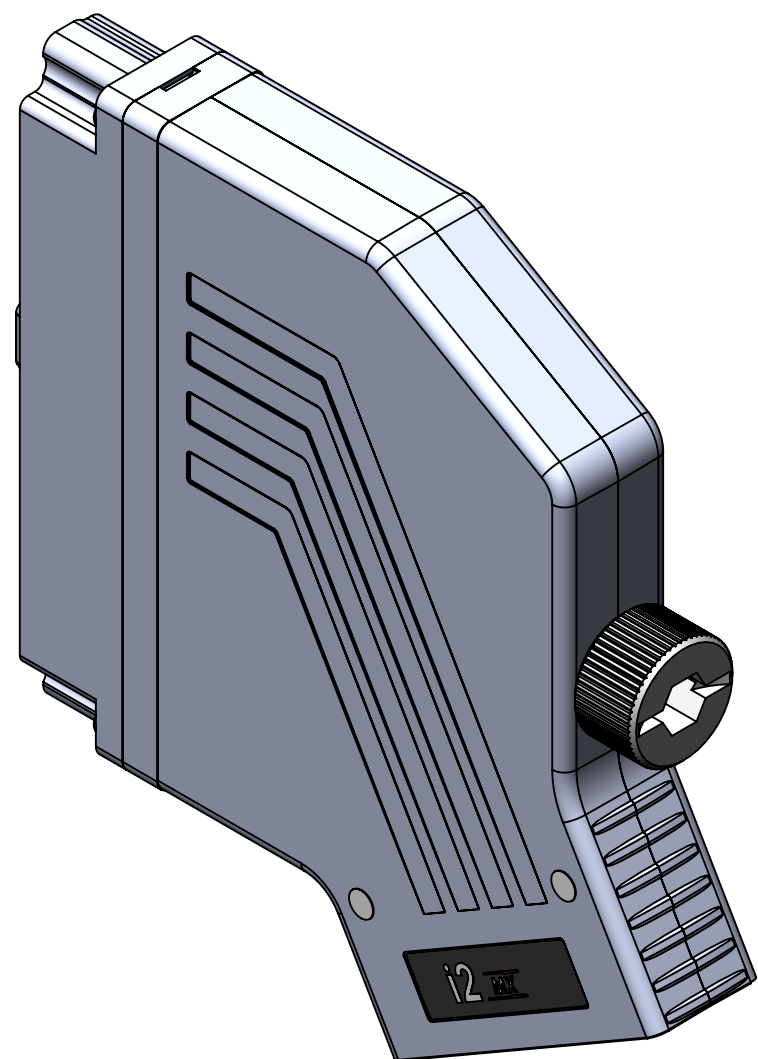

CAVITY FOR KEYING KIT, TYP. 2 PLCS. ACCESSORY P/N 310113461 (2 KEYS PER KIT) NOT INCLUDED WITH ITA

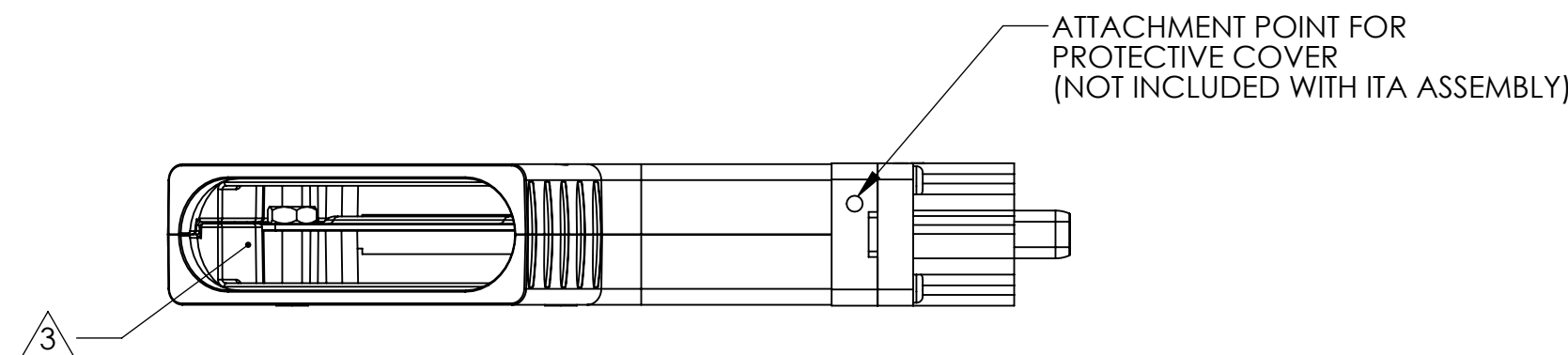

3 MAX CABLE BUNDLE EFFECTIVE DIAMETER = 1.00 IN.

2. MATERIALS:  
 FRAME & DRIVE KNOB: Ni PLATED ZINC  
 BACK SHELL: Ni PLATED ALUMINUM  
 DRIVE SYSTEM: BeCu AND BRONZE, Ni PLATED  
 HARDWARE: STAINLESS STEEL

1. FOR APPLICATION USE & CARE INFORMATION CONSULT VPC USERS GUIDE @WWW.VPC.COM

NOTES:

RELATIVE CONNECTOR POSITIONS AND WIRE ROUTING ARE GENERIC AND MAY VARY WITH P/N/OUT			
DIMENSIONS ARE SHOWN AS:	SIZE	CAGE CODE	DWG. NO.
[MILLIMETERS]	C	18117	410130117
INCHES			
SCALE: 1:1	410130117	8/28/14	SHEET 1 OF 1

**CUSTOMER DRAWING**  
**VIRGINIA PANEL CORPORATION**  
 WWW.VPC.COM  
**i2 MX ITA ASSEMBLY**  
**MODULAR NON-EMI**

4

3

2

1