

## Plug-in Signal Conditioners K-UNIT

### SIGNAL TRANSMITTER

(two isolated outputs)

#### Functions & Features

- Converting a DC input into two standard process signals
- Fast response type available
- High-density mounting

#### Typical Applications

- Isolation between control room and field instrumentation

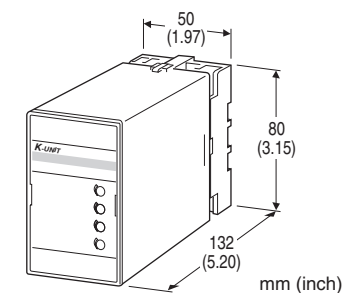

### MODEL: KWVS-[1][2][3]-[4][5]

#### ORDERING INFORMATION

- Code number: KWVS-[1][2][3]-[4][5]

Specify a code from below for each of [1] through [5].

- (e.g. KWVS-6AA-B/K/Q)
- Special input and output ranges (For codes Z & 0)
- Specify the specification for option code /Q (e.g. /C01/S01)

Note: When the user requires a current and a voltage output, specify the current to be the Output 1 which allows a greater load.

#### [1] INPUT

##### Current

- A: 4 - 20 mA DC (Input resistance 250 Ω)
- A1: 4 - 20 mA DC (Input resistance 50 Ω)
- B: 2 - 10 mA DC (Input resistance 500 Ω)
- C: 1 - 5 mA DC (Input resistance 1000 Ω)
- D: 0 - 20 mA DC (Input resistance 50 Ω)
- E: 0 - 16 mA DC (Input resistance 62.5 Ω)
- F: 0 - 10 mA DC (Input resistance 100 Ω)
- G: 0 - 1 mA DC (Input resistance 1000 Ω)
- H: 10 - 50 mA DC (Input resistance 100 Ω)
- J: 0 - 10 μA DC (Input resistance 1000 Ω)
- K: 0 - 100 μA DC (Input resistance 1000 Ω)
- GW: -1 - +1 mA DC (Input resistance 1000 Ω)
- FW: -10 - +10 mA DC (Input resistance 100 Ω)

Z: Specify current (See INPUT SPECIFICATIONS)

##### Voltage

- 1: 0 - 10 mV DC (Input resistance 10 kΩ min.)
- 15: 0 - 50 mV DC (Input resistance 10 kΩ min.)
- 16: 0 - 60 mV DC (Input resistance 10 kΩ min.)
- 2: 0 - 100 mV DC (Input resistance 100 kΩ min.)
- 3: 0 - 1 V DC (Input resistance 1 MΩ min.)
- 4: 0 - 10 V DC (Input resistance 1 MΩ min.)
- 5: 0 - 5 V DC (Input resistance 1 MΩ min.)
- 6: 1 - 5 V DC (Input resistance 1 MΩ min.)
- 4W: -10 - +10 V DC (Input resistance 1 MΩ min.)
- 5W: -5 - +5 V DC (Input resistance 1 MΩ min.)
- 0: Specify voltage (See INPUT SPECIFICATIONS)

#### [2] OUTPUT 1

##### Current

- A: 4 - 20 mA DC (Load resistance 600 Ω max.)
- B: 2 - 10 mA DC (Load resistance 1200 Ω max.)
- C: 1 - 5 mA DC (Load resistance 2400 Ω max.)
- D: 0 - 20 mA DC (Load resistance 600 Ω max.)
- E: 0 - 16 mA DC (Load resistance 750 Ω max.)
- F: 0 - 10 mA DC (Load resistance 1200 Ω max.)
- G: 0 - 1 mA DC (Load resistance 12 kΩ max.)
- Z: Specify current (See OUTPUT SPECIFICATIONS)

##### Voltage

- 1: 0 - 10 mV DC (Load resistance 10 kΩ min.)
- 2: 0 - 100 mV DC (Load resistance 100 kΩ min.)
- 3: 0 - 1 V DC (Load resistance 1000 Ω min.)
- 4: 0 - 10 V DC (Load resistance 10 kΩ min.)
- 5: 0 - 5 V DC (Load resistance 5000 Ω min.)
- 6: 1 - 5 V DC (Load resistance 5000 Ω min.)
- 4W: -10 - +10 V DC (Load resistance 10 kΩ min.)
- 5W: -5 - +5 V DC (Load resistance 5000 Ω min.)
- 0: Specify voltage (See OUTPUT SPECIFICATIONS)

#### [3] OUTPUT 2

##### Current

- A: 4 - 20 mA DC (Load resistance 350 Ω max.)
- B: 2 - 10 mA DC (Load resistance 700 Ω max.)
- C: 1 - 5 mA DC (Load resistance 1400 Ω max.)
- D: 0 - 20 mA DC (Load resistance 350 Ω max.)
- E: 0 - 16 mA DC (Load resistance 430 Ω max.)
- F: 0 - 10 mA DC (Load resistance 700 Ω max.)
- G: 0 - 1 mA DC (Load resistance 7000 Ω max.)
- Z: Specify current (See OUTPUT SPECIFICATIONS)

##### Voltage

Same range availability as Output 1

#### [4] POWER INPUT

##### AC Power

- B: 100 V AC

C: 110 V AC  
 D: 115 V AC  
 F: 120 V AC  
 G: 200 V AC  
 H: 220 V AC  
 J: 240 V AC  
**DC Power**  
 S: 12 V DC  
 R: 24 V DC

## [5] OPTIONS (multiple selections)

### Response Time (0 - 90 %)

blank: Standard ( $\leq 0.5$  sec.)

/K: Fast Response (Approx. 25 msec.)

### Other Options

blank: none

/Q: Option other than the above (specify the specification)

## SPECIFICATIONS OF OPTION: Q (multiple selections)

### COATING (For the detail, refer to M-System's web site.)

/C01: Silicone coating

/C02: Polyurethane coating

/C03: Rubber coating

### TERMINAL SCREW MATERIAL

/S01: Stainless steel

## GENERAL SPECIFICATIONS

**Construction:** Plug-in

**Connection:** M3.5 screw terminals

**Screw terminal:** Chromated steel (standard) or stainless steel

**Housing material:** Flame-resistant resin (black)

**Isolation:** Input to output 1 to output 2 to power

**Overrange output:** Approx. -10 to +120 % at 1 - 5 V

**Zero adjustment:** -5 to +5 % (front)

**Span adjustment:** 95 to 105 % (front)

Adjustable individually for each output 1 and output 2.

## INPUT SPECIFICATIONS

### ■ DC Current:

Shunt resistor attached to the input terminals (0.5 W)

Specify input resistance value for code Z.

### ■ DC Voltage: -300 - +300 V DC

**Minimum span:** 3 mV

**Offset:** Max. 1.5 times span

### Input resistance

Span 3 - 10 mV :  $\geq 10$  k $\Omega$

Span 10 - 100 mV :  $\geq 10$  k $\Omega$

Span 0.1 - 1 V :  $\geq 100$  k $\Omega$

Span  $\geq 1$  V :  $\geq 1$  M $\Omega$

## OUTPUT SPECIFICATIONS

### ■ DC Current: 0 - 20 mA DC

**Minimum span:** 1 mA

**Offset:** Max. 1.5 times span

**Load resistance:** Output drive 12 V max. for Output 1;  
7 V max. for Output 2

### ■ DC Voltage: -10 - +12 V DC

**Minimum span:** 5 mV

**Offset:** Max. 1.5 times span

**Load resistance:** Output drive 1 mA max. at  $\geq 0.5$  V

## INSTALLATION

### Power input

•AC: Operational voltage range: rating  $\pm 10$  %, 50/60  $\pm 2$  Hz, approx. 3 VA

•DC: Operational voltage range: rating  $\pm 10$  % ripple 10 %p-p max., approx. 3 W (125 mA at 24 V)

**Operating temperature:** -5 to +55°C (23 to 131°F)

**Operating humidity:** 30 to 90 %RH (non-condensing)

**Mounting:** Surface or DIN rail

**Weight:** 400 g (0.88 lb)

## PERFORMANCE in percentage of span

**Accuracy:**  $\pm 0.1$  %

**Temp. coefficient:**  $\pm 0.02$  %/°C ( $\pm 0.01$  %/°F)

**Line voltage effect:**  $\pm 0.1$  % over voltage range

**Insulation resistance:**  $\geq 100$  M $\Omega$  with 500 V DC

**Dielectric strength:** 2000 V AC @1 minute

(input to output to power to ground)

1000 V AC @ 1 minute (output 1 to output 2)

## EXTERNAL DIMENSIONS unit: mm (inch)

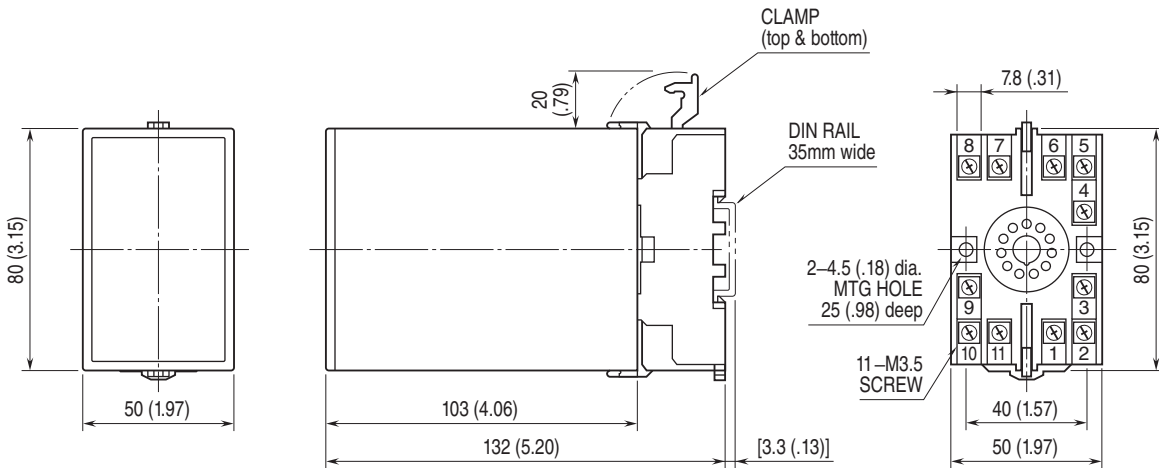

• When mounting, no extra space is needed between units.

## TERMINAL ASSIGNMENTS unit: mm (inch)

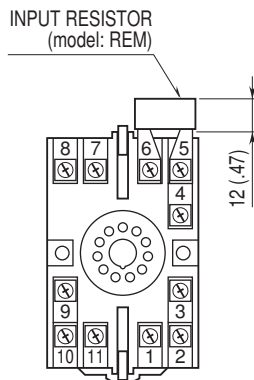

Input shunt resistor attached for current input.

## SCHEMATIC CIRCUITRY & CONNECTION DIAGRAM

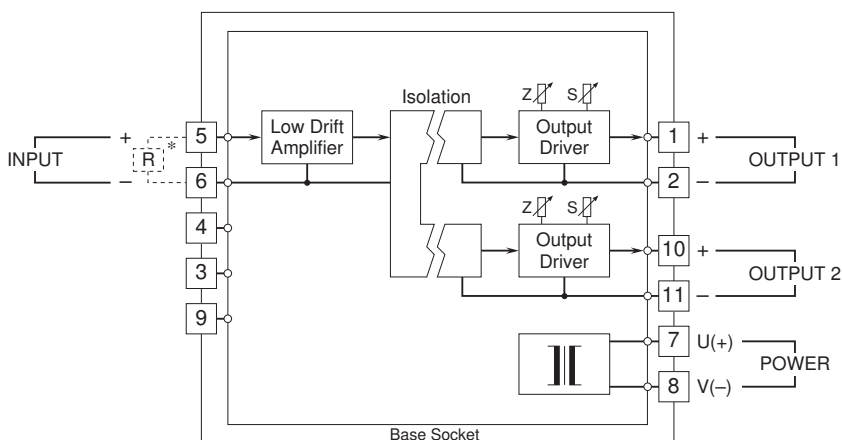

\*Input shunt resistor attached for current input.



Specifications are subject to change without notice.