



O/E/N 74

AUTOMOTIVE POWER RELAY

FEATURES

- High performance
- 6.3mm Flat Terminals
- Current rating up to 40A
- Suitable Couplers available
- Optional Sealing

APPLICATION

- Horn Control
- Starter Motors
- Defogger
- Radiator Fan
- A/C Controls
- Security Systems

TECHNICAL DATA FOR CONTACT SIDE :

Model	:	74	74-SC
Areas of Application	:	RESISTIVE / INDUCTIVE/HEAD LAMP/CAPACITIVE LOADS	
Contact Configuration	:	1A/1C	1A/1C
Contact Material	:	Silver Nickel	Silver Nickel / Silver Tin Oxide*
Contact Rating at 23°C - 12VDC (Res.)	NO :	30	40
	NC :	20	30
Electrical Life Operations Min.	:	2 x 10 ⁵	2 x 10 ⁵
Mechanical Life Operations Min.	:	1 x 10 ⁶	1 x 10 ⁶
Contact Voltage Drop at 10 A (Min)	:	50mV	50mV
Maximum Switching Current @ 12.8 VDC For 3 Sec.	:	120A	150A

*Under introduction

GENERAL DATA FOR COIL SIDE

Nominal Coil Power	:	1.6W (Approx)
Operating Power	:	1.8W (Approx)
Operate Time**	:	15 milli Seconds
Release Time**	:	15 milli Seconds

** At nominal voltage without coil suppression (excluding bounce)

OPERATING CONDITIONS

Ambient Temperature	:	-30°C to +85°C
Maximum Temperature	:	155°C
Dielectric Strength	:	500VRMS
Insulation Resistance	:	100 Meg. Ohms Min. At 500 VDC, 25°C RH 50
Vibration Resistance (without change in the switching state > 10μS)	:	10-2000Hz 4.4g
Shock Resistance (without change in the switching state > 10μS)	:	30g, 8mS

CIRCUIT DIAGRAM

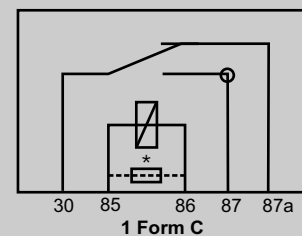
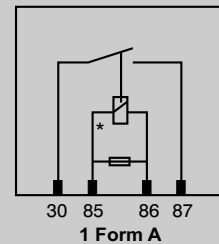

* parallel resistor or diode optional

HOW TO ORDER

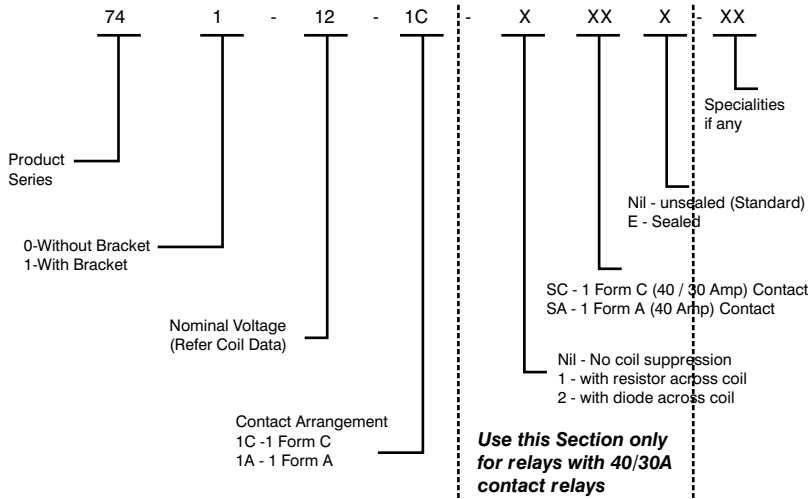

COIL DATA

Nominal Voltage VDC	***Pick-up Voltage VDC (Max)	Drop-out Voltage VDC (Min)	Coil Resistance Ohms ($\pm 10\%$)
12	8	1.2	85
24	17	2.4	305

***Lower pick-up Voltages available on request

DIMENSIONS

Relay without Bracket

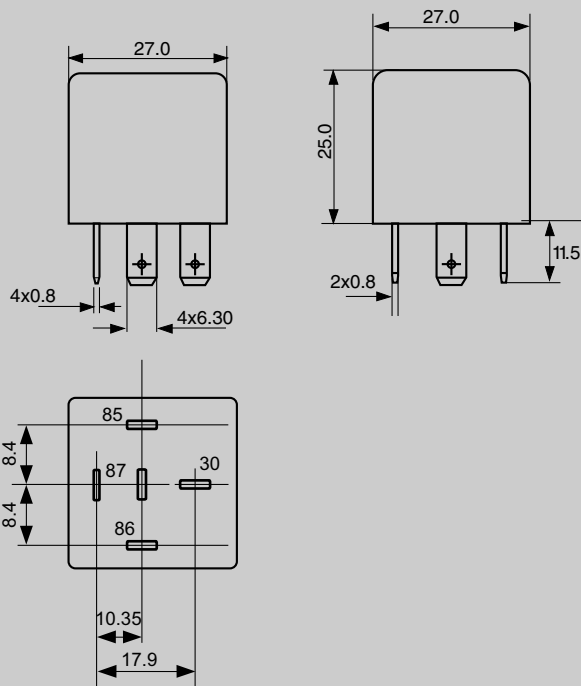

Relay with Bracket

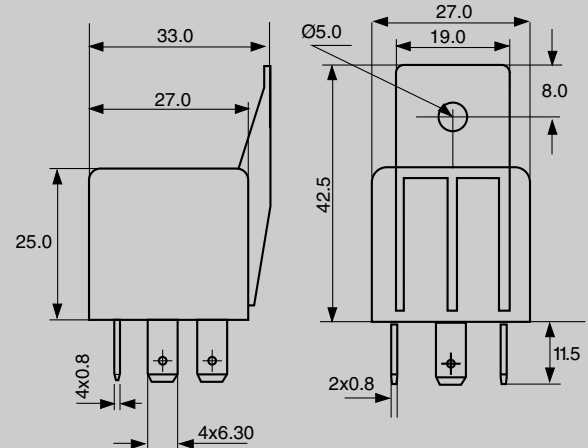

MECHANICAL DATA

COVER RETENTION

Pull : 20KgF

Push : 20KgF

TERMINAL STRENGTH

Pull : 10KgF

Push : 10KgF

AVAILABLE ON REQUEST

- High temperature winding wire
- Special Contact arrangements
- Special coil resistance & pick-up
- Resistor / Diode across coil
- For other custom solutions consult factory

DATA ON VARIOUS TESTS CONDUCTED FOR OPERATING CONDITIONS

TEST	TEST CONDITION	RESULT
Continuous Energisation test at Extreme temperature Conditions	Relay kept at 100°C Coil Voltage : 14 VDC Load given : 25 A @ 12 VDC Duration : 5 Sec. On, 5 Sec. OFF No. of operation : 50000 The above test repeated at - 30°C for 50000 operations	Relays successfully completed 100000 operations at given load
Thermal cycling	Relay subjected to :- -30°C to + 100°C in 2 Hrs. with coil ON +100°C for 2 Hrs. with coil ON +100°C to - 30°C in 2 Hrs. with 1 Hrs. Coil ON & 1 Hrs. Coil OFF -30°C for two Hrs. with Coil ON No. of Cycles : 3	All operating parameters within the specifications after test
Shock Voltage	Relay is subjected to :- Max. Voltage : 100VDC Shock Wave : Exponential Damping vibration Time : 500 micro Sec. Period : 30 Sec. Test Time : 10 Hrs.	After the test, all operating parameters of the relay are within specification.
Dropping Impact	Relays dropped from a height of 1 Meter to a concrete floor	No change in operating parameters of the relay.
Jump Start	24 VDC for 1 minute conducting nominal current at 23°C	Withstood successfully
Corrosion Resistance	5% Sodium Chloride solution applied to relay for 48 Hrs.	No damage to relay parts
Water Resistance test	Horizontal Plane:23rev. / Min. Water Pressure:0.03 Mpa Test time:10 Min	No water ingress inside the relay

*Typical values for relays with 12 VDC coil. For higher severity please consult factory

OPTIONAL SPECIAL CIRCUITRY

