

LED Series Sealed High-Intensity Area Lights



Datasheet

High-Power Lighting for use with Banner Vision Systems

To view or download the latest technical information about this product, including specifications, dimensions, accessories, and wiring, see www.bannerengineering.com.

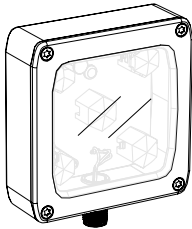

- Rugged, waterproof housing, rated IEC IP68
- Compact area light for Banner Vision systems
- Five extremely bright LEDs for illumination of targets from 0.15 meters to beyond 2 meters
- Smooth exterior for easy cleaning during washdown
- Optically isolated strobe signal
- Available with 316 stainless steel or nickel-plated aluminum housing and a choice of either acrylic or tempered optical glass windows
- Fixed or adjustable intensity, depending on model
- Selectable Active High or Active Low strobe option

Models

Nickel-Plated Aluminum Housing

Fixed-Intensity Models ¹			LED Color
Acrylic Window	Glass Window	Diffuse Window (acrylic)	
LEDRA70AP5-XQ	LEDRA70AG5-XQ	LEDRA70AD5-XQ	Red, 620 nm to 630 nm
LEDWA70AP5-XQ	LEDWA70AG5-XQ	LEDWA70AD5-XQ	White, 5000 K to 8300 K
LEDBA70AP5-XQ	LEDBA70AG5-XQ	LEDBA70AD5-XQ	Blue, 465 nm to 485 nm
LEDGA70AP5-XQ	LEDGA70AG5-XQ	LEDGA70AD5-XQ	Green, 520 nm to 535 nm
LEDIA70AP5-XQ	LEDIA70AG5-XQ	LEDIA70AD5-XQ	Infrared, 850 nm
--	LEDUV365A70AG5-XQ	--	UV, 365 nm
LEDUV395A70AP5-XQ	LEDUV395A70AG5-XQ	LEDUV395A70D5-XQ	UV, 395 nm

316 Stainless Steel Housing

Fixed-Intensity Models ²			LED Color
Acrylic Window	Glass Window	Diffuse Window (acrylic)	
LEDRA70SSP5-XQ	LEDRA70SSG5-XQ	LEDRA70SSD5-XQ	Red, 620 nm to 630 nm
LEDWA70SSP5-XQ	LEDWA70SSG5-XQ	LEDWA70SSD5-XQ	White, 5000 K to 8300 K
LEDBA70SSP5-XQ	LEDBA70SSG5-XQ	LEDBA70SSD5-XQ	Blue, 465 nm to 485 nm
LEDGA70SSP5-XQ	LEDGA70SSG5-XQ	LEDGA70SSD5-XQ	Green, 520 nm to 535 nm
LEDIA70SSP5-XQ	LEDIA70SSG5-XQ	LEDIA70SSD5-XQ	Infrared, 850 nm
--	LEDUV365A70SSG5-XQ	--	UV, 365 nm
LEDUV395A70SSP5-XQ	LEDUV395A70SSG5-XQ	LEDUV395A70SSD5-XQ	UV, 395 nm

The following caution applies to UV, 365 nm models:

¹ For models with adjustable intensity, replace "XQ" with "PQ" in the model number (for example, LEDRA70AP5-PQ).
² For models with adjustable intensity, replace "XQ" with "PQ" in the model number (for example, LEDRA70SSP5-PQ).



**CAUTION:****Risk Group 1: UV Emitted from this product.**

Minimize exposure to eyes or skin. Use appropriate shielding and eye protection. Risk Group 1 (RG 1) products are safe for most use applications, except for very prolonged exposures where direct ocular exposures may be expected.

- IEC 62471

The following caution applies to UV, 395 nm models:

**CAUTION:****Risk Group 2: UV Emitted from this product.**

Eye or skin irritation may result from exposure. Use appropriate shielding and eye protection. Risk Group 2 (RG 2) products generally do not pose a realistic optical hazard if aversion responses limit the exposure duration or where lengthy exposures are unrealistic.

- IEC 62471

Wiring

Wire Purpose	Cable Wire Color ³	Continuous On Mode	Strobed Mode	PresencePlus Pro Controller Terminal Block
Power Wires	Brown (1)	+24 V dc	+24 V dc	Pin 01 ⁴
	Blue (3)	common	common	Pin 02
Strobe Polarity Control	Gray (5)	open	Active Low: open	Open — Active Low
			Active High: connect to common (Blue wire)	Pin 02 — Active High
Strobe Voltage Wires	White (2)	open	0 V dc = ON (Active Low) +5 V dc to 24 V dc = OFF (Active Low)	Pin 04
	Black (4)	open	0 V dc = OFF (Active High) +5 V dc to 24 V dc = ON (Active High)	
			Strobe common	Pin 02

Figure 1. Pinouts for Mating Cordsets

Light Adjustment (Adjustable Intensity Models Only)

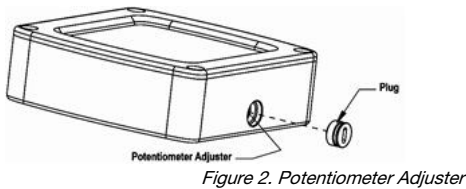

1. Remove the plug as shown in the figure, using a small flat-blade screwdriver.
2. Adjust the light's intensity by turning the 270° Intensity potentiometer with the screwdriver. Apply power to the light and turn the potentiometer all the way clockwise for maximum intensity.
3. If the object to be sensed is too bright at maximum intensity, turn the potentiometer down a little at a time, testing with the object, until the correct brightness is achieved.
4. When adjustment is complete, reinsert the plug.

³ For Banner-supplied wire.

⁴ When connecting the light to a PresencePLUS Pro controller terminal block, the controller supply must be 24 V dc \pm 10%.

Specifications

Supply Voltage and Current

Operating Voltage: 24 V dc \pm 10%
 Strobe Voltage: 5 V dc to 24 V dc at 15 mA max.
 Current Draw at Full Intensity: 500 mA max.
 Built-in constant current regulator for LEDs Adjustable intensity control varies intensity for "P" models
 Use only with a suitable Class 2 power supply (UL) or SELV power supply (CE)

Light Source

Five high-intensity LEDs; see models table for wavelengths

Illumination

610 mm (24 in) diameter usable light pattern at 1 m

Strobe

Optically isolated

Connections

Integral 5-pin M12/Euro-style quick disconnect, accessory cordset required

Construction

Nickel-plated aluminum or stainless steel housing, depending on model; acrylic or glass window, depending on model

Useful Life

When operated within specifications, output will decrease less than 30% after 50,000 hours for visible and IR models; 20,000 hours for UV models

Operating Conditions

0 °C to +50 °C (+32 °F to +122 °F)
 95% maximum relative humidity (non-condensing)

Environmental Rating

Nickel-plated models: IEC IP68
 Stainless steel models: NEMA 4X; IEC IP68

Certifications



Light Characteristics: Clear and Diffuse Window

Values shown are typical @ 25°C.

	Lumens				mWatts		
	Cool White	Green	Red	Blue	IR	UV395	UV365 ⁵
LEDxA70	575	450	225	165	1170	630	440

Optical Data

Area Light Clear Window Isolux Pattern

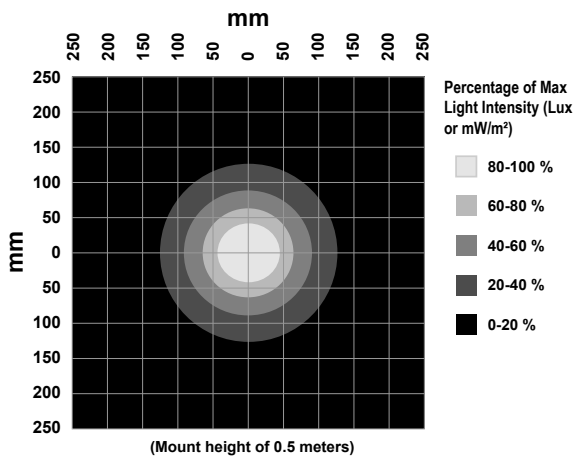

Area Light Diffuse Window Isolux Pattern

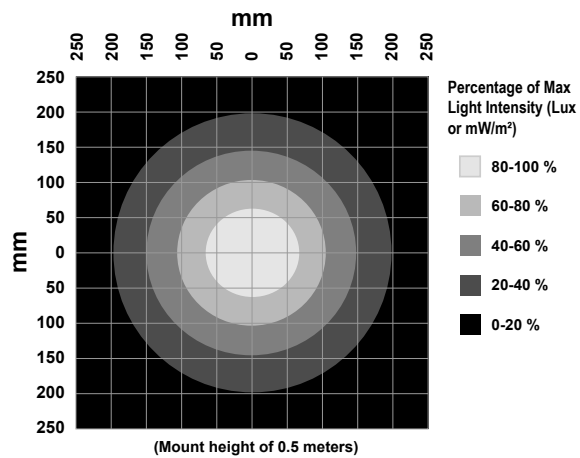

Lux and irradiance values shown are typical at 25 °C and with clear windows; light intensity lowered by 40% on diffuse window models.

Distance (m)	Max Center Beam Lux (lux)				Max Center Beam Irradiance (mW/m ²)			Beam Width (m)	
	Cool White	Green	Red	Blue	IR	UV395	UV365 ⁶	Vertical (Spread 29.1°)	Horizontal (Spread 30.7°)
0.25	51,440	40,257	20,129	14,761	104,669	39,363	56,360	0.13	0.14
0.50	18,550	14,517	7,259	5,323	37,745	14,195	20,324	0.26	0.27
1.00	5,110	3,999	2,000	1,466	10,398	3,910	5,599	0.52	0.55

⁵ Only available in sealed models with a glass window.
⁶ Only available in sealed model with glass window.

Dimensions

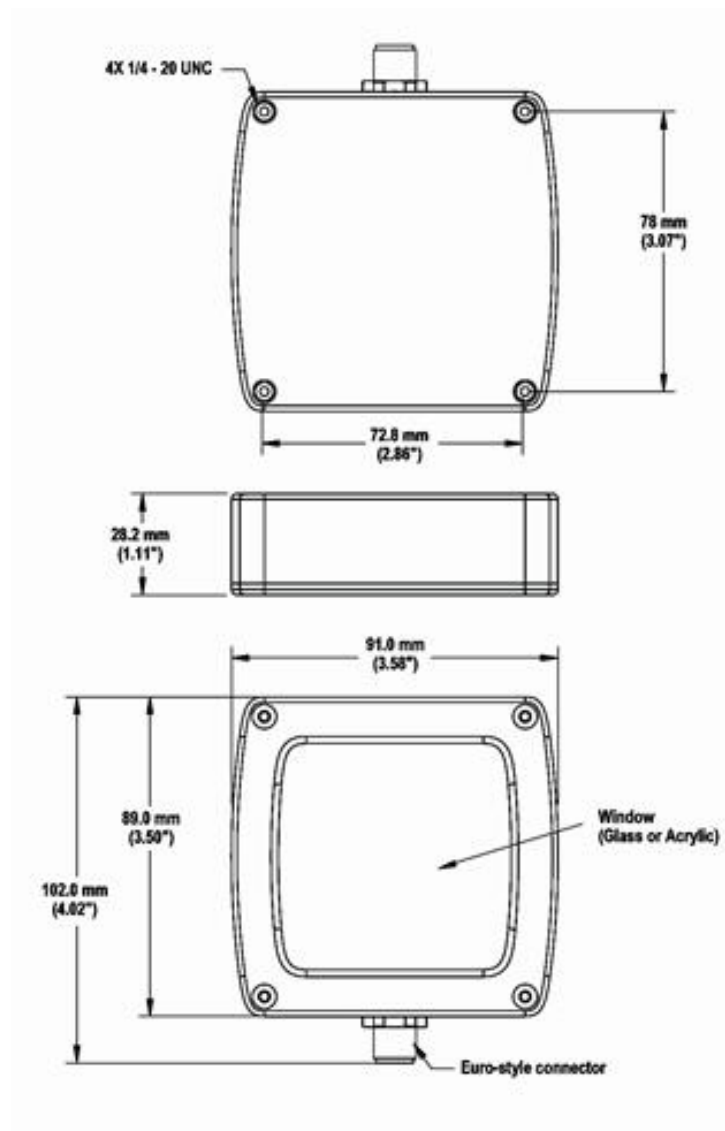

All measurements are listed in millimeters [inches], unless noted otherwise.

Accessories

The following describes available replacement window, cordset and bracket options for these lights.

Cordsets



Note: These 5-pin cordsets can also be used on 4-pin connector lights.

5-Pin Threaded M12/Euro-Style Cordsets				
Model	Length	Style	Dimensions	Pinout (Female)
MQDC20-506	1.83 m (6 ft)	Straight		
MQDC20-515	4.57 m (15 ft)			
MQDC20-530	9.14 m (30 ft)			

5-Pin Threaded M12/Euro-Style Cordsets—Stainless Steel Nut				
Model	Length	Style	Dimensions	Pinout (Female)
MQDC20SS-506	1.83 m (6 ft)	Straight		
MQDC20SS-515	4.57 m (15 ft)			
MQDC20SS-530	9.14 m (30 ft)			

Brackets

<p>SMBASCM</p> <ul style="list-style-type: none"> • 316 stainless steel column-mounting bracket with 430 stainless steel threaded insert • Four ¼-20 stainless steel screws included 		<p>SMBAMS70AS</p> <ul style="list-style-type: none"> • 316 stainless steel right-angle bracket • Articulated slots for 90+ degrees rotation • Four ¼-20 stainless steel screws included 	
---	--	---	--

Filters (Optional)

Light filters are available in red, white, blue, green, infrared, and other options. Visit <http://www.bannerengineering.com> to determine which filter is best for your application and Vision system.

Replacement Window Kits

Model	Description
LEDA70SW-P	Clear acrylic
LEDA70SW-G	Clear glass
LEDA70SCDW-P	Clear diffuse acrylic
LEDA70SWDW-P	White diffuse acrylic

Banner Engineering Corp. Limited Warranty

Banner Engineering Corp. warrants its products to be free from defects in material and workmanship for one year following the date of shipment. Banner Engineering Corp. will repair or replace, free of charge, any product of its manufacture which, at the time it is returned to the factory, is found to have been defective during the warranty period. This warranty does not cover damage or liability for misuse, abuse, or the improper application or installation of the Banner product.

THIS LIMITED WARRANTY IS EXCLUSIVE AND IN LIEU OF ALL OTHER WARRANTIES WHETHER EXPRESS OR IMPLIED (INCLUDING, WITHOUT LIMITATION, ANY WARRANTY OF MERCHANTABILITY OR FITNESS FOR A PARTICULAR PURPOSE), AND WHETHER ARISING UNDER COURSE OF PERFORMANCE, COURSE OF DEALING OR TRADE USAGE.

This Warranty is exclusive and limited to repair or, at the discretion of Banner Engineering Corp., replacement. **IN NO EVENT SHALL BANNER ENGINEERING CORP. BE LIABLE TO BUYER OR ANY OTHER PERSON OR ENTITY FOR ANY EXTRA COSTS, EXPENSES, LOSSES, LOSS OF PROFITS, OR ANY INCIDENTAL, CONSEQUENTIAL OR SPECIAL DAMAGES RESULTING FROM ANY PRODUCT DEFECT OR FROM THE USE OR INABILITY TO USE THE PRODUCT, WHETHER ARISING IN CONTRACT OR WARRANTY, STATUTE, TORT, STRICT LIABILITY, NEGLIGENCE, OR OTHERWISE.**

Banner Engineering Corp. reserves the right to change, modify or improve the design of the product without assuming any obligations or liabilities relating to any product previously manufactured by Banner Engineering Corp. Any misuse, abuse, or improper application or installation of this product or use of the product for personal protection applications when the product is identified as not intended for such purposes will void the product warranty. Any modifications to this product without prior express approval by Banner Engineering Corp will void the product warranties. All specifications published in this document are subject to change; Banner reserves the right to modify product specifications or update documentation at any time. Specifications and product information in English supersede that which is provided in any other language. For the most recent version of any documentation, refer to: www.bannerengineering.com.

For patent information, see www.bannerengineering.com/patents.