Micropower Step-up DC/DC Converter

FEATURES

- **Matched LED Current with Overvoltage Protection**
- **Drives up to 6 LEDs in series**
- **Up to 85% Efficiency**
- **Low 400mV Feedback Reference, Optional 1.19V Feedback Reference**
- **Internal Current Limit 300mA**
- **Under Voltage Lock Out Circuits**
- **0.1uA Low Shutdown Supply Current**
- **6-pin SOT-23 Package**
- **ESD Human Body Mode Over 5KV**

APPLICATIONS

- Cellular Phones
- Portable Communication Devices
- Handheld Electronics
- PDAs
- LED/Display Back Light Driver

PART NUMBER EXAMPLES

Part no.	Feedback Reference Voltage
T6309A-AX	400mV
T6309A-BX	1.19V

GENERAL DESCRIPTION

The T6309A is a step-up DC/DC converter that drives LED with a constant current. The device can driver up to 6 series LEDs from a single-cell Li-Ion battery. Series connection of the LEDs provides constant LED current that results in uniform brightness.

The T6309A features a minimum off-time current-limited PFM control scheme. The LED current is set with an external sense resistor (Rs) and is regulated by the feedback pin (FB) that regulates the voltage across the sense resistor to 400mV (typ). The low 400mV feedback reference voltage reduces power loss and improves efficiency for LED driver applications. Optional 1.19V feedback reference is available for normal output voltage applications like LCD bias. Output overvoltage protection (OVP) is integrated to prevent damage in case of output open circuit condition (e.g. faulty LED). The OVP pin can monitor the output voltage and turn off the converter in the event of overvoltage condition. The T6309A is available in SOT-23-6 packages.

PIN ARRANGEMENT
SOT23-6 (Top view)

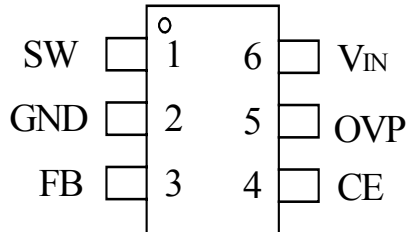

PIN DESCRIPTION

SYMBOL	Pin No.	DESCRIPTION
SW	1	Switch pin. Connect inductor/diode here. Minimize trace area at this pin to reduce EMI.
GND	2	Ground pin. Connect to local ground plane.
FB	3	Feedback pin. Reference voltage is 400mV (T6309A-A). Optional reference voltage is 1.19V (T6309A-B). Connect cathode of lowest LED and current sense resistor here.
CE	4	Chip enable pin. Tie CE pin to 1.5V or higher to enable device; 0.4V or less to shutdown the device. Do not float this pin.
OVP	5	Overvoltage protection. Connect his pin to the output capacitor of the converter.
VIN	6	Input supply pin. Must be locally bypassed.

BLOCK DIAGRAM

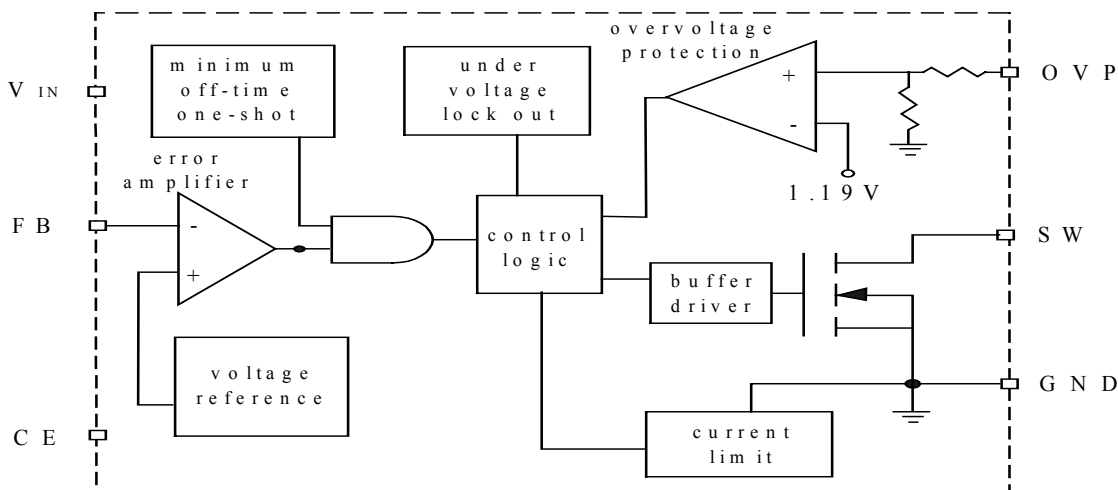

Fig. 1

Absolute Maximum Ratings

Supply Voltage	-0.3V to 5V
SW Pin Switch Voltage	-0.3V to 31V
OVP Pin Overvoltage Protection	-0.3V to 31V
CE Pin Voltage	-0.3V to (VDD+0.3V)
SW Pin Switch Current	300mA
Continuous power dissipation, PD @ TA = 25°C SOT-23-6	0.35W
Package Thermal Resistance SOT-23-6, θ_{JA}	150°C /W
Operating Junction Temperature	150°C
Operating temperature range	-40°C to +85°C
Storage temperature range, TSTG	-55°C to +150°C
Lead temperature (soldering, 10sec)	260°C
ESD Human Body Mode Over5KV

Electrical Characteristics

(VIN=+3V, TA = 25°C, unless otherwise noted)

Symbol	Description	Conditions	Min.	Typ.	Max	Unit
VIN	Input Voltage		2.5		5	V
VREF	Reference Voltage	T6309A-A	340	400	460	mV
		T6309A-B	1.15	1.19	1.23	V
TOFF	Switch Minimum Off Time		300	400	550	ns
VOVP	Over voltage Threshold			22		V
IDD2	Switch Off Current (VOUT)	FB=0.5V		60		uA
IOFF	Shutdown Current (VIN)	CE=0V		0.1	1	uA
VIHCE	CE Input Voltage Hight		1.5			V
VILCE	CE Input Voltage Low				0.4	
ICE	CE Input Bias Current				0.1	uA
IFB	FB Input Bias Current				0.1	uA
UVLO	Under Voltage Lockout		1.55	1.75	1.95	V
RDS(on)	Switch ON Resistance			0.6		ohm
ILIM	Current Limit			300		mA

Typical Operating Characteristics

(VIN=+3.3V, Load=4 LEDs, L=10uH, CIN=4.7uF, COU=4.7uF, T A=+25 °C, unless otherwise noted.)

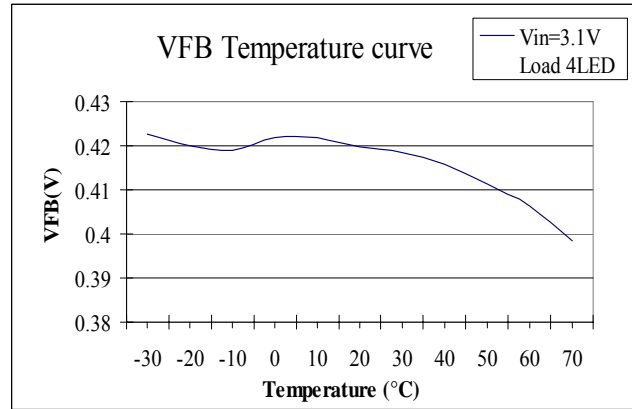
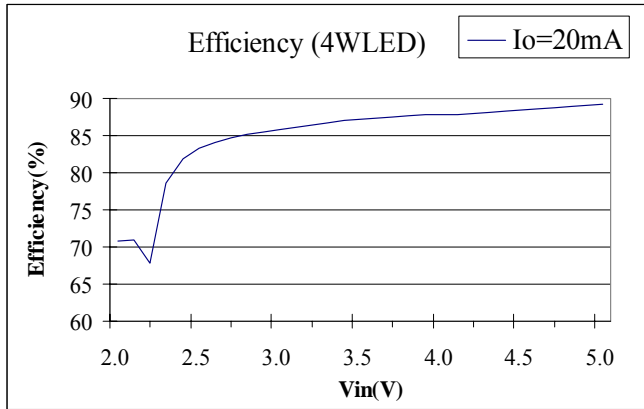

Stability for driving 4LED/ Vin=3.0V (time=1.0us/Div)

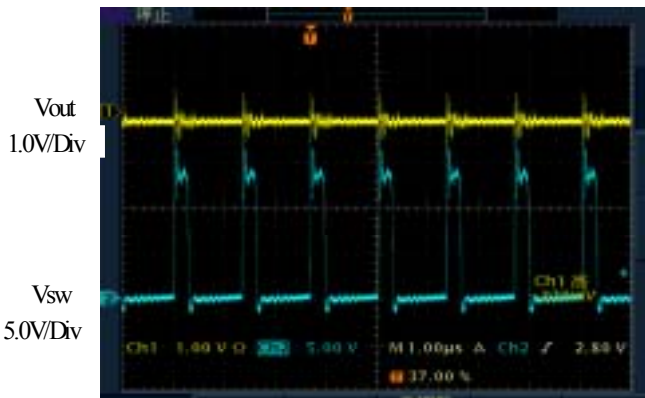

Stability for driving 4LED/ Vin=3.6V (time=1.0us/Div)

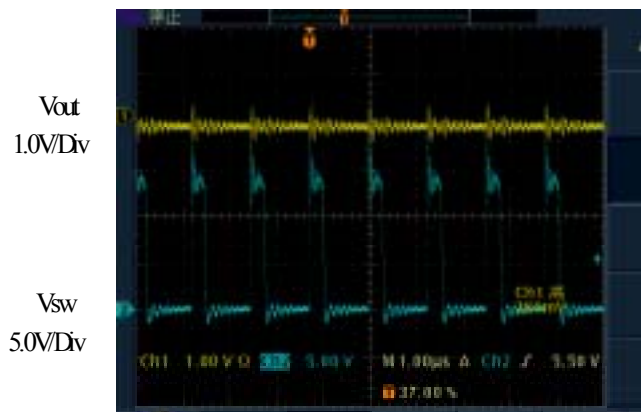

Stability for driving 4LED/ Vin=5.2V (time=1.0us/Div)

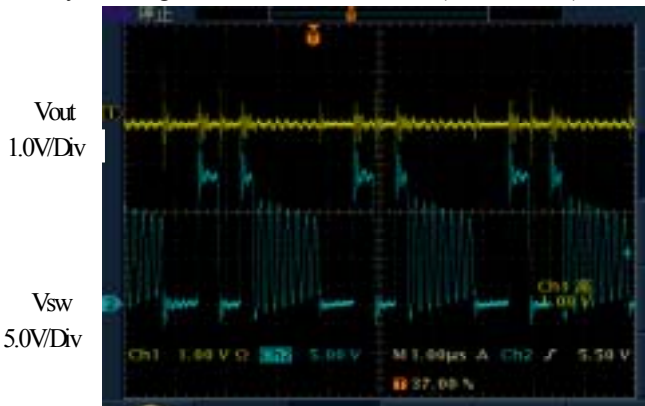

Typical Operating Characteristics

(VIN=+3.3V, Load=6 LEDs, L=10uH, CIN=4.7uF, COUT=4.7uF, T A=+25 °C, unless otherwise noted.)

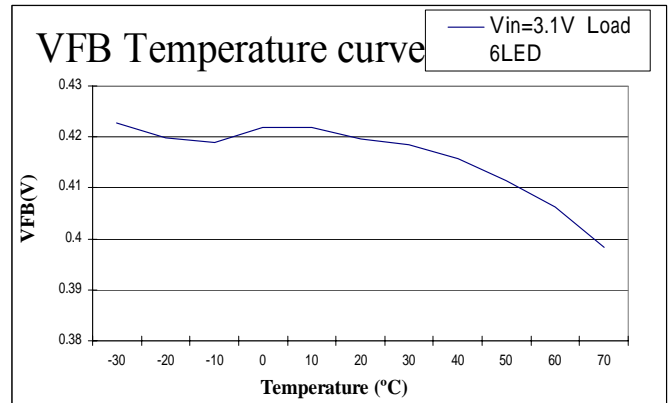
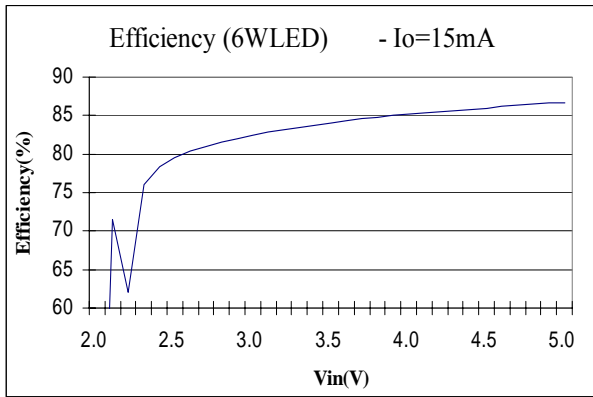

Stability for driving 6LED/Vin=3.0V

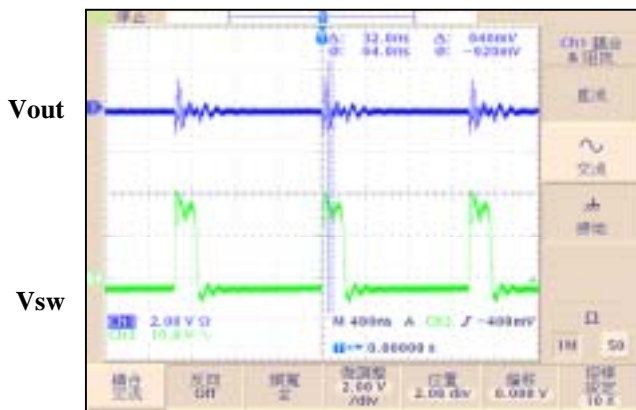

Stability for driving 6LED/Vin=3.6V

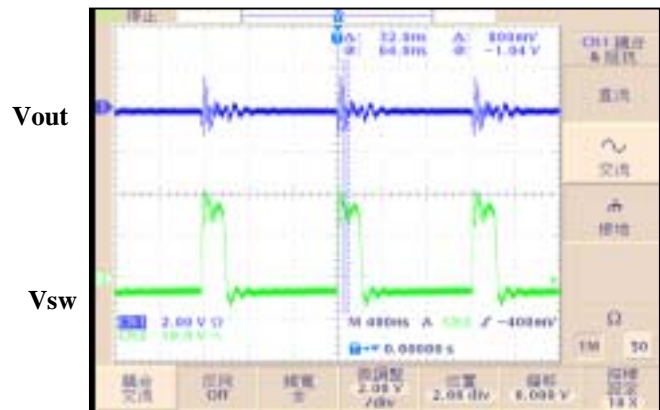

Stability for driving 6LED/Vin=5.2V

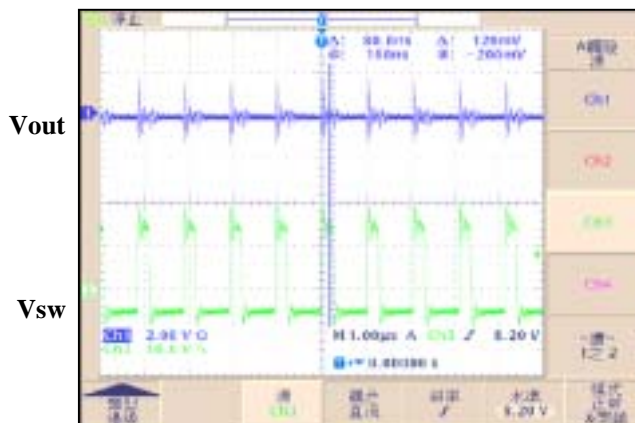

Functional Description

The T6309A is like a standard current-limit PFM step-up DC-DC converter, but regulates the voltage across the sense resistor R_s instead of the output voltage. This results in a constant LED current regardless the input voltage and number of LEDs connected. With integrated overvoltage protection (OVP), the T6309A can be used as a current source with overvoltage protection to drive LEDs. This allows up to 6 LEDs to be connected in series to the output. The low 400mV feedback reference voltage reduces power loss and improves efficiency.

Step-Up Converter

The step-up DC-DC converter operation can be understood by referring to the block diagram in Figure 1. PFM comparator monitors the output voltage via the sense resistor. When the feedback voltage is higher than the reference voltage, the MOSFET switch is turned off. As the feedback voltage is lower than reference voltage and the MOSFET switch has been off for at least a period of minimum off-time decided by the minimum off-time one-shot, the MOSFET switch is then turned on one-shot, or until the current limit signal is asserted.

During the internal MOSFET switch is turned on, current ramps up in the inductor and store energy in a magnetic field. When the MOSFET is turned off, the voltage across the inductor reverses and forces current through the diode to the output filter capacitor and load, so the energy in the inductor is

transferred to output filter capacitor and the load. As the energy stored in the inductor is depleted, the current ramps down and the output diode turns off. The output filter capacitor stores the charge while the inductor current is higher than the output current, then sustains the output voltage until the next switching cycle.

Current Limit

The T6309A utilizes cycle-by-cycle current limiting by means of protecting the output MOSFET switch from overstress and preventing the small value inductor from saturation. Current limiting is implemented by monitoring the output MOSFET current build-up during conduction, and upon sensing an over-current conduction immediately turning off the switch for the duration of the oscillator cycle. The current through the output MOSFET is monitored and compared against a reference signal. When the threshold is reached, a signal is sent to the PFM controller block to terminate the power switch conduction. The current limit threshold is typically set at 300mA.

Overvoltage Protection

Since T6309A is configured as current source, the output voltage rises as the output impedance increases or output is open-circuit (e.g. fault LED). The output voltage may exceed the 22 V maximum voltage rating of the internal main switch. An overvoltage protection circuit is integrated to prevent the main switch from burning. When the output

voltage exceeds the OVP threshold voltage, the main switch is turned off. It remains off until the output voltage falls below the OVP threshold voltage. The step-up converter continues normal operation as long as the output voltage is under the OVP threshold.

Shutdown

The T6309A enters shutdown to reduce quiescent current under 1uA when CE pin is low . For normal operation, drive CE high. During shutdown, the reference, all feedback and control circuitry are off. The boost converter's output drops to one Schottky diode voltage drop below the input voltage and SW remains high impedance. The capacitance and load at VOUT determine the rate at which VOUT decays. The CE pin can also be used as dimming control. More details are in the dimming control section.

Undervoltage Lockout

An undervoltage lockout (UVLO) circuit prevents fault operation of the T6309A when input voltage is under 1.75V (typ). The device remains off as long as the input voltage is under the UVLO threshold.

Applications Information

Dimming Control

There are several types of dimming control circuit as follows:

1. Using a PWM signal to CE pin

When using a PWM signal at CE pin, the T6309A is turned on or off by the PWM signal. The average LED current increases proportionally with the duty cycle of the PWM signal. The typical frequency range of the PWM signal is 150Hz to 250Hz. The magnitude of the PWM signal should be greater than the threshold voltage of CE voltage high.

2. Using a DC voltage

A DC voltage signal can be used as well to control the LED brightness. The dimming control method is shown in the figure below. When the DC voltage is zero, the LED is fully turned on. As the DC voltage increases, the voltage drop on R2 increases and the voltage drop on R1 decreases. Thus the LED current decreases. The selection of R1 and R2 should make the current from the variable DC source much smaller than the LED current and much larger than the FB pin bias current.

For V_{DC} range from 0V to 2V, the selection of resistors in this figure gives dimming control of LED current from 0mA to 15mA. Following steps are used to select the resistor values:

- Select the voltage V_{MAX} to turn the LEDs off. (e.g. 2.0V)
- Select 0V as default to turn the LEDs fully on.

- Select the maximum LED current I_{MAX} and 0mA as the minimum LED current.
- Calculate R2 to achieve a feedback current in the range of I_I = 3uA to 10uA as the LEDs are fully turned on:
R2 = V_{REF} / I_I (e.g. 0.4V/4uA =100KOhm)
- Calculate R1 to meet the equation:
R1 / (R1+R2) = V_{REF} / V_{MAX}
(e.g. V_{REF}=0.4V, V_{MAX}=2.0V, R2=100KOhm, the calculated R1 is 25KOhm)
- Calculate the sense voltage V_s at maximum LED current:
V_s = V_{REF} x (1 + R1/R2)
(e.g. V_s = 0.4V x (1 + 25K/100K) = 0.5V)
- Calculate the sense resistor R_s:
R_s = V_s / I_{MAX}
(e.g. 0.5V/20mA = 25 Ohm)

3. Using a Filtered PWM signal

The filtered PWM signal can be considered as an adjustable DC voltage. It can be used to replace the DC voltage source if adjustable analog signal is not available in the system. The circuit is shown in the figure below:

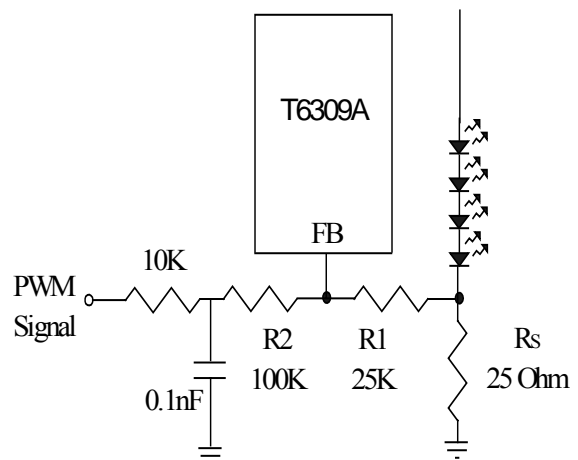

4. Using a Logic Signal

The LED current can be controlled in discrete steps with a logic signal as shown in the figure below. When the NMOS is off, R1 set the minimum current. When the NMOS is on, R2 sets the LED current increment value.

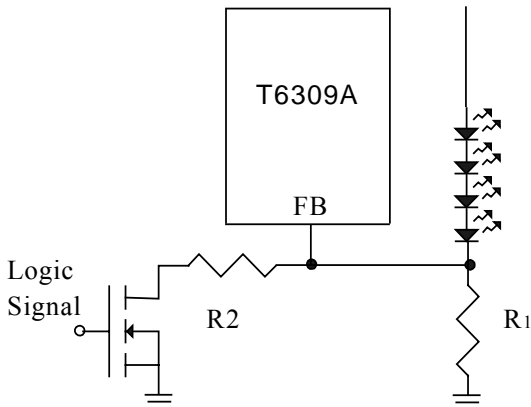

Start-Up and Inrush Current

The T6309A has no internal soft start circuit included to achieve minimum start-up delay. All inductive step-up converters have higher inrush current during start-up. The inrush current for T6309A is about 200mA. If soft-start is required, a recommended external circuit is shown in the below figure.

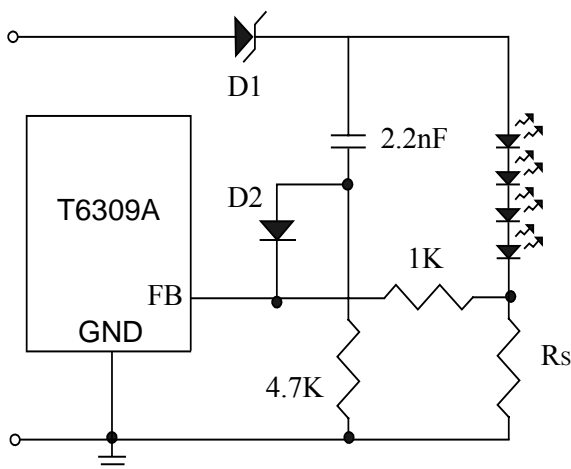

Output Voltage Selection

Referring to Fig. 4, select an output voltage for T6309A-B (1.19V reference) by connecting FB to a resistive divider between the output and GND. The V_{OUT} can be set as:
 $V_{OUT} = (1+R1/R2) \times 1.19V$

Higher R1,R2 values reduce quiescent current, but give bad noise immunity. To keep stable feedback loop operation and better noise immunity, select (R1+R2) value less than 1M Ω .

Inductor Selection

The T6309A is designed to work well with a 10uH inductor in most applications. Low inductance values supply higher output current, but also increase the ripple and reduce efficiency. Higher inductor values reduce ripple and improve efficiency, but also limit output current. Choose a low DC-resistance inductor, usually less than 1 Ω to minimize loss. It is necessary to choose an inductor with saturation current greater than the peak current that the inductor will encounter in the application. Saturation occurs when the inductor’s magnetic flux density reaches the maximum level the core can support and inductance falls. Inductor with 600mA rating or greater would be suitable for the T6309A.

Capacitor Selection

The input capacitor stabilizes the input voltage and minimizes the peak current ripple from the source. The value of the capacitor depends on the impedance of the input source

used. Small ESR (Equivalent Series Resistance) ceramic capacitor with value of 1 μ F to 4.7 μ F would be suitable.

The output capacitor is used to sustain the output voltage when the internal MOSFET is switched on and smoothing the ripple voltage. The larger the output ripple, the larger the line regulation, which means the LED current changes if the input voltage changes. Low ESR capacitor should be used to reduce output ripple voltage. Use a 4.7 μ F to 10 μ F ceramic output capacitor with about 50m Ω to 150m Ω ESR to provide stable switching and good line regulation.

Schottky Diode Selection

The diode is the largest source of loss in DC-DC converters. The most important parameters which affect the efficiency are the forward voltage drop, V_F , and the reverse recovery time. The forward voltage drop creates a loss just by having a voltage across the device while a current flowing through it. The reverse recovery time generates a loss when the diode is reverse biased, and the current appears to actually flow backwards through the diode due to the minority carriers being swept from the P-N junction. A Schottky diode with the following characteristics is recommended:

Small forward voltage, $V_F = 0.3$ V

Small reverse leakage current
Fast reverse recovery time/switching speed
Rated current larger than peak inductor current
Reverse

voltage larger than output voltage.

Layout Considerations

High switching frequencies make PC board layout a very important part of design. Good design minimizes excessive EMI on the feedback paths and voltage gradients in the ground plane, both of which can result in instability or regulation errors.

Connect the inductor, input filter capacitor, and output filter capacitor as close to the device as possible, and keep their traces short, direct, and wide to reduce power loss so as to improve efficiency. Connect their ground pins at a single common node in a star ground configuration, or at a full ground plane.

The output capacitor should be placed close to the output terminals to obtain better smoothing effect on the output ripple.

In addition, the ground connection for the sense resistor R_s should be tied directly to the GND pin and not shared with any other component. This ensures a clean, noise-free connection.

TYPICAL APPLICATION CIRCUITS

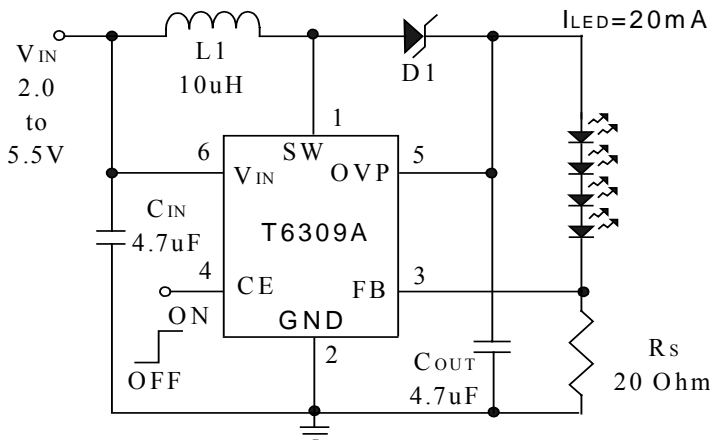

Fig. 2 Typical application for driving 4 white LEDs

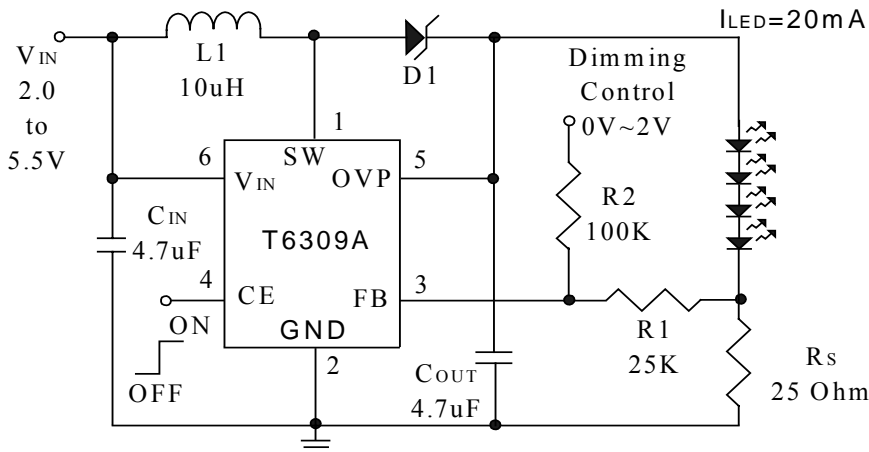

Fig. 3 White LED application with DC voltage dimming control

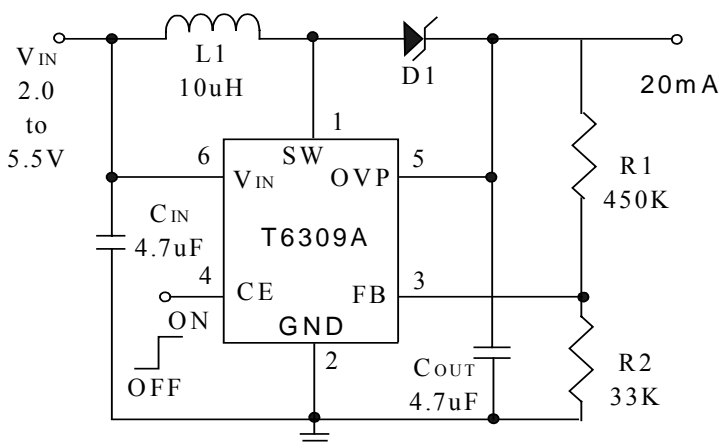

Fig. 4 Typical application for line drivers or LCD bias

TYPICAL APPLICATION CIRCUITS

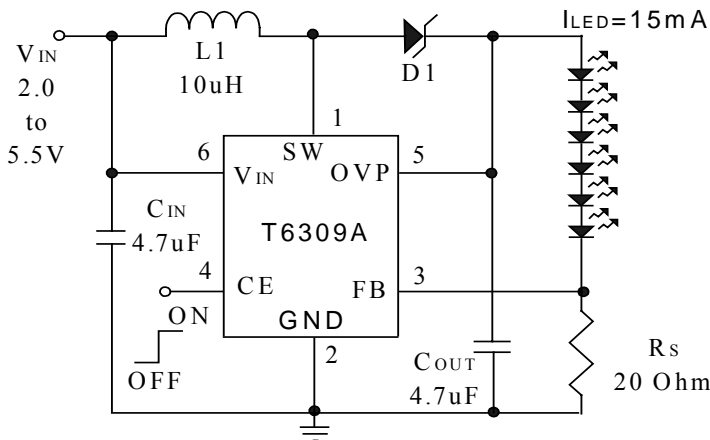

Fig. 5 Typical application for driving 6 white LEDs

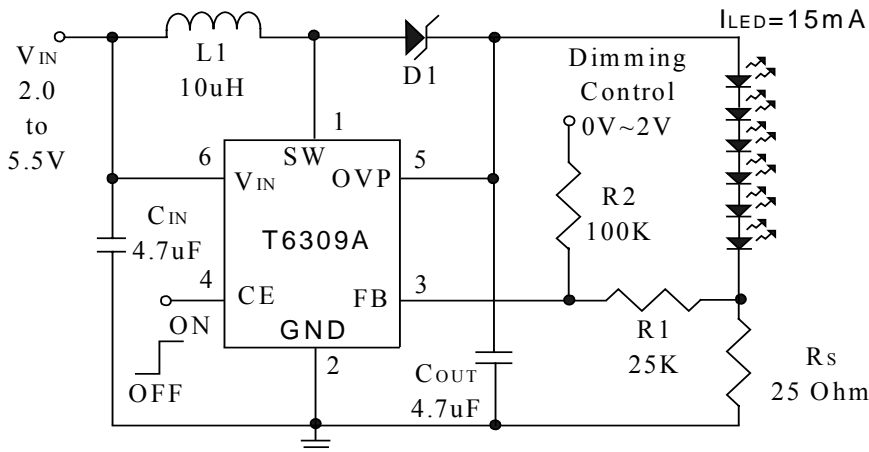

Fig. 6 White LED application with DC voltage dimming control

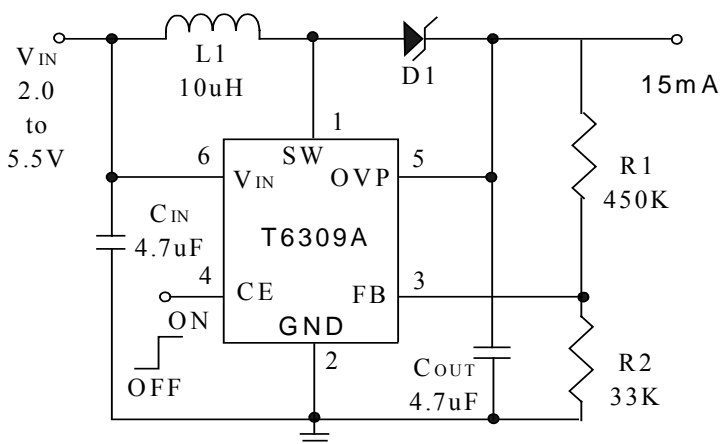
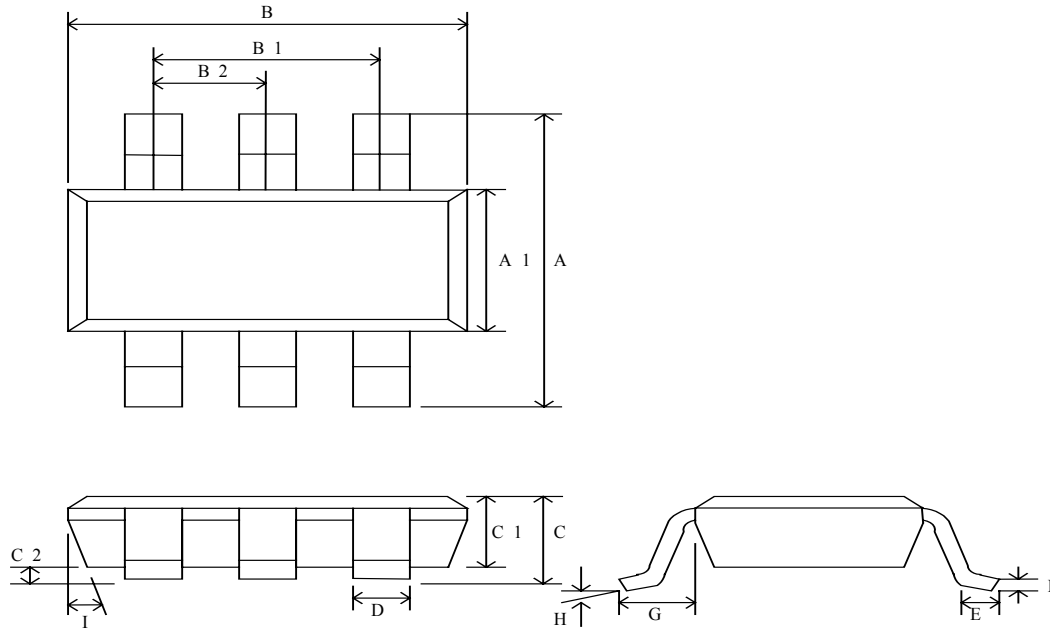

Fig. 7 Typical application for line drivers or LCD bias

PACKAGE DIMENSIONS
SOT23-6



Symbol	Dimension in mm			Dimension in inch		
	Min.	Typ.	Max.	Min.	Typ.	Max.
A	2.60	2.80	3.00	0.102	0.110	0.118
A1	1.40	1.575	1.60	0.055	0.062	0.063
B	2.70	2.85	3.00	0.106	0.112	0.118
B1		1.90(BSC)			0.075(BSC)	
B2		0.95(BSC)			0.037(BSC)	
C	0.95	1.20	1.45	0.037	0.047	0.057
C1	0.90	1.10	1.30	0.035	0.043	0.051
C2	0	0.075	0.150	0	0.003	0.06
D		0.40			0.015	
E	0.30	0.45	0.60	0.012	0.018	0.023
F	0.08	0.15	0.22	0.003	0.006	0.009
G		0.60(REF)				
H				0~8°		
I	5~15°			5~15°		