

Rev	AWO #	Description	Date	Appr
-	9427	RELEASED	3/06/09	

APPROVED: \_\_\_\_\_  
 DATE: \_\_\_\_\_ TITLE: \_\_\_\_\_

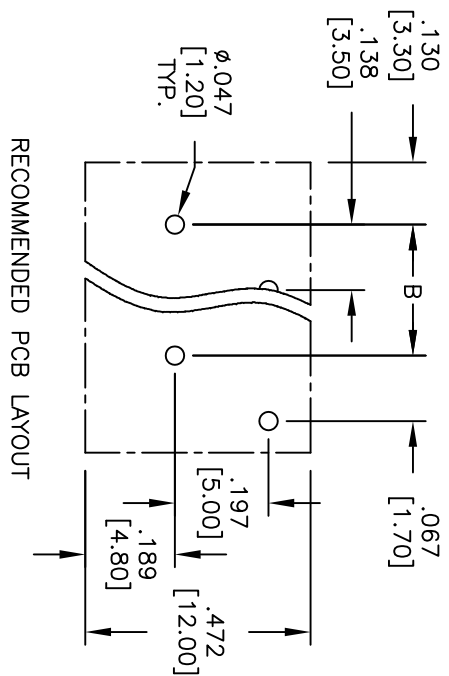
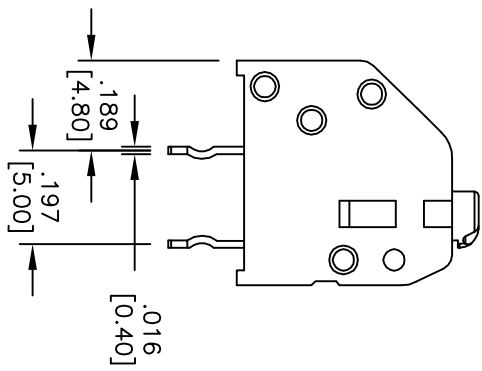
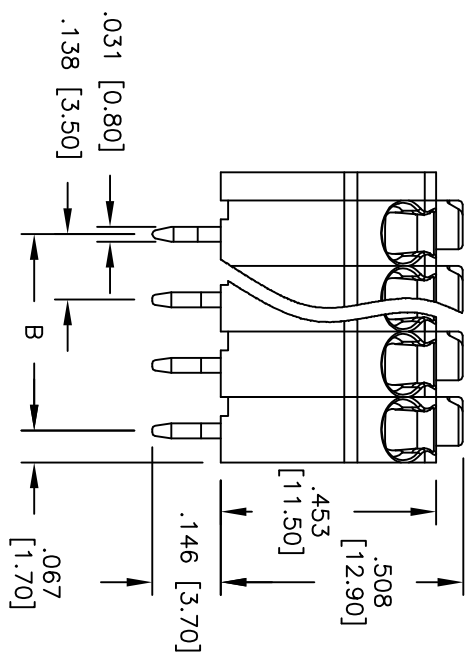
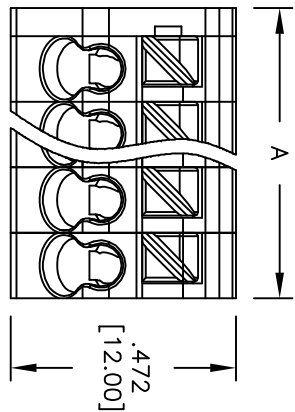

Poles: 2 thru 24  
 A = .138 [3.50] x No. of Poles + .059 [1.50]  
 B = .138 [3.50] x No. of Spaces

**SPECIFICATIONS:**  
 Material: Insulator: PA66, rated UL 94V-0  
 Insulator color: Gray  
 Contact: Bronze, Tin plated  
 Electrical: Operation voltage: 300 VAC max  
 Current rating: 6 Amps max per Pole  
 Mechanical: Solid wire: 20-16 AWG  
 Environmental: Operating temperature: -30°C to +105°C  
 Lead free, RoHS compliant.  
 Recommended soldering temp: 235°C for 5 sec.



UNLESS OTHERWISE SPECIFIED ALL DIMENSIONS ARE INCHES [MM]	
TOLERANCES: EXCEPT AS NOTED	
INCHES	HOLES
.X ± .10	ØXX ± .10
.XX ± .020	ØXXX ± .015
.XXX ± .015	ØXXXX ± .010
APPROVALS	DATE
DRAWN	DY
CHECKED	
APPROVED	

**ADAM TECH**  
 909 Rainway Avenue, Union, NJ 07083  
 Phone: 908-687-5000 Fax: 908-687-5710

TITLE: MINI TYPE, SIMPLE TYPE CAGE CLAMP TERMINAL BLOCKS,  
 3.50MM PITCH

SIZE	PART NO.	REV.
X	EB59-XX-A	-
REF:	S00007T	SCALE: NTS
SHEET	1	OF 1

6 5 4 3 2 1