

THIS DRAWING IS UNPUBLISHED. RELEASED FOR PUBLICATION 20  
 © COPYRIGHT 20 BY - ALL RIGHTS RESERVED.

LOC		DIST		REVISIONS			
P	LTR	DESCRIPTION	DATE	DWN	APVD		
A		ECR-18-011462	23JUL2018	SR	DD		
A1		ECO-18-014097	06SEP2018	GCM	DD		
A2		ECR-18-016855	26OCT2018	SR	DD		
A3		ECR-18-017279	06NOV2018	SR	DD		

SEE SHEET 2 FOR WIRING COLOR CODE

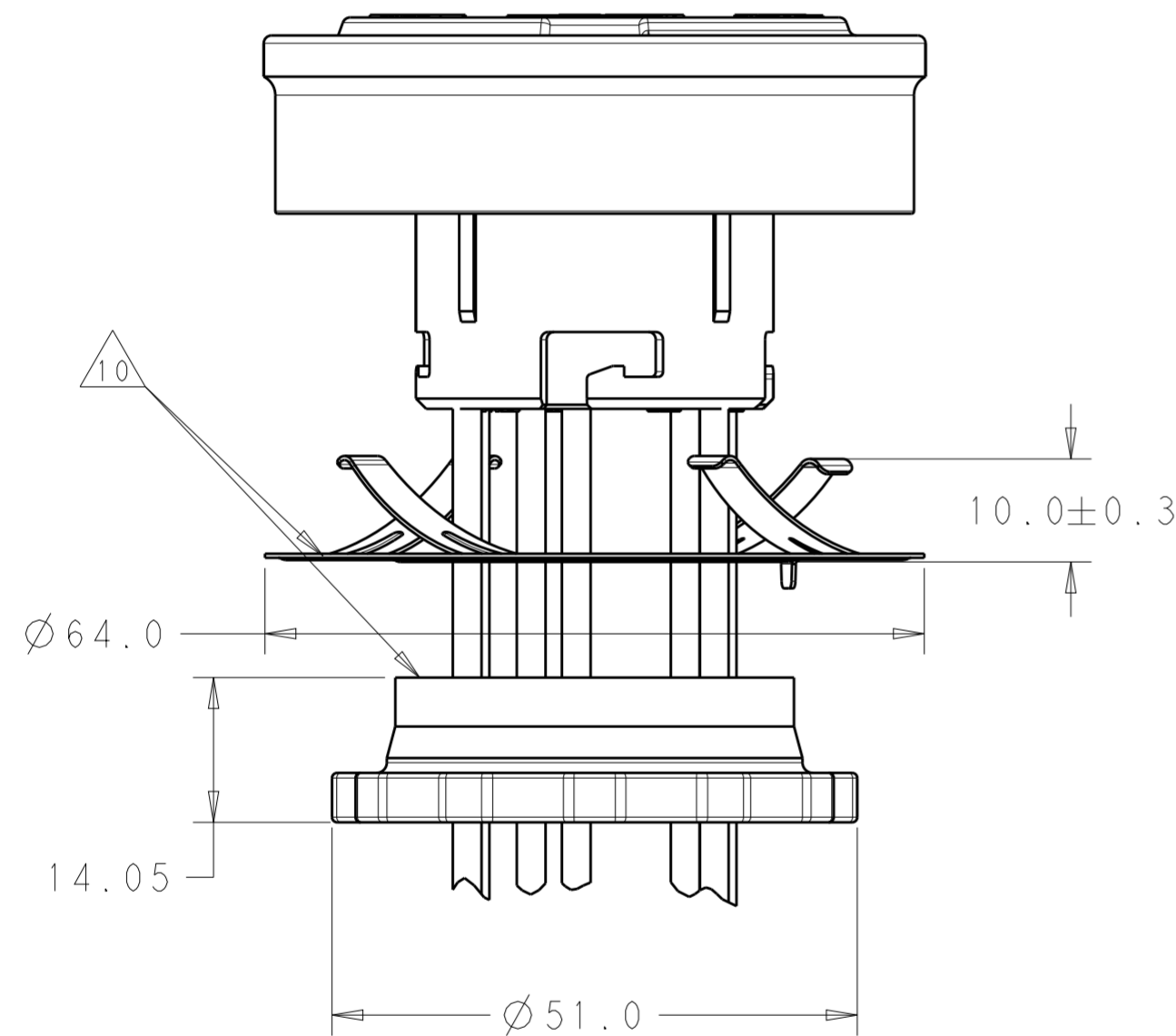
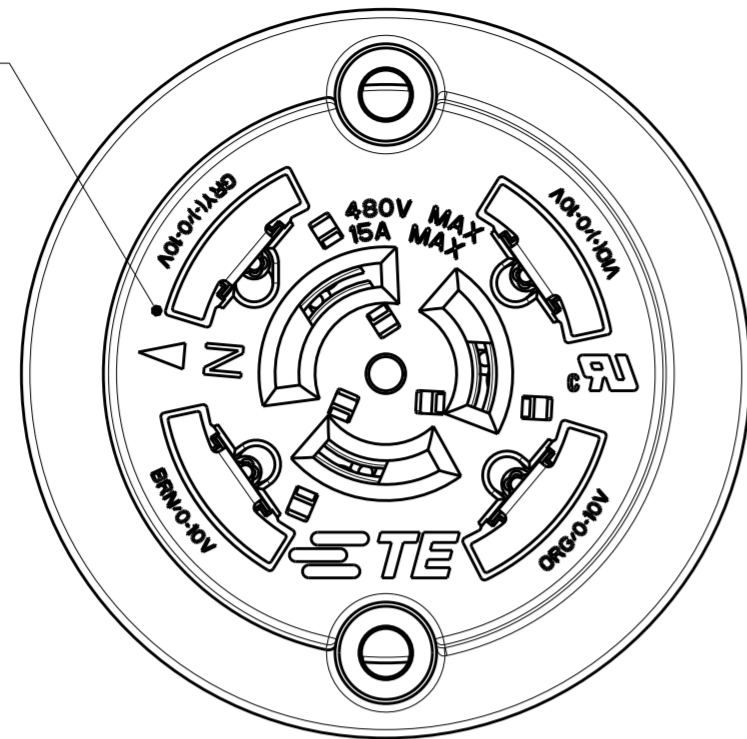

NOTES:

1. MATERIALS:  
 HOUSING: GLASS-FILLED THERMOPLASTIC, UL 94V-0 RATED  
 DIMMING CONTACTS (2 OR 4): COPPER ALLOY  
 LINE VOLTAGE CONTACTS (3): COPPER ALLOY  
 SPRING PLATE: STAINLESS STEEL  
 LOCKING RING: PBT
2. FINISH:  
 DIMMING CONTACTS (2 OR 4): NICKEL UNDERPLATE ENTIRE CONTACT  
 0.127 µm MIN THICK. GOLD PLATE CONTACT PAD AREA (MATING FACE SIDE ONLY) 0.76 µm MIN THICK. MATTE TIN PLATE TAB ON BOTH SIDES  
 0.30 µm MIN THICK.  
 LINE VOLTAGE CONTACTS (3): TIN PLATE.
3. LINE VOLTAGE CONDUCTORS (3):  
 14 AWG, 600V, 150°C RATED, COPPER 41/30 STRANDED  
 PER UL STYLE AWM 3321.
4. MATING INTERFACE PER ANSI C136.41-2013.
5. OPTIONAL DIMMING CONTACTS (2) SUPPLIED.
6. DIMMING CONDUCTORS (2 OR 4):  
 18 AWG, 600V, 150°C RATED, 16/30 STRANDED,  
 PER UL STYLE AWM 3321.
7. LINE VOLTAGE CONDUCTORS (3):  
 14 AWG, 600V, 105°C RATED, COPPER 41/30 STRANDED.  
 PER UL STYLE AWM 1015.
8. DIMMING CONDUCTORS (2 OR 4):  
 18 AWG, 600V, 105°C RATED, COPPER 16/30 STRANDED.  
 PER UL STYLE AWM 1015.
9. MUST COMPLY WITH DIRECTIVE 2002/95/EC (ROHS)
10. LOCKING RING (REF P/N: 2333095-1) AND  
 SPRING PLATE (REF P/N: 2333094-1) NOT ASSEMBLED,  
 SHIPPED BULK PACKED
11. MUST BE USED WITH GASKET (REF P/N: 2332473-1) SOLD SEPARATELY

304.8	291.3	7 AND 8	4 5	2-2332966-4
304.8	291.3	7 AND 8	2	2-2332966-3
304.8	291.3	3 AND 6	4 5	2-2332966-2
304.8	291.3	3 AND 6	2	2-2332966-1
A	B	WIRE STYLE	QUANTITY OF DIMMING CONTACTS	PART NO.
WIRE LENGTH				

THIS DRAWING IS A CONTROLLED DOCUMENT.		DWN C. DAILY 15MAR2018	TE Connectivity	
		CHK E. HOWARD 15MAR2018		
DIMENSIONS: mm		TOLERANCES UNLESS OTHERWISE SPECIFIED:		NAME RECEPTACLE ASSEMBLY, LUMAWISE ENDURANCE N TOOL-LESS ROTATABLE
		0 PLC ±	PRODUCT SPEC 108-133114	SIZE A2
		1 PLC ±0.2	APPLICATION SPEC 114-133114	CAGE CODE 00779
		2 PLC ±0.13	WEIGHT	DRAWING NO C-2332966
		3 PLC ±		RESTRICTED TO
		4 PLC ±		
MATERIAL		ANGLES ±1°		
		FINISH		
			CUSTOMER DRAWING	SCALE 1:1 SHEET 1 OF 3 REV A3

THIS DRAWING IS UNPUBLISHED. RELEASED FOR PUBLICATION 20  
 © COPYRIGHT 20 BY - ALL RIGHTS RESERVED.

LOC		DIST		REVISIONS			
P	LTR	DESCRIPTION	DATE	DWN	APVD		
-	-	SEE SHEET 1	-	-	-		

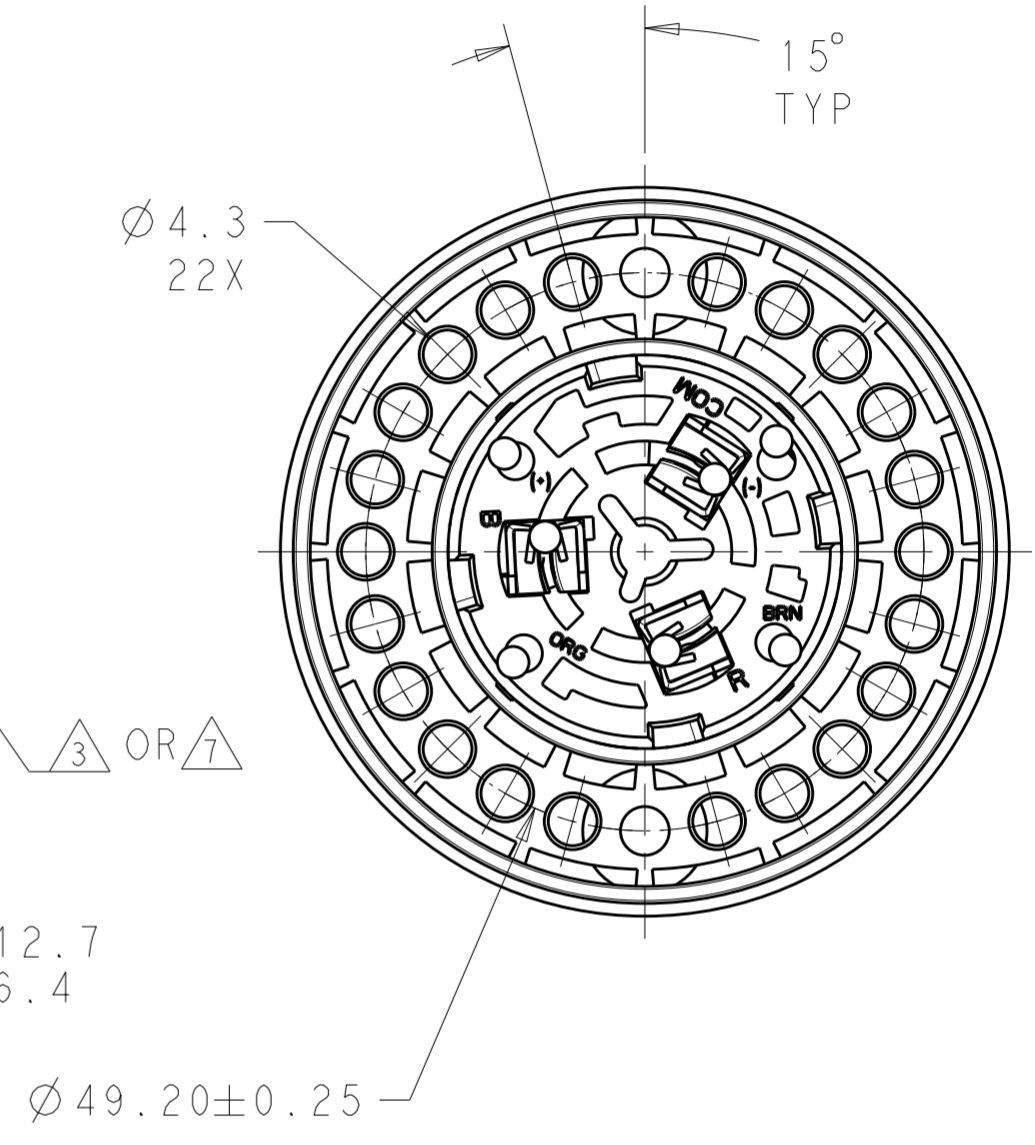
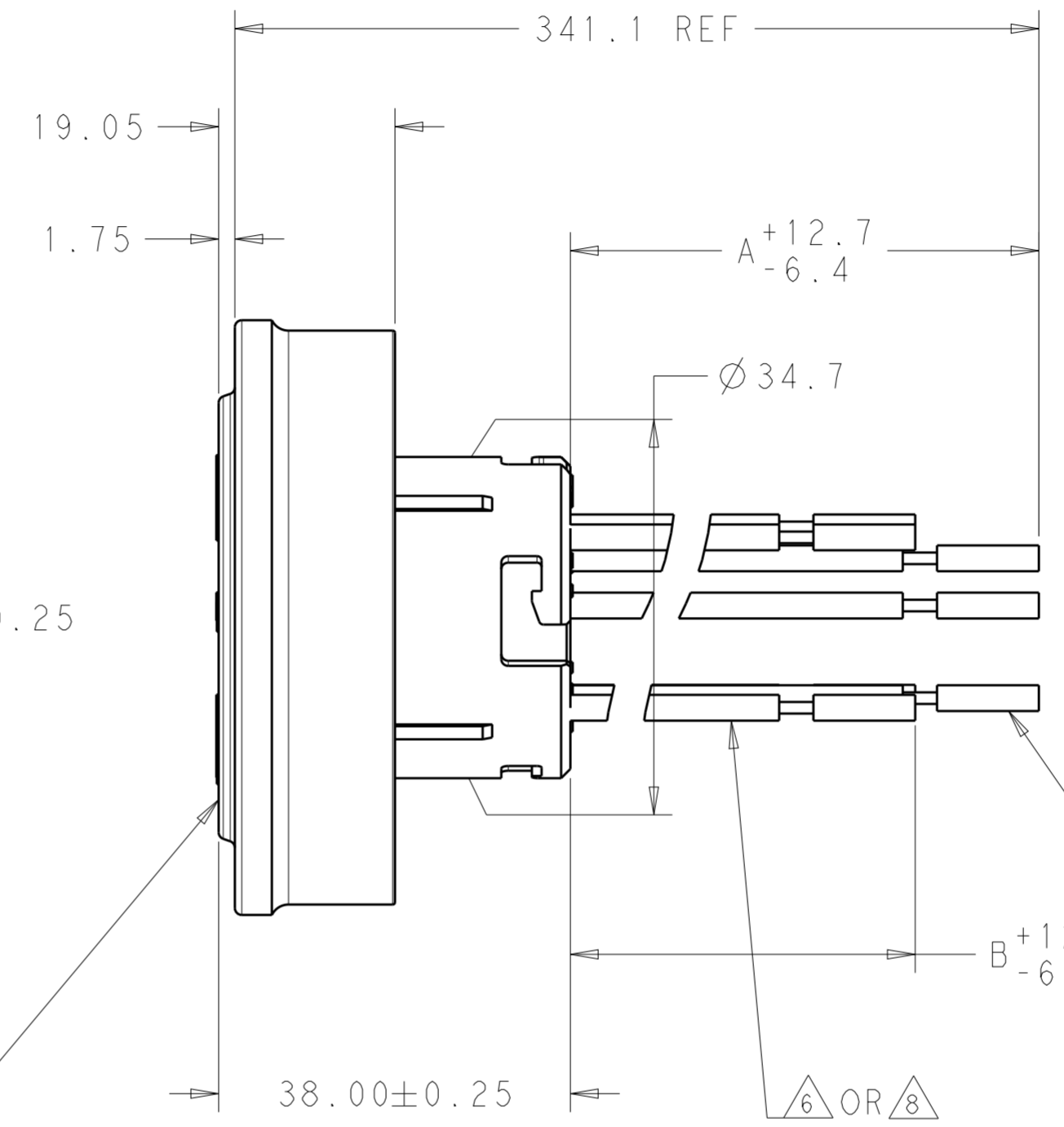
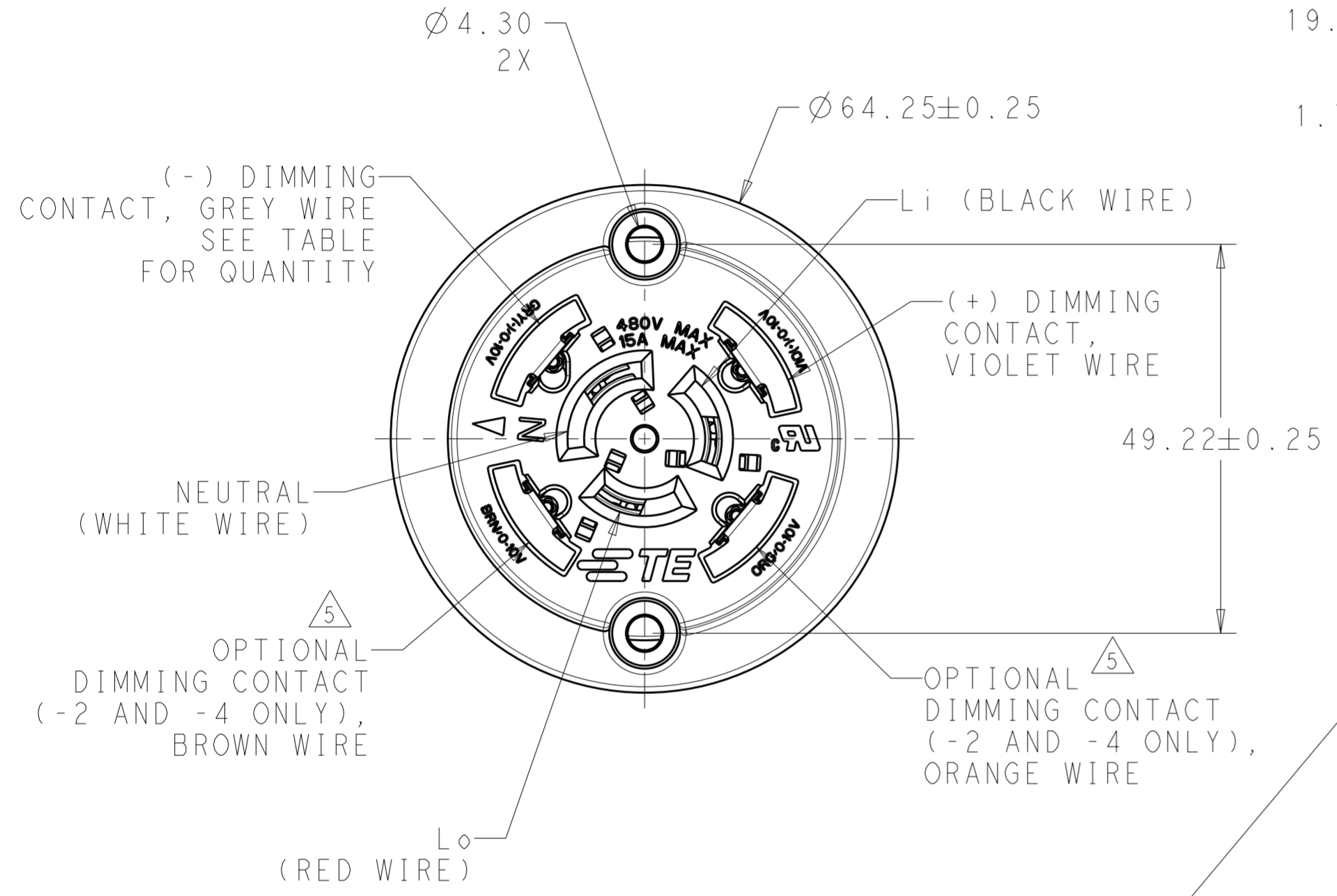

THIS DRAWING IS A CONTROLLED DOCUMENT.		DWN C. DAILY 15MAR2018	TE Connectivity	
		CHK E. HOWARD 15MAR2018		
DIMENSIONS:		APVD -	NAME RECEPTACLE ASSEMBLY, LUMAWISE ENDURANCE N TOOL-LESS ROTATABLE	
mm		PRODUCT SPEC 108-133114	SIZE A2	
TOLERANCES UNLESS OTHERWISE SPECIFIED:		APPLICATION SPEC 114-133114	CAGE CODE 00779	DRAWING NO C-2332966
0 PLC ±		WEIGHT -	RESTRICTED TO -	
1 PLC ±0.2		CUSTOMER DRAWING		
2 PLC ±0.13		SCALE 1:1		
3 PLC ±		SHEET 2 OF 3		
4 PLC ±		REV A3		
ANGLES ±1°				
FINISH				

THIS DRAWING IS UNPUBLISHED. RELEASED FOR PUBLICATION 20  
 © COPYRIGHT 20 BY - ALL RIGHTS RESERVED.

LOC		DIST		REVISIONS			
P	LTR	DESCRIPTION	DATE	DWN	APVD		
-	-	SEE SHEET 1	-	-	-		

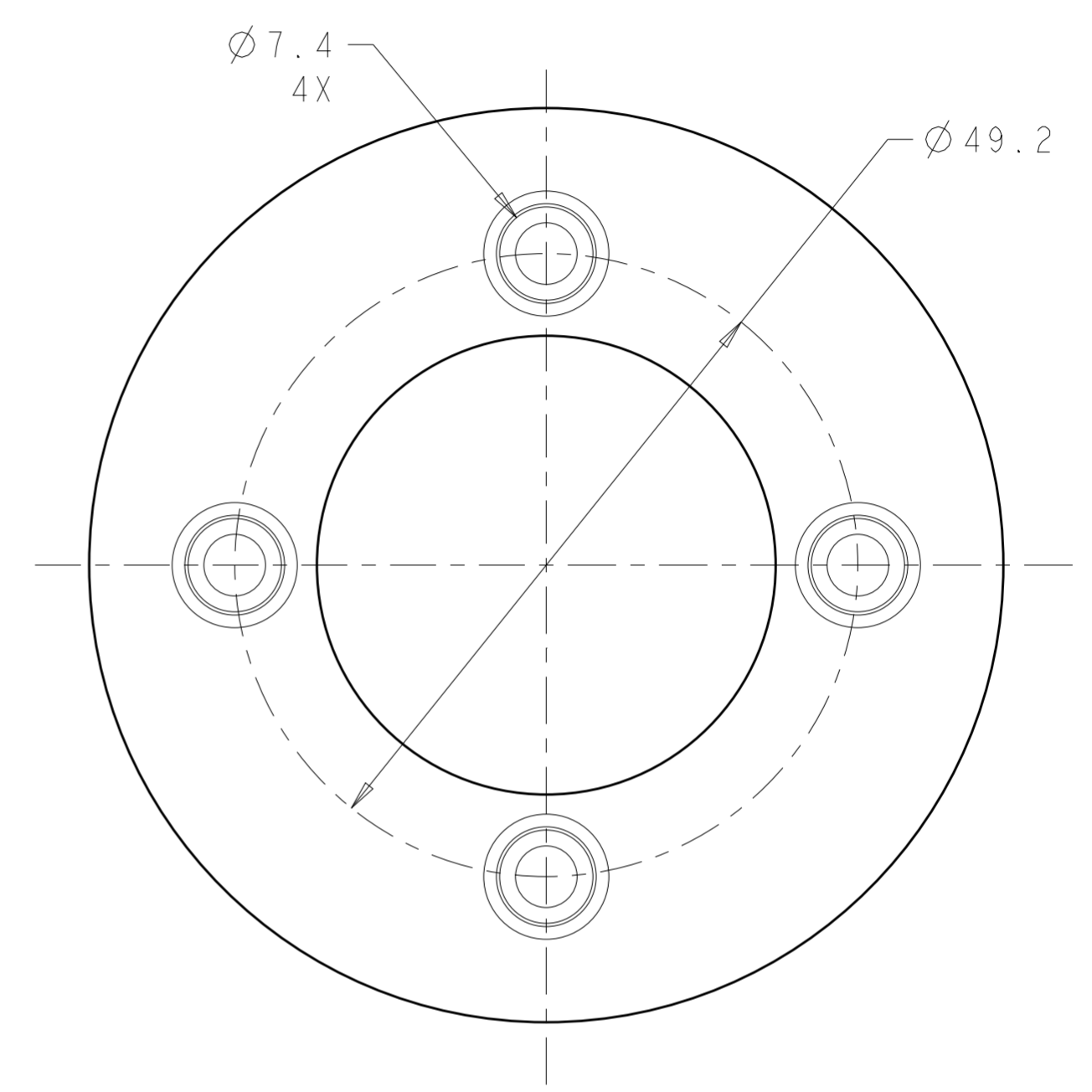
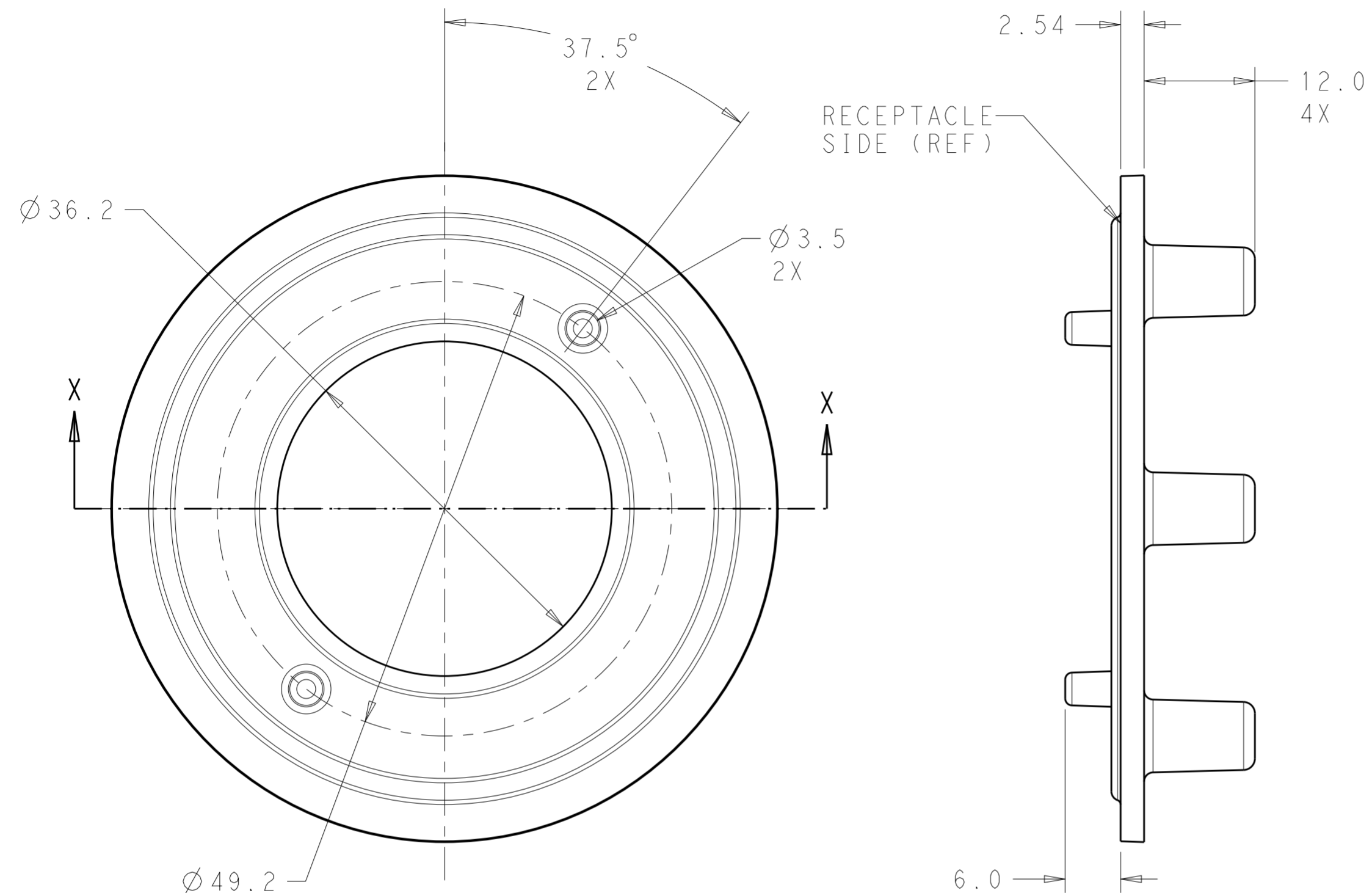

RECOMMENDED MOUNTING LAYOUT  
 SCALE 2:1

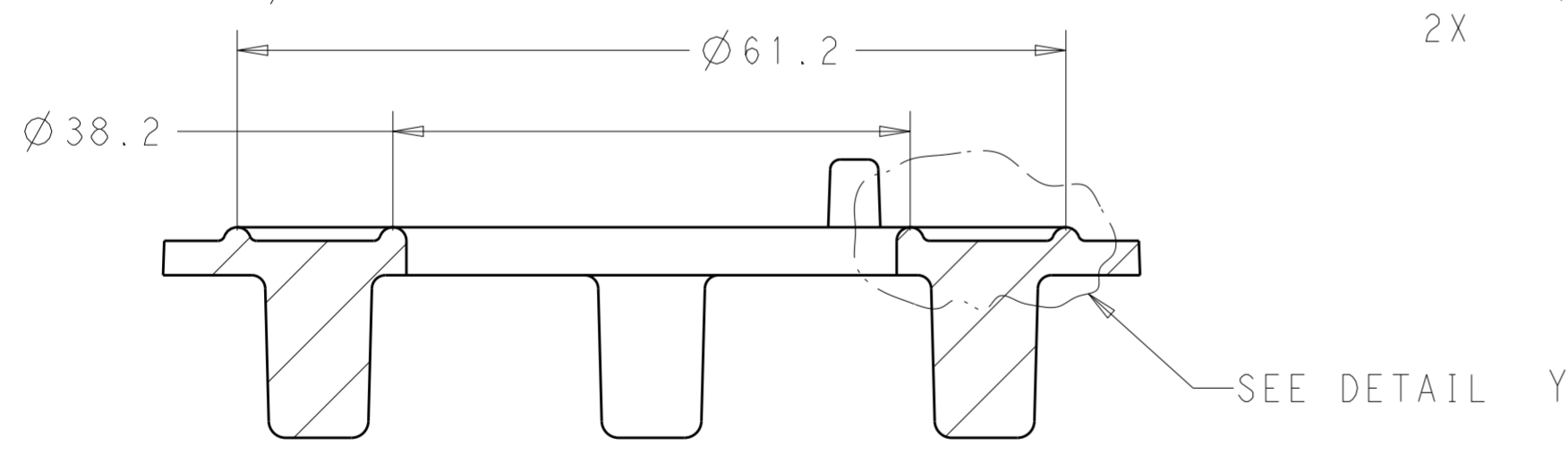

SECTION X-X

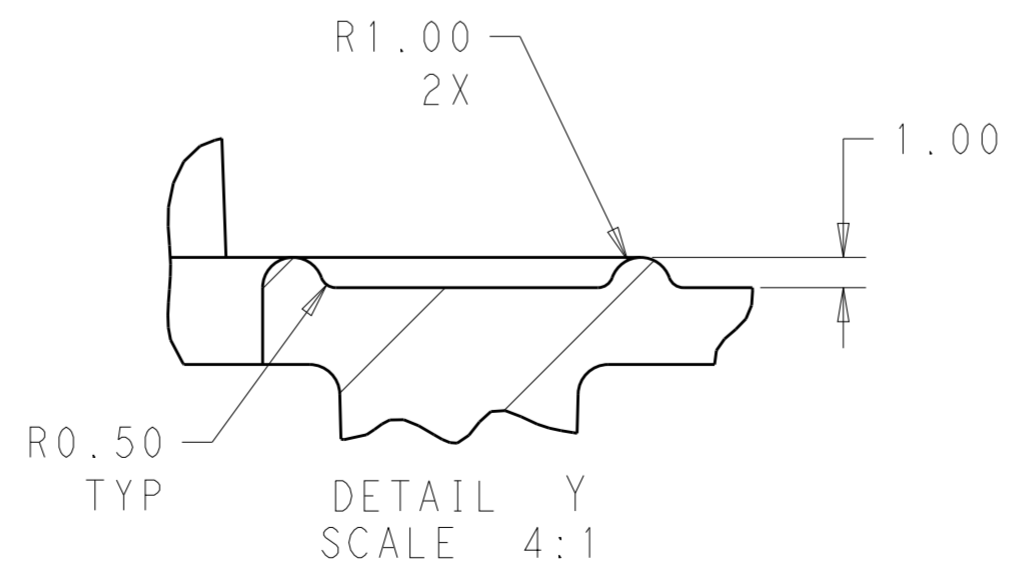

DETAIL Y  
 SCALE 4:1

THIS DRAWING IS A CONTROLLED DOCUMENT.		DWN C. DAILY 15MAR2018	TE Connectivity	
		CHK E. HOWARD 15MAR2018		
DIMENSIONS: mm		APVD -	NAME RECEPTACLE ASSEMBLY, LUMAWISE ENDURANCE N TOOL-LESS ROTATABLE	
TOLERANCES UNLESS OTHERWISE SPECIFIED:		PRODUCT SPEC 108-133114	RESTRICTED TO	
0 PLC ±-		APPLICATION SPEC 114-133114	SIZE A2	CAGE CODE 00779
1 PLC ±0.2		WEIGHT -	DRAWING NO C-2332966	SCALE 1:1
2 PLC ±0.13		CUSTOMER DRAWING	SHEET 3	OF 3
3 PLC ±-			REV A3	
4 PLC ±-				
ANGLES ±1°				
FINISH				