

PRODUCT SPECIFICATION

SPEC. NO: T-0620-001T

DATE: Aug. 21, 2018

CUSTOMER'S PRODUCT NAME:

EMTEK PRODUCT NAME:

HEC1008-SERIES

THIS SPECIFICATION IS:

- FULLY ACCEPTED
- DENIED
- ACCEPTED UNDER THE FOLLOWING CONDITIONS



SIGNATURE: _____

DATE: _____

NAME(PRINT): _____

TITLE: _____

 **EMTEK CO., LTD.**

本文件內容全部或部份,未經兆欣科技股份有限公司同意不得以任何形式複製或其他用途
All rights reserved.This document or parts thereof,may not be reproduced by any means or used in any manner without written permission of EMTEK CO.,LTD.

FACTORY:

39, Chingao Rd., (305)Hsinpu,
Hsinchu Hsien, Taiwan, R. O. C
TEL: 03-5894-433
FAX: 03-5894-523

PRODUCT SPECIFICATION

SPEC. NO.

T-0620-001T



1. Scope

This specification applies Ceramic Chip Inductance HEC1008-Series to be delivered to user.

2. Product Identification

HEC 1008 - 10N □ - T

(1) (2) (3) (4) (5)

(1) Product name

(2) Shapes and dimensions

(3) Inductance

10N : 10 nH

(4) Tolerance

G=±2% , J=±5% , K=±10%

(5) Taping Type

3. Shapes and Dimensions

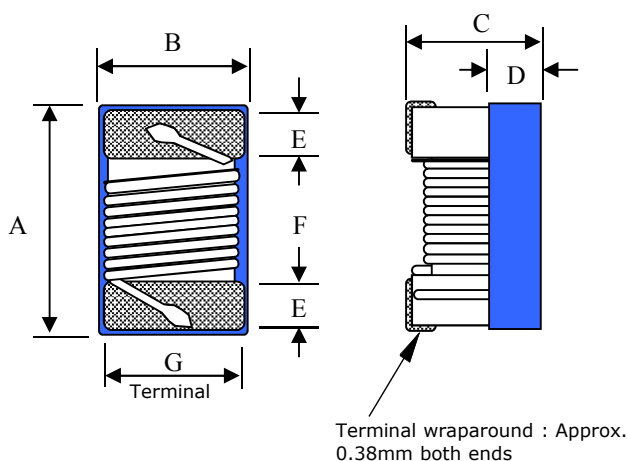

A max. : 2.90 mm

B max. : 2.54 mm

C max. : 2.03 mm

D ref. : 1.30 mm

E : 0.45 ± 0.1 mm

F : 1.60 ± 0.1 mm

G : 2.0 mm

Equivalent circuit

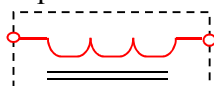

No Polarity

Drawn by	Checked by	Approved by
Cindy Aug. 8. 2016	Zheng Aug. 8. 2016	Lu Aug. 8. 2016

PRODUCT SPECIFICATION

SPEC. NO.

T-0620-001T

**4. Electrical Characteristics**

Customer Part Number	Our Product Part Number	Inductance (nH)/MHz	Inductance Tolerance	Q/MHz Min.	SRF(Min.) (MHz)	Rdc (Ω)Max.	Irms Max. (mA)	Color Coding		
								1st	2nd	3rd
	HEC1008-4N2□-T	4.2/50	J K	30/500	4300	0.065	1000	Black	Yellow	Violet
	HEC1008-4N7□-T	4.7/50	J K	30/500	4300	0.065	1000	Black	Yellow	Violet
	HEC1008-5N6□-T	5.6/50	J	20/500	4200	0.24	1000	Black	Green	Blue
	HEC1008-8N2□-T	8.2/50	J K	40/500	4100	0.070	1000	Gray	Yellow	Violet
	HEC1008-10N□-T	10/50	G J K	50/500	4100	0.08	1000	Brown	Black	Black
	HEC1008-12N□-T	12/50	G J K	50/500	3300	0.09	1000	Brown	Red	Black
	HEC1008-15N□-T	15/50	G J K	50/500	2500	0.16	1000	Brown	Green	Black
	HEC1008-18N□-T	18/50	G J K	50/350	2500	0.11	1000	Brown	Gray	Black
	HEC1008-22N□-T	22/50	G J K	55/350	2400	0.12	1000	Red	Red	Black
	HEC1008-27N□-T	27/50	G J K	50/350	1600	0.13	1000	Red	Violet	Black
	HEC1008-33N□-T	33/50	G J K	60/350	1600	0.14	1000	Orange	Orange	Black
	HEC1008-36N□-T	36/50	G J K	60/350	1600	0.15	1000	Orange	Blue	Black
	HEC1008-39N□-T	39/50	G J K	60/350	1500	0.15	1000	Orange	White	Black
	HEC1008-43N□-T	43/50	G J K	65/350	1500	0.16	1000	Yellow	Orange	Black
	HEC1008-47N□-T	47/50	G J K	65/350	1500	0.16	1000	Yellow	Violet	Black
	HEC1008-56N□-T	56/50	G J K	65/350	1300	0.18	1000	Green	Blue	Black
	HEC1008-68N□-T	68/50	G J K	65/350	1300	0.20	1000	Blue	Gray	Black

PRODUCT SPECIFICATION

SPEC. NO.

T-0620-001T

**4. Electrical Characteristics**

Customer Part Number	Our Product Part Number	Inductance (nH)/MHz	Inductance Tolerance	Q/MHz Min.	SRF(Min.) (MHz)	Rdc (Ω)Max.	Irms Max. (mA)	Color Coding		
								1st	2nd	3rd
	HEC1008-75N□-T	75/50	G	60/350	1000	0.21	1000	Violet	Green	Black
			J							
			K							
	HEC1008-82N□-T	82/50	G	60/350	1000	0.22	1000	Gray	Red	Black
			J							
			K							
	HEC1008-91N□-T	91/50	G	60/350	1000	0.28	1000	White	Brown	Black
			J							
			K							
	HEC1008-R10□-T	100/25	G	60/350	1000	0.56	650	Brown	Black	Brown
			J							
			K							
	HEC1008-R11□-T	110/25	G	60/350	950	0.56	650	Brown	Brown	Brown
			J							
			K							
	HEC1008-R12□-T	120/25	G	60/350	950	0.63	650	Brown	Red	Brown
			J							
			K							
	HEC1008-R15□-T	150/25	G	45/100	850	0.70	580	Brown	Green	Brown
			J							
			K							
	HEC1008-R18□-T	180/25	G	45/100	750	0.77	620	Brown	Gray	Brown
			J							
			K							
	HEC1008-R22□-T	220/25	G	45/100	700	0.84	500	Red	Red	Brown
			J							
			K							
	HEC1008-R24□-T	240/25	G	45/100	680	0.90	500	Red	Yellow	Brown
			J							
			K							

PRODUCT SPECIFICATION

SPEC. NO.

T-0620-001T

**4. Electrical Characteristics**

Customer Part Number	Our Product Part Number	Inductance (nH)/MHz	Inductance Tolerance	Q/MHz Min.	SRF(Min.) (MHz)	Rdc (Ω)Max.	Irms Max. (mA)	Color Coding		
								1st	2nd	3rd
	HEC1008-R25□-T	250/25	G	45/100	650	0.90	500	Red	Green	Brown
			J							
			K							
	HEC1008-R27□-T	270/25	G	45/100	600	0.91	500	Red	Violet	Brown
			J							
			K							
	HEC1008-R30□-T	300/25	G	45/100	590	1.00	500	Orange	Black	Brown
			J							
			K							
	HEC1008-R32□-T	320/25	G	45/100	580	1.03	500	Orange	Red	Brown
			J							
			K							
	HEC1008-R33□-T	330/25	G	45/100	570	1.05	450	Orange	Orange	Brown
			J							
			K							
	HEC1008-R35□-T	350/25	G	45/100	550	1.07	450	Orange	Green	Brown
			J							
			K							
	HEC1008-R36□-T	360/25	G	45/100	520	1.10	470	Orange	Blue	Brown
			J							
			K							
	HEC1008-R39□-T	390/25	G	45/100	500	1.12	470	Orange	White	Brown
			J							
			K							
	HEC1008-R43□-T	430/25	G	45/100	470	1.15	470	Yellow	Orange	Brown
			J							
			K							
	HEC1008-R47□-T	470/25	G	45/100	450	1.19	470	Yellow	Violet	Brown
			J							
			K							
	HEC1008-R56□-T	560/25	G	45/100	415	1.33	400	Green	Blue	Brown
			J							
			K							
	HEC1008-R62□-T	620/25	G	45/100	375	1.40	300	Blue	Red	Brown
			J							
			K							
	HEC1008-R68□-T	680/25	G	45/100	375	1.47	400	Blue	Gray	Brown
			J							
			K							
	HEC1008-R75□-T	750/25	G	45/100	360	1.54	360	Violet	Green	Brown
			J							
			K							
	HEC1008-R82□-T	820/25	G	45/100	350	1.61	400	Gray	Red	Brown
			J							
			K							
	HEC1008-R86□-T	860/25	G	45/100	330	1.65	400	Gray	Blue	Brown
			J							
			K							
	HEC1008-R91□-T	910/25	G	35/50	320	1.68	380	White	Brown	Brown
			J							
			K							

PRODUCT SPECIFICATION

SPEC. NO.

T-0620-001T

**4. Electrical Characteristics**

Customer Part Number	Our Product Part Number	Inductance (nH)/MHz	Inductance Tolerance	Q/MHz Min.	SRF(Min.) (MHz)	Rdc (Ω)Max.	Irms Max. (mA)	Color Coding		
								1st	2nd	3rd
	HEC1008-1R0□-T	1000/25	G	35/50	290	1.75	400	Brown	Black	Red
			J							
			K							
	HEC1008-1R2□-T	1200/7.9	G	35/50	250	2.00	310	Brown	Red	Red
			J							
			K							
	HEC1008-1R5□-T	1500/7.9	G	28/50	200	2.30	330	Brown	Green	Red
			J							
			K							
	HEC1008-1R8□-T	1800/7.9	G	28/50	160	2.60	300	Brown	Gray	Red
			J							
			K							
	HEC1008-2R2□-T	2200/7.9	G	28/50	160	2.80	280	Red	Red	Red
			J							
			K							
	HEC1008-2R7□-T	2700/7.9	G	22/25	135	3.20	290	Red	Violet	Red
			J							
			K							
	HEC1008-3R0□-T	3000/7.9	G	22/25	110	3.30	290	Orange	Black	Red
			J							
			K							
	HEC1008-3R3□-T	3300/7.9	G	22/25	110	3.40	290	Orange	Orange	Red
			J							
			K							
	HEC1008-3R9□-T	3900/7.9	G	20/25	100	3.60	260	Orange	White	Red
			J							
			K							
	HEC1008-4R7□-T	4700/7.9	G	20/25	90	4.00	260	Yellow	Violet	Red
			J							
			K							
	HEC1008-5R6□-T	5600/7.9	G	18/7.9	40	4.20	240	Green	Blue	Red
			J							
			K							
	HEC1008-6R8□-T	6800/7.9	G	18/7.9	40	4.90	200	Blue	Gray	Red
			J							
			K							
	HEC1008-8R2□-T	8200/7.9	G	18/7.9	25	6.00	170	Gray	Red	Red
			J							
			K							
	HEC1008-100□-T	10000/2.5	G	18/7.9	25	8.00	150	Brown	Black	Orange
			J							
			K							

PRODUCT SPECIFICATION

SPEC. NO.

T-0620-001T



- When ordering, please specify tolerance and packaging codes. Ex: HEC1008-R12J-T
Tolerance : G = $\pm 2\%$, J = $\pm 5\%$, K = $\pm 10\%$
Packaging : Clear tape and reel { standard }.
- L , Q 、 SRF : Agilent/HP E4991A+ Agilent/HP16197A
(The electrical specification test by the smallest gap position) or HP16193A
- Rdc : DIGITAL MILLIOHM METER Chroma 16502, or equivalent.
- Irms for a 15°C rise above 25°C ambient.
- Operating temperature range from -40°C to 125°C.

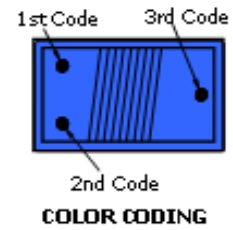

PRODUCT SPECIFICATION

SPEC. NO.

T-0620-001T

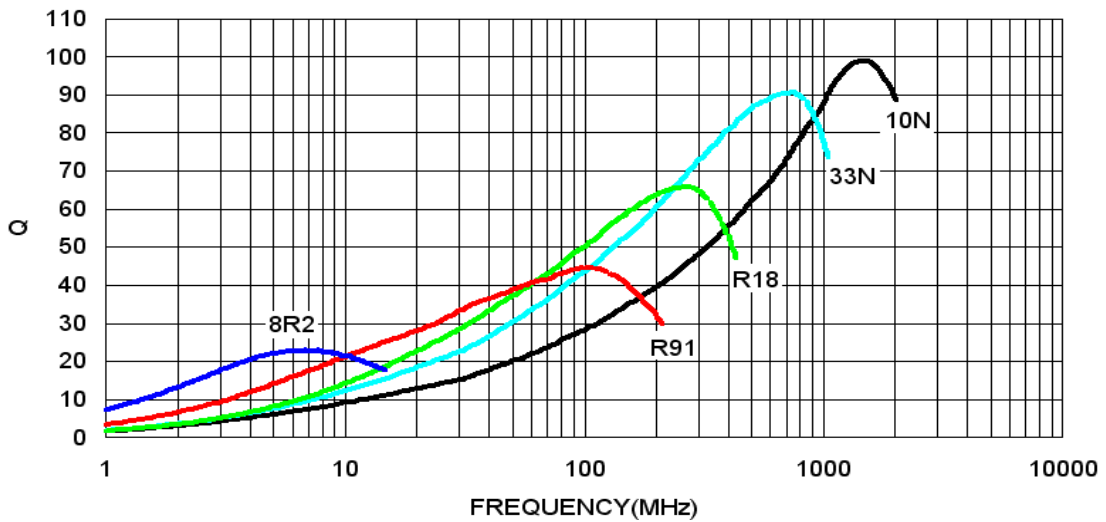
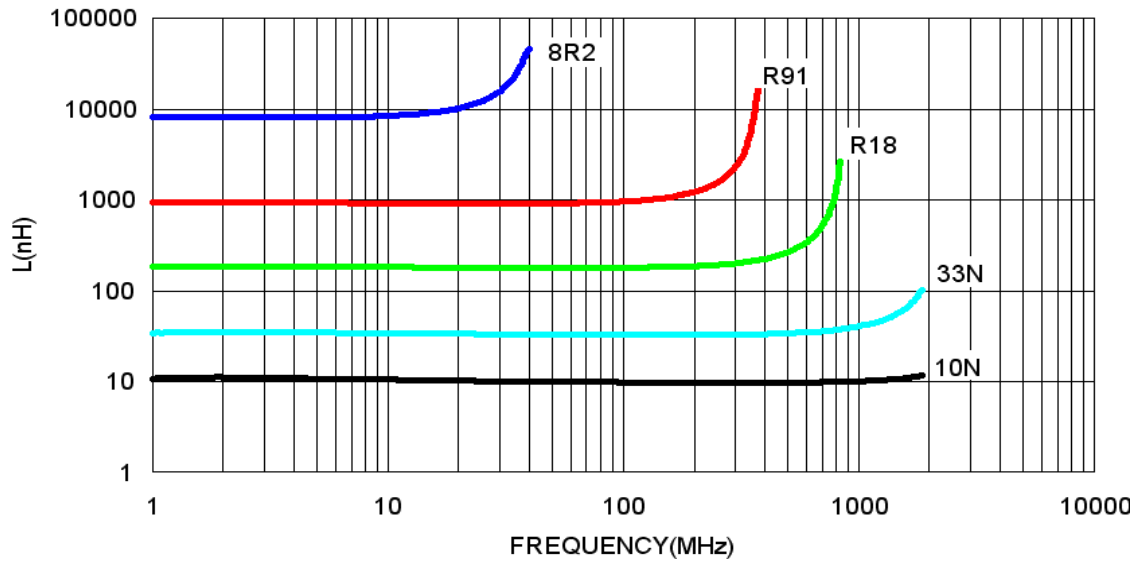

5. Material list

Item	Material
Core	Al ₂ O ₃ 96%
Wire	Copper wire
Epoxy	UV Epoxy

PRODUCT SPECIFICATION

SPEC. NO.

T-0620-001T

**6. Reliability Test**

Item	Specifications	Test conditions
Solderability	The metalized area must have 90% minimum solder coverage.	Dip pads in flux and dip in solder pot(96.5 Sn/3.5 Ag solder) at 255°C ±5°C.
Resistance to soldering heat	There must be no case deformation or change in dimensions. Inductance must not change more than the stated tolerance.	Inductors shall be reflowed onto a PC board using 96.5 Sn/3.5 Ag solder paste. Solder process shall be at a maximum temperature of 260°C. For 96.5 Sn/3.5 Ag solder paste:>217°C for 90 seconds
Vibration	There must be no case deformation or change in dimensions. Inductance must not change more than the stated tolerance.	Solder specimen inductor on the test printed circuit board. Apply vibrations in each of the x,y and z directions for 2 hours for a total of 6 hours. Frequency : 10~50 Hz Amplitude : 1.5mm
High temperature resistance	There must be no case deformation or change in dimensions. Inductance must not change more than the stated tolerance.	Inductors shall be subjected to temperature 125±2°C for 50±12 hours. Measure the test items after leaving the inductors at room temperature and humidity for 2 hours.
Static Humidity	Inductors must not have a shorted or openwinding.	Inductors shall be subjected to temperature 85±2°C and 90 to 95%RH. for ten 24-hours. Measure the test items after leaving the inductors at room temperature and humidity for 2 hours.
Component adhesion (push test)	Inductors shall be subjected to 1.8kg	Inductors shall be reflow soldered (255°C ±5°C for 10 seconds) to a tinned copper substrate. A force gauge shall be applied to the side of the component. The device must withstand the stated force without a failure of the termination.

PRODUCT SPECIFICATION

SPEC. NO.

T-0620-001T



Item	Specifications	Test conditions
Low temperature resistance	There must be no case deformation or change in dimensions. Inductance must not change more than the stated tolerance.	Inductors shall be subjected to temperature $-40\pm 2^{\circ}\text{C}$ for 48 ± 12 hours. Measure the test items after leaving the inductors at room temperature and humidity for 1 to 2 hours.
Resistance to solvent	There must be no case deformation, change in dimensions, or obliteration of marking.	Inductors must withstand 6 minutes of alcohol or water.
Thermal shock	There must be no case deformation or change in dimensions. Inductance must not change more than the stated tolerance.	Inductors shall be subjected to 10 cycles to the following temperature cycle: <div style="text-align: center;"> <p>The diagram illustrates a temperature cycle. The vertical axis shows temperature in degrees Celsius, with +125°C at the top and -40°C at the bottom. The horizontal axis represents time. A single cycle is shown as a trapezoidal wave. It starts at a baseline, drops to -40°C, stays there for 30 minutes, then ramps up to +125°C in 30 seconds, stays at +125°C for 30 minutes, and then ramps back down to the baseline. A double-headed arrow above the wave indicates the duration of '1 cycle'.</p> </div> Measure the test items after leaving the inductors at room temperature and humidity for 2 hours.

PRODUCT SPECIFICATION

SPEC. NO.

T-0620-001T



7. Packaging

The packaging must be done not to receive any damage during transporting and storing.

7-1 Tape dimensions

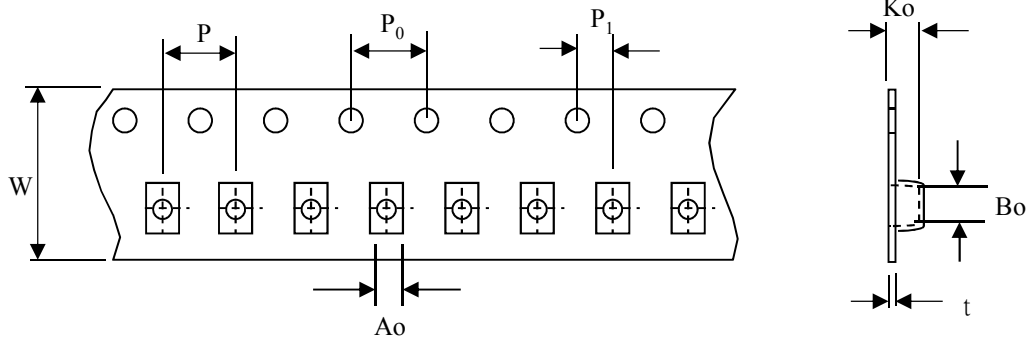

(Dimensions in mm; Tolerance : ±0.1)

Symbol	W	P	P ₀	P ₁	A ₀	Bo	Ko	t
Dimension	8	4	4	2	2.5	2.85	2	0.22

7-2 Reel dimensions

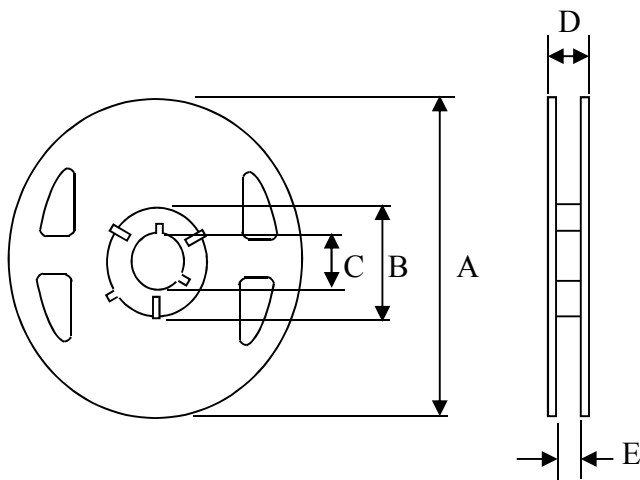

(Dimensions in mm)

Symbol	T
A	180
B	60
C	13
D	14.4
E	8.4

7-3 Tapping figure

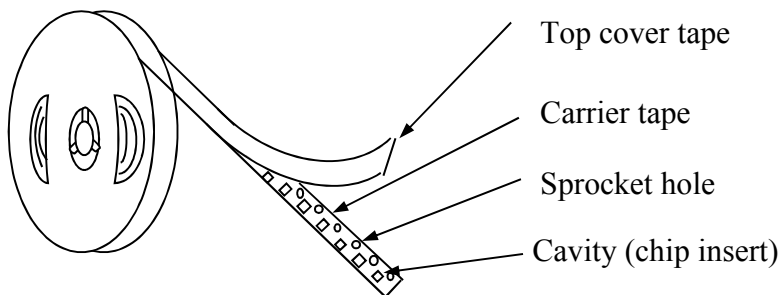

PRODUCT SPECIFICATION

SPEC. NO.

T-0620-001T



7-4 Packaging Form

There shall not continuation more than two vacancies of the product.

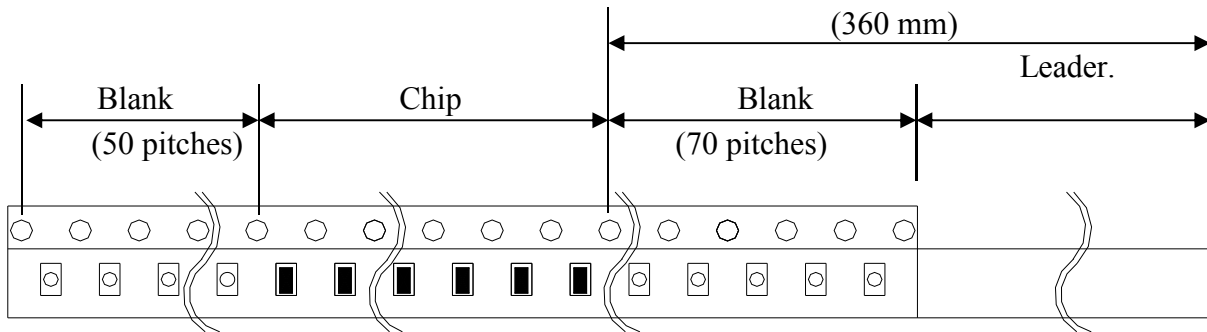

7-5 Cover Tape Peel Strength

The force for tearing off cover tape is 0.1~0.6(N) in the arrow direction at the following condition.

Temperature : 5 ~ 35°C

Humidity : 45 ~ 85%

Atmospheric pressure : 860 ~ 1060 hpa

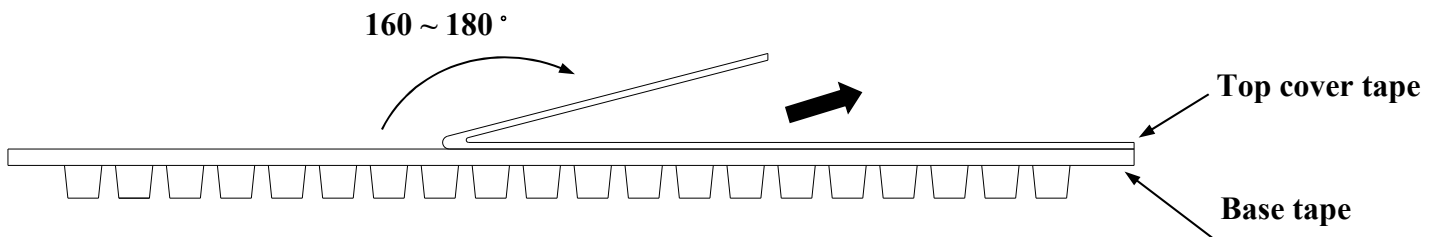

7-6 Packing Quantity

φ180 mm reel type : 2,000 pcs./reel

PRODUCT SPECIFICATION

SPEC. NO.

T-0620-001T



8. Recommended Soldering Conditions

(Please use this product by reflow soldering)

8-1 Recommended Footprint

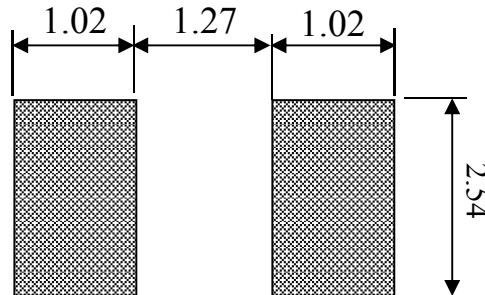

Unit: mm

8-2 Recommended Reflow Pattern

Reflow : until two times

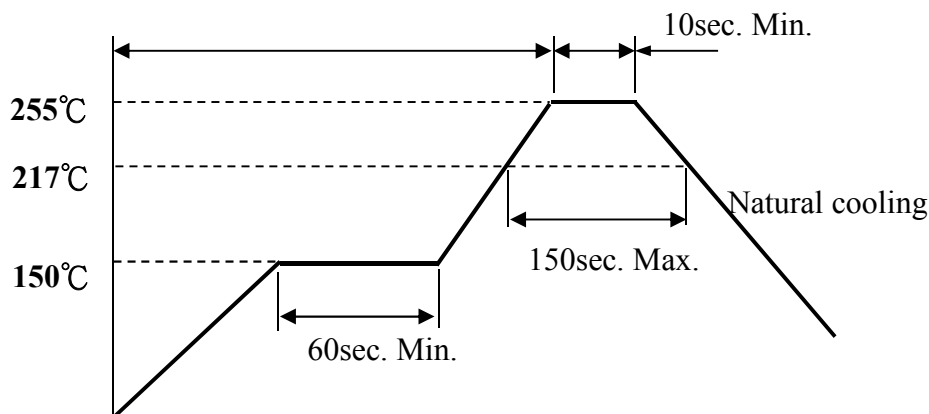

8-3 Iron Soldering

Use a solder iron of less than 30W when soldering, do not allow the soldering iron to directly touch the Ceramic body outside of terminal electrode.

5 seconds max. at 260°C.

9. Attention in Case of Using

In case of using product, please avoid following matters:

Splashing water or salt water

Dew condenses

Toxic gas (Hydrogen sulfide, Sulfurous acid, Chlorine, Ammonia)

Vibrations or shocks which exceed the specified condition

Please be careful for the stress to this product by board flexure or something after the mounting.

10. Others

10-1 Operating temperature range : Ceramic Series :-40~+125°C

10-2 Storage condition : Temperature 20°~25°C, Relative Humidity 40%~60%

10-3 Recommended wire wound inductors should be used within 6 months from the time of delivery.