

Standard SCRs, 30A

Main Features

Symbol	Value	Unit
$I_{T(RMS)}$	30	A
V_{DRM}/V_{RRM}	600 to 1200	V
I_{GT}	4 to 50	mA

DESCRIPTION

The 30PT series of silicon controlled rectifiers are high performance glass passivated technology, and are suitable for general purpose applications, where power dissipation are critical such as solid state relay, welding equipment and high power control.

Base on a clip assembly technology, they offer a superior performance in surge current capabilities.

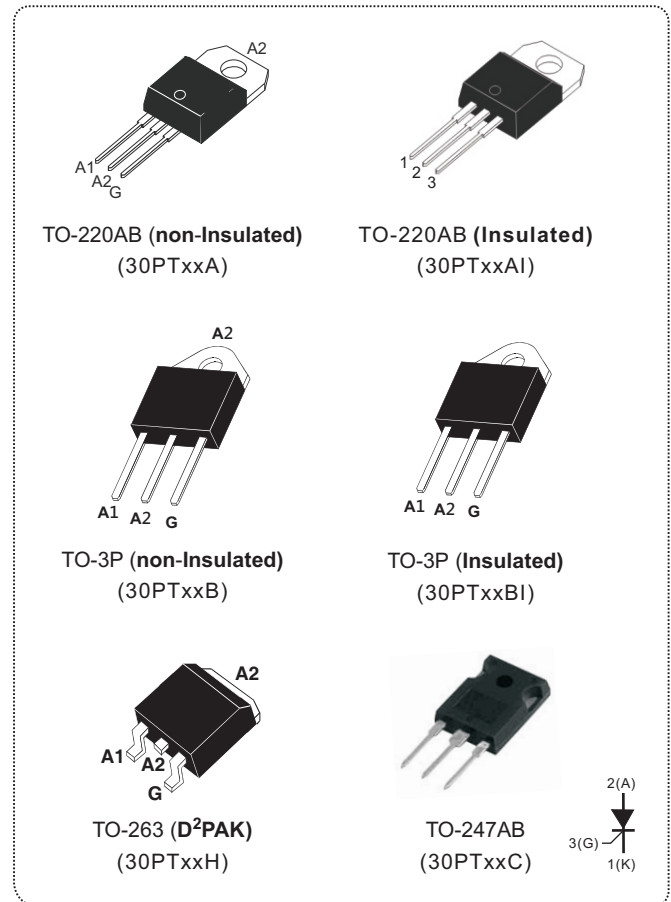

ABSOLUTE MAXIMUM RATINGS					
PARAMETER	SYMBOL	TEST CONDITIONS		VALUE	UNIT
RMS on-state current full sine wave (180° conduction angle)	$I_{T(RMS)}$	TO-3P/TO-247AB	$T_c=100^\circ\text{C}$	30	A
		TO-220AB/TO-263	$T_c=95^\circ\text{C}$		
		TO-220AB insulated/TO-3P insulated	$T_c=80^\circ\text{C}$		
Average on-state current (180° conduction angle)	$I_{T(AV)}$	TO-3P/TO-247AB	$T_c=100^\circ\text{C}$	19	A
		TO-220AB/TO-263	$T_c=95^\circ\text{C}$		
		TO-220AB insulated/TO-3P insulated	$T_c=80^\circ\text{C}$		
Non repetitive surge peak on-state current (full cycle, T_j initial = 25°C)	I_{TSM}	F = 50 Hz	t = 20 ms	400	A
		F = 60 Hz	t = 16.7 ms	420	
I^2t Value for fusing	I^2t	$t_p = 10$ ms		800	A^2s
Critical rate of rise of on-state current $I_G = 2 \times I_{GT}$, $t_r \leq 100\text{ns}$	di/dt	F = 60 Hz	$T_j = 125^\circ\text{C}$	50	$\text{A}/\mu\text{s}$
Peak gate current	I_{GM}	$T_p = 20$ μs	$T_j = 125^\circ\text{C}$	4	A
Maximum gate power	P_{GM}	$T_p = 20$ μs	$T_j = 125^\circ\text{C}$	10	W
Average gate power dissipation	$P_{G(AV)}$	$T_j = 125^\circ\text{C}$		1	W
Repetitive peak off-state voltage	V_{DRM}	$T_j = 125^\circ\text{C}$		600 to 1200	V
Repetitive peak reverse voltage	V_{RRM}				
Storage temperature range	T_{stg}			- 40 to + 150	°C
Operating junction temperature range	T_j			- 40 to + 125	
Maximum peak reverse gate voltage	V_{RGM}			5	V

ELECTRICAL SPECIFICATIONS (T _J = 25 °C unless otherwise specified)						
SYMBOL	TEST CONDITIONS			30PTxxxx	Unit	
I _{GT}	V _D = 12V, R _L = 33Ω			Min.	4	mA
				Max.	50	
V _{GT}				Max.	1.3	V
V _{GD}	V _D = V _{DRM} , R _L = 3.3KΩ, R _{GK} = 220Ω	T _J = 125°C		Min.	0.2	V
I _H	I _T = 500mA, Gate open			Max.	75	mA
I _L	I _G = 1.2×I _{GT}			Typ.	150	mA
dV/dt	V _D = 67% V _{DRM} , Gate open	V _{DRM} ≤ 800V	T _J = 125°C	Min.	500	V/μs
		V _{DRM} ≥ 1000V			250	
V _{TM}	I _T = 60A, t _p = 380μs		T _J = 25°C	Max.	1.6	V
I _{DRM} I _{RRM}	V _D =V _{DRM} , V _R =V _{RRM} R _{GK} = 220Ω		T _J = 25°C	Max.	5	μA
			T _J = 125°C	Max.	2	mA
V _{to}	Threshold Voltage		T _J = 125°C	Max.	1.27	V
R _d	Dynamic Resistance		T _J = 125°C	Max.	12	mΩ

THERMAL RESISTANCE						
SYMBOL	Parameter		VALUE	UNIT		
R _{th(j-c)}	Junction to case (DC)		D ² PAK/TO-220AB/TO-3P/TO-247AB	1.0	°C/W	
			TO-3P insulated	1.2		
			TO-220AB insulated	2.0		
R _{th(j-a)}	Junction to ambient		S = 1 cm ²	TO-263(D ² PAK)	45	°C/W
			TO-220AB/TO-220AB insulated	60		
			TO-3P/TO-247AB/TO-3P insulated	50		

S=Copper surface under tab

PRODUCT SELECTOR						
PART NUMBER	VOLTAGE (xx)				SENSITIVITY	PACKAGE
	600 V	800 V	1000 V	1200 V		
30PTxxA/30PTxxAI	V	V	V	V	50 mA	TO-220AB
30PTxxH	V	V	V	V	50 mA	D ² PAK
30PTxxB/30PTxxBI	V	V	V	V	50 mA	TO-3P
30PTxxC	V	V	V	V	50 mA	TO-247AB

ORDERING INFORMATION					
ORDERING TYPE	MARKING	PACKAGE	WEIGHT	BASE Q'TY	DELIVERY MODE
30PTxxA	30PTxxA	TO-220AB	2.0g	50	Tube
30PTxxAI	30PTxxAI	TO-220AB (insulated)	2.3g	50	Tube
30PTxxH	30PTxxH	TO-263(D ² PAK)	2.0g	50	Tube
30PTxxB	30PTxxB	TO-3P	4.3g	30	Tube
30PTxxBI	30PTxxBI	TO-3P insulated	4.8g	30	Tube
30PTxxC	30PTxxC	TO-247AB	5g	30	Tube

Note: xx = voltage

ORDERING INFORMATION SCHEME	
30 PT 06 AI	<p>Current 30 = 30A, $I_{T(RMS)}$</p> <p>SCR series</p> <p>Voltage Code 06 = 600V 08 = 800V 10 = 1000V 12 = 1200V 16 = 1600V</p> <p>Package type A = TO-220AB (non-insulated) AI = TO-220AB (insulated) B = TO-3P (non-insulated) BI = TO-3P (insulated) C = TO-247AB H = TO-263 (D²PAK)</p>

Fig.1 Maximum average power dissipation versus average on-state current.

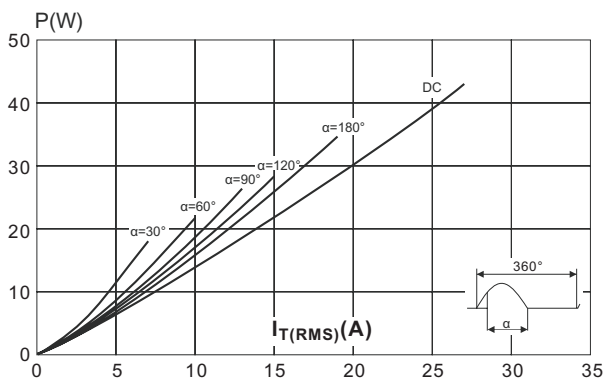

Fig.2 Correlation between maximum average power dissipation and maximum allowable temperature

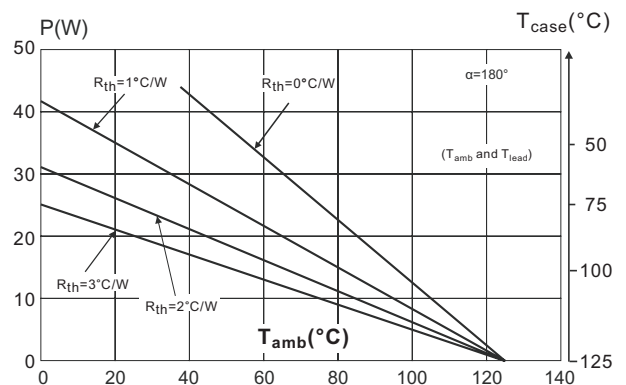

Fig.3 RMS on-state current versus case temperature.

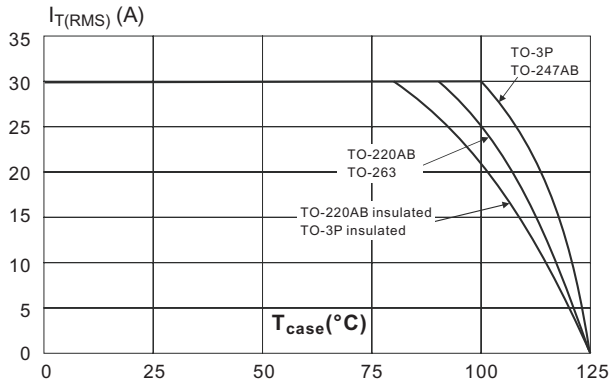

Fig.4 Relative variation of thermal impedance versus pulse duration.

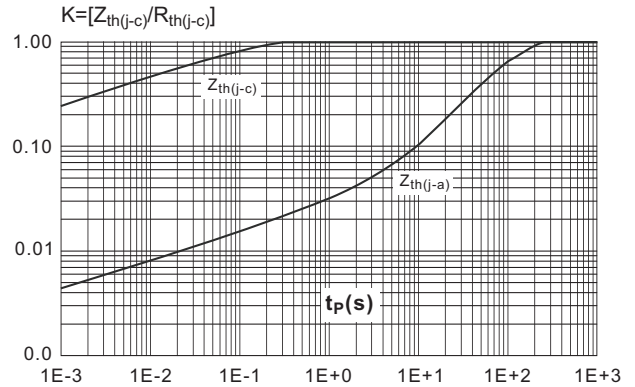

Fig.5 Relative variation of gate trigger current versus junction temperature.

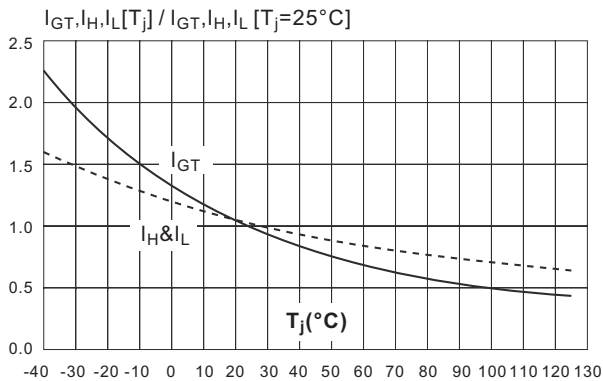

Fig.6 Surge peak on-state current versus number of cycles.

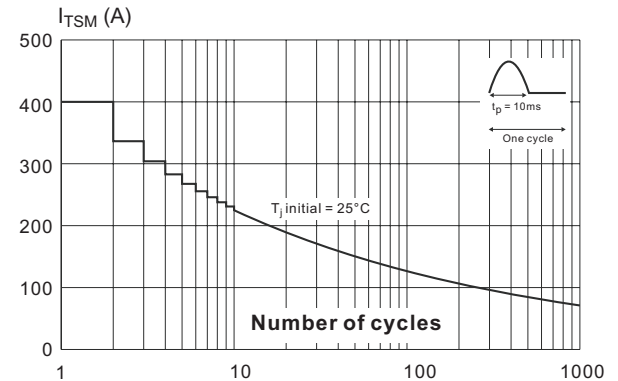

Fig.7 Non-repetitive surge peak on-state current and corresponding value of I^2t versus sinusoidal pulse width

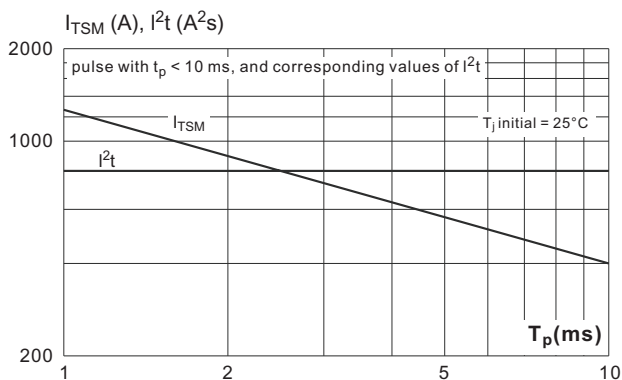
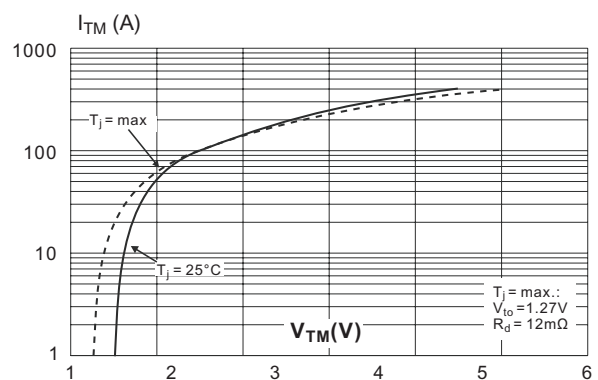
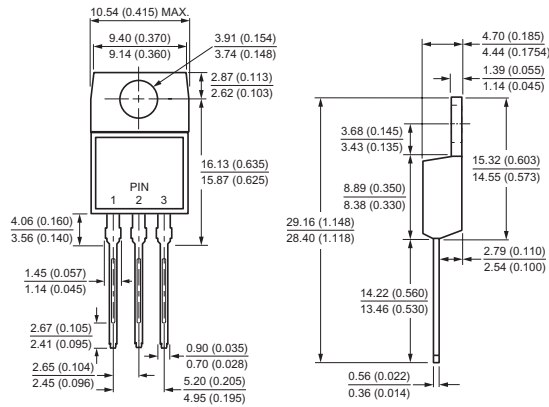

Fig.8 On-state characteristics (maximum values)



Case Style

TO-220AB



TO-3P

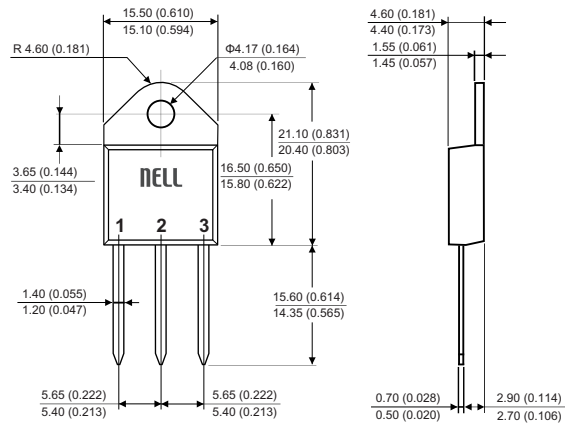

All dimensions in millimeters(inches)

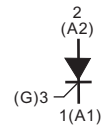

Case Style

TO-263(D²PAK)

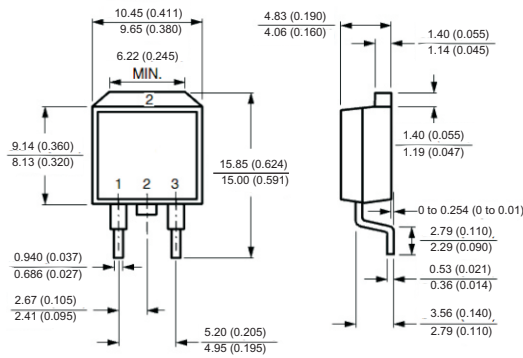

TO-247AB

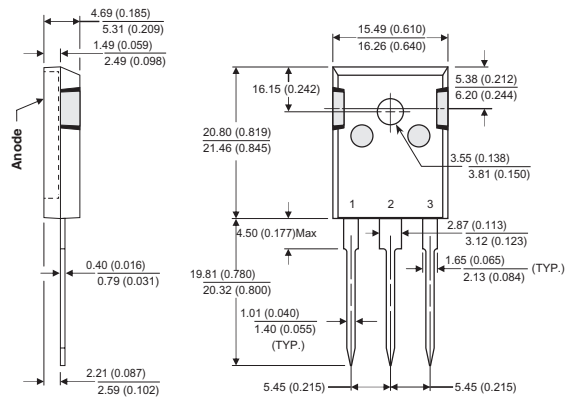

All dimensions in millimeters(inches)

