

DELPHI SERIES

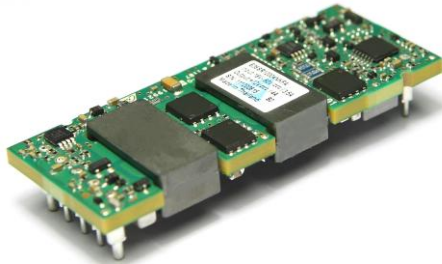

FEATURES

- ◆ High efficiency: 90.5% @ 12V/4A
- ◆ Size:
58.4x22.8x8.73mm (2.30"x0.90"x0.34")
- ◆ Standard footprint
- ◆ Industry standard pin out
- ◆ Fixed frequency operation
- ◆ Input UVLO, Output OCP, OVP, OTP
- ◆ 1500V isolation and basic insulation
- ◆ ISO 9001, TL 9000, ISO 14001, QS9000, OHSAS18001 certified manufacturing facility
- ◆ UL/cUL 60950-1 (US & Canada) recognized

Delphi E36SR Series DC/DC Power Modules: 18~60 in, 12V/4A out, 48W

The Delphi E36SR series, Eighth brick sized, 24V/48V input, single output, isolated DC/DC converter, is the latest offering from a world leader in power system technology and manufacturing — Delta Electronics, Inc. The E36SR12V provides up to 48 watts of power in an industry standard footprint and pinout. With creative design technology and optimization of component placement, these converters possess outstanding electrical and thermal performances, as well as extremely high reliability under highly stressful operating conditions. All models are fully protected from abnormal input/output voltage, current, and temperature conditions. The Delphi Series converters meet all safety requirements with basic insulation.

OPTIONS

- ◆ Positive On/Off logic

APPLICATIONS

- ◆ Telecom/Datacom
- ◆ Wireless Networks
- ◆ Optical Network Equipment
- ◆ Server and Data Storage
- ◆ Industrial/Test Equipment

TECHNICAL SPECIFICATIONS

(T_A=25°C, airflow rate=300 LFM, V_{in}=24/48Vdc, nominal V_{out} unless otherwise noted.)

PARAMETER	NOTES and CONDITIONS	E36SR12004			
		Min.	Typ.	Max.	Units
ABSOLUTE MAXIMUM RATINGS					
Input Voltage					
Continuous				60	Vdc
Transient (100ms)	100ms			100	Vdc
Operating Ambient Temperature		-40		85	°C
Storage Temperature		-55		125	°C
Input/Output Isolation Voltage				1500	Vdc
INPUT CHARACTERISTICS					
Operating Input Voltage		18		60	Vdc
Input Under-Voltage Lockout					
Turn-On Voltage Threshold		16	17	18	Vdc
Turn-Off Voltage Threshold		14	15	16	Vdc
Lockout Hysteresis Voltage		1	2	3	Vdc
Maximum Input Current	100% Load, 18Vin			3.5	A
No-Load Input Current		30	60	120	mA
Off Converter Input Current		3		10	mA
Inrush Current (I ² t)				1	A ² s
Input Reflected-Ripple Current	P-P thru 12µH inductor, 5Hz to 20MHz		20		mA
Input Voltage Ripple Rejection	120 Hz		50		dB
OUTPUT CHARACTERISTICS					
Output Voltage Set Point	V _{in} =48V, I _o =I _{o,max} , T _c =25°C	11.820	12.000	12.180	Vdc
Output Voltage Regulation					
Over Load	I _o =I _{o,min} to I _{o,max}		±24	±48	mV
Over Line	V _{in} =18V to 60V		±24	±48	mV
Over Temperature	T _c =-40°C to 85°C			±180	mV
Total Output Voltage Range	Over sample load, line and temperature	11.8		12.2	Vdc
Output Voltage Ripple and Noise					
Peak-to-Peak	5Hz to 20MHz bandwidth				
RMS	Full Load, 1µF ceramic, 10µF tantalum		50	100	mV
Operating Output Current Range	Full Load, 1µF ceramic, 10µF tantalum	0.4		4	A
Output Over Current Protection		4.4		5.6	A
DYNAMIC CHARACTERISTICS					
Output Voltage Current Transient					
Positive Step Change in Output Current	48V, 10µF Tan & 1µF Ceramic load cap, 0.1A/µs				
Negative Step Change in Output Current	50% I _{o,max} to 75% I _{o,max}		200	400	mV
Settling Time (within 1% V _{out} nominal)	75% I _{o,max} to 50% I _{o,max}		200	400	mV
Turn-On Transient			100		us
Start-Up Time, From On/Off Control			15	25	ms
Start-Up Time, From Input			15	25	ms
Maximum Output Capacitance	Full load; 5% overshoot of V _{out} at startup			2000	µF
EFFICIENCY					
I _o from 2.8A to 4A	V _{in} From 18v to 55v	89.5			%
ISOLATION CHARACTERISTICS					
Input to Output				1500	Vdc
Isolation Resistance			10		MΩ
Isolation Capacitance			1000		pF
FEATURE CHARACTERISTICS					
Switching Frequency					
ON/OFF Control, Negative Remote On/Off logic			300		kHz
Logic Low (Module On)	V _{on/off} at I _{on/off} =1.0mA	0		0.8	V
Logic High (Module Off)	V _{on/off} at I _{on/off} =0.0 µA	3		12	V
ON/OFF Control, Positive Remote On/Off logic					
Logic Low (Module Off)	V _{on/off} at I _{on/off} =1.0mA	0		0.8	V
Logic High (Module On)	V _{on/off} at I _{on/off} =0.0 µA	3.5		12	V
ON/OFF Current (for both remote on/off logic)	I _{on/off} at V _{on/off} =0.0V			1	mA
Leakage Current (for both remote on/off logic)	Logic High, V _{on/off} =12V			50	µA
Output Over-Voltage Protection	Over full temp range;	13.2		16.8	V
GENERAL SPECIFICATIONS					
MTBF	I _o =100% of I _{o,max} ; T _a =25°C, airflow rate=200FLM		6.48		M hours
Weight			22.9		Grams
Over-Temperature Shutdown (Hot Spot)	Refer to Figure 21 for Hot spot location (48Vin, 80%I _o , 200LFM, Airflow from Vin- to Vin+)		124		°C
Over-Temperature Shutdown (NTC Resistor)	Refer to Figure 21 for NTC resistor location		120		°C

Note: Please attach thermocouple on NTC resistor to test OTP function, the hot spot's temperature is just for reference.



ELECTRICAL CHARACTERISTICS CURVES

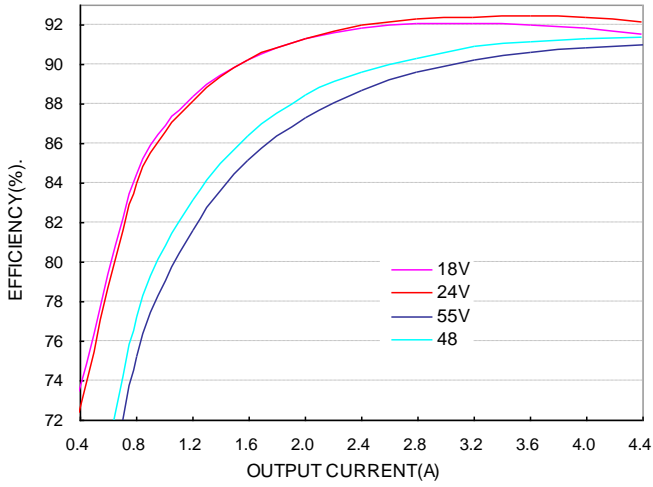

Figure 1: Efficiency vs. load current for minimum, nominal, and maximum input voltage at 25°C, 300LFM airflow.

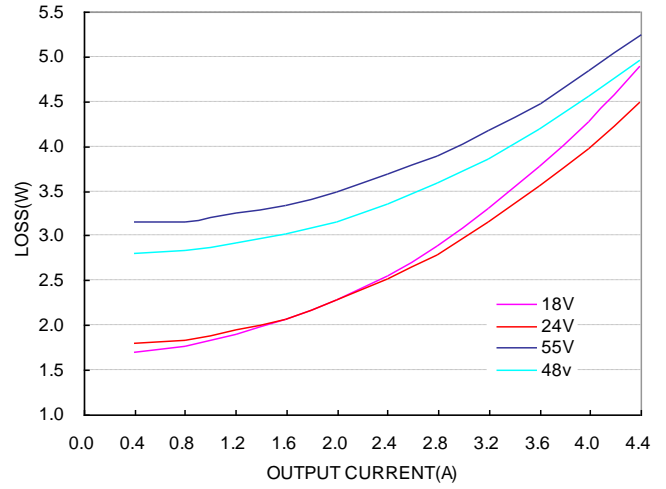

Figure 2: Power dissipation vs. load current for minimum, nominal, and maximum input voltage at 25°C, 300LFM airflow.

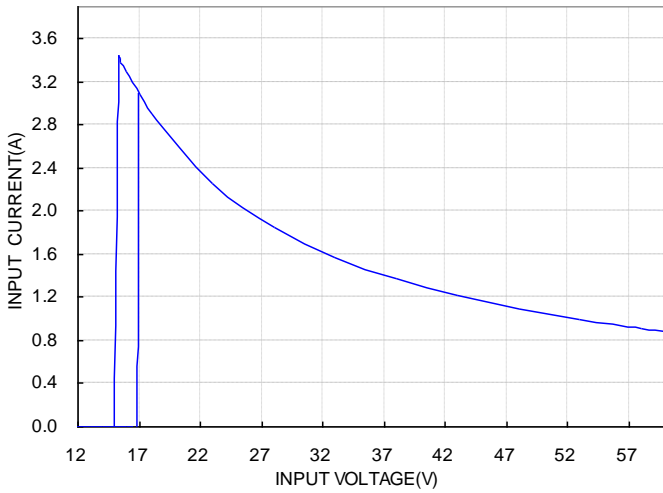

Figure 3: Typical full load input characteristics at 25°C



ELECTRICAL CHARACTERISTICS CURVES

For Input Voltage On/Off

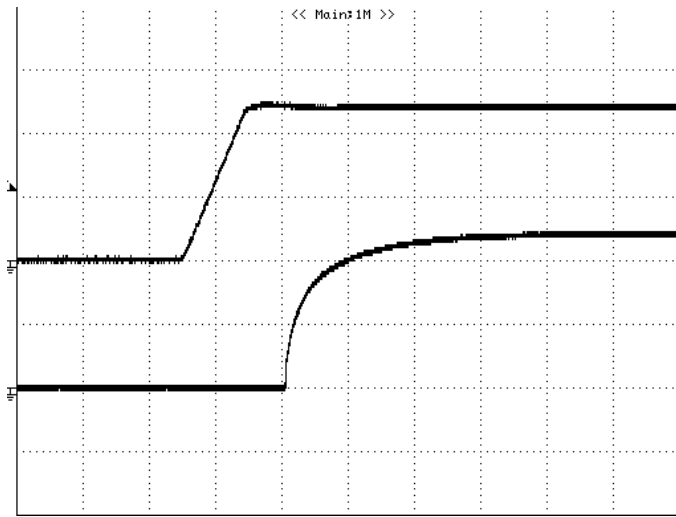

Figure 4: Turn-on transient at full rated load current (5ms/div). Vin=48V. Top Trace: Input Voltage, 20V/div; Bottom Trace: Vout, 5V/div

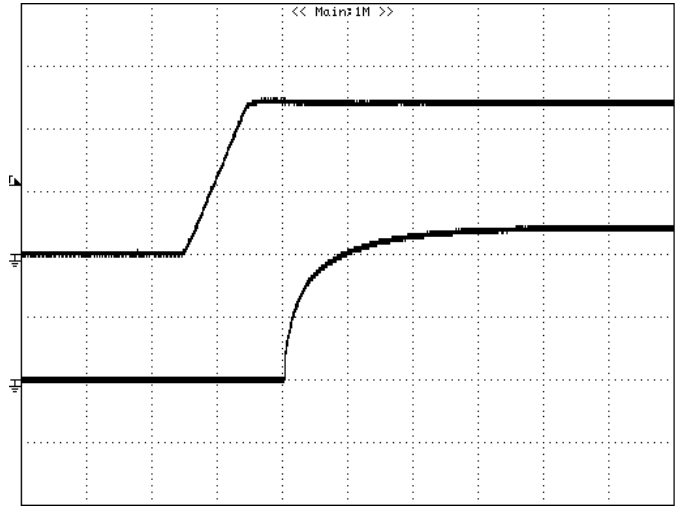

Figure 5: Turn-on transient at min load current (5ms/div). Vin=48V. Top Trace: Input Voltage, 20V/div; Bottom Trace: Vout, 5V/div

For negative On/Off Logic

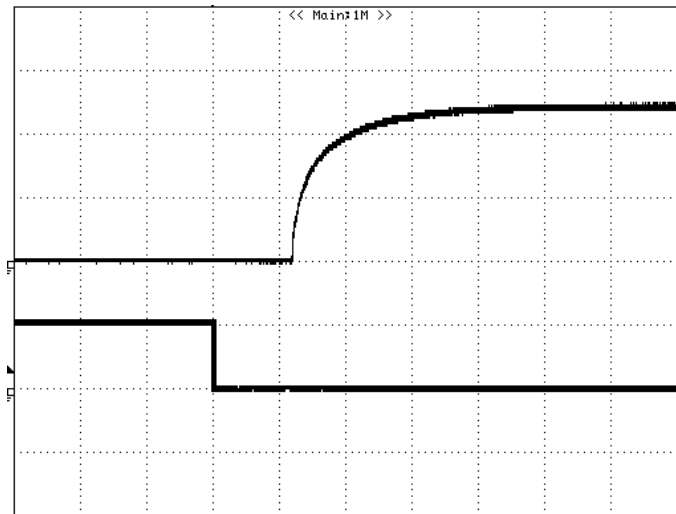

Figure 6: Turn-on transient at full rated load current (5ms/div) for negative on/off mode. Vin=48V. Top Trace: Vout, 5V/div; Bottom Trace: ON/OFF input, 5V/div

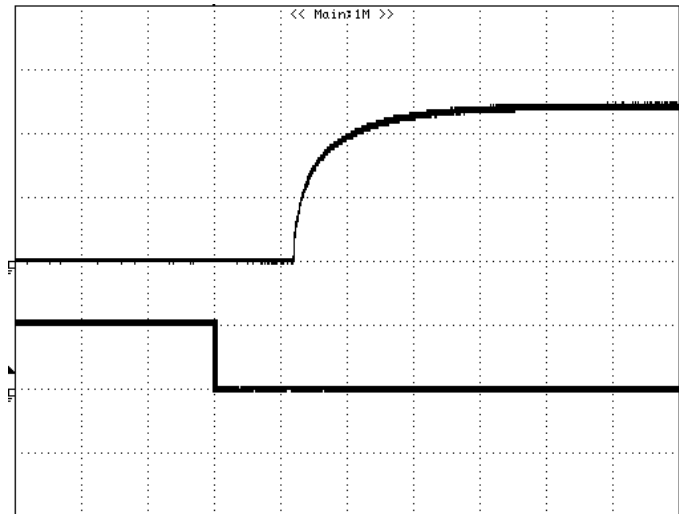

Figure 7: Turn-on transient at min load current (5ms/div) for negative on/off mode. Vin=48V. Top Trace: Vout, 5V/div; Bottom Trace: ON/OFF input, 5V/div

ELECTRICAL CHARACTERISTICS CURVES

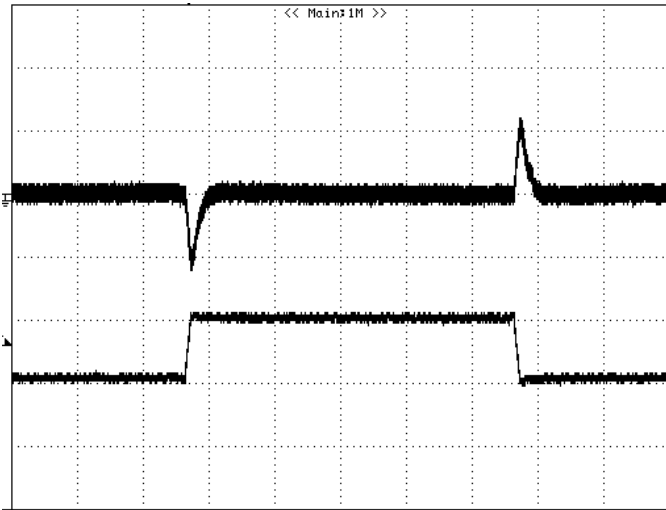

Figure 8: Output voltage response to step-change in load current (75%-50%-75% of $I_{o, \max}$; $di/dt = 0.01A/\mu s$). Load cap: $10\mu F$ tantalum capacitor and $1\mu F$ ceramic capacitor. Top Trace: V_{out} (0.1V/div, 1ms/div), Bottom Trace: I_{out} (1A/div). Scope measurement should be made using a BNC cable (length shorter than 20 inches). Position the load between 51 mm to 76 mm (2 inches to 3 inches) from the module

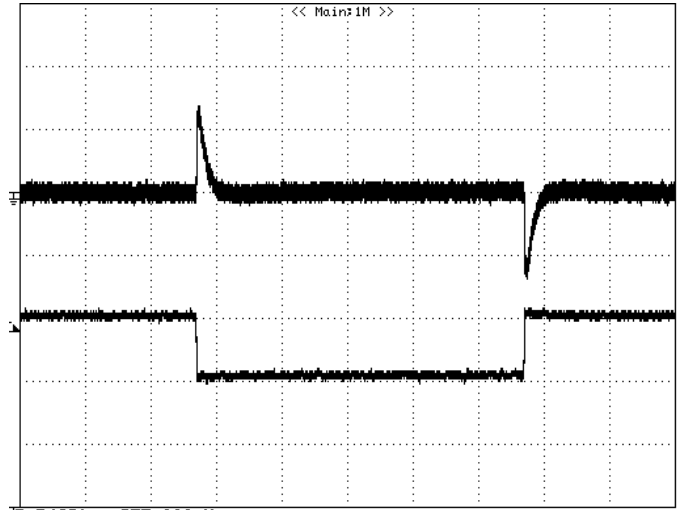

Figure 9: Output voltage response to step-change in load current (75%-50%-75% of $I_{o, \max}$; $di/dt = 2.5A/\mu s$). Load cap: $47\mu F$, $35m\Omega$ ESR solid electrolytic capacitor and $1\mu F$ ceramic capacitor. Top Trace: V_{out} (0.1 V/div, 1ms/div), Bottom Trace: I_{out} (1A/div). Scope measurement should be made using a BNC cable (length shorter than 20 inches). Position the load between 51 mm to 76 mm (2 inches to 3 inches) from the module

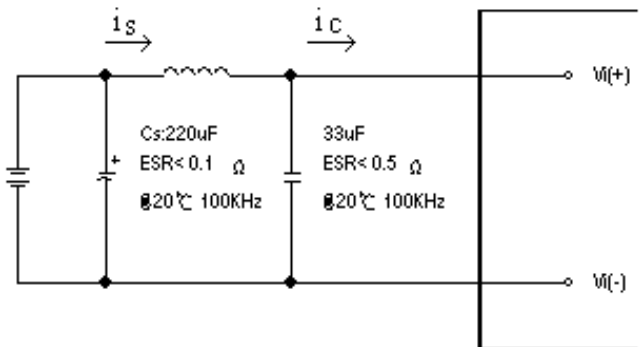

Figure 10: Test set-up diagram showing measurement points for Input Terminal Ripple Current and Input Reflected Ripple Current.

Note: Measured input reflected-ripple current with a simulated source Inductance (L_{TEST}) of $12\mu H$. Capacitor C_s offset possible battery impedance. Measured current as shown below

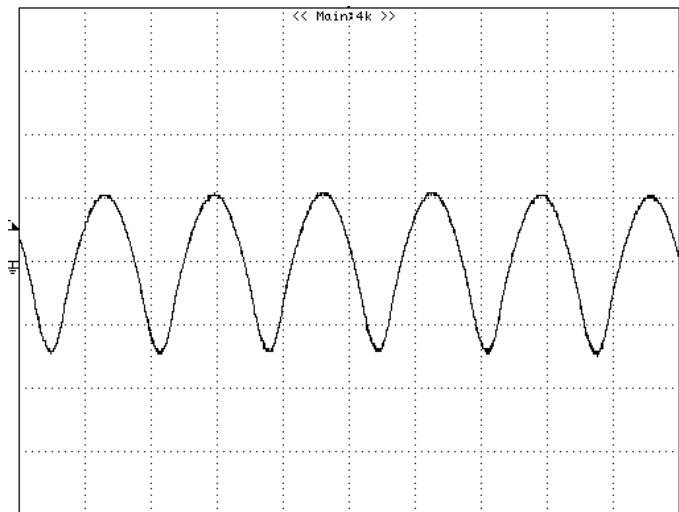

Figure 11: Input Terminal Ripple Current, i_c , at full rated output current and nominal input voltage with $12\mu H$ source impedance and $33\mu F$ electrolytic capacitor (200mA/div, 2us/div)

ELECTRICAL CHARACTERISTICS CURVES

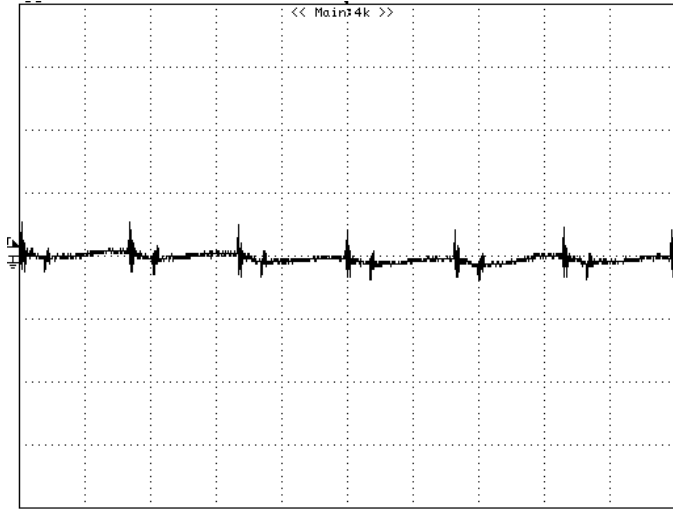

Figure 12: Input reflected ripple current, i_s , through a $12\mu\text{H}$ source inductor at nominal input voltage and rated load current (100 mA/div , $2\mu\text{s/div}$)

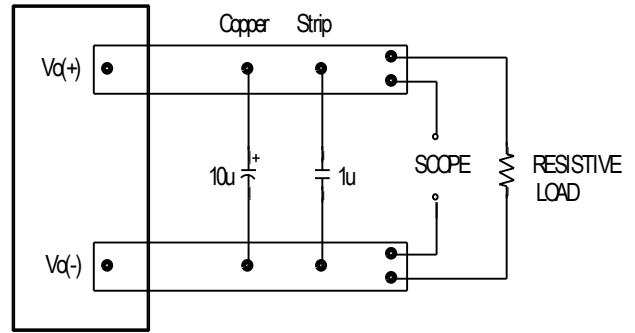

Figure 13: Output voltage noise and ripple measurement test setup

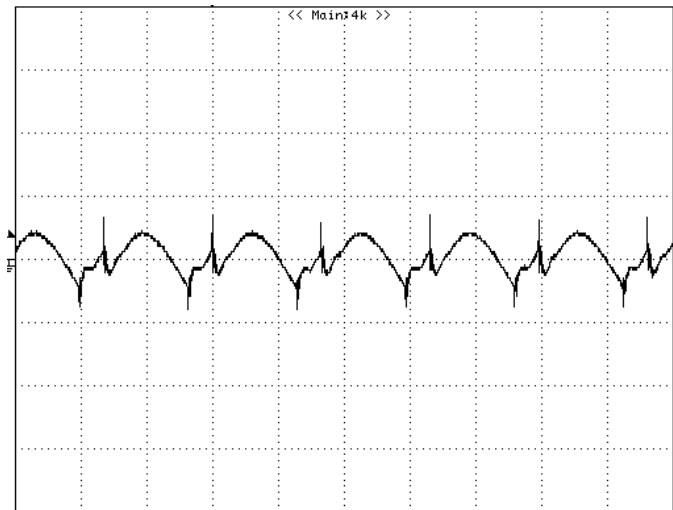

Figure 14: Output voltage ripple at nominal input voltage and rated load current ($I_o=4\text{A}$) (20mV/div , $2\mu\text{s/div}$)
 Load capacitance: $1\mu\text{F}$ ceramic capacitor and $10\mu\text{F}$ tantalum capacitor. Bandwidth: 20 MHz . Scope measurements should be made using a BNC cable (length shorter than 20 inches). Position the load between 51 mm to 76 mm (2 inches to 3 inches) from the module.

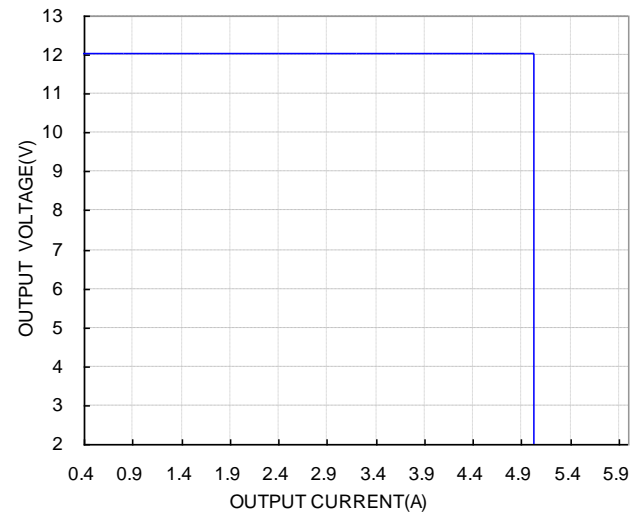

Figure 15: Output voltage vs. load current showing typical current limit curves and converter shutdown points

DESIGN CONSIDERATIONS

Input Source Impedance

The impedance of the input source connecting to the DC/DC power modules will interact with the modules and affect the stability. A low ac-impedance input source is recommended. If the source inductance is more than a few μH , we advise adding a 10 to 100 μF electrolytic capacitor (ESR $< 0.7 \Omega$ at 100 kHz) mounted close to the input of the module to improve the stability.

Layout and EMC Considerations

Delta's DC/DC power modules are designed to operate in a wide variety of systems and applications. For design assistance with EMC compliance and related PWB layout issues, please contact Delta's technical support team. An external input filter module is available for easier EMC compliance design. Application notes to assist designers in addressing these issues are pending to release.

Safety Considerations

The power module must be installed in compliance with the spacing and separation requirements of the end-user's safety agency standard, i.e., UL60950-1, CSA C22.2 NO. 60950-1 2nd and IEC 60950-1 2nd : 2005 and EN 60950-1 2nd: 2006+A11+A1: 2010, if the system in which the power module is to be used must meet safety agency requirements.

Basic insulation based on 60 Vdc input is provided between the input and output of the module for the purpose of applying insulation requirements when the input to this DC-to-DC converter is identified as TNV-2 or SELV. An additional evaluation is needed if the source is other than TNV-2 or SELV.

When the input source is SELV circuit, the power module meets SELV (safety extra-low voltage) requirements. If the input source is a hazardous voltage which is greater than 60 Vdc and less than or equal to 60 Vdc, for the module's output to meet SELV requirements, all of the following must be met:

- The input source must be insulated from the ac mains by reinforced or double insulation.
- The input terminals of the module are not operator accessible.
- A SELV reliability test is conducted on the system where the module is used, in combination with the module, to ensure that under a single fault, hazardous voltage does not appear at the module's output.

When installed into a Class II equipment (without grounding), spacing consideration should be given to the end-use installation, as the spacing between the module and mounting surface have not been evaluated.

The power module has extra-low voltage (SELV) outputs when all inputs are SELV.

This power module is not internally fused. To achieve optimum safety and system protection, an input line fuse is highly recommended. The safety agencies require a normal-blow fuse with 10A maximum rating to be installed in the ungrounded lead. A lower rated fuse can be used based on the maximum inrush transient energy and maximum input current.

Soldering and Cleaning Considerations

Post solder cleaning is usually the final board assembly process before the board or system undergoes electrical testing. Inadequate cleaning and/or drying may lower the reliability of a power module and severely affect the finished circuit board assembly test. Adequate cleaning and/or drying are especially important for un-encapsulated and/or open frame type power modules. For assistance on appropriate soldering and cleaning procedures, please contact Delta's technical support team.

FEATURES DESCRIPTIONS

Over-Current Protection

The modules include an internal output over-current protection circuit, which will endure current limiting for an unlimited duration during output overload. If the output current exceeds the OCP set point, the modules will automatically shut down (hiccup mode).

The modules will try to restart after shutdown. If the overload condition still exists, the module will shut down again. This restart trial will continue until the overload condition is corrected.

Over-Voltage Protection

The modules include an internal output over-voltage protection circuit, which monitors the voltage on the output terminals. If this voltage exceeds the over-voltage set point, the module will shut down (Hiccup mode). The modules will try to restart after shutdown. If the fault condition still exists, the module will shut down again. This restart trial will continue until the fault condition is corrected.

Over-Temperature Protection

The over-temperature protection consists of circuitry that provides protection from thermal damage. If the temperature exceeds the over-temperature threshold the module will shut down.

The module will try to restart after shutdown. If the over-temperature condition still exists during restart, the module will shut down again. This restart trial will continue until the temperature is within specification.

Remote On/Off

The remote on/off feature on the module can be either negative or positive logic. Negative logic turns the module on during a logic low and off during logic high. Positive logic turns the modules on during logic high and off during logic low.

Remote on/off can be controlled by an external switch between the on/off terminal and the Vi(-) terminal. The switch can be an open collector or open drain.

For negative logic if the remote on/off feature is not used, please short the on/off pin to Vi(-). For positive logic if the remote on/off feature is not used, please leave the on/off pin floating.

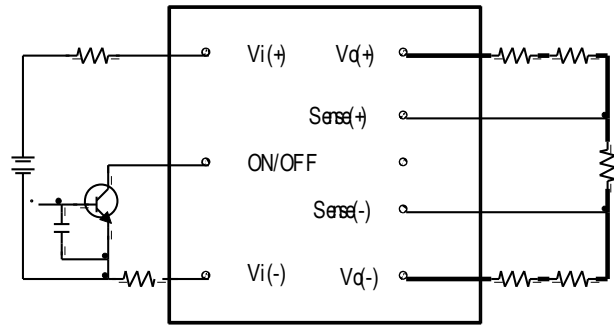

Figure 16: Remote on/off implementation

Remote Sense

Remote sense compensates for voltage drops on the output by sensing the actual output voltage at the point of load. The voltage between the remote sense pins and the output terminals must not exceed the output voltage sense range given here:

$$[Vo(+) - Vo(-)] - [SENSE(+) - SENSE(-)] \leq 10\% \times Vout$$

This limit includes any increase in voltage due to remote sense compensation

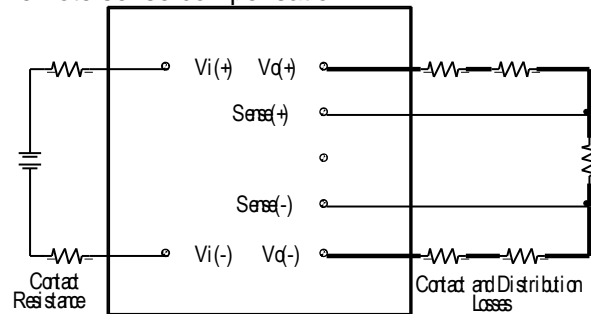

Figure 17: Effective circuit configuration for remote sense operation

If the remote sense feature is not used to regulate the output at the point of load, please connect SENSE(+) to Vo(+) and SENSE(-) to Vo(-) at the module.

The output voltage can be increased by the remote sense; When using the remote sense the output voltage of the module is usually increased, which increases the power output of the module with the same output current.

Care should be taken to ensure that the maximum output power does not exceed the maximum rated power.

Output Voltage Adjustment (TRIM)

To increase or decrease the output voltage set point, connect an external resistor between the TRIM pin and either the SENSE(+) or SENSE(-). The TRIM pin should be left open if this feature is not used.

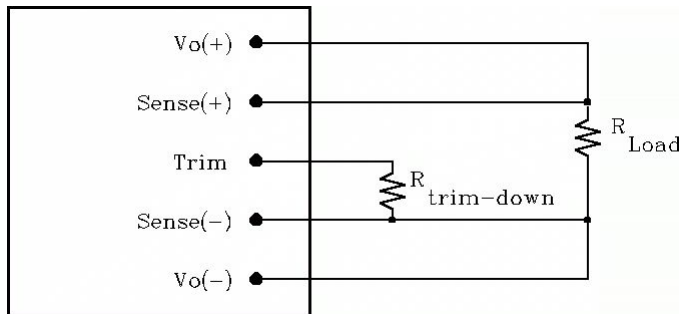

Figure 18: Circuit configuration for trim-down (decrease output voltage)

If the external resistor is connected between the TRIM and SENSE (-) pins, the output voltage set point decreases (Fig. 18). The external resistor value required to obtain a percentage of output voltage change $\Delta\%$ is defined as:

$$R_{trim-down} = \frac{510}{\Delta} - 10(K\Omega)$$

Ex. When Trim-down -20% ($12V \times 0.8 = 9.6V$)

$$R_{trim-down} = \frac{510}{20} - 10 = 15.5(K\Omega)$$

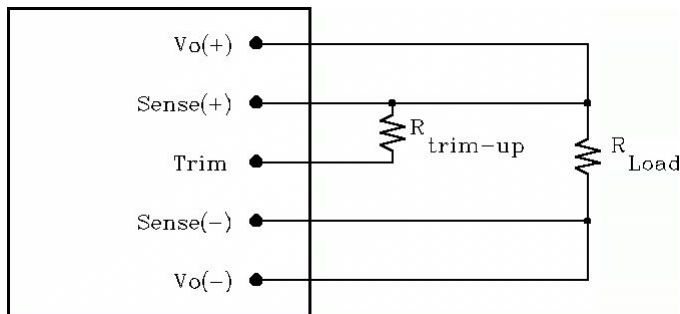

Figure 19: Circuit configuration for trim-up (increase output voltage)

If the external resistor is connected between the TRIM and SENSE (+) the output voltage set point increases (Fig. 19). The external resistor value required to obtain a percentage output voltage change $\Delta\%$ is defined as:

$$R_{trim-up} = \frac{5.1V_o(100+\Delta)}{1.225\Delta} - \frac{510}{\Delta} - 10(K\Omega)$$

Ex. When Trim-up +10% ($12V \times 1.1 = 13.2V$)

$$R_{trim-up} = \frac{5.1 \times 12 \times (100+10)}{1.225 \times 10} - \frac{510}{10} - 10 = 488.55(K\Omega)$$

The output voltage can be increased by both the remote sense and the trim, however the maximum increase is the larger of either the remote sense or the trim, not the sum of both.

When using remote sense and trim, the output voltage of the module is usually increased, which increases the power output of the module with the same output current.

Care should be taken to ensure that the maximum output power of the module remains at or below the maximum rated power.

THERMAL CONSIDERATIONS

Thermal management is an important part of the system design. To ensure proper, reliable operation, sufficient cooling of the power module is needed over the entire temperature range of the module. Convection cooling is usually the dominant mode of heat transfer.

Hence, the choice of equipment to characterize the thermal performance of the power module is a wind tunnel.

Thermal Testing Setup

Delta's DC/DC power modules are characterized in heated vertical wind tunnels that simulate the thermal environments encountered in most electronics equipment. This type of equipment commonly uses vertically mounted circuit cards in cabinet racks in which the power modules are mounted.

The following figure shows the wind tunnel characterization setup. The power module is mounted on a test PWB and is vertically positioned within the wind tunnel. The space between the neighboring PWB and the top of the power module is constantly kept at 6.35mm (0.25").

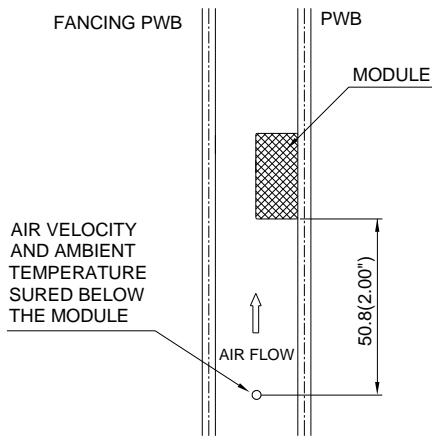

Note: Wind Tunnel Test Setup Figure Dimensions are in millimeters and (Inches)

Figure 20: Wind tunnel test setup

Thermal Derating

Heat can be removed by increasing airflow over the module. To enhance system reliability, the power module should always be operated below the maximum operating temperature. If the temperature exceeds the maximum module temperature, reliability of the unit may be affected.

THERMAL CURVES

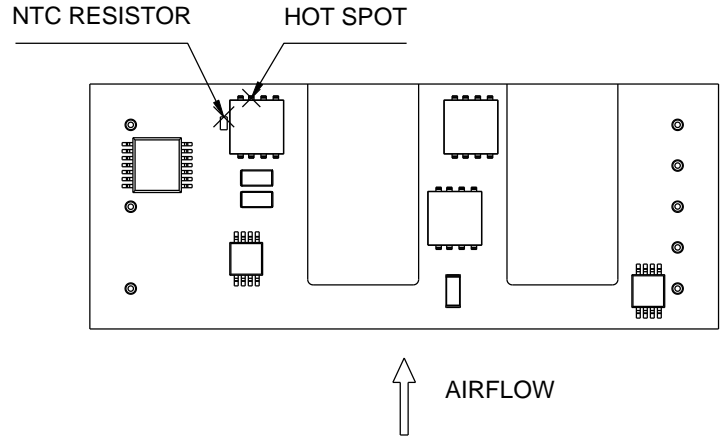

Figure 21: * Hot spot & NTC resistor temperature measured points.

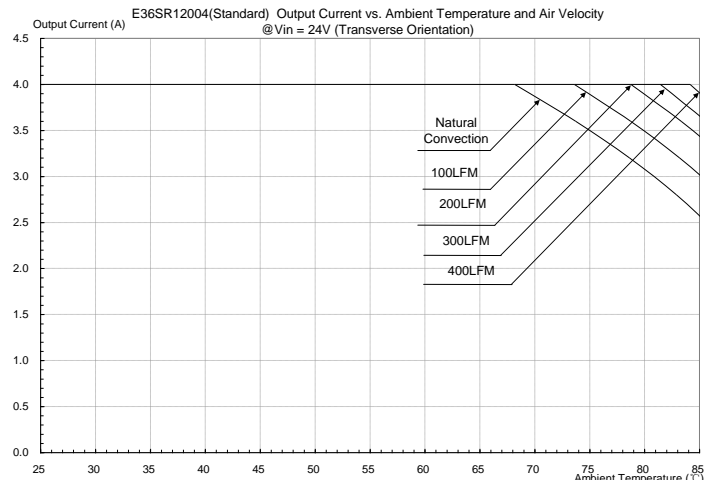

Figure 22: Output current vs. ambient temperature and air velocity @ Vin=24V (Transverse orientation, airflow from Vin- to Vin+)

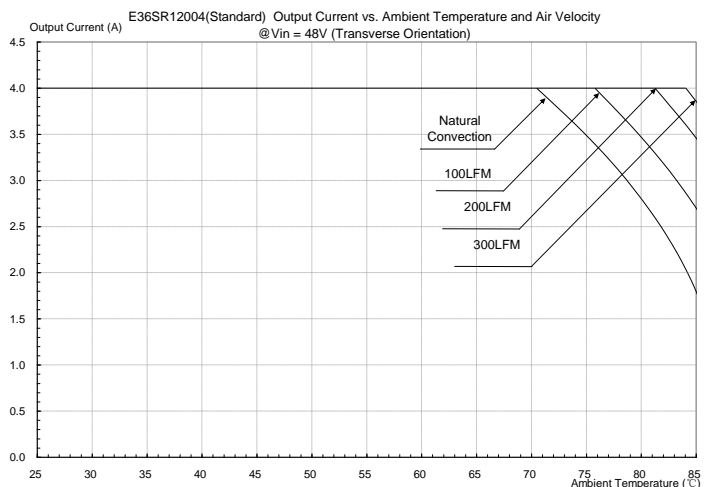
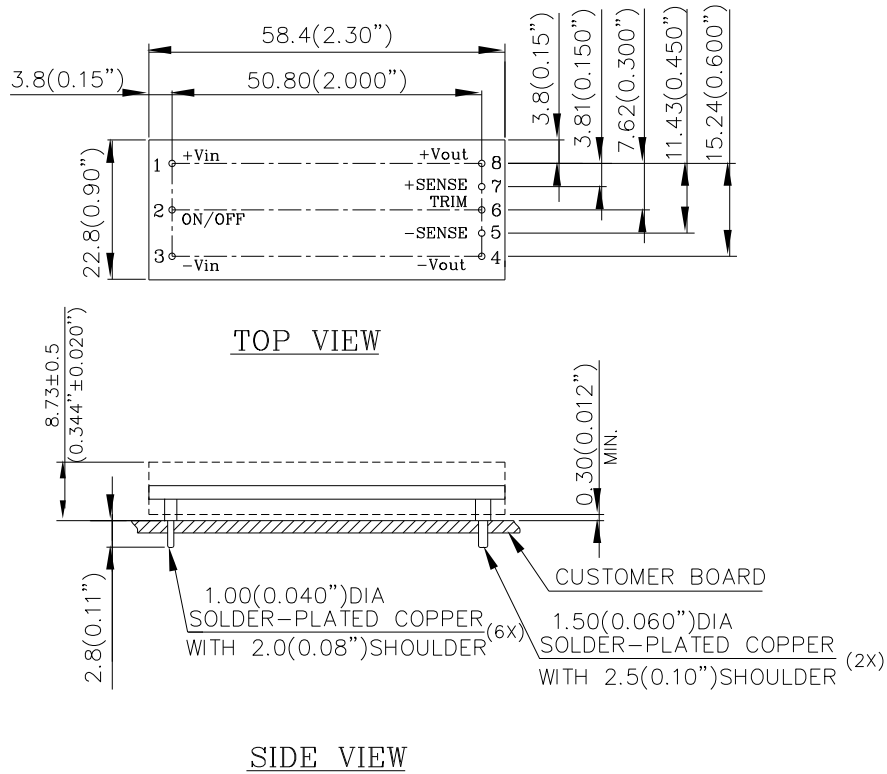

Figure 23: Output current vs. ambient temperature and air velocity @ Vin=48V (Transverse orientation, airflow from Vin- to Vin+)

MECHANICAL DRAWING (WITHOUT HEAT SPREADER)



NOTES:

DIMENSIONS ARE IN MILLIMETERS AND (INCHES)

TOLERANCES: X.Xmm ± 0.5mm (X.XX in. ± 0.02 in.)

X.XXmm ± 0.25mm (X.XXX in. ± 0.010 in.)

NOTE: have a typical height of the lowest component (who has to dissipate) of 7.25mm with a tolerance plus max height module/minus 0 mm.

<u>Pin No.</u>	<u>Name</u>	<u>Function</u>
1	+Vin	Positive input voltage
2	ON/OFF	Remote ON/OFF
3	-Vin	Negative input voltage
4	-Vout	Negative output voltage
5	-Sense	Negative remote sense
6	Trim	Output voltage trim
7	+Sense	Positive remote sense
8	+Vout	Positive output voltage

Pin Specification:

Pins 1-3,5-7 1.00mm (0.040") diameter

Pins 4 & 8 1.50mm (0.059") diameter

Note: All pins are copper alloy with matte-tin(Pb free) plated over Nickel underplating.

PART NUMBERING SYSTEM

E	36	S	R	120	04	N	K	F	A
Form Factor	Input Voltage	Number of Outputs	Product Series	Output Voltage	Output Current	ON/OFF Logic	Pin Length		Option Code
E- Eighth Brick	24/48-18V~60V	S- Single	R – Regular product	12V	4A	N- Negative	K-0.11"	Space- RoHs 5/6 F- RoHS 6/6 (Lead Free)	A- Standard Functions

CONTACT: www.deltaww.com/dcdc

USA:

Telephone:
East Coast: 978-656-3993
West Coast: 510-668-5100
Fax: (978) 656 3964
Email: DCDC@delta-corp.com

Europe:

Phone: +31-20-655-0967
Fax: +31-20-655-0999
Email: DCDC@delta-es.com

Asia & the rest of world:

Telephone: +886 3 4526107 x 6220~6224
Fax: +886 3 4513485
Email: DCDC@delta.com.tw

WARRANTY

Delta offers a two (2) year limited warranty. Complete warranty information is listed on our web site or is available upon request from Delta.

Information furnished by Delta is believed to be accurate and reliable. However, no responsibility is assumed by Delta for its use, nor for any infringements of patents or other rights of third parties, which may result from its use. No license is granted by implication or otherwise under any patent or patent rights of Delta. Delta reserves the right to revise these specifications at any time, without notice.

Mouser Electronics

Authorized Distributor

Click to View Pricing, Inventory, Delivery & Lifecycle Information:

Delta:

[E36SR12004NKFA](#)