

InSb photoconductive detector P6606 series

Thermoelectrically cooled detectors capable of long-term measurements

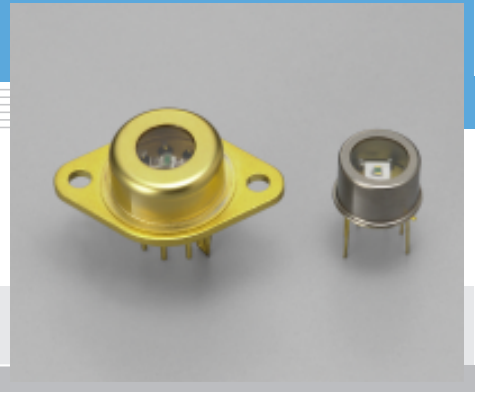

Features

- Thermoelectric cooling ensures high speed and high sensitivity up to 6.5 μm .
- Photoconductive element that changes electrical resistance by input of IR radiation
- Easy-to-use detector/preamp modules are also available.

Applications

- Environment measurements (gas analysis, etc.)
- Radiation thermometers (5 μm band)
- FTIR
- IR laser detection

Accessories (optional)

- Heatsink for one-stage TE-cooled type A3179
- Heatsink for two-stage TE-cooled type A3179-01
- Heatsink for three-stage TE-cooled type A3179-04
- Temperature controller C1103-05 (-75 to -25 °C)
C1103-07 (-30 to +20 °C)
- Preamp C5185
- Infrared detector module with preamp P4631-03 (P6606-310)

Specifications / Absolute maximum ratings

Type No.	Dimensional outline/ Window material *1	Package	Cooling	Active area (mm)	Absolute maximum ratings				
					Thermistor power dissipation (mW)	TE-cooler power dissipation (A)	Allowable current (mA)	Operating temperature Topr (°C)	Storage temperature Tstg (°C)
P6606-110	①/S	TO-8	One-stage TE-cooled	1 × 1	0.2	1.5	40	-40 to +60	-55 to +60
P6606-210			Two-stage TE-cooled			1.0			
P6606-305	②/S	TO-3	Three-stage TE-cooled	0.5 × 0.5	1.0	20	-40 to +60	-55 to +60	
P6606-310				1 × 1		40			
P6606-320				2 × 2		60			

*1: Window material S: Sapphire glass

Electrical and optical characteristics (Typ. unless otherwise noted)

Type No.	Measurement condition Element temperature T (°C)	Peak sensitivity wavelength λ_p (μm)	Cut-off wavelength λ_c (μm)	Photo *2 sensitivity S $\lambda = \lambda_p$ (V/W)	D* (500, 1200, 1)		D* (λ_p , 1200, 1) (cm·Hz ^{1/2} /W)	Rise time tr 0 to 63 % (μs)	Dark resistance Rd (Ω)
					Min. (cm·Hz ^{1/2} /W)	Typ. (cm·Hz ^{1/2} /W)			
	P6606-110	-10	5.5	6.7	10	7×10^7	2×10^8	1×10^9	0.4
P6606-210	-30	6.5		50	1.5×10^8	5×10^8	2.5×10^9	25	
P6606-305	-60	2500		1×10^9	2×10^9	1×10^{10}	150		
P6606-310		6.3		650	1×10^9	2×10^9	1×10^{10}	80	
P6606-320		150		5×10^8	1×10^9	5×10^9	80		

*2: Photo sensitivity changes with the bias current. The values in the above table are measured with the optimum bias current.

■ Spectral response

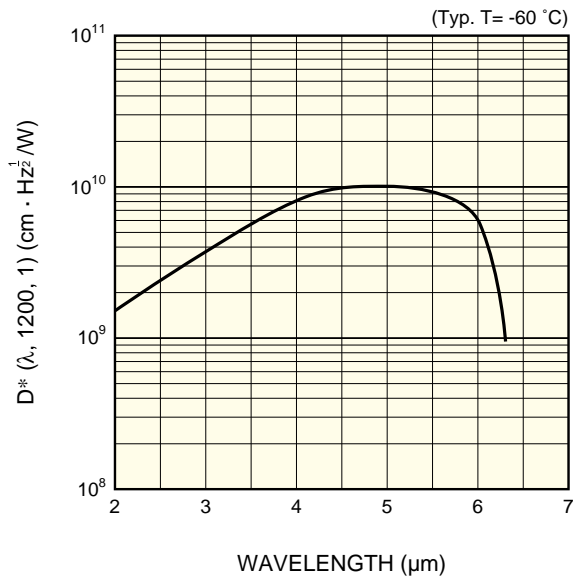

KIRDB0166EB

■ D^* vs. element temperature

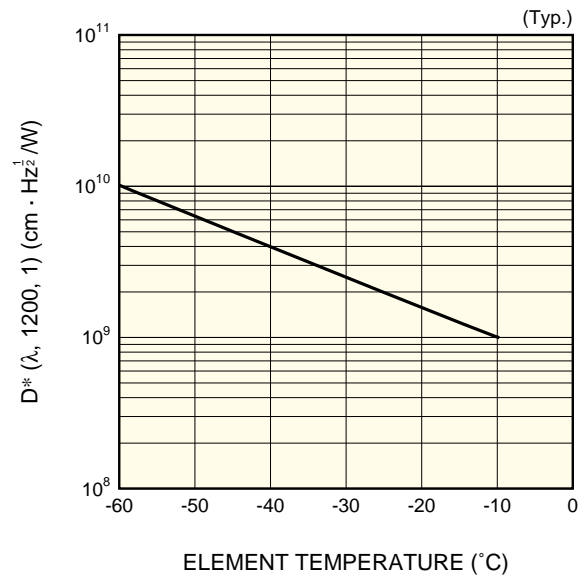

KIRDB0167EA

■ Thermistor temperature characteristic

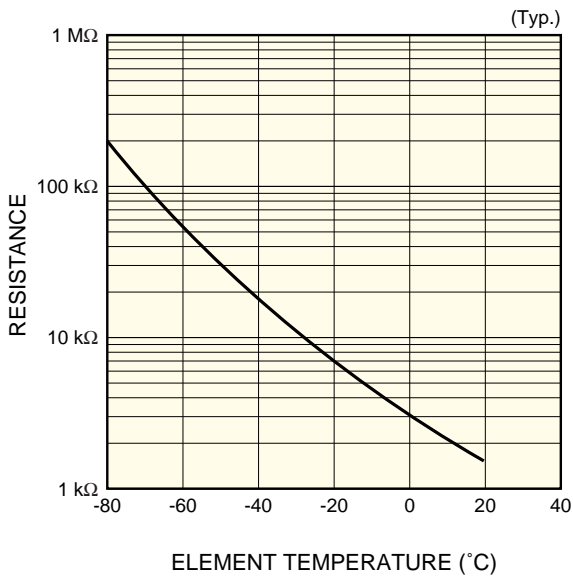

KIRDB0168EA

■ Cooling characteristics of TE-cooler

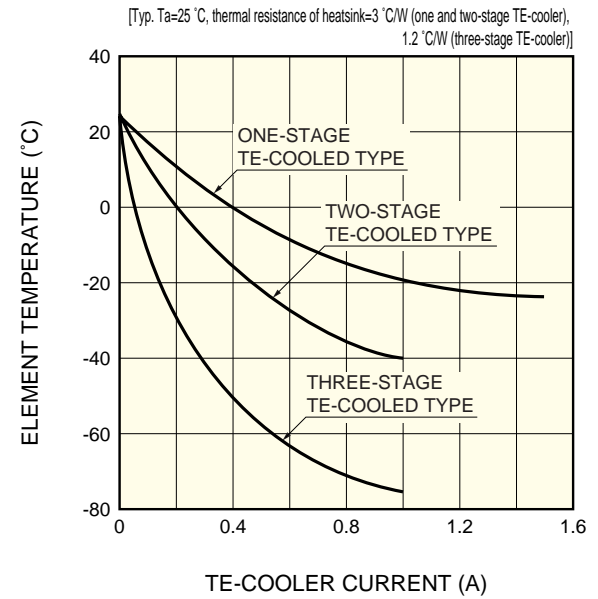

KIRDB0177EA

■ Current vs. voltage of TE-cooler

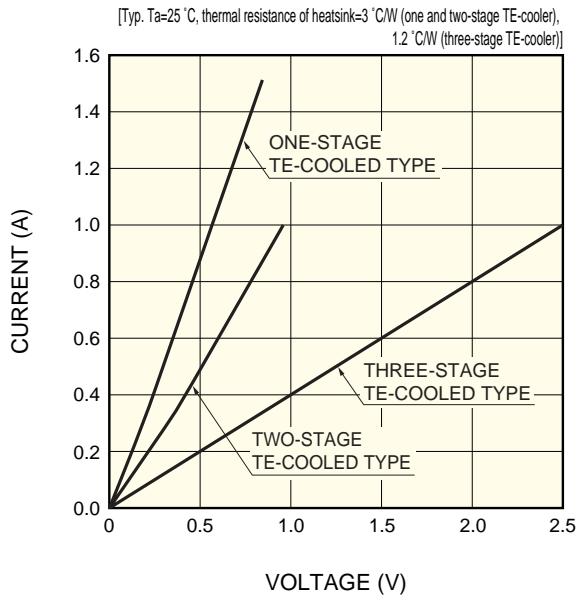

KIRDB0176EB

■ Measurement circuit

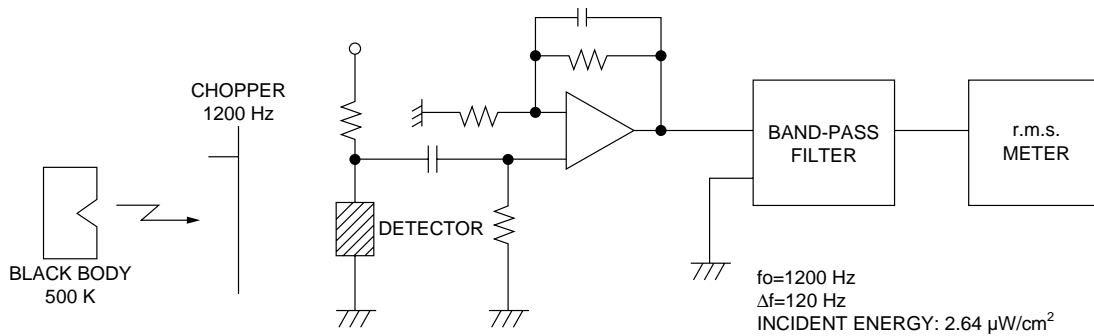

KIRDC0005EA

Dimensional outlines (unit: mm)

① P6606-110/-210

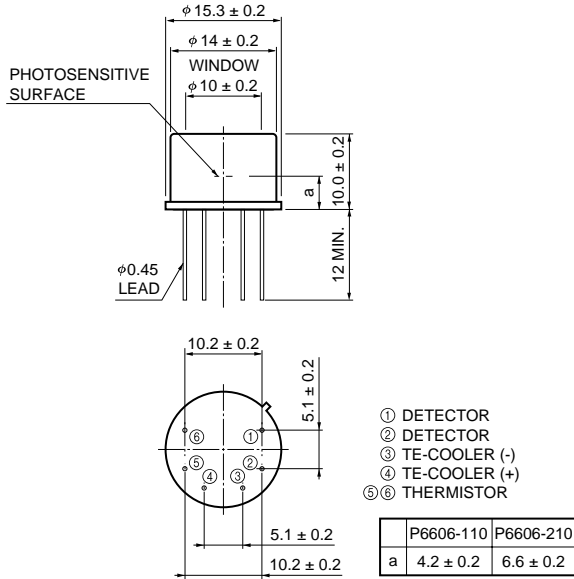

KIRDA0126EA

② P6606-305/-310/-320

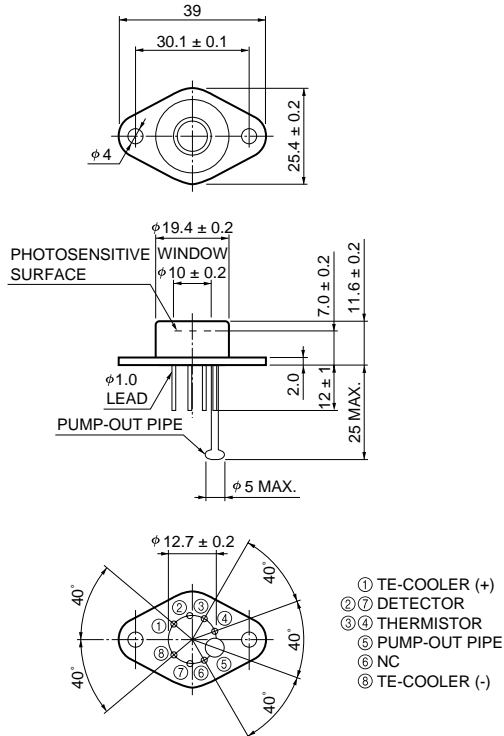

KIRDA0127EB

HAMAMATSU

Information furnished by HAMAMATSU is believed to be reliable. However, no responsibility is assumed for possible inaccuracies or omissions. Specifications are subject to change without notice. No patent rights are granted to any of the circuits described herein. ©2004 Hamamatsu Photonics K.K.

HAMAMATSU PHOTONICS K.K., Solid State Division

1126-1 Ichino-cho, Higashi-ku, Hamamatsu City, 435-8558 Japan, Telephone: (81) 53-434-3311, Fax: (81) 53-434-5184, <http://www.hamamatsu.com>

U.S.A.: Hamamatsu Corporation, 360 Foothill Road, P.O.Box 6910, Bridgewater, N.J. 08807-0910, U.S.A., Telephone: (1) 908-231-0960, Fax: (1) 908-231-1218

Germany: Hamamatsu Photonics Deutschland GmbH, Arzbergerstr. 10, D-82211 Herrsching am Ammersee, Germany, Telephone: (49) 08152-3750, Fax: (49) 08152-2658

France: Hamamatsu Photonics France S.A.R.L.: 19, Rue du Saule Trapu, Parc du Moulin de Massy, 91882 Massy Cedex, France, Telephone: 33-(1) 69 53 71 00, Fax: 33-(1) 69 53 71 10

United Kingdom: Hamamatsu Photonics UK Limited: 2 Howard Court, 10 Tewin Road, Welwyn Garden City, Hertfordshire AL7 1BW, United Kingdom, Telephone: (44) 1707-294888, Fax: (44) 1707-325777

North Europe: Hamamatsu Photonics Norden AB: Smidesvägen 12, SE-171 41 Solna, Sweden, Telephone: (46) 8-509-031-00, Fax: (46) 8-509-031-01

Italy: Hamamatsu Photonics Italia S.R.L.: Strada della Moia, 1/E, 20020 Arese, (Milano), Italy, Telephone: (39) 02-935-81-733, Fax: (39) 02-935-81-741