

# Photosensor Modules

**HAMAMATSU**

## H8249 Series



The H8249 series photosensor modules incorporate a 28-mm (1-1/8") diameter side-on photomultiplier tube, a high-voltage power supply circuit and a low noise amplifier. Two types of amplifiers are available with a current-to-voltage conversion factor of 1 V/μA or 0.1 V/μA and a frequency bandwidth of DC to 20 kHz or DC to 200 kHz. Three types of photomultiplier tubes are provided as standard lineups for general applications in the visible range, UV to visible range requiring low-noise, and UV to near IR range.

### Product Variations

Type No.	Spectral Response	Current-to-Voltage Conversion Factor	Frequency Bandwidth	Features
H8249-001	300 nm to 650 nm	1 V/μA	DC to 20 kHz	For general applications in visible range
H8249-011	185 nm to 680 nm			For general applications in UV to visible range
H8249-101	185 nm to 900 nm			High sensitivity in UV to near IR range. Uses photomultiplier tube with meshless grid for excellent uniformity.
H8249-002	300 nm to 650 nm	0.1 V/μA	DC to 200 kHz	For general applications in visible range
H8249-012	185 nm to 680 nm			For general applications in UV to visible range
H8249-102	185 nm to 900 nm			High sensitivity in UV to near IR range. Uses photomultiplier tube with meshless grid for excellent uniformity.

### Specifications

Parameter		H8249 Series			Unit	
Suffix		-001 / -002	-011 / -012	-101 / -102	—	
Input Voltage		±11.5 to ±15.5			V	
Max. Input Voltage		±18			V	
Max. Input Current		+45/-1 (-001/-011/-101), +55/-15 (-002/-012/-102)			mA	
Max. Control Voltage		+1.2 (Input Impedance 100 kΩ)			V	
Recommended Control Voltage Adjustment Range		+0.3 to +1.1			V	
Effective Area		4 × 20			mm	
Sensitivity Adjustment Range		1: 10 <sup>4</sup>			—	
Peak Sensitivity Wavelength		400			nm	
Cathode	Luminous Sensitivity	Min.	30	40	140	μA/lm
		Typ.	60	60	250	
	Blue Sensitivity Index (CS 5-58)	Typ.	7.1	6.4	8.0	—
	Red/White Ratio	Typ.	—	—	0.3	—
Radiant Sensitivity *1		Typ.	60	60	74	mA/W
Suffix (with internal 20 kHz amp)		-001	-011	-101		
Anode	Luminous Sensitivity *2	Min.	5.0 × 10 <sup>7</sup>	2.0 × 10 <sup>8</sup>	4.0 × 10 <sup>8</sup>	V/lm
		Typ.	6.0 × 10 <sup>8</sup>	4.0 × 10 <sup>8</sup>	2.5 × 10 <sup>9</sup>	
	Radiant Sensitivity *1 *2	Typ.	600	400	740	V/nW
	Voltage Output Depending on PMT Dark Current *2 *3 *4	Typ.	5	0.1	3	mV
Max.	50	2	50			
Max. Output Signal Voltage		+10 (Load resistance 10 kΩ)			V	
Current-to-Voltage Conversion Factor		1			V/μA	
Suffix (with internal 200 kHz amp)		-002	-012	-102		
Anode	Luminous Sensitivity *2	Min.	5.0 × 10 <sup>6</sup>	2.0 × 10 <sup>7</sup>	4.0 × 10 <sup>7</sup>	V/lm
		Typ.	6.0 × 10 <sup>7</sup>	4.0 × 10 <sup>7</sup>	2.5 × 10 <sup>8</sup>	
	Radiant Sensitivity *1 *2	Typ.	60	40	74	V/nW
	Voltage Output Depending on PMT Dark Current *2 *3 *4	Typ.	0.5	0.01	0.3	mV
Max.	5	0.2	5			
Max. Output Signal Voltage		+10 (Load resistance 10 kΩ)			V	
Current-to-Voltage Conversion Factor		0.1			V/μA	
<b>H8249 series</b>						
Offset Voltage		Typ.	±3			mV
Ripple Noise *2 *5 (peak to peak)		Max.	0.6			mV
Settling Time *6		Max.	0.2			s
Operating Ambient Temperature *7		+5 to +45			°C	
Storage Temperature *7		-20 to +50			°C	
Weight		220			g	

\*1: Measured at the peak sensitivity wavelength \*2: Control voltage = +1.0 V \*3: After 30 minutes storage in darkness

\*4: Output of anode dark current \*5: Cable RG-174/U, Cable length 450 mm, Load resistance = 1 MΩ, Load capacitance = 22 pF

\*6: The time required for the output to reach a stable level following a change in the control voltage from +1.0 V to +0.5 V. \*7: No condensation

### Characteristics (Anode radiant sensitivity, PMT gain)

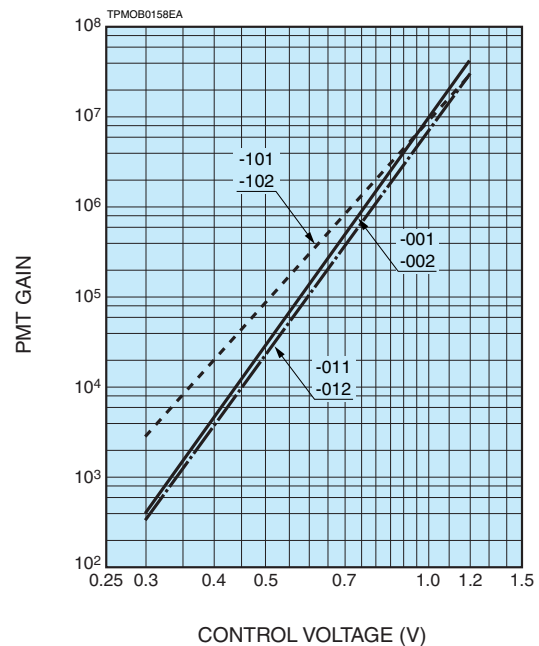
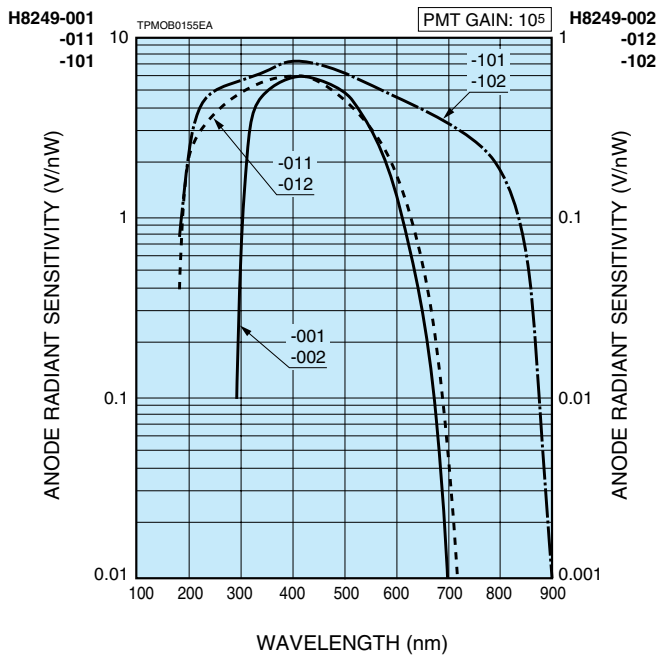

### Sensitivity Adjustment Method

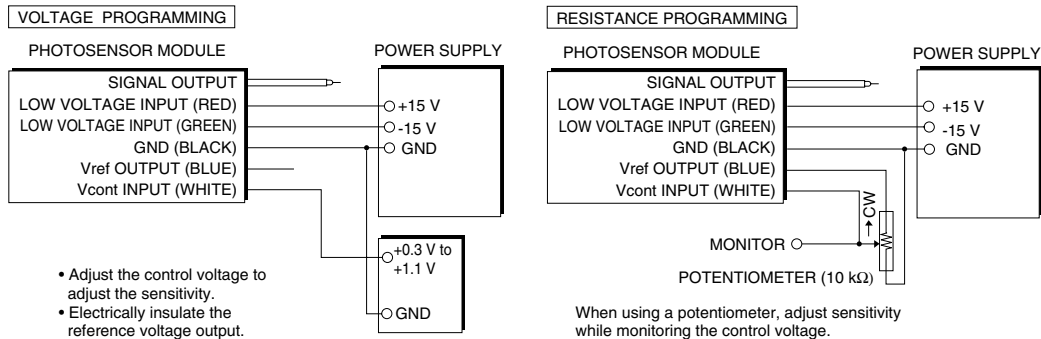

TPMOC0162ED

### Dimensional Outlines (Unit: mm)

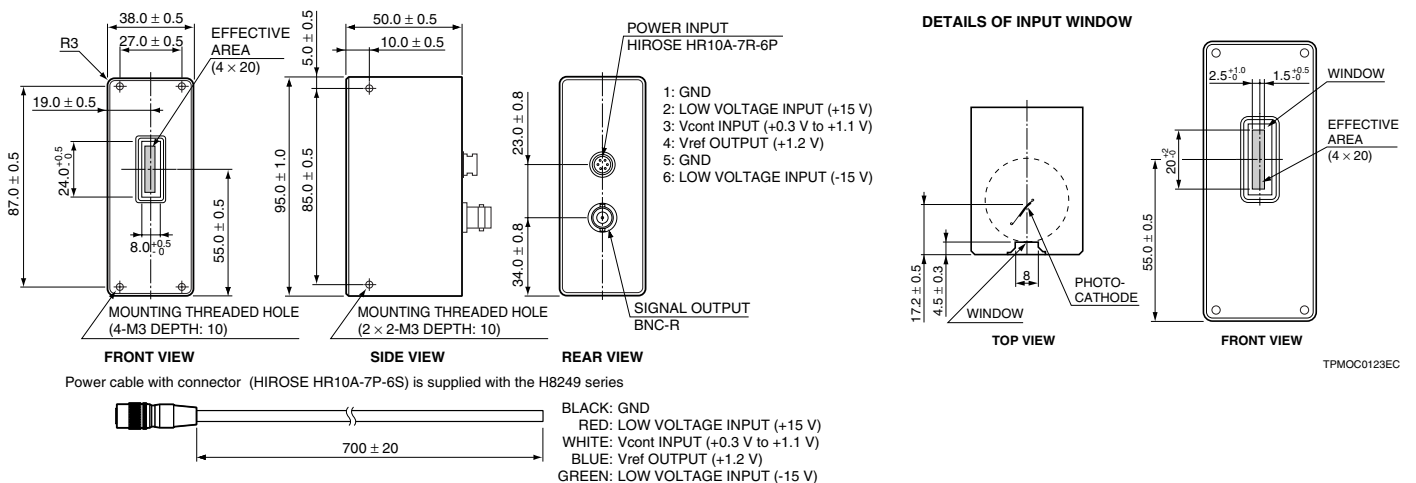

TPMOA0022EC

TPMOC0123EC