

## Description

The 2842/43/44/45 are fixed frequency current mode PWM controller. They are specially designed for OFF-Line and DC to DC converter applications with a minimal external components. Internally implemented circuits include a trimmed oscillator for precise duty cycle control, a temperature compensated reference, high gain error amplifier, current sensing comparator, and a high current totem pole output ideally suited for driving a power MOSFET. Protection circuitry includes built undervoltage lockout and current limiting. The 2842 and 2844 have UVLO thresholds of 16V (on) and 10V (off). The corresponding thresholds for the 2843/45 are 8.4V (on) and 7.6V (off). The 2842 and 2843 can operate within 100% duty cycle.

The 2844 and 2845 can operate within 50% duty cycle.

The 284X has Start-Up Current 0.5mA (typ).

## Features

- Low Start-Up and Operating Current
- High Current Totem Pole Output
- Undervoltage Lockout With Hysteresis
- Operating Frequency Up To 500KHz

## Pin Connection

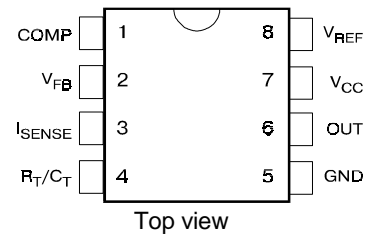

## Block diagram

(toggle flip flop used only in 2844, 2845)

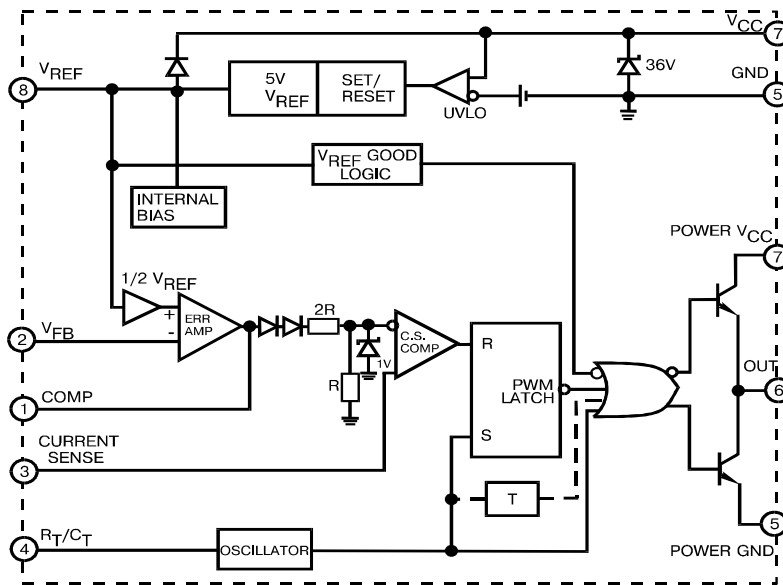

## Absolute Maximum Ratings

Symbol	Parameter	Maximum	Units
$V_{CC}$	Supply Voltage (low impedance source)	30	V
$I_o$	Output Current	$\pm 1$	A
$V_i$	Input Voltage (Analog Inputs pins 2,3)	-0.3 to 5.5	V
$I_{SINK(E.A)}$	Error Amp Output Sink Current	10	mA
$P_o$	Power Dissipation ( $T_A=25^\circ C$ )	1	W
Tstg	Storage Temperature Range	-65 to 150	$^\circ C$
$T_L$	Lead Temperature (soldering 5 sec.)	260	$^\circ C$
$T_A$	Operating Ambient Temperature	-25 to +85	$^\circ C$

## Electrical characteristics

(\* $V_{CC}=15V$ ,  $R_T=10k\Omega$ ,  $C_T=3.3nF$ ,  $T_A=0^{\circ}C$  to  $+70^{\circ}C$ , unless otherwise specified)

Characteristics	Symbol	Test Conditions	Min	Typ	Max	Units	
<b>Reference Section</b>							
Reference Output Voltage	$V_{REF}$	$T_J = 25^{\circ}C$ , $I_{REF} = 1\text{ mA}$	4.9	5.0	5.1	V	
Line Regulation	$\Delta V_{REF}$	$12V \leq V_{CC} \leq 25\text{ V}$		6.0	20	mV	
Load Regulation	$\Delta V_{REF}$	$1\text{ mA} \leq I_{REF} \leq 20\text{mA}$		6.0	25		
Short Circuit Output Current	$I_{SC}$	$T_A = 25^{\circ}C$		-100	-180	mA	
<b>Oscillator Section</b>							
Oscillation Frequency	f	$T_J = 25^{\circ}C$	284X	47	50	57	KHz
			284X	47	52	57	
Frequency Change with Voltage	$\Delta f/\Delta V_{CC}$	$12V \leq V_{CC} \leq 25\text{ V}$		0.05	1.0	%	
Oscillator Amplitude	$V_{(OSC)}$	(peak to peak)		1.6		V	
<b>Error Amplifier Section</b>							
Input Bias Current	$I_{BIAS}$	$V_{FB}=3V$		-0.1	-2	$\mu A$	
Input Voltage	$V_{(I.E.A)}$	$V_{pin1} = 2.5V$	2.42	2.5	2.58	V	
Open Loop Voltage Gain	$A_{VOL}$	$2V \leq V_o \leq 4V$	65	90		dB	
Power Supply Rejection Ratio	PSRR	$12V \leq V_{CC} \leq 25\text{ V}$	60	70			
Output Sink Current	$I_{SINK}$	$V_{pin2} = 2.7V$ , $V_{pin1} = 1.1V$	2	7		mA	
Output Source Current	$I_{SOURCE}$	$V_{pin2} = 2.3V$ , $V_{pin1} = 5V$	-0.5	-1.0		mA	
High Output Voltage	$V_{OH}$	$V_{pin2} = 2.3V$ , $R_L = 15K\Omega$ to GND	5.0	6.0		V	
Low Output Voltage	$V_{OL}$	$V_{pin2} = 2.7V$ , $R_L = 15K\Omega$ to PIN 8		0.8	1.1		
<b>Current Sense Section</b>							
Gain	$G_V$	(Note 1 & 2)	2.85	3.0	3.15	V/V	
Maximum Input Signal	$V_{(MAX)}$	$V_{pin1} = 5V$ (Note1)	0.9	1.0	1.1	V	
Supply Voltage Rejection	SVR	$12V \leq V_{CC} \leq 25\text{ V}$ (Note 1)		70		dB	
Input Bias Current	$I_{BIAS}$	$V_{pin3} = 3V$		-3.0	-10	$\mu A$	
<b>Output Section</b>							
Low Output Voltage	$V_{OL}$	$I_{SINK} = 20\text{ mA}$		0.08	0.4	V	
		$I_{SINK} = 200\text{ mA}$		1.4	2.2		
High Output Voltage	$V_{OH}$	$I_{SINK} = 20\text{ mA}$	13	13.5		V	
		$I_{SINK} = 200\text{ mA}$	12	13.0			
Rise Time	$t_r$	$T_J = 25^{\circ}C$ , $C_L = 1nF$ (Note 3)		45	150	nS	
Fall Time	$t_f$	$T_J = 25^{\circ}C$ , $C_L = 1nF$ (Note 3)		35	150		
<b>Undervoltage Lockout Section</b>							
Start Theshold	$V_{TH(ST)}$	2842/44	14.5	16.0	17.5	V	
		2843/45	7.8	8.4	9.0		
Min. Operating Voltage (After Turn On)	$V_{OPR(min)}$	2842/44	8.5	10	11.5	V	
		2843/45	7.0	7.6	8.2		
<b>PWM Section</b>							
Max. Duty Cycle	$D_{(MAX)}$	2842/43	95	97	100	%	
		2844/45	47	48	50		
Min. Duty Cycle	$D_{(MAX)}$				0		
<b>Total Standby Current</b>							
Start-Up Current	$I_{ST}$	284X		0.05		mA	
Operating Supply Current	$I_{CC (OPR)}$	$V_{pin3} = V_{pin2} = 0V$		13	17		
Zener Voltage	$V_Z$	$I_{CC}=25\text{ mA}$	30	38		V	

\* - Adjust  $V_{CC}$  above the start threshold before setting it to 15V.

Note 1: Parameter measured at trip point of latch with  $V_{pin2}=0$ .

Note 2: Gain defined as  $A=\Delta V_{pin1}/\Delta V_{pin3}$ ;  $0 \leq V_{pin3} \leq 0.8V$ .

Note 3: These parameters, although guaranteed, are not 100% tested in production.

### Pin functions

N	Function	Description
1	COMP	This pin is the Error Amplifier output and is made for loop compensation.
2	V <sub>FB</sub>	This is the inverting input of the Error Amplifier. It is normally connected to the switching power supply output through a resistor divider.
3	I <sub>SENSE</sub>	A voltage proportional to inductor current is connected to this input. The PWM uses this information to terminate the output switch conduction.
4	R <sub>T</sub> /C <sub>T</sub>	The oscillator frequency and maximum Output duty cycle are programmed by connecting resistor R <sub>T</sub> to V <sub>ref</sub> and capacitor C <sub>T</sub> to ground.
5	GROUND	This pin is the combined control circuitry and power ground.
6	OUTPUT	This output directly drives the gate of a power MOSFET. Peak currents up to 1A are sourced and sink by this pin.
7	V <sub>CC</sub>	This pin is the positive supply of the integrated circuit.
8	V <sub>ref</sub>	This is the reference output. It provides charging current for capacitor C <sub>T</sub> through resistor R <sub>T</sub> .

### Application information

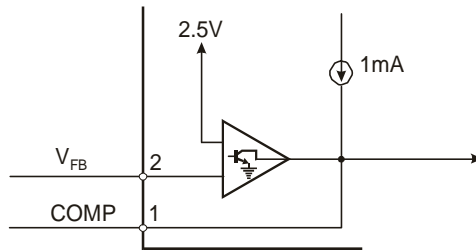

Figure 1. Error Amp Configuration

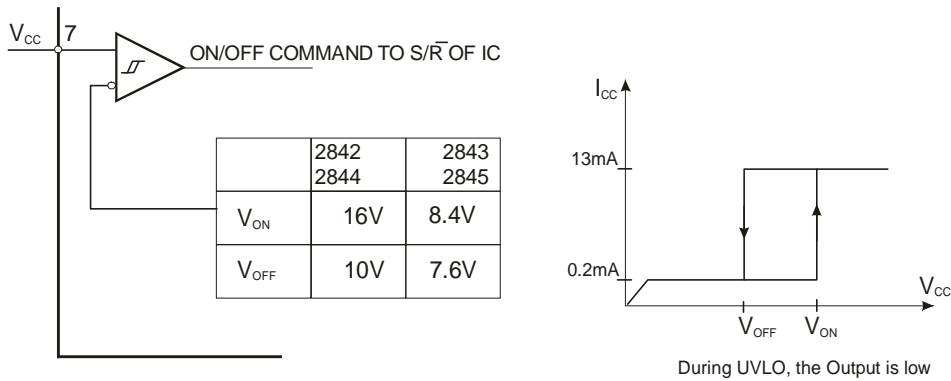

Figure 2. Undervoltage Lockout

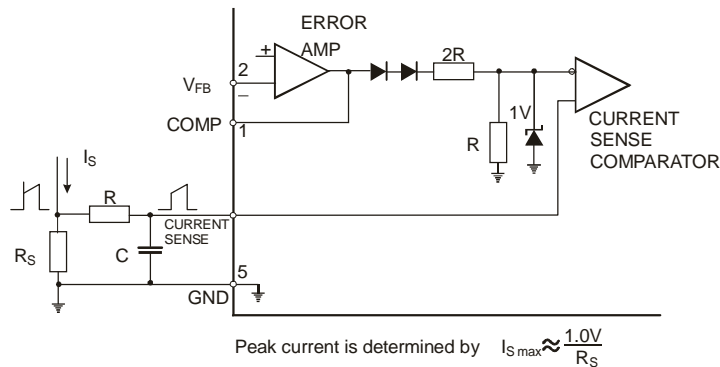

Figure 3. Current Sense Circuit

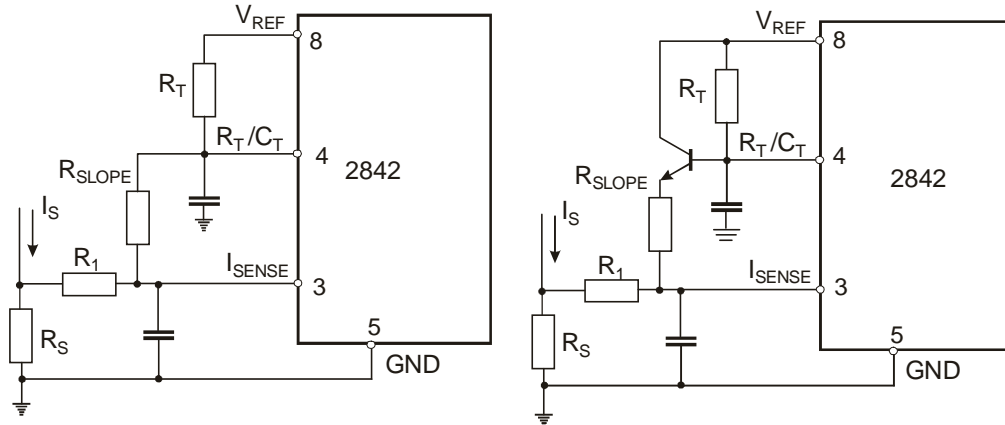
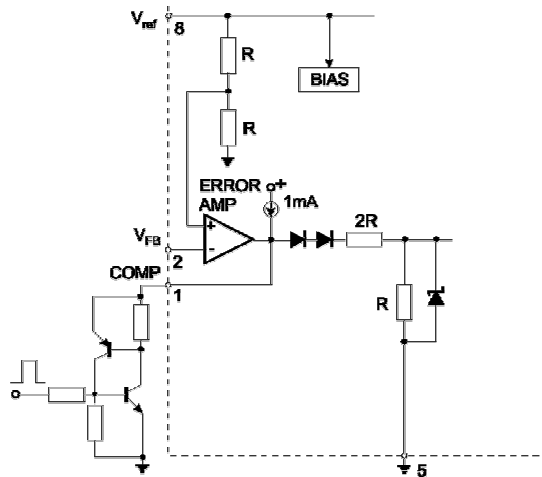
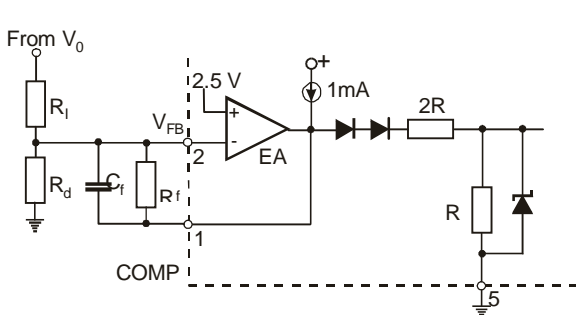

Figure 4. Slope Compensation Techniques



SCR must be selected for a holding current of less than 0.5mA.  
The simple two transistor circuit can be used in place of the SCR as shown.

Figure 5. Latched Shutdown



Error Amp compensation circuit for stabilizing any current-mode topology except for boost and flyback converters operating with continuous inductor current.

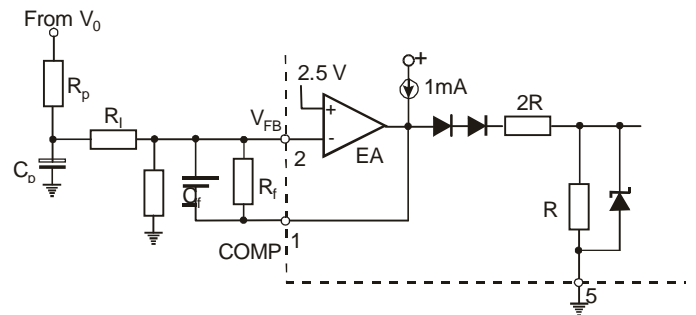

Error Amp compensation circuit for stabilizing current-mode boost and flyback topologies operating with continuous inductor current.

Figure 6. Error Amplifier Compensation

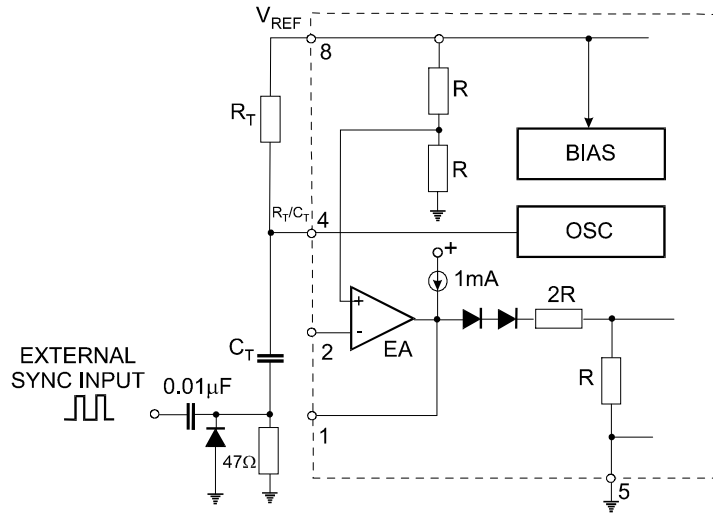

Figure 7. External Clock Synchronization

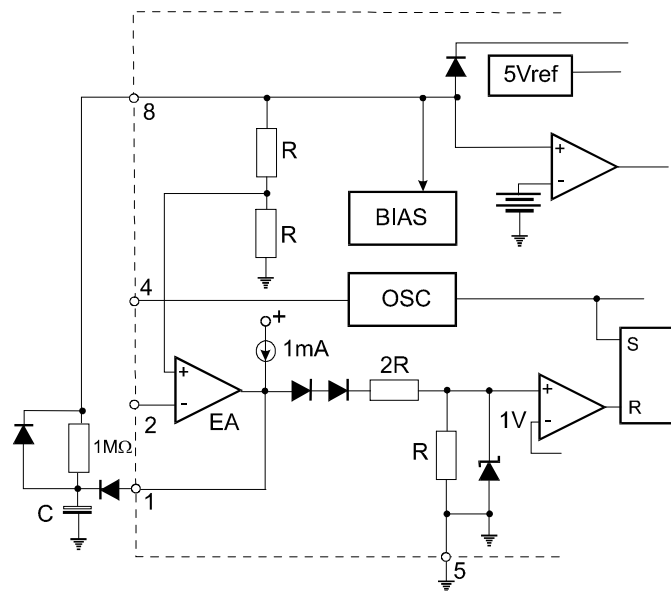

Figure 8. Soft-Start Circuit

Typical Performance Characteristics

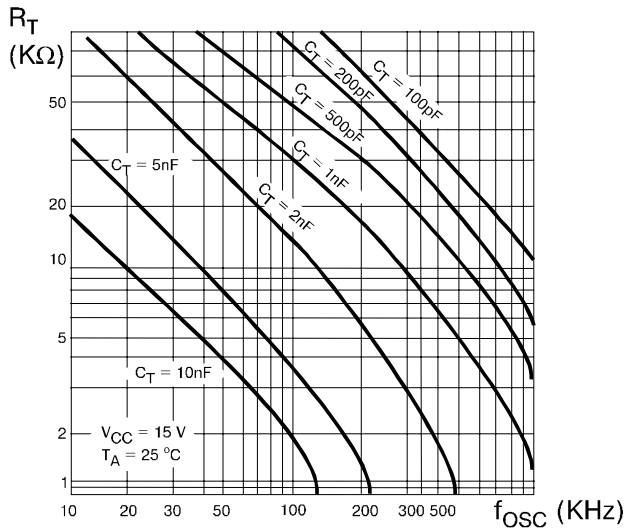

Figure 1. Timing Resistor vs. Oscillator Frequency

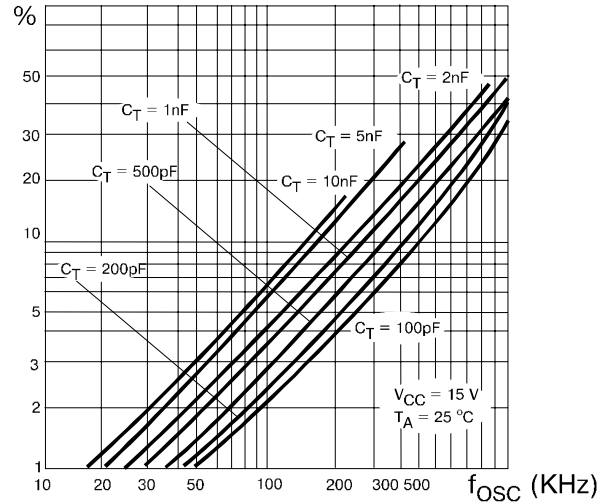

Figure 2. Output Dead-Time vs. Oscillator Frequency

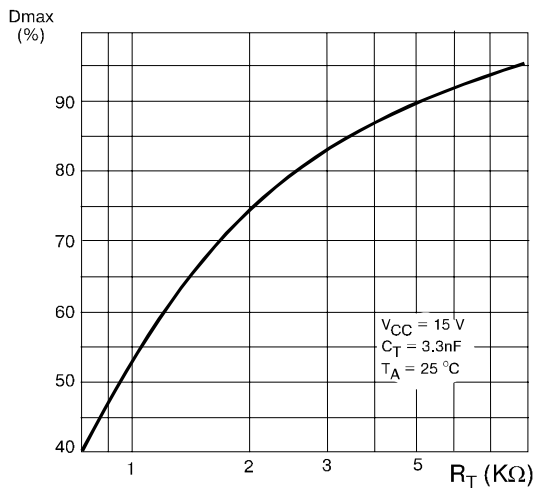

Figure 3. Maximum Output Duty Cycle vs. Timing Resistor (UC3842/43)

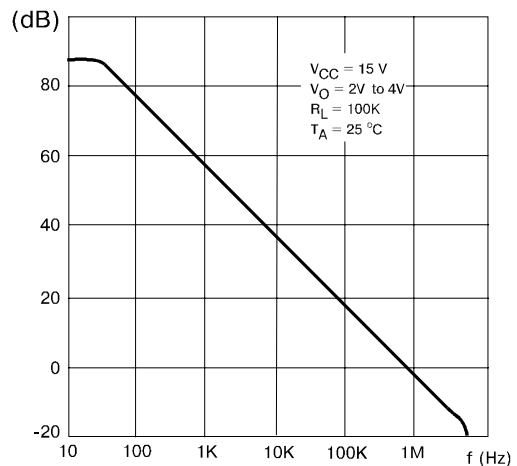

Figure 4. Error Amp Open-Loop Gain vs. Frequency

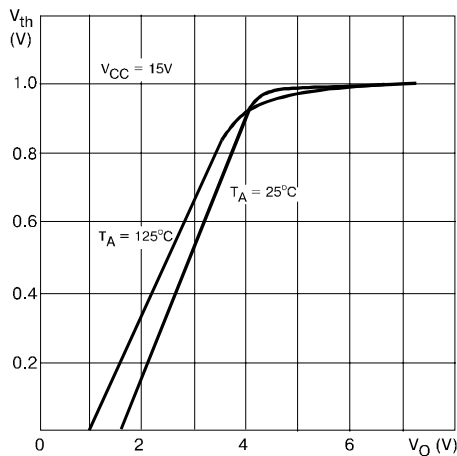

Figure 5. Current Sense Input Threshold vs. Error Amp Output Voltage

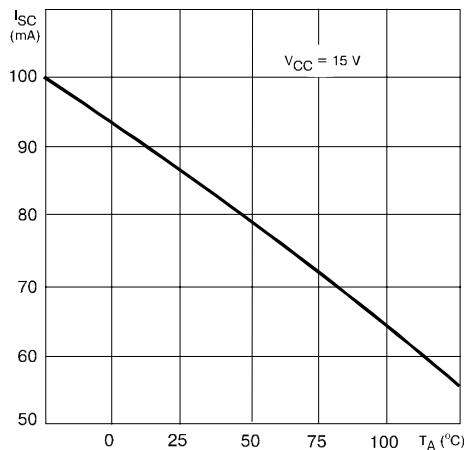

Figure 6. Reference Short Circuit Current vs. Temperature

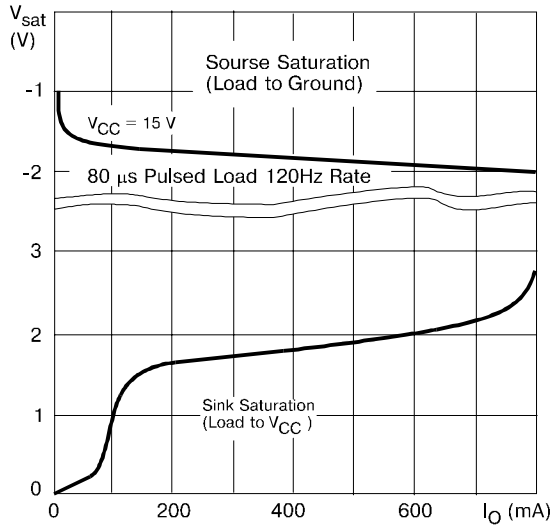

Figure 7. Output Saturation Voltage vs. Load Current  
 $T_A = 25^\circ\text{C}$

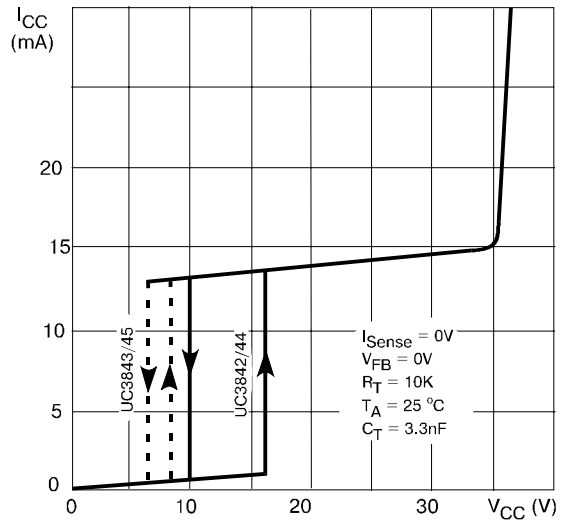

Figure 8. Supply Current vs. Supply Voltage

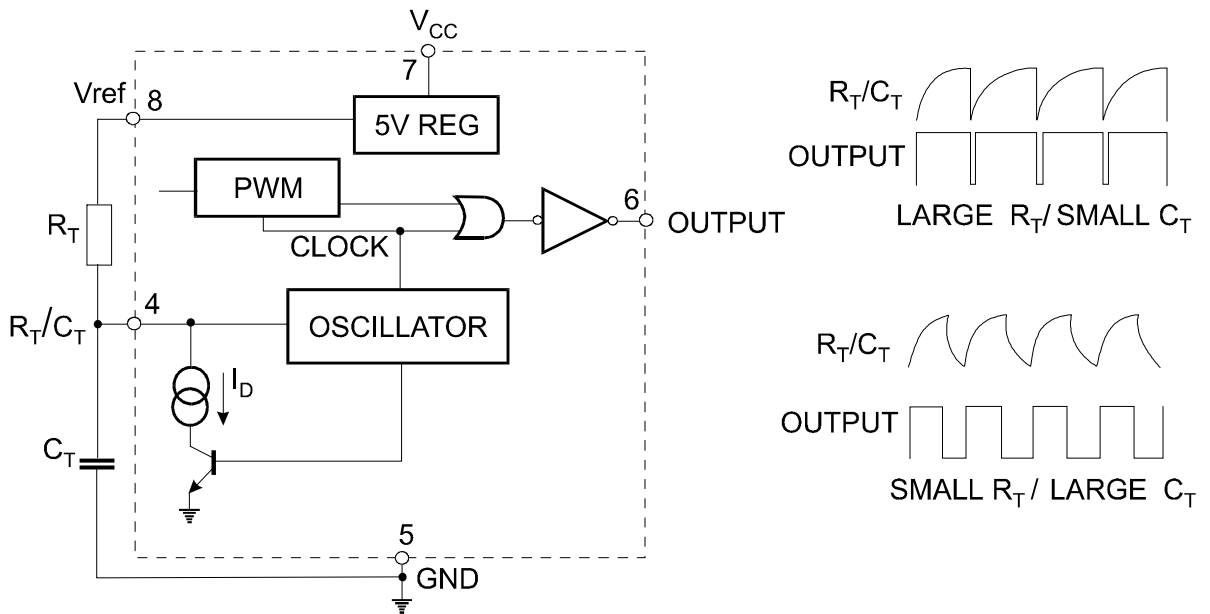
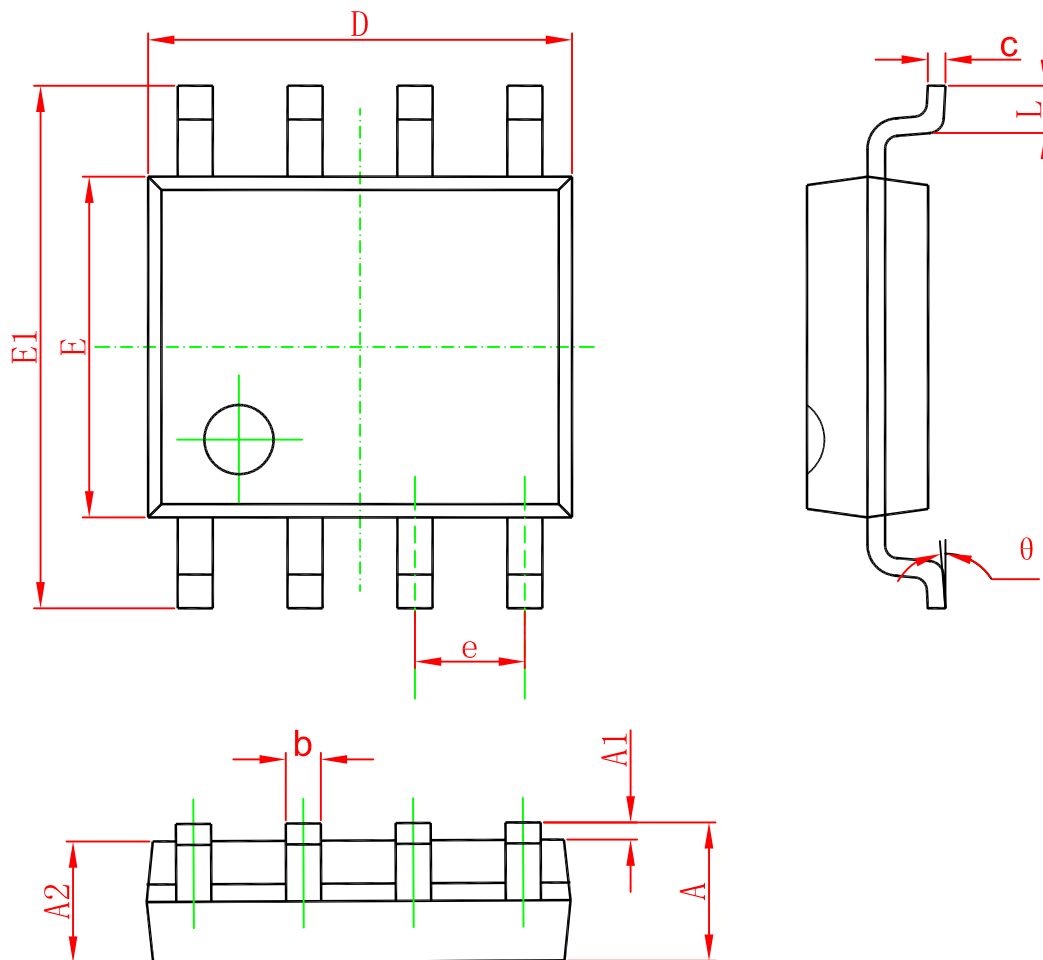

Figure 9. Oscillator and Output Waveforms

SOP-8



Symbol	Dimensions In Millimeters		Dimensions In Inches	
	Min	Max	Min	Max
A	1.350	1.750	0.053	0.069
A1	0.100	0.250	0.004	0.010
A2	1.350	1.550	0.053	0.061
b	0.330	0.510	0.013	0.020
c	0.170	0.250	0.006	0.010
D	4.700	5.100	0.185	0.200
E	3.800	4.000	0.150	0.157
E1	5.800	6.200	0.228	0.244
e	1.270(BSC)		0.050(BSC)	
L	0.400	1.270	0.016	0.050
θ	0°	8°	0°	8°



## Ordering information

Order code	Package	Baseqty	Deliverymode
UMW UC2842B	SOP-8	2500	Tape and reel
UMW UC2843B	SOP-8	2500	Tape and reel
UMW UC2844B	SOP-8	2500	Tape and reel
UMW UC2845B	SOP-8	2500	Tape and reel