

SOP-18 Plastic-Encapsulate Transistors

ULN2803 DARLINGTON TRANSISTOR (NPN)

Description

The ULN2803 device is a 40V, 500mA Darlington transistor array. The device consists of eight NPN Darlington pairs that feature high-voltage outputs with common-cathode clamp diodes for switching inductive loads. The collector-current rating of each Darlington pair is 500mA. The Darlington pairs may be connected in parallel for higher current capability.

Applications include relay drivers, hammer drivers, lamp drivers, display drivers (LED and gas discharge), line drivers, and logic buffers. The ULN2803 device has a 2.7-k Ω series base resistor for each Darlington pair for operation directly with TTL or 5-V CMOS devices.

Features

- 500-mA-Rated Collector Current (Single Output)
- High-Voltage Outputs: 40 V
- Output Clamp Diodes
- Inputs Compatible With Various Types of Logic

Applications

- Relay Drivers
- Hammer Drivers
- Lamp Drivers
- Line Drivers
- Logic Buffers
- Stepper Motors
- IP Camera
- HVAC Valve and LED Dot Matrix

Logic Diagram

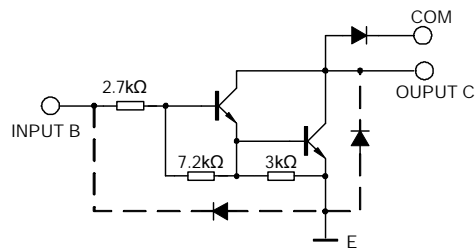
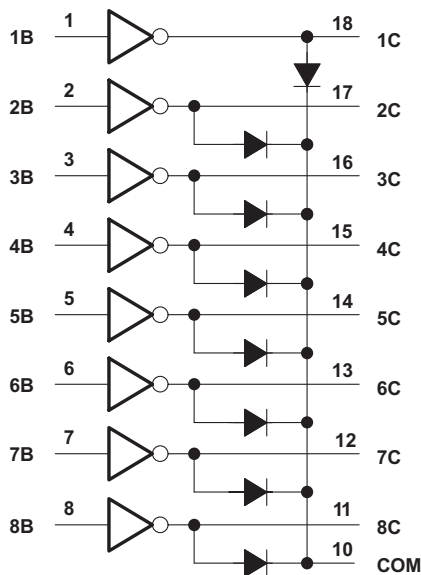

Note: The input and output parasitic diodes cannot be used as clamp diodes.

Pin Configuration and Functions

Package
SOP-18
Top View

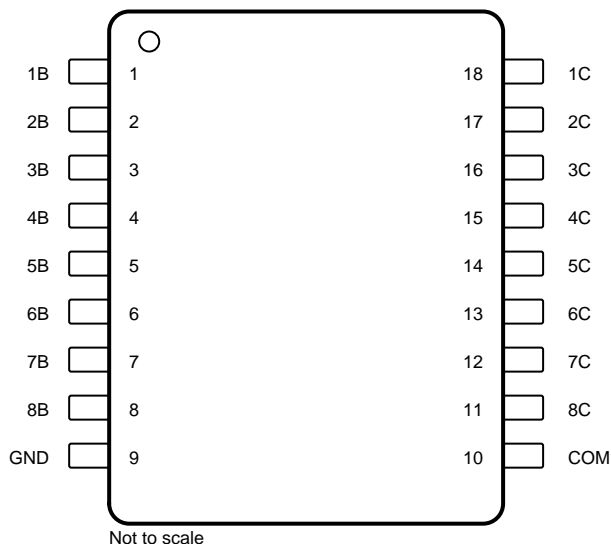

Pin Functions

PIN		TYPE	DESCRIPTION
NAME	NO.		
1B	1	I	Channel 1 through 8 Darlington base input
2B	2		
3B	3		
4B	4		
5B	5		
6B	6		
7B	7		
8B	8		
1C	18	O	Channel 1 through 8 Darlington collector output
2C	17		
3C	16		
4C	15		
5C	14		
6C	13		
7C	12		
8C	11		
GND	9	—	Common emitter shared by all channels (typically tied to ground)
COM	10	I/O	Common cathode node for flyback diodes (required for inductive loads)

Typical Characteristics

ABSOLUTE MAXIMUM RATING

PARAMETER	SYMBOL	ULN2803			UNIT
		MIN	TYP	MAX	
Output voltage	V_O			40	V
Input voltage	V_I			30	V
Collector current(continuous current)	I_C			500	mA
Base current(continuous current)	I_B			25	mA
Operating Ambient Temperature	T_A	0		70	°C
Operating Junction Temperature	T_J			125	°C
Storage Temperature	T_{stg}	-55		150	°C

ELECTRICAL CHARACTERISTICS ($T_a=25^\circ\text{C}$ unless otherwise specified)

PARAMETER		TEST CONDITIONS	ULN2803			UNIT
			MIN	TYP	MAX	
I_{CEX}	Collector cutoff current	$V_{CE} = 40\text{ V}, T_{amb}=+70^\circ\text{C}$			100.0	μA
		$V_{CE} = 40\text{ V}, T_{amb}=+25^\circ\text{C}$			50.0	μA
V_{CES}	Collector-emitter saturation voltage	$I_C = 350\text{ mA}, I_B=500\mu\text{A}$		1.1	1.6	V
		$I_C = 200\text{ mA}, I_B=350\mu\text{A}$		0.95	1.3	
		$I_C = 100\text{ mA}, I_B=250\mu\text{A}$		0.85	1.1	
$I_{I(ON)}$	Input current(ON)	$V_I = 3.85\text{ V}$		0.93	1.35	mA
$V_{I(ON)}$	Input voltage(ON)	$V_{CE} = 2.0\text{ V}, I_C=200\text{mA}$			2.4	V
		$V_{CE} = 2.0\text{ V}, I_C=250\text{mA}$			2.7	
		$V_{CE} = 2.0\text{ V}, I_C=300\text{mA}$			3.0	
$I_{I(OFF)}$	Input current(OFF)	$V_{CE} = 2.0\text{ V}, I_C=350\text{mA}$	50	100		μA
C_I	Input capacitance			15	30	pF
t_{ON}	On delay time	50%EI to 50%EO		0.25	1.0	μs
t_{OFF}	Off delay time	50%EI to 50%EO		0.25	1.0	μs
I_R	Clamp reverse current	$V_R = 40\text{ V}$	$T_A=+25^\circ\text{C}$		50.0	μA
			$T_A=+70^\circ\text{C}$		100.0	
V_F	Clamp forward voltage	$I_F=350\text{mA}$		1.5	2.0	V

Typical Characteristics Measurement

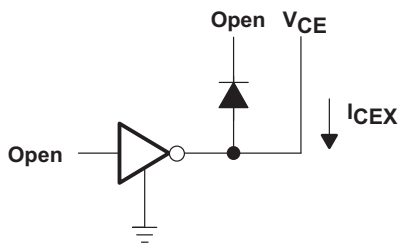

Figure 1. I_{CEX} Test Circuit

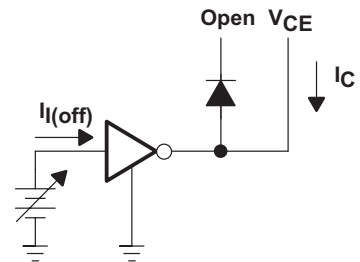

Figure 2. $I_{I(off)}$ Test Circuit

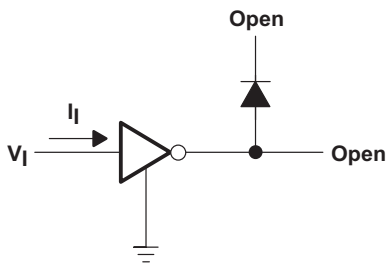

Figure 3. $I_{I(on)}$ Test Circuit

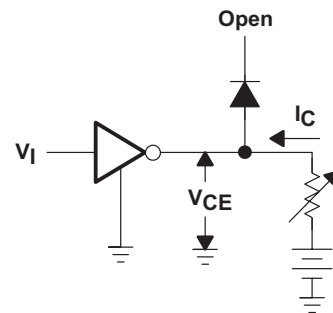

Figure 4. $V_{I(on)}$ Test Circuit

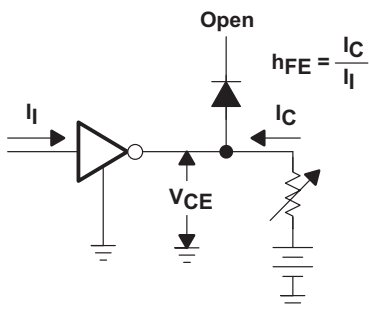

Figure 5. h_{FE} , $V_{CE(sat)}$ Test Circuit

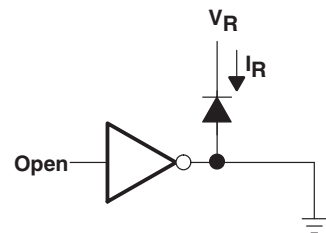

Figure 6. I_R Test Circuit

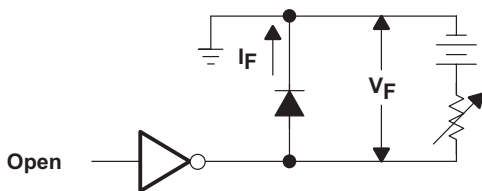

Figure 7. V_F Test Circuit

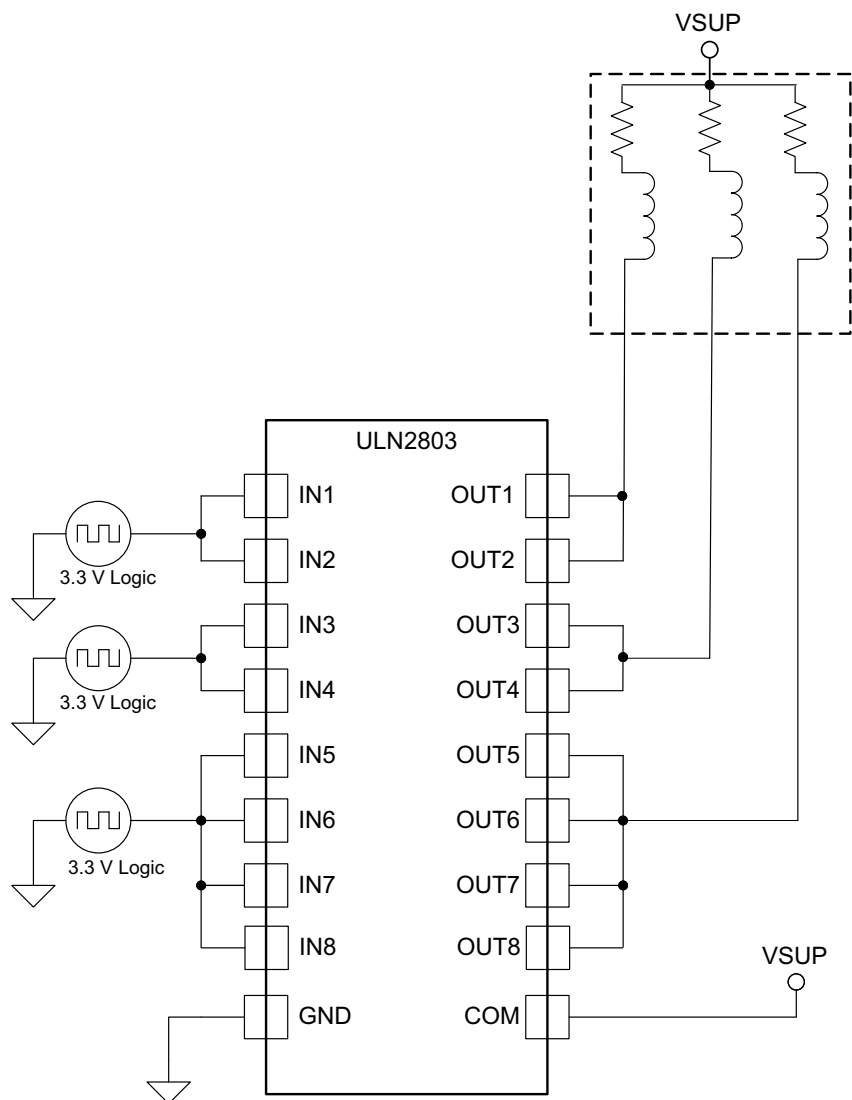
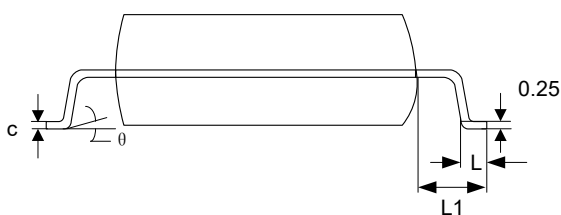
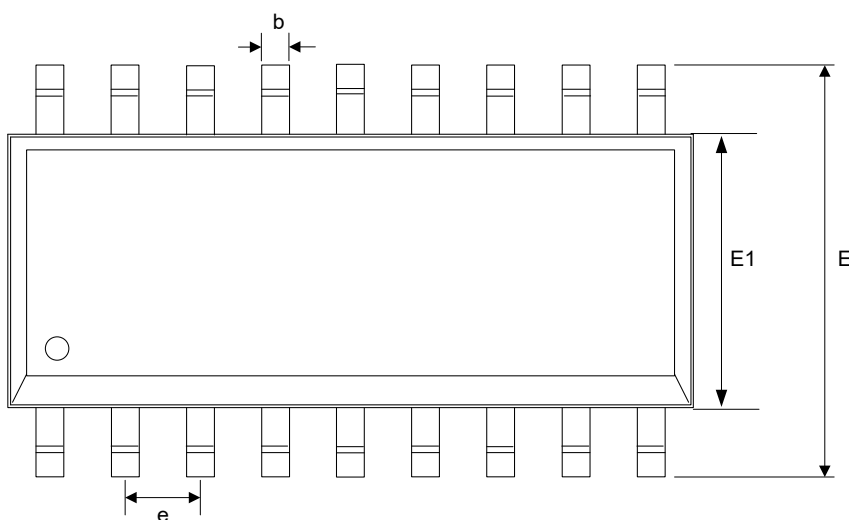
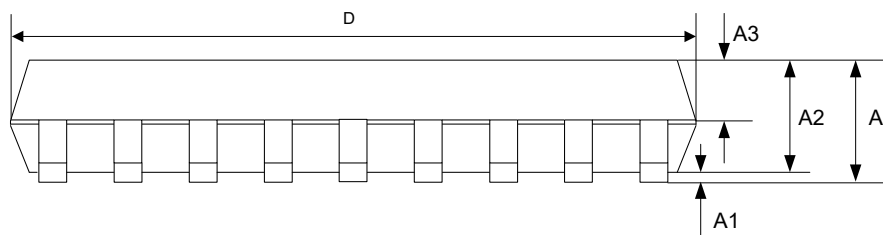

Figure 8. ULN2803 as Inductive Load Driver

SOP-18 Package Outline Dimensions



SYMBOL	MILLIMETER		
	MIN	NOM	MAX
A	-	-	2.65
A1	0.10	-	0.30
A2	2.25	2.3	2.35
A3	0.97	1.02	1.07
b	0.35	-	0.44
c	0.26	-	0.31
D	11.25	11.45	11.65
E	10.10	10.30	10.50
E1	7.30	7.50	7.70
e	1.27BSC		
L	0.70	-	1.00
L1	1.40BSC		
θ	0	-	8°

NOTICE

JSCJ reserves the right to make modifications, enhancements, improvements, corrections or other changes without further notice to any product herein. JSCJ does not assume any liability arising out of the application or use of any product described herein.