

Addendum for New QFN Package Migration

This addendum provides the changes to the 98A case outline numbers for products covered in this book. Case outlines were changed because of the migration from gold wire to copper wire in some packages. See the table below for the old (gold wire) package versus the new (copper wire) package.

To view the new drawing, go to Freescale.com and search on the new 98A package number for your device.

For more information about QFN package use, see EB806: *Electrical Connection Recommendations for the Exposed Pad on QFN and DFN Packages*.

Part Number	Package Description	Original (gold wire) package document number	Current (copper wire) package document number
MC68HC908JW32	48 QFN	98ARH99048A	98ASA00466D
MC9S08AC16			
MC9S908AC60			
MC9S08AC128			
MC9S08AW60			
MC9S08GB60A			
MC9S08GT16A			
MC9S08JM16			
MC9S08JM60			
MC9S08LL16			
MC9S08QE128			
MC9S08QE32			
MC9S08RG60			
MCF51CN128			
MC9RS08LA8	48 QFN	98ARL10606D	98ASA00466D
MC9S08GT16A	32 QFN	98ARH99035A	98ASA00473D
MC9S908QE32	32 QFN	98ARE10566D	98ASA00473D
MC9S908QE8	32 QFN	98ASA00071D	98ASA00736D
MC9S08JS16	24 QFN	98ARL10608D	98ASA00734D
MC9S08QB8			
MC9S08QG8	24 QFN	98ARL10605D	98ASA00474D
MC9S08SH8	24 QFN	98ARE10714D	98ASA00474D
MC9RS08KB12	24 QFN	98ASA00087D	98ASA00602D
MC9S08QG8	16 QFN	98ARE10614D	98ASA00671D
MC9RS08KB12	8 DFN	98ARL10557D	98ASA00672D
MC9S08QG8			
MC9RS08KA2	6 DFN	98ARL10602D	98ASA00735D

MC9S08AC128 8-Bit Microcontroller Data Sheet

MC9S08AC128

917A-03

840B-01

824D-02

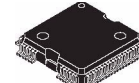

8-Bit HCS08 Central Processor Unit (CPU)

- 40-MHz HCS08 CPU (central processor unit)
- 20-MHz internal bus frequency
- HC08 instruction set with added BGND, CALL and RTC instructions
- Memory Management Unit to support paged memory.
- Linear Address Pointer to allow direct page data accesses of the entire memory map

Development Support

- Background debugging system
- Breakpoint capability to allow single breakpoint setting during in-circuit debugging (plus two more breakpoints in on-chip debug module)
- On-chip in-circuit emulator (ICE) Debug module containing three comparators and nine trigger modes. Eight deep FIFO for storing change-of-flow addresses and event-only data. Supports both tag and force breakpoints.

Memory Options

- Up to 128K FLASH — read/program/erase over full operating voltage and temperature
- Up to 8K Random-access memory (RAM)
- Security circuitry to prevent unauthorized access to RAM and FLASH contents

Clock Source Options

- Clock source options include crystal, resonator, external clock, or internally generated clock with precision NVM trimming using ICG module

System Protection

- Optional computer operating properly (COP) reset with option to run from independent internal clock source or bus clock
- CRC module to support fast cyclic redundancy checks on system memory
- Low-voltage detection with reset or interrupt
- Illegal opcode detection with reset
- Master reset pin and power-on reset (POR)

Power-Saving Modes

- Wait plus two stops

Peripherals

- **ADC** — 16-channel, 10-bit resolution, 2.5 μ s conversion time, automatic compare function, temperature sensor, internal bandgap reference channel
- **SCIx** — Two serial communications interface modules supporting LIN 2.0 Protocol and SAE J2602 protocols; Full duplex non-return to zero (NRZ); Master extended break generation; Slave extended break detection; Wakeup on active edge
- **SPIx** — One full and one master-only serial peripheral interface modules; Full-duplex or single-wire bidirectional; Double-buffered transmit and receive; Master or Slave mode; MSB-first or LSB-first shifting
- **IIC** — Inter-integrated circuit bus module; Up to 100 kbps with maximum bus loading; Multi-master operation; Programmable slave address; Interrupt driven byte-by-byte data transfer; supports broadcast mode and 10 bit addressing
- **TPMx** — One 2-channel and two 6-channel 16-bit timer/pulse-width modulator (TPM) modules: Selectable input capture, output compare, and edge-aligned PWM capability on each channel. Each timer module may be configured for buffered, centered PWM (CPWM) on all channels
- **KBI** — 8-pin keyboard interrupt module

Input/Output

- Up to 70 general-purpose input/output pins
- Software selectable pullups on input port pins
- Software selectable drive strength and slew rate control on ports when used as outputs

Package Options

- 80-pin low-profile quad flat package (LQFP)
- 64-pin quad flat package (QFP)
- 48-pin quad flat no-lead package (QFN)
- 44-pin low-profile quad flat package (LQFP)

This document contains information on a new product. Specifications and information herein are subject to change without notice.

Table of Contents

Chapter 1		3.9 Internal Clock Generation Module Characteristics . . .	24
Device Overview	3	3.9.1 ICG Frequency Specifications	25
1.1 MCU Block Diagram	3	3.10 AC Characteristics	27
Chapter 2		3.10.1 Control Timing	27
Pins and Connections	5	3.10.2 Timer/PWM (TPM) Module Timing	28
2.1 Device Pin Assignment	5	3.11 SPI Characteristics	30
Chapter 3		3.12 FLASH Specifications	33
Electrical Characteristics and Timing Specifications	11	3.13 EMC Performance	34
3.1 Introduction	11	3.13.1 Radiated Emissions	34
3.2 Parameter Classification	11	Chapter 4	
3.3 Absolute Maximum Ratings	11	Ordering Information and Mechanical Drawings	35
3.4 Thermal Characteristics	13	4.1 Ordering Information	35
3.5 ESD Protection and Latch-Up Immunity	14	4.2 Orderable Part Numbering System	35
3.6 DC Characteristics	14	4.3 Mechanical Drawings	35
3.7 Supply Current Characteristics	18	Chapter 5	
3.8 ADC Characteristics	21	Revision History	37

Related Documentation

MC9S08AC128 Series Reference Manual (MC9S08AC128RM)

contains extensive product information including modes of operation, memory, resets and interrupts, register definitions, port pins, CPU, and all peripheral module information.

For the latest version of the documentation, check our website at:

<http://www.freescale.com>

Chapter 1

Device Overview

The MC9S08AC128 is a member of the low-cost, high-performance HCS08 Family of 8-bit microcontroller units (MCUs). The MC9S08AC128 uses the enhanced HCS08 core.

1.1 MCU Block Diagram

The block diagram in [Figure 1-1](#) shows the structure of the MC9S08AC128 Series MCU.

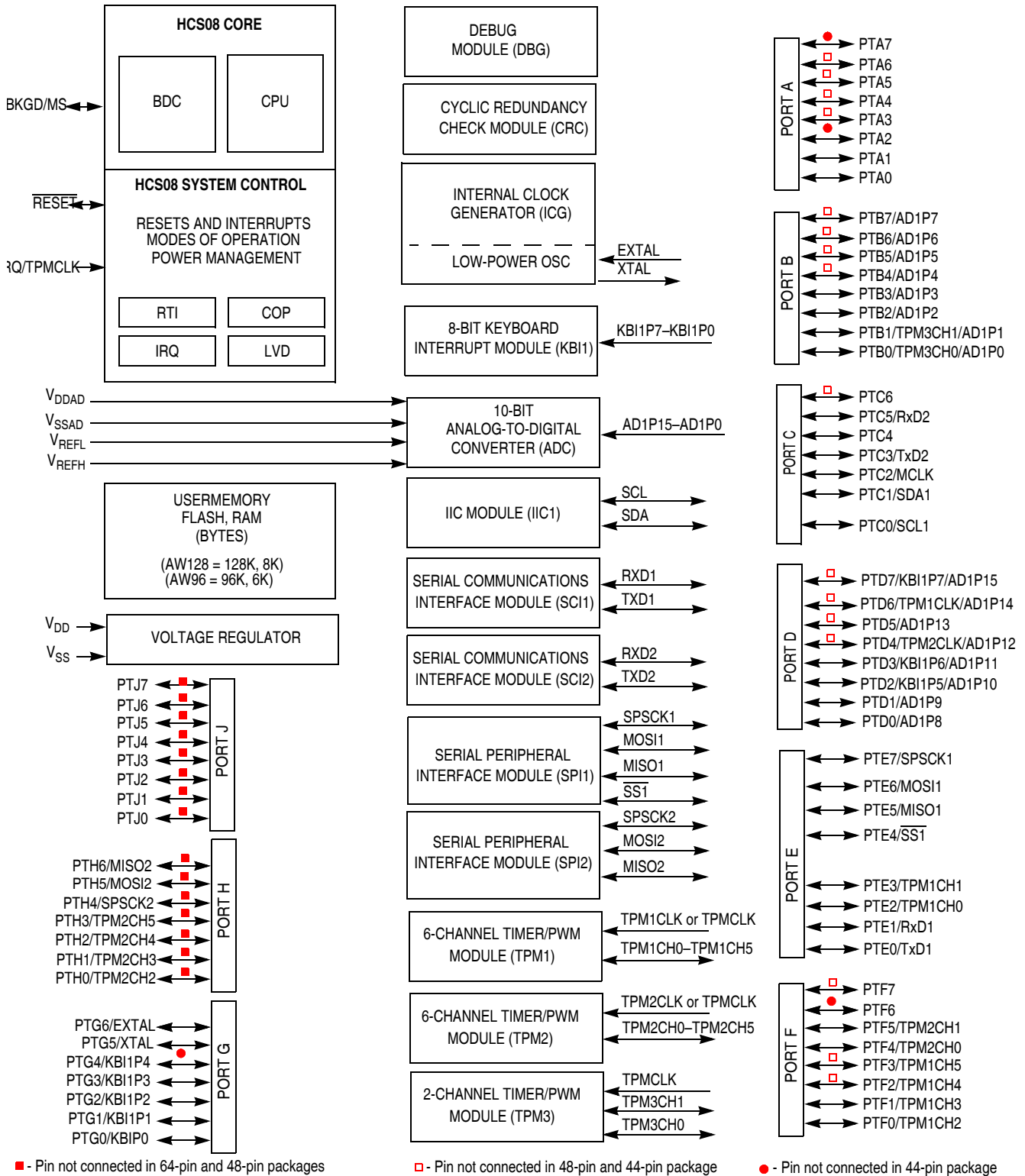

Figure 1-1. MC9S08AC128 Series Block Diagram

Chapter 2

Pins and Connections

This section describes signals that connect to package pins. It includes pinout diagrams, recommended system connections, and detailed discussions of signals.

2.1 Device Pin Assignment

Figure 2-1 shows the 80-pin LQFP package pin assignments for the MC9S08AC128 Series device.

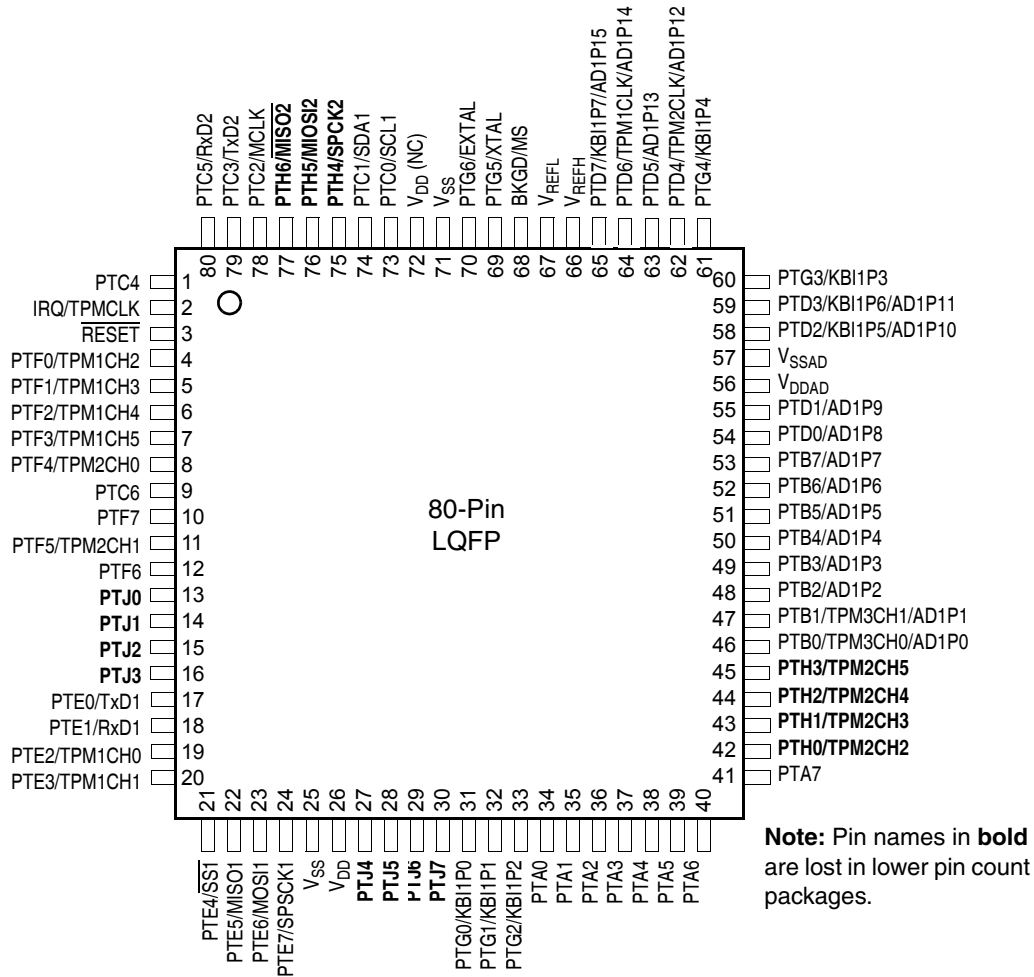

Figure 2-1. MC9S08AC128 Series in 80-Pin LQFP Package

Figure 2-2 shows the 64-pin package assignments for the MC9S08AC128 Series devices.

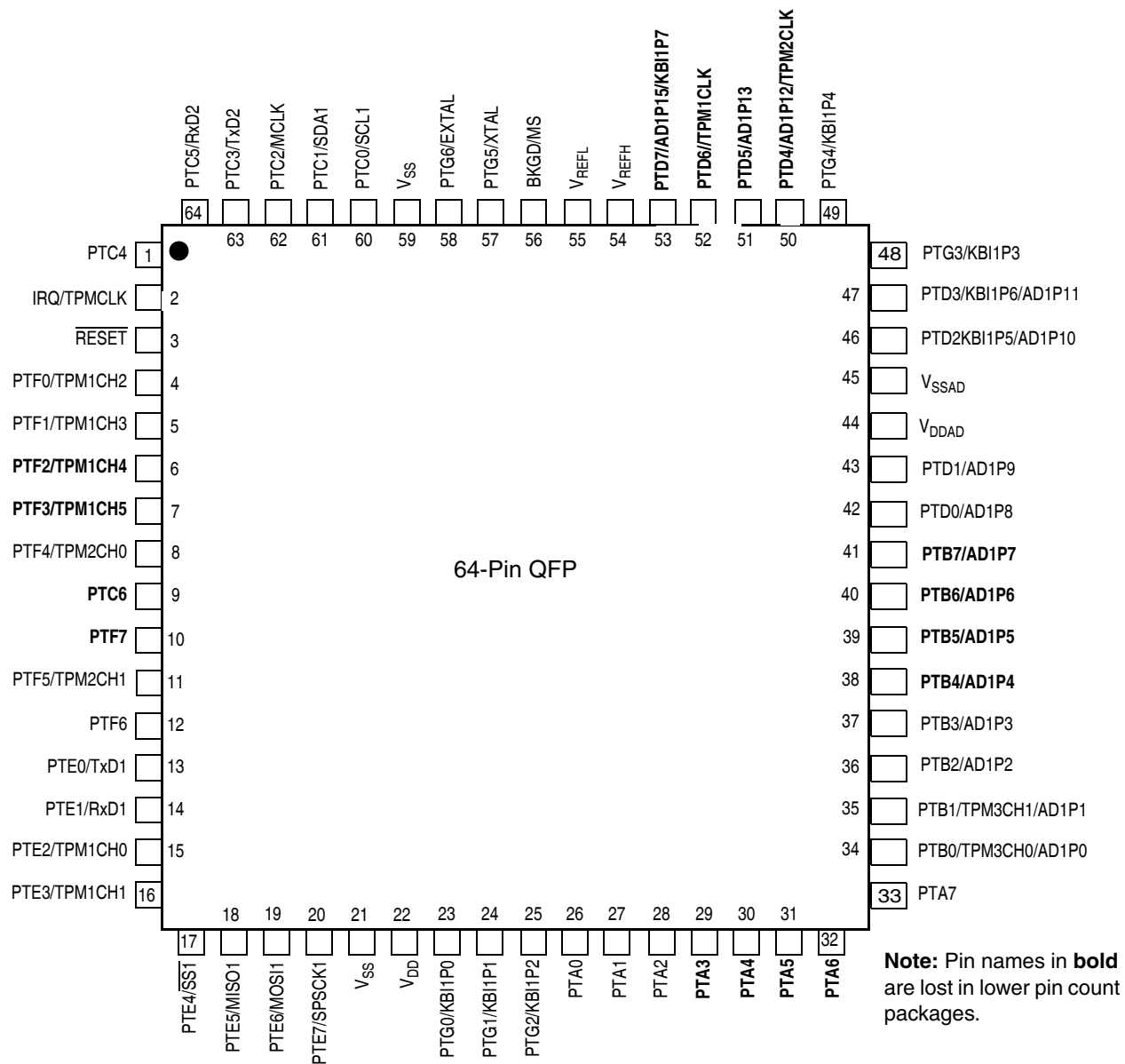
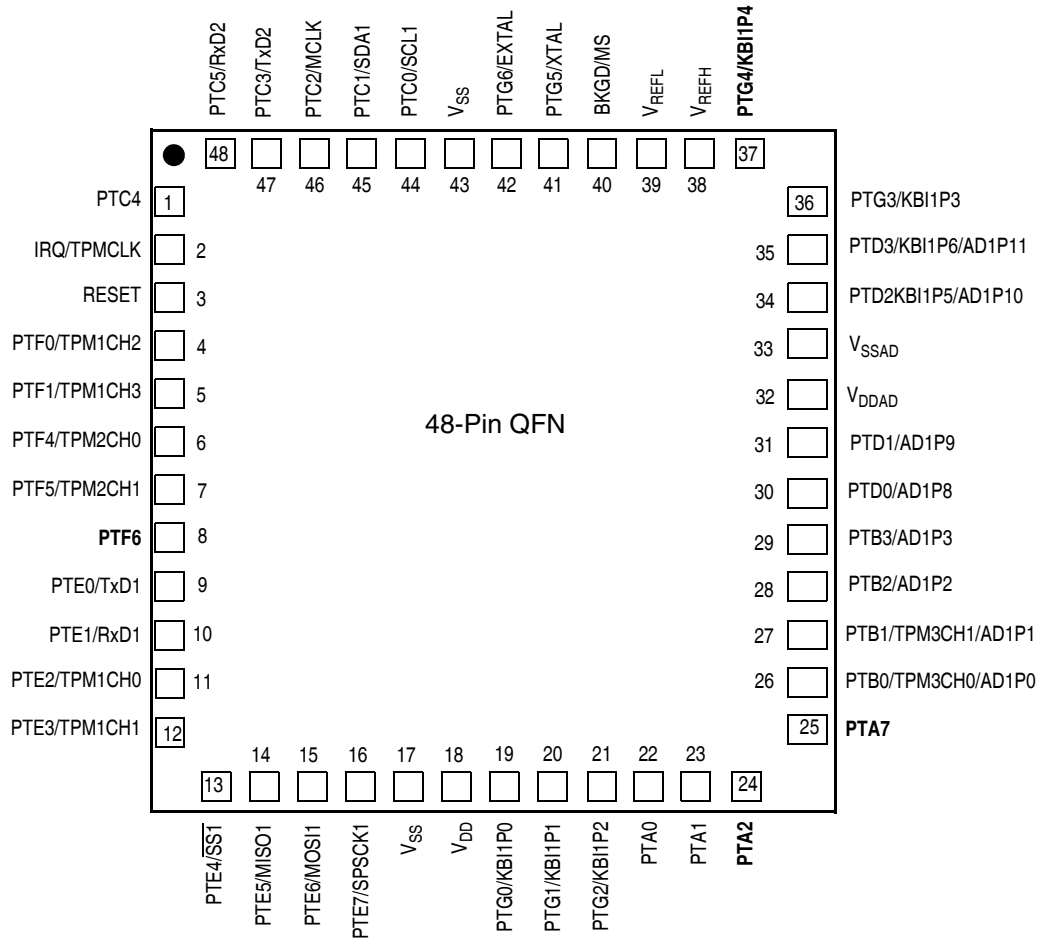

Figure 2-2. MC9S08AC128 Series in 64-Pin QFP Package

Figure 2-1 shows the 48-pin package assignments for the MC9S08AC128 Series devices.



Note: Pin names in bold are lost in lower pin count packages.

Figure 2-1. MC9S08AC128 Series in 48-Pin QFN Package

Figure 2-3 shows the 44-pin LQFP pin assignments for the MC9S08AC128 Series device.

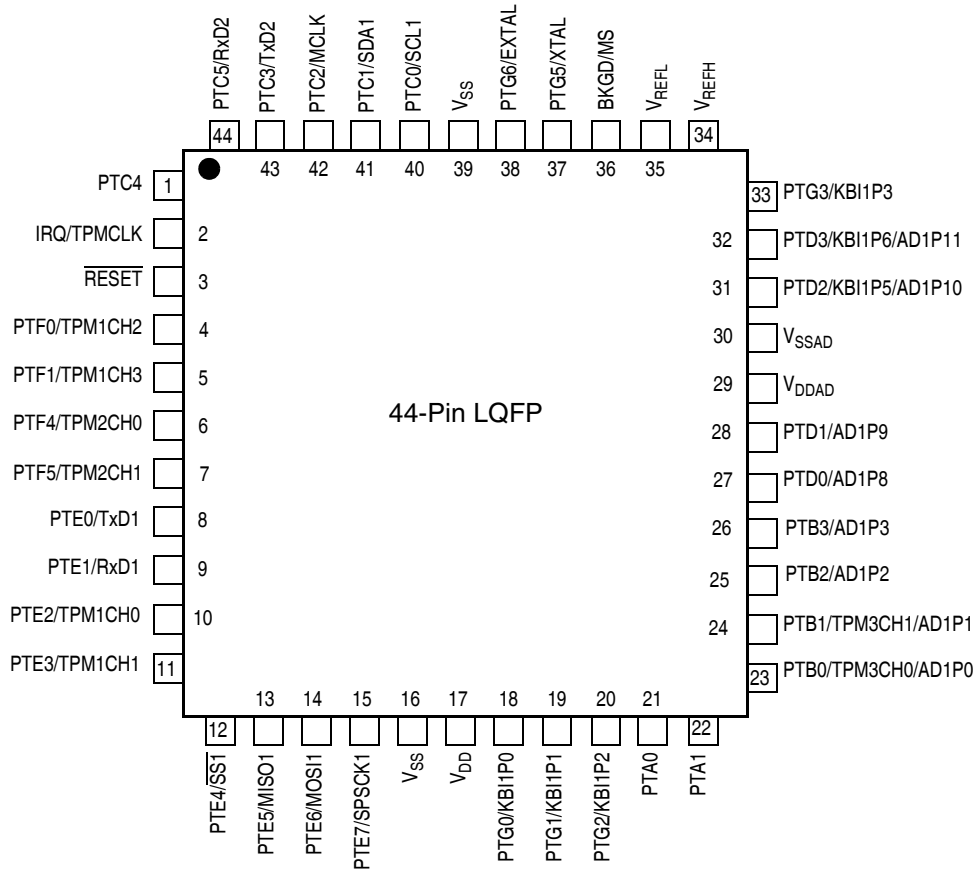

Figure 2-3. MC9S08AC128 Series in 44-Pin LQFP Package

Table 2-4. Pin Availability by Package Pin-Count

Pin Number				Lowest <--	Priority	--> Highest
80	64	48	44	Port Pin	Alt 1	Alt 2
1	1	1	1	PTC4		
2	2	2	2	IRQ	TPMCLK ¹	
3	3	3	3	RESET		
4	4	4	4	PTF0	TPM1CH2	
5	5	5	5	PTF1	TPM1CH3	
6	6	—	—	PTF2	TPM1CH4	
7	7	—	—	PTF3	TPM1CH5	
8	8	6	6	PTF4	TPM2CH0	
9	9	—	—	PTC6		
10	10	—	—	PTF7		
11	11	7	7	PTF5	TPM2CH1	
12	12	8	—	PTF6		

Table 2-4. Pin Availability by Package Pin-Count (continued)

Pin Number				Lowest <--	Priority	--> Highest
80	64	48	44	Port Pin	Alt 1	Alt 2
13	—	—	—	PTJ0		
14	—	—	—	PTJ1		
15	—	—	—	PTJ2		
16	—	—	—	PTJ3		
17	13	9	8	PTE0	TxD1	
18	14	10	9	PTE1	RxD1	
19	15	11	10	PTE2	TPM1CH0	
20	16	12	11	PTE3	TPM1CH1	
21	17	13	12	PTE4	$\overline{SS1}$	
22	18	14	13	PTE5	MISO1	
23	19	15	14	PTE6	MOSI1	
24	20	16	15	PTE7	SPSCK1	
25	21	17	16	V _{SS}		
26	22	18	17	V _{DD}		
27	—	—	—	PTJ4		
28	—	—	—	PTJ5		
29	—	—	—	PTJ6		
30	—	—	—	PTJ7		
31	23	19	18	PTG0	KBI1P0	
32	24	20	19	PTG1	KBI1P1	
33	25	21	20	PTG2	KBI1P2	
34	26	22	21	PTA0		
35	27	23	22	PTA1		
36	28	24	—	PTA2		
37	29	—	—	PTA3		
38	30	—	—	PTA4		
39	31	—	—	PTA5		
40	32	—	—	PTA6		
41	33	25	—	PTA7		
42	—	—	—	PTH0	TPM2CH2	
43	—	—	—	PTH1	TPM2CH3	
44	—	—	—	PTH2	TPM2CH4	
45	—	—	—	PTH3	TPM2CH5	
46	34	26	23	PTB0	TPM3CH0	AD1P0
47	35	27	24	PTB1	TPM3CH1	AD1P1
48	36	28	25	PTB2	AD1P2	
49	37	29	26	PTB3	AD1P3	
50	38	—	—	PTB4	AD1P4	
51	39	—	—	PTB5	AD1P5	
52	40	—	—	PTB6	AD1P6	
53	41	—	—	PTB7	AD1P7	

Table 2-4. Pin Availability by Package Pin-Count (continued)

Pin Number				Lowest <--	Priority	--> Highest
80	64	48	44	Port Pin	Alt 1	Alt 2
54	42	30	27	PTD0	AD1P8	
55	43	31	28	PTD1	AD1P9	
56	44	32	29	V _{DDAD}		
57	45	33	30	V _{SSAD}		
58	46	34	31	PTD2	KBI1P5	AD1P10
59	47	35	32	PTD3	KBI1P6	AD1P11
60	48	36	33	PTG3	KBI1P3	
61	49	37	—	PTG4	KBI1P4	
62	50	—	—	PTD4	TPM2CLK	AD1P12
63	51	—	—	PTD5	AD1P13	
64	52	—	—	PTD6	TPM1CLK	AD1P14
65	53	—	—	PTD7	KBI1P7	AD1P15
66	54	38	34	V _{REFH}		
67	55	39	35	V _{REFL}		
68	56	40	36	BKGD	MS	
69	57	41	37	PTG5	XTAL	
70	58	42	38	PTG6	EXTAL	
71	59	43	39	V _{SS}		
72	—	—	—	V _{DD(NC)}		
73	60	44	40	PTC0	SCL1	
74	61	45	41	PTC1	SDA1	
75	—	—	—	PTH4	SPSCK2	
76	—	—	—	PTH5	MOSI2	
77	—	—	—	PTH6	MISO2	
78	62	46	42	PTC2	MCLK	
79	63	47	43	PTC3	TxD2	
80	64	48	44	PTC5	RxD2	

¹ TPMCLK, TPM1CLK, and TPM2CLK options are configured via software; out of reset, TPM1CLK, TPM2CLK, and TPMCLK are available to TPM1, TPM2, and TPM3 respectively.

Chapter 3

Electrical Characteristics and Timing Specifications

3.1 Introduction

This section contains electrical and timing specifications.

3.2 Parameter Classification

The electrical parameters shown in this supplement are guaranteed by various methods. To give the customer a better understanding the following classification is used and the parameters are tagged accordingly in the tables where appropriate:

Table 3-1. Parameter Classifications

P	Those parameters are guaranteed during production testing on each individual device.
C	Those parameters are achieved by the design characterization by measuring a statistically relevant sample size across process variations.
T	Those parameters are achieved by design characterization on a small sample size from typical devices under typical conditions unless otherwise noted. All values shown in the typical column are within this category.
D	Those parameters are derived mainly from simulations.

NOTE

The classification is shown in the column labeled “C” in the parameter tables where appropriate.

3.3 Absolute Maximum Ratings

Absolute maximum ratings are stress ratings only, and functional operation at the maxima is not guaranteed. Stress beyond the limits specified in [Table 3-2](#) may affect device reliability or cause permanent damage to the device. For functional operating conditions, refer to the remaining tables in this section.

This device contains circuitry protecting against damage due to high static voltage or electrical fields; however, it is advised that normal precautions be taken to avoid application of any voltages higher than maximum-rated voltages to this high-impedance circuit. Reliability of operation is enhanced if unused inputs are tied to an appropriate logic voltage level (for instance, either V_{SS} or V_{DD}).

Table 3-2. Absolute Maximum Ratings

Rating	Symbol	Value	Unit
Supply voltage	V_{DD}	-0.3 to + 5.8	V
Input voltage	V_{In}	- 0.3 to $V_{DD} + 0.3$	V
Instantaneous maximum current Single pin limit (applies to all port pins) ^{1, 2, 3}	I_D	± 25	mA
Maximum current into V_{DD}	I_{DD}	120	mA
Storage temperature	T_{stg}	-55 to +150	°C

¹ Input must be current limited to the value specified. To determine the value of the required current-limiting resistor, calculate resistance values for positive (V_{DD}) and negative (V_{SS}) clamp voltages, then use the larger of the two resistance values.

² All functional non-supply pins are internally clamped to V_{SS} and V_{DD} .

³ Power supply must maintain regulation within operating V_{DD} range during instantaneous and operating maximum current conditions. If positive injection current ($V_{In} > V_{DD}$) is greater than I_{DD} , the injection current may flow out of V_{DD} and could result in external power supply going out of regulation. Ensure external V_{DD} load will shunt current greater than maximum injection current. This will be the greatest risk when the MCU is not consuming power. Examples are: if no system clock is present, or if the clock rate is very low which would reduce overall power consumption.

3.4 Thermal Characteristics

This section provides information about operating temperature range, power dissipation, and package thermal resistance. Power dissipation on I/O pins is usually small compared to the power dissipation in on-chip logic and it is user-determined rather than being controlled by the MCU design. In order to take $P_{I/O}$ into account in power calculations, determine the difference between actual pin voltage and V_{SS} or V_{DD} and multiply by the pin current for each I/O pin. Except in cases of unusually high pin current (heavy loads), the difference between pin voltage and V_{SS} or V_{DD} will be very small.

Table 3-3. Thermal Characteristics

Rating	Symbol	Value	Unit	
Operating temperature range (packaged)	T_A	T_L to T_H -40 to 125	°C	
Maximum junction temperature	T_J	150	°C	
Thermal resistance ^{1,2,3,4}				
80-pin LQFP				
1s		61		
2s2p		47		
64-pin QFP				
1s	θ_{JA}	57	°C/W	
2s2p		43		
48-pin QFN				
1s		81		
2s2p		28		
44-pin LQFP				
1s		73		
2s2p		56		

¹ Junction temperature is a function of die size, on-chip power dissipation, package thermal resistance, mounting site (board) temperature, ambient temperature, air flow, power dissipation of other components on the board, and board thermal resistance.

² Junction to Ambient Natural Convection

³ 1s - Single Layer Board, one signal layer

⁴ 2s2p - Four Layer Board, 2 signal and 2 power layers

The average chip-junction temperature (T_J) in °C can be obtained from:

$$T_J = T_A + (P_D \times \theta_{JA}) \quad \text{Eqn. 3-1}$$

where:

T_A = Ambient temperature, °C

θ_{JA} = Package thermal resistance, junction-to-ambient, °C/W

$P_D = P_{int} + P_{I/O}$

$P_{int} = I_{DD} \times V_{DD}$, Watts — chip internal power

$P_{I/O}$ = Power dissipation on input and output pins — user determined

For most applications, $P_{I/O} \ll P_{int}$ and can be neglected. An approximate relationship between P_D and T_J (if $P_{I/O}$ is neglected) is:

$$P_D = K \div (T_J + 273^\circ\text{C}) \quad \text{Eqn. 3-2}$$

Solving equations 1 and 2 for K gives:

$$K = P_D \times (T_A + 273^\circ\text{C}) + \theta_{JA} \times (P_D)^2 \quad \text{Eqn. 3-3}$$

where K is a constant pertaining to the particular part. K can be determined from equation 3 by measuring P_D (at equilibrium) for a known T_A . Using this value of K, the values of P_D and T_J can be obtained by solving equations 1 and 2 iteratively for any value of T_A .

3.5 ESD Protection and Latch-Up Immunity

Although damage from electrostatic discharge (ESD) is much less common on these devices than on early CMOS circuits, normal handling precautions should be used to avoid exposure to static discharge. Qualification tests are performed to ensure that these devices can withstand exposure to reasonable levels of static without suffering any permanent damage.

All ESD testing is in conformity with AEC-Q100 Stress Test Qualification for Automotive Grade Integrated Circuits and JEDEC Standard for Non-Automotive Grade Integrated Circuits. During the device qualification ESD stresses were performed for the Human Body Model (HBM), the Machine Model (MM) and the Charge Device Model (CDM).

A device is defined as a failure if after exposure to ESD pulses the device no longer meets the device specification. Complete DC parametric and functional testing is performed per the applicable device specification at room temperature followed by hot temperature, unless specified otherwise in the device specification.

Table 3-4. ESD and Latch-up Test Conditions

Model	Description	Symbol	Value	Unit
Human Body	Series Resistance	R1	1500	Ω
	Storage Capacitance	C	100	pF
	Number of Pulse per pin	–	3	
Machine	Series Resistance	R1	0	Ω
	Storage Capacitance	C	200	pF
	Number of Pulse per pin	–	3	
Latch-up	Minimum input voltage limit		– 2.5	V
	Maximum input voltage limit		7.5	V

Table 3-5. ESD and Latch-Up Protection Characteristics

Num	C	Rating	Symbol	Min	Max	Unit
1	C	Human Body Model (HBM)	V_{HBM}	± 2000	–	V
2	C	Machine Model (MM)	V_{MM}	± 200	–	V
3	C	Charge Device Model (CDM)	V_{CDM}	± 500	–	V
4	C	Latch-up Current at $T_A = 125^\circ\text{C}$	I_{LAT}	± 100	–	mA

3.6 DC Characteristics

This section includes information about power supply requirements, I/O pin characteristics, and power supply current in various operating modes.

Table 3-6. DC Characteristics

Num	C	Parameter	Symbol	Min	Typ ¹	Max	Unit	
1	—	Operating Voltage	V_{DD}	2.7	—	5.5	V	
2	P	Output high voltage — Low Drive (PTxDSn = 0) 5 V, $I_{Load} = -2$ mA 3 V, $I_{Load} = -0.6$ mA 5 V, $I_{Load} = -0.4$ mA 3 V, $I_{Load} = -0.24$ mA	V_{OH}	$V_{DD} - 1.5$	—	—	V	
	P	Output high voltage — High Drive (PTxDSn = 1) 5 V, $I_{Load} = -10$ mA 3 V, $I_{Load} = -3$ mA 5 V, $I_{Load} = -2$ mA 3 V, $I_{Load} = -0.4$ mA		$V_{DD} - 1.5$	—	—		
3	P	Output low voltage — Low Drive (PTxDSn = 0) 5 V, $I_{Load} = 2$ mA 3 V, $I_{Load} = 0.6$ mA 5 V, $I_{Load} = 0.4$ mA 3 V, $I_{Load} = 0.24$ mA	V_{OL}	—	—	1.5	V	
	P	Output low voltage — High Drive (PTxDSn = 1) 5 V, $I_{Load} = 10$ mA 3 V, $I_{Load} = 3$ mA 5 V, $I_{Load} = 2$ mA 3 V, $I_{Load} = 0.4$ mA		—	—	1.5		
4	P	Output high current — Max total I_{OH} for all ports 5V 3V	I_{OHT}	— —	— —	100 60	mA	
5	P	Output low current — Max total I_{OL} for all ports 5V 3V	I_{OLT}	— —	— —	100 60	mA	
6	P	Input high voltage; all digital inputs	V_{IH}	$2.7v \leq V_{DD} < 4.5v$	—	—	V	
				$4.5v \leq V_{DD} \leq 5.5v$	—	—		
7	P	Input low voltage; all digital inputs	V_{IL}	—	—	$0.35 \times V_{DD}$		
8	P	Input hysteresis; all digital inputs	V_{hys}	$0.06 \times V_{DD}$			mV	
9	P	Input leakage current; input only pins ²	$ I_{In} $	—	0.1	1	μA	
10	P	High Impedance (off-state) leakage current ²	$ I_{OZ} $	—	0.1	1	μA	
11	P	Internal pullup resistors ³	R_{PU}	20	45	65	k Ω	
12	P	Internal pulldown resistors ⁴	R_{PD}	20	45	65	k Ω	
13	C	Input Capacitance; all non-supply pins	C_{In}	—	—	8	pF	
14	D	RAM retention voltage	V_{RAM}	—	0.6	1.0	V	
15	P	POR rearm voltage	V_{POR}	0.9	1.4	2.0	V	
16	D	POR rearm time	t_{POR}	10	—	—	μs	
17	P	Low-voltage detection threshold — high range	V_{LVDH}	V_{DD} falling	4.2	4.3	4.4	V
				V_{DD} rising	4.3	4.4	4.5	
18	P	Low-voltage detection threshold — low range	V_{LVDL}	V_{DD} falling	2.48	2.56	2.64	V
				V_{DD} rising	2.54	2.62	2.7	

Table 3-6. DC Characteristics (continued)

Num	C	Parameter	Symbol	Min	Typ ¹	Max	Unit
19	P	Low-voltage warning threshold — high range V_{DD} falling V_{DD} rising	V_{LVWH}	4.2 4.3	4.3 4.4	4.4 4.5	V
20	P	Low-voltage warning threshold — low range V_{DD} falling V_{DD} rising	V_{LVWL}	2.48 2.54	2.56 2.62	2.64 2.7	V
21	P	Low-voltage inhibit reset/recover hysteresis 5V 3V	V_{hys}	— —	100 60	— —	mV
22	P	Bandgap Voltage Reference ⁵	V_{BG}	1.170	1.200	1.230	V

¹ Typical values are based on characterization data at 25°C unless otherwise stated.

² Measured with $V_{In} = V_{DD}$ or V_{SS} .

³ Measured with $V_{In} = V_{SS}$.

⁴ Measured with $V_{In} = V_{DD}$.

⁵ Factory trimmed at $V_{DD} = 3.0$ V, Temperature = 25 °C.

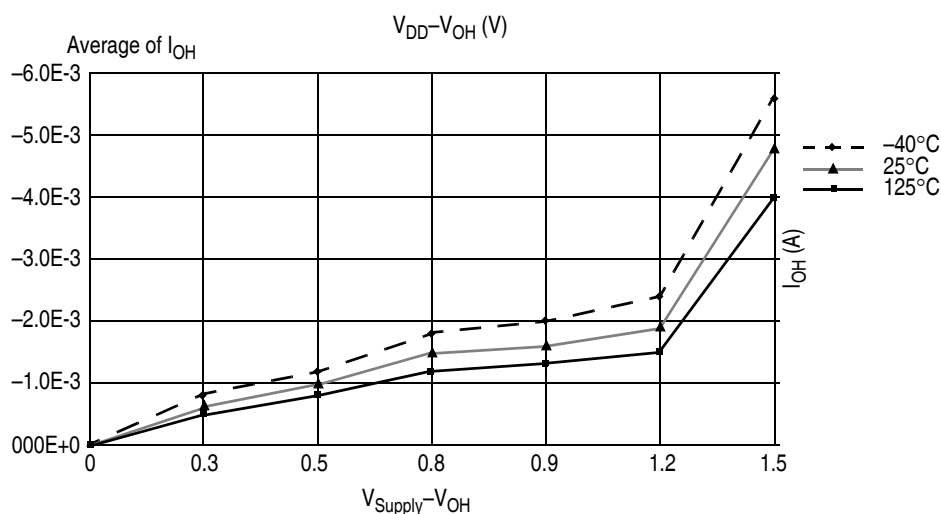

Figure 3-1. Typical I_{OH} (Low Drive) vs $V_{DD} - V_{OH}$ at $V_{DD} = 3$ V

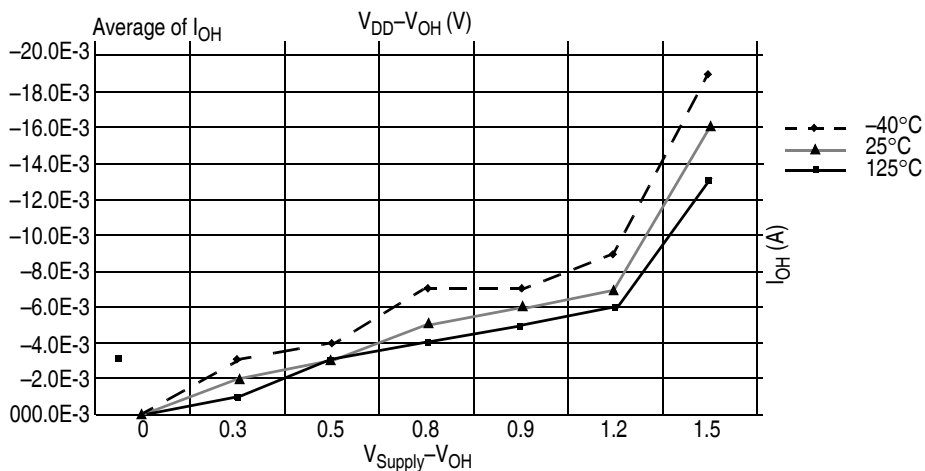

Figure 3-2. Typical I_{OH} (High Drive) vs $V_{DD}-V_{OH}$ at $V_{DD} = 3\text{ V}$

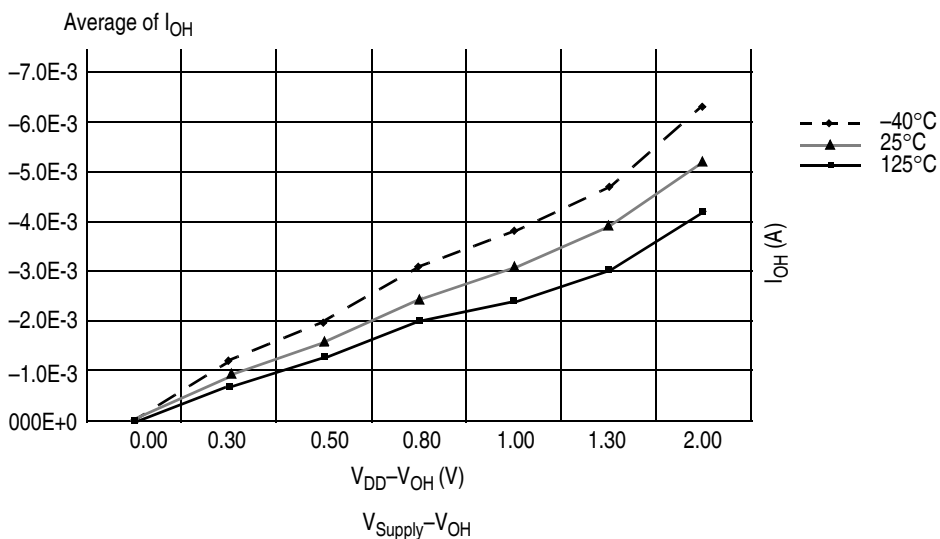

Figure 3-3. Typical I_{OH} (Low Drive) vs $V_{DD}-V_{OH}$ at $V_{DD} = 5\text{ V}$

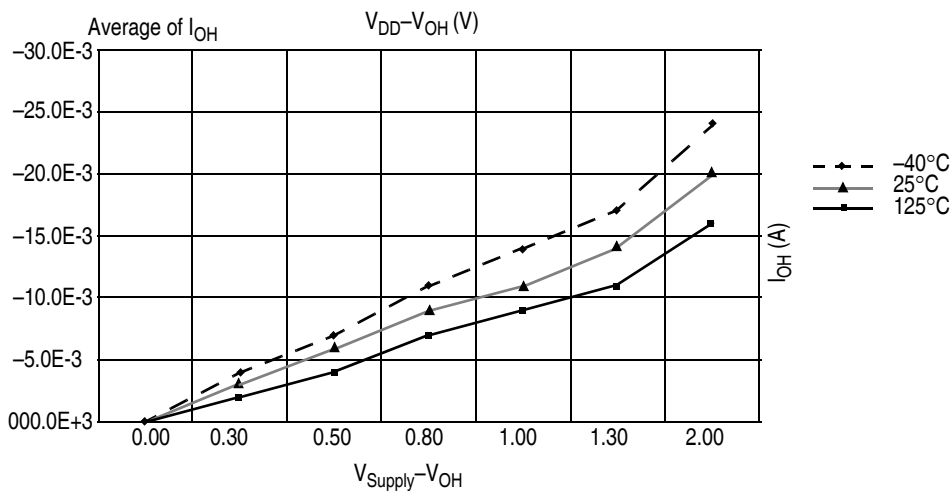

Figure 3-4. Typical I_{OH} (High Drive) vs $V_{DD}-V_{OH}$ at $V_{DD} = 5\text{ V}$

3.7 Supply Current Characteristics

Table 3-7. Supply Current Characteristics

Num	C	Parameter	Symbol	V _{DD} (V)	Typ ¹	Max	Unit	Temp (°C)
1	C	Run supply current ² measured at (CPU clock = 2 MHz, f _{Bus} = 1 MHz)	R _I DD	5	1.1	1.4 ³	mA	-40 to 125°C
				3	1.0	1.2		
2	C	Run supply current ⁴ measured at (CPU clock = 16 MHz, f _{Bus} = 8 MHz)	R _I DD	5	6.7	8.0 ⁵	mA	-40 to 125°C
				3	6	7.5		
3	C	Stop2 mode supply current	S2 _I DD	5	1.0	25 160	μA	-40 to 85°C -40 to 125°C
				3	0.8	23 150	μA	-40 to 85°C -40 to 125°C
4	C	Stop3 mode supply current	S3 _I DD	5	1.2	27 180 ³	μA	-40 to 85°C -40 to 125°C
				3	1.0	25 170	μA	-40 to 85°C -40 to 125°C
5	C	RTI adder to stop2 or stop3 ⁶	S23 _I DDRTI	5	300	500 500	nA	-40 to 85°C -40 to 125°C
				3	300	500 500	nA	-40 to 85°C -40 to 125°C
6	C	LVD adder to stop3 (LVDE = LVDSE = 1)	S3 _I DDLVD	5	110	180 180	μA	-40 to 85°C -40 to 125°C
				3	90	160 160	μA	-40 to 85°C -40 to 125°C
7	C	Adder to stop3 for oscillator enabled ⁷ (OSCSTEN = 1)	S3 _I DDOSC	5,3	5	8 8	μA μA	-40 to 85°C -40 to 125°C

¹ Typical values are based on characterization data at 25°C unless otherwise stated. See [Figure 3-5](#) through [Figure 3-7](#) for typical curves across voltage/temperature.

² All modules except ADC active, ICG configured for FBE, and does not include any dc loads on port pins

³ Every unit tested to this parameter. All other values in the Max column are guaranteed by characterization.

⁴ All modules except ADC active, ICG configured for FBE, and does not include any dc loads on port pins

⁵ Every unit tested to this parameter. All other values in the Max column are guaranteed by characterization.

⁶ Most customers are expected to find that auto-wakeup from stop2 or stop3 can be used instead of the higher current wait mode. Wait mode typical is 560 μA at 3 V with f_{Bus} = 1 MHz.

⁷ Values given under the following conditions: low range operation (RANGE = 0) with a 32.768kHz crystal, low power mode (HGO = 0), clock monitor disabled (LOCD = 1).

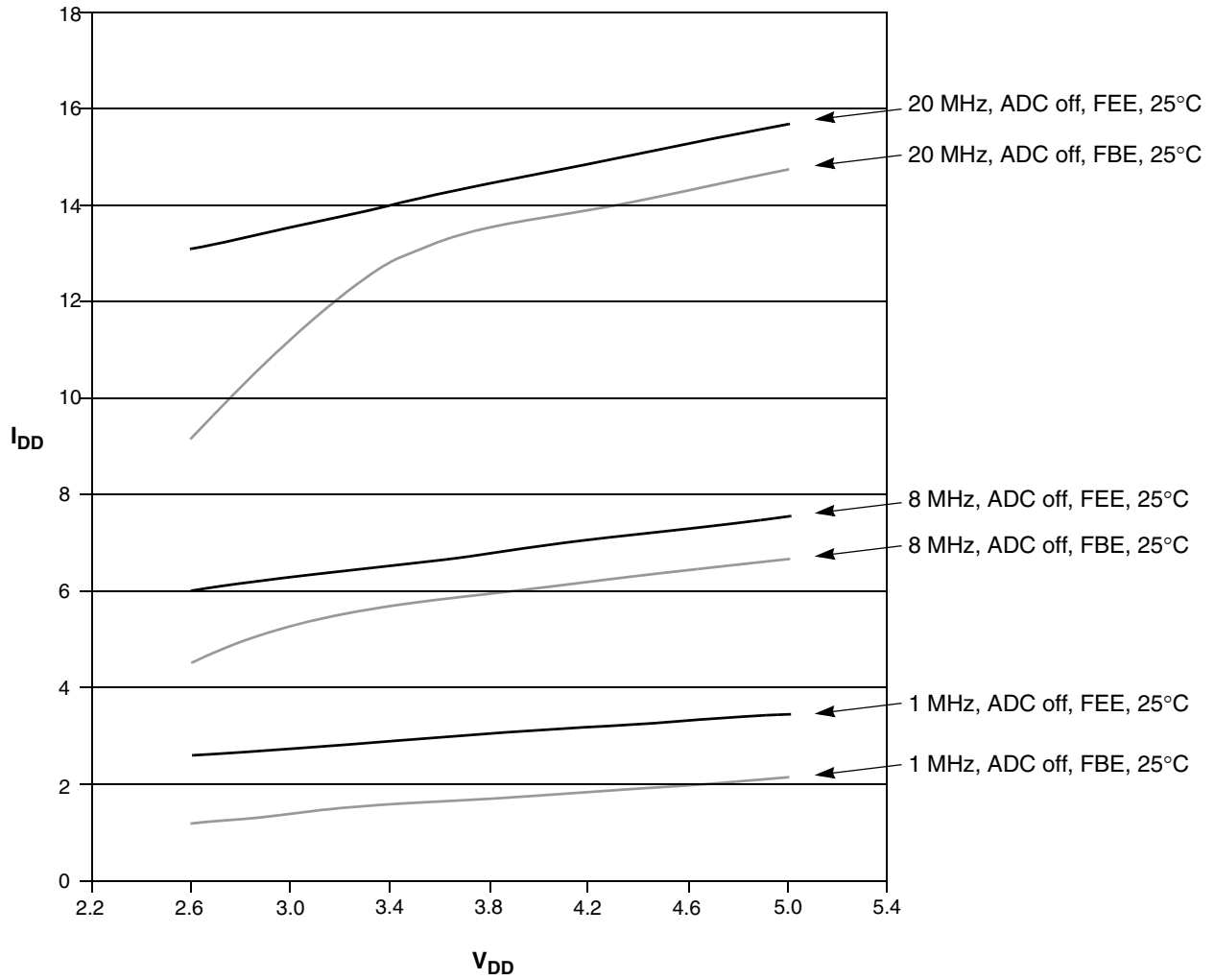

Note: External clock is square wave supplied by function generator. For FEE mode, external reference frequency is 4 MHz

Figure 3-5. Typical Run I_{DD} for FBE and FEE Modes, I_{DD} vs. V_{DD}

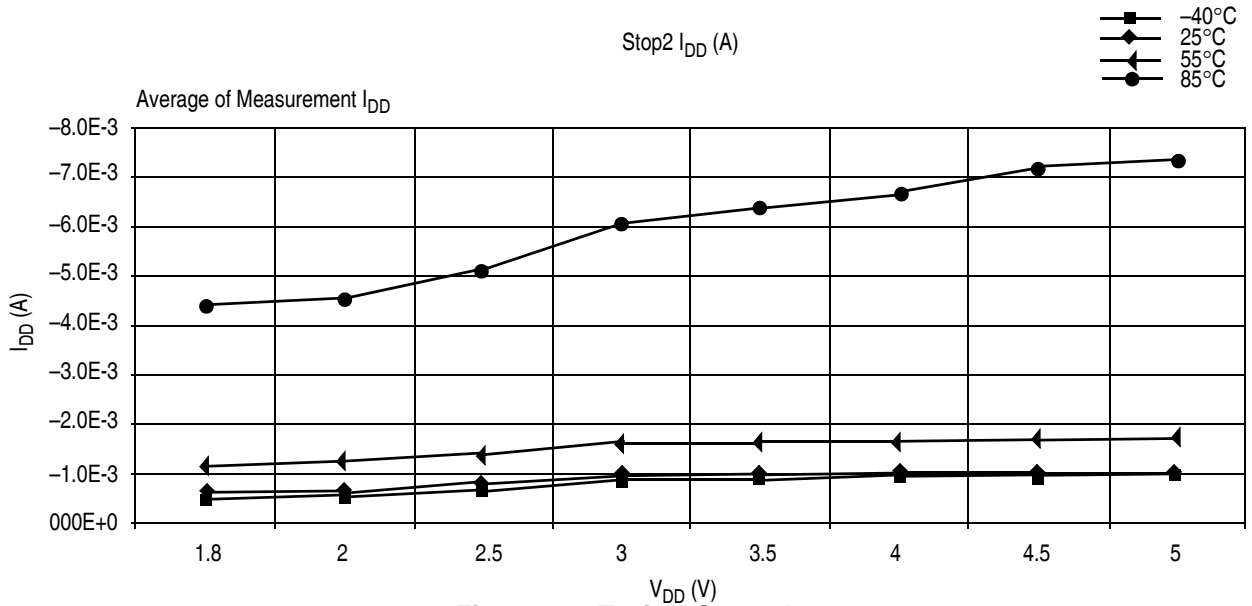

Figure 3-6. Typical Stop2 I_{DD}

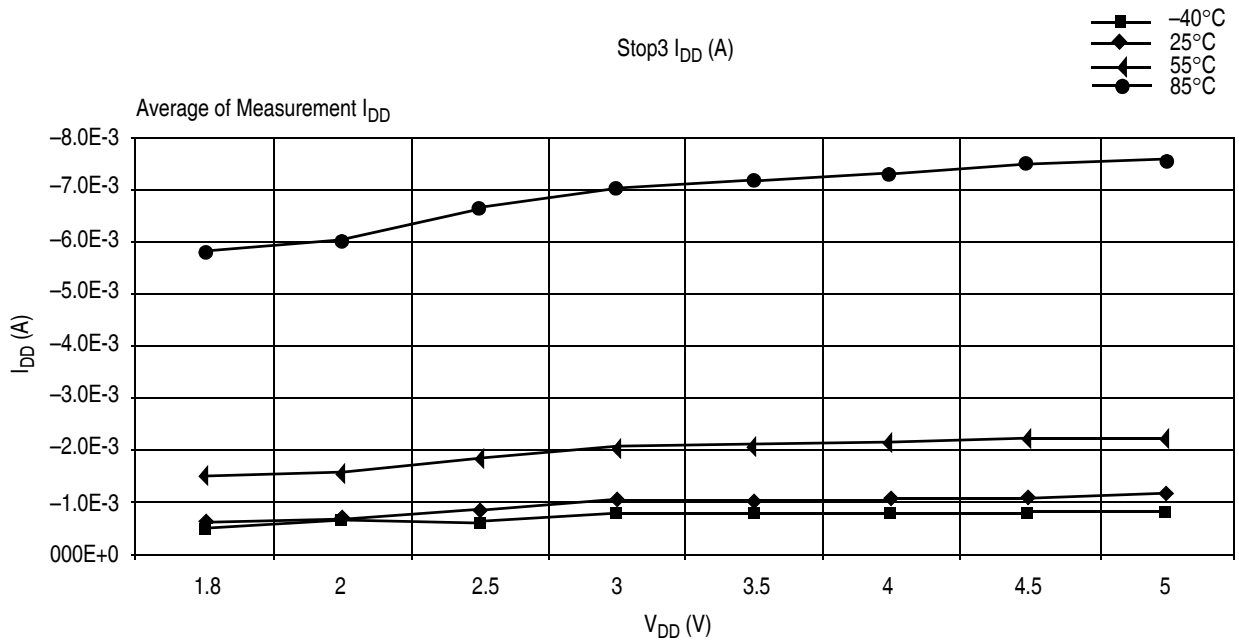

Figure 3-7. Typical Stop3 I_{DD}

3.8 ADC Characteristics

Table 3-8. 5 Volt 10-bit ADC Operating Conditions

Characteristic	Conditions	Symb	Min	Typ ¹	Max	Unit
Supply voltage	Absolute	V_{DDAD}	2.7	—	5.5	V
	Delta to V_{DD} ($V_{DD}-V_{DDAD}$) ²	ΔV_{DDAD}	-100	0	+100	mV
Ground voltage	Delta to V_{SS} ($V_{SS}-V_{SSAD}$) ²	ΔV_{SSAD}	-100	0	+100	mV
Ref voltage high		V_{REFH}	2.7	V_{DDAD}	V_{DDAD}	V
Ref voltage low		V_{REFL}	V_{SSAD}	V_{SSAD}	V_{SSAD}	V
Supply current	Stop, reset, module off	I_{DDAD}	—	0.011	1	μ A
Input voltage		V_{ADIN}	V_{REFL}	—	V_{REFH}	V
Input capacitance		C_{ADIN}	—	4.5	5.5	pF
Input resistance		R_{ADIN}	—	3	5	k Ω
Analog source resistance External to MCU	10-bit mode $f_{ADCK} > 4$ MHz $f_{ADCK} < 4$ MHz	R_{AS}	—	—	5	k Ω
	8-bit mode (all valid f_{ADCK})		—	—	10	
ADC conversion clock frequency	High speed (ADLPC = 0)	f_{ADCK}	0.4	—	8.0	MHz
	Low power (ADLPC = 1)		0.4	—	4.0	
Temp Sensor Slope	-40°C to 25°C	m	—	3.266	—	mV/ $^{\circ}$ C
	25°C to 125°C		—	3.638	—	
Temp Sensor Voltage	25°C	V_{TEMP25}	—	1.396	—	V

¹ Typical values assume $V_{DDAD} = 5.0$ V, Temp = 25°C, $f_{ADCK} = 1.0$ MHz unless otherwise stated. Typical values are for reference only and are not tested in production.

² dc potential difference.

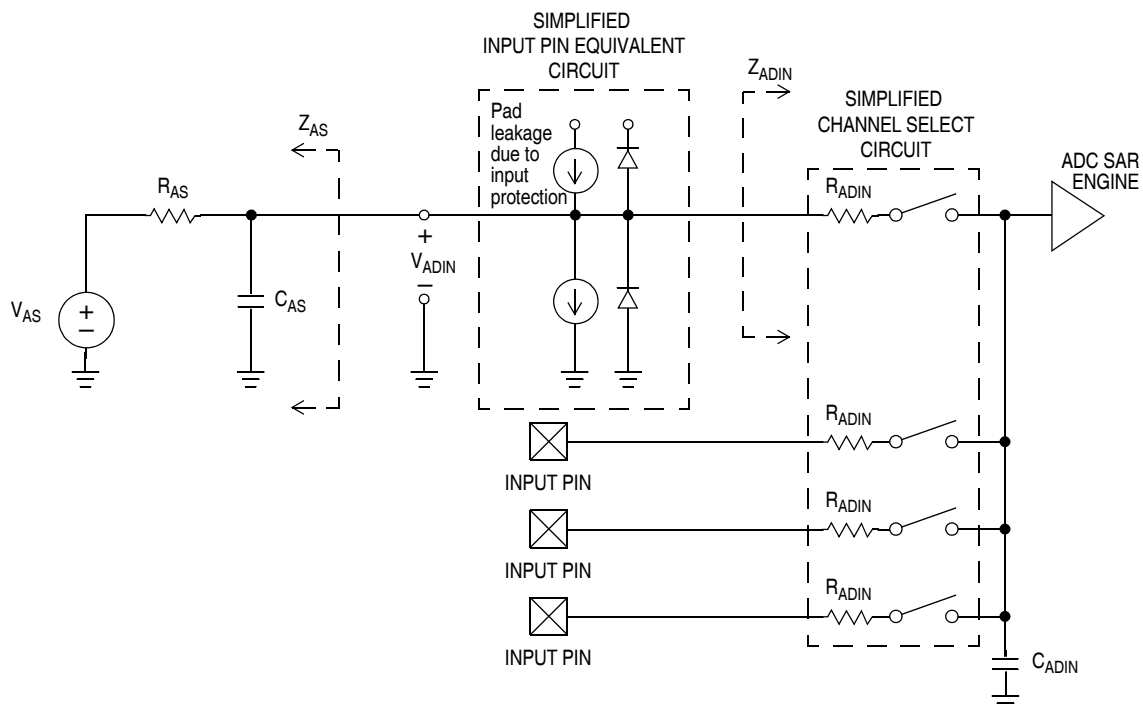

Figure 3-8. ADC Input Impedance Equivalency Diagram

Table 3-9. 5 Volt 10-bit ADC Characteristics ($V_{REFH} = V_{DDAD}$, $V_{REFL} = V_{SSAD}$)

Characteristic	Conditions	C	Symb	Min	Typ ¹	Max	Unit
Supply current ADLPC = 1 ADLSMP = 1 ADCO = 1		T	I_{DDAD}	—	133	—	μA
Supply current ADLPC = 1 ADLSMP = 0 ADCO = 1		T	I_{DDAD}	—	218	—	μA
Supply current ADLPC = 0 ADLSMP = 1 ADCO = 1		T	I_{DDAD}	—	327	—	μA
Supply current ADLPC = 0 ADLSMP = 0 ADCO = 1		T	I_{DDAD}	—	582	—	μA
	$V_{DDAD} \leq 5.5 \text{ V}$	P		—	—	1	mA
ADC asynchronous clock source $t_{ADACK} = 1/f_{ADACK}$	High speed (ADLPC = 0)	P	f_{ADACK}	2	3.3	5	MHz
	Low power (ADLPC = 1)			1.25	2	3.3	
Conversion time (Including sample time)	Short sample (ADLSMP = 0)	P	t_{ADC}	—	20	—	ADCK cycles
	Long sample (ADLSMP = 1)			—	40	—	
Sample time	Short sample (ADLSMP = 0)	P	t_{ADS}	—	3.5	—	ADCK cycles
	Long sample (ADLSMP = 1)			—	23.5	—	
Total unadjusted error Includes quantization	10-bit mode	P	E_{TUE}	—	± 1	± 2.5	LSB^2
	8-bit mode			—	± 0.5	± 1.0	
Differential non-linearity	10-bit mode	P	DNL	—	± 0.5	± 1.0	LSB^2
	8-bit mode			—	± 0.3	± 0.5	
	Monotonicity and no-missing-codes guaranteed						
Integral non-linearity	10-bit mode	C	INL	—	± 0.5	± 1.0	LSB^2
	8-bit mode			—	± 0.3	± 0.5	
Zero-scale error $V_{ADIN} = V_{SSA}$	10-bit mode	P	E_{ZS}	—	± 0.5	± 1.5	LSB^2
	8-bit mode			—	± 0.5	± 0.5	
Full-scale error $V_{ADIN} = V_{DDA}$	10-bit mode	P	E_{FS}	—	± 0.5	± 1.5	LSB^2
	8-bit mode			—	± 0.5	± 0.5	
Quantization error	10-bit mode	D	E_Q	—	—	± 0.5	LSB^2
	8-bit mode			—	—	± 0.5	

Table 3-9. 5 Volt 10-bit ADC Characteristics ($V_{REFH} = V_{DDAD}$, $V_{REFL} = V_{SSAD}$)

Characteristic	Conditions	C	Symb	Min	Typ ¹	Max	Unit
Input leakage error Pad leakage ³ * R _{AS}	10-bit mode	D	E _{IL}	—	±0.2	±2.5	LSB ²
	8-bit mode			—	±0.1	±1	

¹ Typical values assume $V_{DDAD} = 5.0V$, Temp = 25°C, $f_{ADCK} = 1.0$ MHz unless otherwise stated. Typical values are for reference only and are not tested in production.

² 1 LSB = $(V_{REFH} - V_{REFL})/2^N$

³ Based on input pad leakage current. Refer to pad electricals.

3.9 Internal Clock Generation Module Characteristics

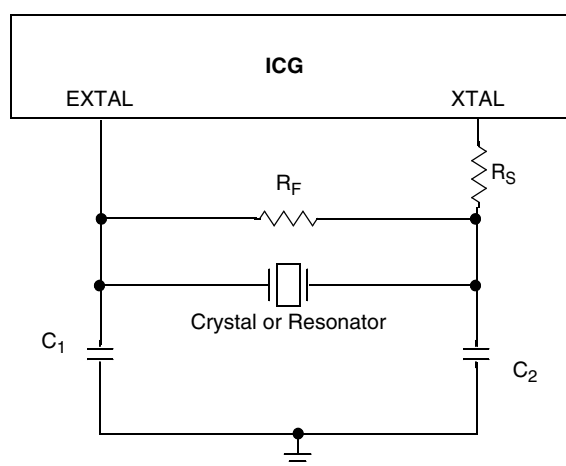
Table 3-10. ICG DC Electrical Specifications (Temperature Range = -40 to 125°C Ambient)

Characteristic	Symbol	Min	Typ ¹	Max	Unit
Load capacitors	C_1 C_2	See Note ²			
Feedback resistor	R_F		10		MΩ
Low range (32k to 100 kHz) High range (1M – 16 MHz)			1		MΩ
Series resistor	R_S				kΩ
Low range					
Low Gain (HGO = 0)		—	0	—	
High Gain (HGO = 1)		—	100	—	
High range					
Low Gain (HGO = 0)		—	0	—	
High Gain (HGO = 1)					
≥ 8 MHz	—	0	—		
4 MHz	—	10	—		
1 MHz	—	20	—		

¹ Typical values are based on characterization data at $V_{DD} = 5.0V$, 25°C or is typical recommended value.

² See crystal or resonator manufacturer's recommendation.

3.9.1 ICG Frequency Specifications

Table 3-11. ICG Frequency Specifications

 ($V_{DDA} = V_{DDA}(\text{min})$ to $V_{DDA}(\text{max})$, Temperature Range = -40 to 125°C Ambient)

Num	C	Characteristic	Symbol	Min	Typ ¹	Max	Unit	
1		Oscillator crystal or resonator (REFS = 1) (Fundamental mode crystal or ceramic resonator)						
		Low range	f _{lo}	32	—	100	kHz	
		High range						
		High Gain, FBE (HGO = 1, CLKS = 10)	f _{hi_byp}	1	—	16	MHz	
		High Gain, FEE (HGO = 1, CLKS = 11)	f _{hi_eng}	2	—	10	MHz	
		Low Power, FBE (HGO = 0, CLKS = 10)	f _{lp_byp}	1	—	8	MHz	
Low Power, FEE (HGO = 0, CLKS = 11)	f _{lp_eng}	2	—	8	MHz			
2		Input clock frequency (CLKS = 11, REFS = 0)						
		Low range	f _{lo}	32	—	100	kHz	
		High range	f _{hi_eng}	2	—	10	MHz	
3		Input clock frequency (CLKS = 10, REFS = 0)	f _{Extal}	0	—	40	MHz	
4		Internal reference frequency (untrimmed)	f _{ICGIRCLK}	182.25	243	303.75	kHz	
5		Duty cycle of input clock (REFS = 0)	t _{dc}	40	—	60	%	
6		Output clock ICGOUT frequency	f _{ICGOUT}	f _{Extal (min)}	—	f _{Extal (max)}	MHz	
		CLKS = 10, REFS = 0 All other cases		f _{lo (min)}	—	f _{ICGDCLKmax (max)}		
7		Minimum DCO clock (ICGDCLK) frequency	f _{ICGDCLKmin}	3	—		MHz	
8		Maximum DCO clock (ICGDCLK) frequency	f _{ICGDCLKmax}		—	40	MHz	
9		Self-clock mode (ICGOUT) frequency ²	f _{Self}	f _{ICGDCLKmin}		f _{ICGDCLKmax}	MHz	
10		Self-clock mode reset (ICGOUT) frequency	f _{Self_reset}	5.5	8	10.5	MHz	
11		Loss of reference frequency ³						
		Low range	f _{LOR}	5		25	kHz	
High range		50		500				
12		Loss of DCO frequency ⁴	f _{LOD}	0.5		1.5	MHz	
13		Crystal start-up time ^{5, 6}						
		Low range	t _{CSTL}	—	430	—	ms	
High range	t _{CSTH}	—	4	—				
14		FLL lock time ⁷						
		Low range	t _{Lockl}	—		2	ms	
High range	t _{Lockh}	—		2				
15		FLL frequency unlock range	n _{Unlock}	-4*N		4*N	counts	
16		FLL frequency lock range	n _{Lock}	-2*N		2*N	counts	
17		ICGOUT period jitter, ⁸ measured at f _{ICGOUT} Max Long term jitter (averaged over 2 ms interval)	C _{Jitter}	—		0.2	% f _{ICG}	
18		Internal oscillator deviation from trimmed frequency ⁹						
		V _{DD} = 2.7 – 5.5 V, (constant temperature) V _{DD} = 5.0 V ±10%, -40° C to 125°C	ACC _{int}	—	±0.5	±2	%	
			—	±0.5	±2			

¹ Typical values are based on characterization data at V_{DD} = 5.0V, 25°C unless otherwise stated.

² Self-clocked mode frequency is the frequency that the DCO generates when the FLL is open-loop.

- 3 Loss of reference frequency is the reference frequency detected internally, which transitions the ICG into self-clocked mode if it is not in the desired range.
- 4 Loss of DCO frequency is the DCO frequency detected internally, which transitions the ICG into FLL bypassed external mode (if an external reference exists) if it is not in the desired range.
- 5 This parameter is characterized before qualification rather than 100% tested.
- 6 Proper PC board layout procedures must be followed to achieve specifications.
- 7 This specification applies to the period of time required for the FLL to lock after entering FLL engaged internal or external modes. If a crystal/resonator is being used as the reference, this specification assumes it is already running.
- 8 Jitter is the average deviation from the programmed frequency measured over the specified interval at maximum f_{ICGOUT} . Measurements are made with the device powered by filtered supplies and clocked by a stable external clock signal. Noise injected into the FLL circuitry via V_{DDA} and V_{SSA} and variation in crystal oscillator frequency increase the C_{Jitter} percentage for a given interval.
- 9 See [Figure 3-9](#)

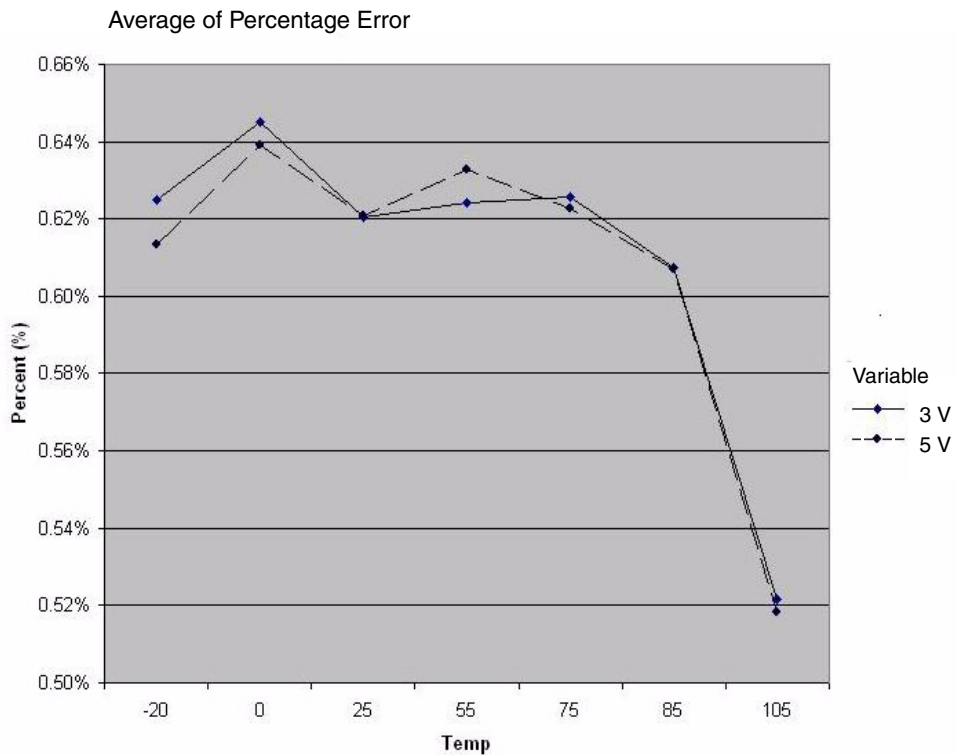

Figure 3-9. Internal Oscillator Deviation from Trimmed Frequency

3.10 AC Characteristics

This section describes ac timing characteristics for each peripheral system.

3.10.1 Control Timing

Table 3-12. Control Timing

Num	C	Parameter	Symbol	Min	Typ ¹	Max	Unit
1		Bus frequency ($t_{cyc} = 1/f_{Bus}$)	f_{Bus}	dc	—	20	MHz
2		Real-time interrupt internal oscillator period	t_{RTI}	600		1500	μs
3		External reset pulse width ² ($t_{cyc} = 1/f_{Self_reset}$)	t_{extrst}	1.5 x t_{Self_reset}		—	ns
4		Reset low drive ³	t_{rstdrv}	34 x t_{cyc}		—	ns
5		Active background debug mode latch setup time	t_{MSSU}	25		—	ns
6		Active background debug mode latch hold time	t_{MSH}	25		—	ns
7		IRQ pulse width Asynchronous path ² Synchronous path ⁴	t_{LIH}, t_{HIL}	100 1.5 x t_{cyc}	—	—	ns
8		KBIPx pulse width Asynchronous path ² Synchronous path ³	t_{LIH}, t_{HIL}	100 1.5 x t_{cyc}	—	—	ns
9		Port rise and fall time (load = 50 pF) ⁵ Slew rate control disabled (PTxSE = 0) Slew rate control enabled (PTxSE = 1)	t_{Rise}, t_{Fall}	— —	3 30		ns

¹ Typical values are based on characterization data at $V_{DD} = 5.0V$, 25°C unless otherwise stated.

² This is the shortest pulse that is guaranteed to be recognized as a reset pin request. Shorter pulses are not guaranteed to override reset requests from internal sources.

³ When any reset is initiated, internal circuitry drives the reset pin low for about 34 bus cycles and then samples the level on the reset pin about 38 bus cycles later to distinguish external reset requests from internal requests.

⁴ This is the minimum pulse width that is guaranteed to pass through the pin synchronization circuitry. Shorter pulses may or may not be recognized. In stop mode, the synchronizer is bypassed so shorter pulses can be recognized in that case.

⁵ Timing is shown with respect to 20% V_{DD} and 80% V_{DD} levels. Temperature range -40°C to 125°C.

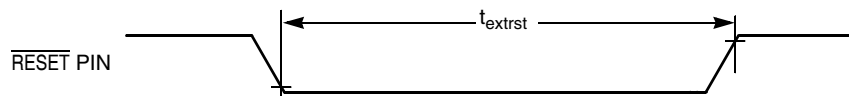

Figure 3-10. Reset Timing

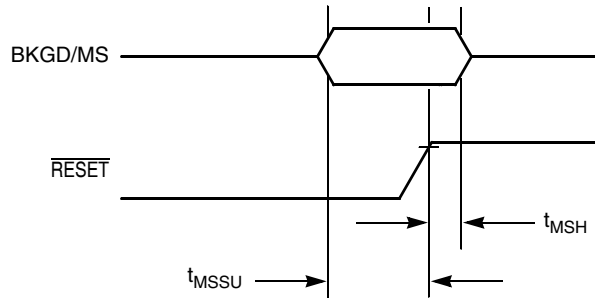

Figure 3-11. Active Background Debug Mode Latch Timing

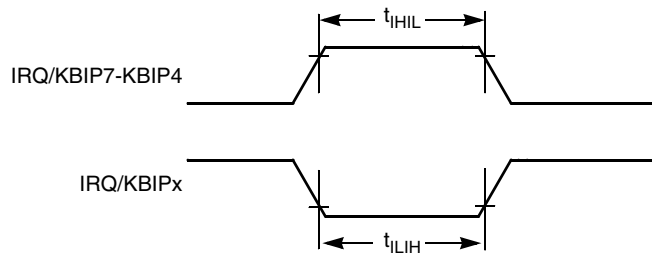

Figure 3-12. IRQ/KBIPx Timing

3.10.2 Timer/PWM (TPM) Module Timing

Synchronizer circuits determine the shortest input pulses that can be recognized or the fastest clock that can be used as the optional external source to the timer counter. These synchronizers operate from the current bus rate clock.

Table 3-13. TPM Input Timing

Function	Symbol	Min	Max	Unit
External clock frequency	f_{TPMext}	dc	$f_{Bus}/4$	MHz
External clock period	t_{TPMext}	4	—	t_{cyc}
External clock high time	t_{clkh}	1.5	—	t_{cyc}
External clock low time	t_{clkl}	1.5	—	t_{cyc}
Input capture pulse width	t_{ICPW}	1.5	—	t_{cyc}

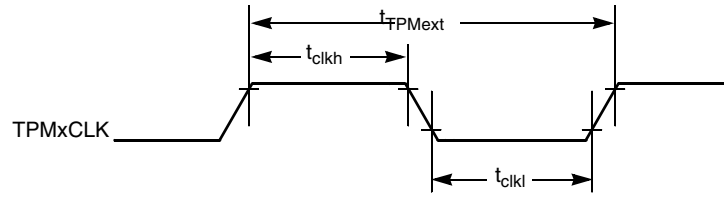

Figure 3-13. Timer External Clock

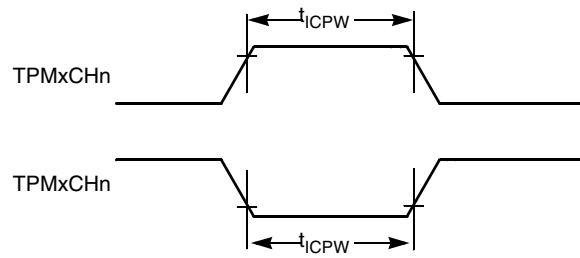

Figure 3-14. Timer Input Capture Pulse

3.11 SPI Characteristics

Table 3-14 and Figure 3-15 through Figure 3-18 describe the timing requirements for the SPI system.

Table 3-14. SPI Electrical Characteristic

Num ¹	C	Characteristic ²	Symbol	Min	Max	Unit
		Operating frequency ³				
		Master	f_{op}	$f_{Bus}/2048$	$f_{Bus}/2$	Hz
		Slave	f_{op}	dc	$f_{Bus}/4$	
1		Cycle time				
		Master	t_{SCK}	2	2048	t_{cyc}
		Slave	t_{SCK}	4	—	t_{cyc}
2		Enable lead time				
		Master	t_{Lead}	—	1/2	t_{SCK}
		Slave	t_{Lead}	1/2	—	t_{SCK}
3		Enable lag time				
		Master	t_{Lag}	—	1/2	t_{SCK}
		Slave	t_{Lag}	1/2	—	t_{SCK}
4		Clock (SPSCK) high time Master and Slave	t_{SCKH}	$1/2 t_{SCK} - 25$	—	ns
5		Clock (SPSCK) low time Master and Slave	t_{SCKL}	$1/2 t_{SCK} - 25$	—	ns
6		Data setup time (inputs)				
		Master	$t_{SI(M)}$	30	—	ns
		Slave	$t_{SI(S)}$	30	—	ns
7		Data hold time (inputs)				
		Master	$t_{HI(M)}$	30	—	ns
		Slave	$t_{HI(S)}$	30	—	ns
8		Access time, slave ⁴	t_A	0	40	ns
9		Disable time, slave ⁵	t_{dis}	—	40	ns
10		Data setup time (outputs)				
		Master	t_{SO}	25	—	ns
		Slave	t_{SO}	25	—	ns
11		Data hold time (outputs)				
		Master	t_{HO}	-10	—	ns
		Slave	t_{HO}	-10	—	ns

¹ Refer to Figure 3-15 through Figure 3-18.

² All timing is shown with respect to 20% V_{DD} and 70% V_{DD} , unless noted; 100 pF load on all SPI pins. All timing assumes slew rate control disabled and high drive strength enabled for SPI output pins.

³ Maximum baud rate must be limited to 5 MHz due to pad input characteristics.

⁴ Time to data active from high-impedance state.

⁵ Hold time to high-impedance state.

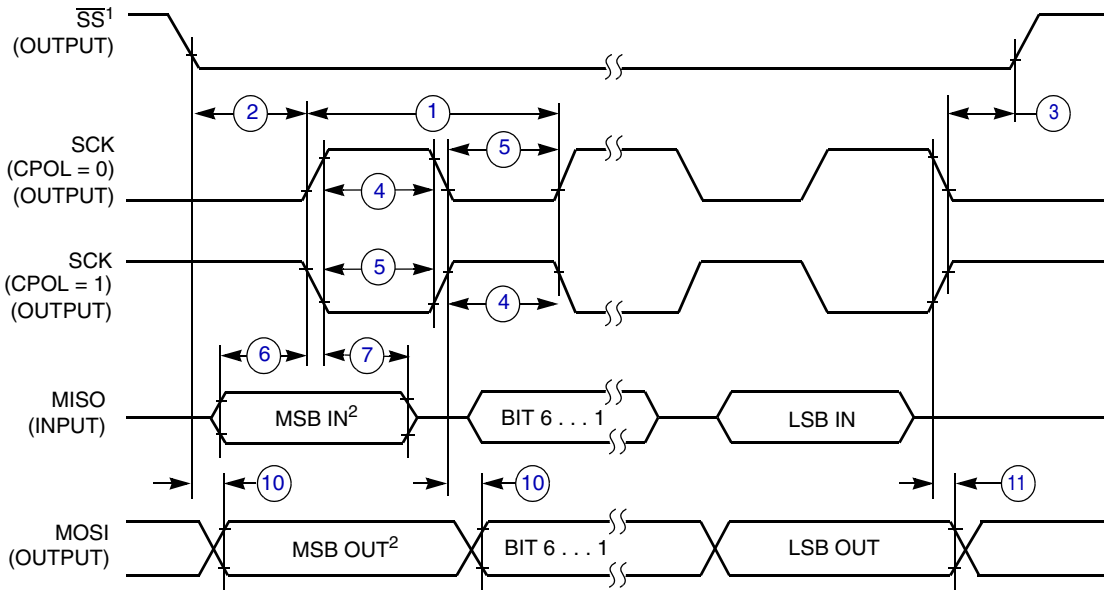

NOTES:

1. \overline{SS} output mode (MODFEN = 1, SSOE = 1).
2. LSBF = 0. For LSBF = 1, bit order is LSB, bit 1, ..., bit 6, MSB.

Figure 3-15. SPI Master Timing (CPHA = 0)

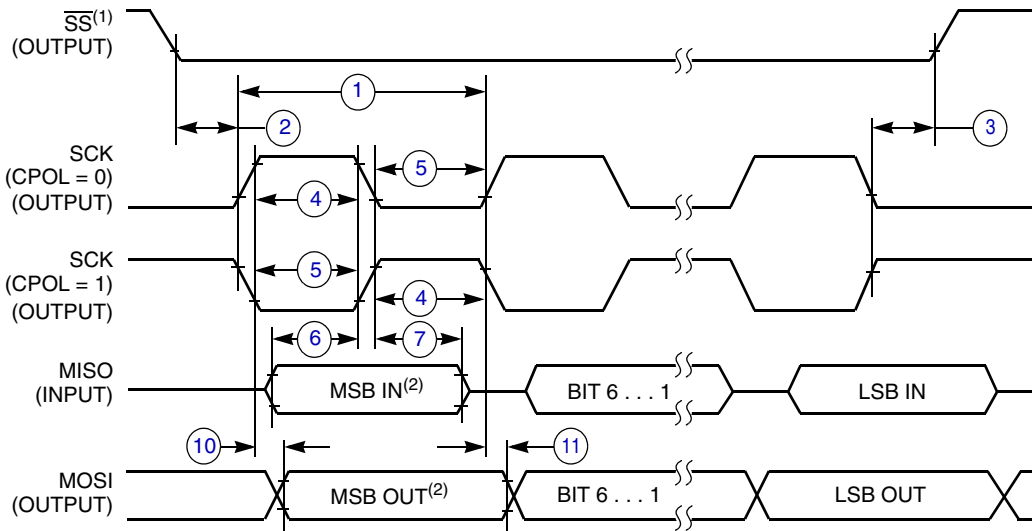

NOTES:

1. \overline{SS} output mode (MODFEN = 1, SSOE = 1).
2. LSBF = 0. For LSBF = 1, bit order is LSB, bit 1, ..., bit 6, MSB.

Figure 3-16. SPI Master Timing (CPHA = 1)

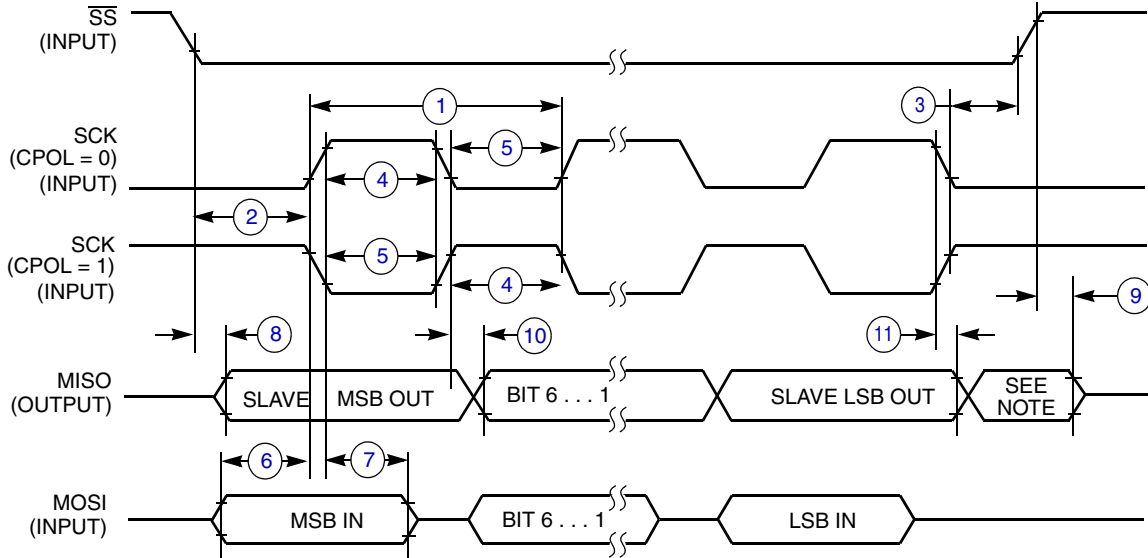

NOTE:

- 1. Not defined but normally MSB of character just received

Figure 3-17. SPI Slave Timing (CPHA = 0)

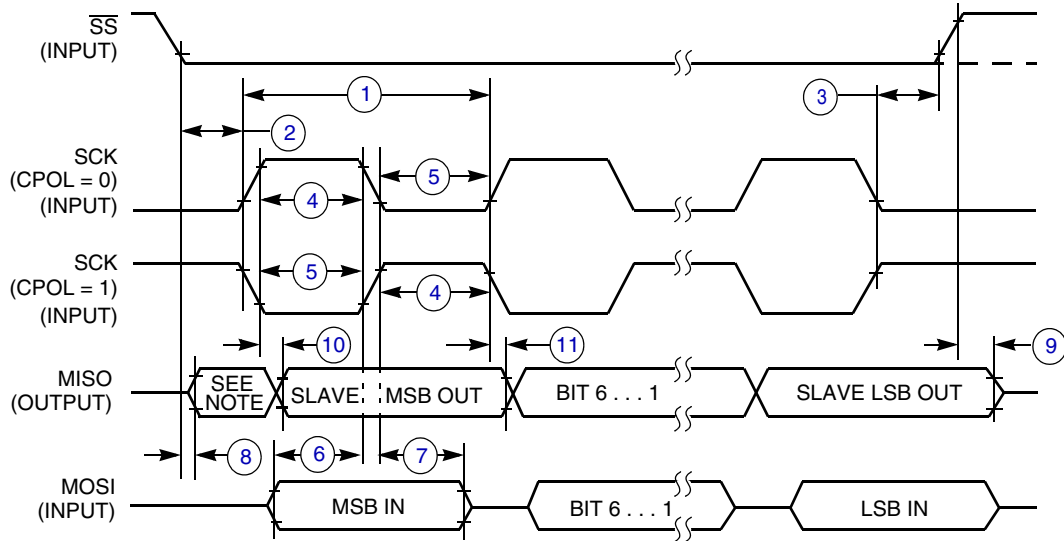

NOTE:

- 1. Not defined but normally LSB of character just received

Figure 3-18. SPI Slave Timing (CPHA = 1)

3.12 FLASH Specifications

This section provides details about program/erase times and program-erase endurance for the Flash memory.

Program and erase operations do not require any special power sources other than the normal V_{DD} supply.

Table 3-15. Flash Characteristics

Num	C	Characteristic	Symbol	Min	Typ ¹	Max	Unit
1	P	Supply voltage for program/erase	$V_{\text{prog/erase}}$	2.7		5.5	V
2	P	Supply voltage for read operation	V_{Read}	2.7		5.5	V
3	P	Internal FCLK frequency ²	f_{FCLK}	150		200	kHz
4	P	Internal FCLK period (1/FCLK)	t_{Fcy}^2	5		6.67	μs
5	P	Byte program time (random location) ⁽²⁾	t_{prog}	9			t_{Fcy}
6	C	Byte program time (burst mode) ⁽²⁾	t_{Burst}	4			t_{Fcy}
7	P	Page erase time ³	t_{Page}	4000			t_{Fcy}
8	P	Mass erase time ⁽²⁾	t_{Mass}	20,000			t_{Fcy}
9	C	Program/erase endurance ⁴ T_L to $T_H = -40^\circ\text{C}$ to $+125^\circ\text{C}$ $T = 25^\circ\text{C}$		10,000 —	— 100,000	— —	cycles
10	C	Data retention ⁵	$t_{\text{D-ret}}$	15	100	—	years

¹ Typical values are based on characterization data at $V_{DD} = 5.0\text{ V}$, 25°C unless otherwise stated.

² The frequency of this clock is controlled by a software setting.

³ These values are hardware state machine controlled. User code does not need to count cycles. This information supplied for calculating approximate time to program and erase.

⁴ **Typical endurance for Flash** was evaluated for this product family on the 9S12Dx64. For additional information on how Freescale Semiconductor defines typical endurance, please refer to Engineering Bulletin EB619/D, *Typical Endurance for Nonvolatile Memory*.

⁵ **Typical data retention** values are based on intrinsic capability of the technology measured at high temperature and de-rated to 25°C using the Arrhenius equation. For additional information on how Freescale Semiconductor defines typical data retention, please refer to Engineering Bulletin EB618/D, *Typical Data Retention for Nonvolatile Memory*.

3.13 EMC Performance

Electromagnetic compatibility (EMC) performance is highly dependant on the environment in which the MCU resides. Board design and layout, circuit topology choices, location and characteristics of external components as well as MCU software operation all play a significant role in EMC performance. The system designer should consult Freescale applications notes such as AN2321, AN1050, AN1263, AN2764, and AN1259 for advice and guidance specifically targeted at optimizing EMC performance.

3.13.1 Radiated Emissions

Microcontroller radiated RF emissions are measured from 150 kHz to 1 GHz using the TEM/GTEM Cell method in accordance with the IEC 61967-2 and SAE J1752/3 standards. The measurement is performed with the microcontroller installed on a custom EMC evaluation board while running specialized EMC test software. The radiated emissions from the microcontroller are measured in a TEM cell in two package orientations (North and East). For more detailed information concerning the evaluation results, conditions and setup, please refer to the EMC Evaluation Report for this device.

The maximum radiated RF emissions of the tested configuration in all orientations are less than or equal to the reported emissions levels.

Table 3-16. Radiated Emissions

Parameter	Symbol	Conditions	Frequency	f_{osc}/f_{BUS}	Level ¹ (Max)	Unit
Radiated emissions, electric field and magnetic field	V_{RE_TEM}	$V_{DD} = 5.0 V$ $T_A = +25^{\circ}C$ package type 80 LQFP	0.15 – 50 MHz	32kHz crystal 20MHz Bus	30	dB μ V
			50 – 150 MHz		32	
			150 – 500 MHz		19	
			500 – 1000 MHz		7	
			IEC Level		I^2	—
			SAE Level		I^2	—

¹ Data based on laboratory test results.

² IEC and SAE Level Maximums: $I=36$ dBuV.

Chapter 4

Ordering Information and Mechanical Drawings

4.1 Ordering Information

This section contains ordering numbers for MC9S08AC128 Series devices. See below for an example of the device numbering system.

Table 4-1. Device Numbering System

Device Number	Memory		Available Packages ¹
	FLASH	RAM	Type
MC9S08AC128	128K	8K	80 LQFP, 64 QFP, 48-QFN, 44-LQFP
MC9S08AC96	96K	6K	80 LQFP, 64 QFP, 48-QFN, 44-LQFP

¹ See Table 4-2 for package information.

4.2 Orderable Part Numbering System

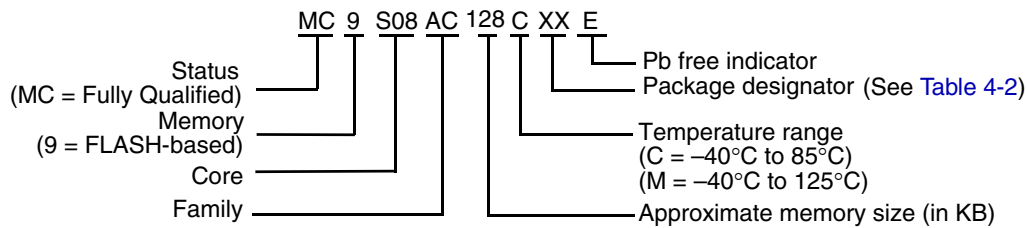

4.3 Mechanical Drawings

Table 4-2 provides the available package types and their document numbers. The latest package outline/mechanical drawings are available on the MC9S08AC128 Series Product Summary pages at <http://www.freescale.com>.

To view the latest drawing, either:

- Click on the appropriate link in Table 4-2, or
- Open a browser to the Freescale® website (<http://www.freescale.com>), and enter the appropriate document number (from Table 4-2) in the “Enter Keyword” search box at the top of the page.

Table 4-2. Package Information

Pin Count	Type	Designator	Document No.
80	LQFP	LK	98ASS23237W
64	QFP	FU	98ASB42844B
48	QFN	FT	98ARH99048A
44	LQFP	FG	98ASS23225W

Chapter 5

Revision History

To provide the most up-to-date information, the version of our documents on the World Wide Web will be the most current. Your printed copy may be an earlier revision. To verify you have the latest information available, refer to:

<http://freescale.com/>

The following revision history table summarizes changes contained in this document.

Revision Number	Revision Date	Description of Changes
1	9/2008	Initial release of a separate data sheet and reference manual. Removed PTH7, clarified SPI as one full and one master-only, added missing RoHS logo, updated back cover addresses, and incorporated general release edits and updates. Added some finalized electrical characteristics.
2	6/2009	Added the parameter “Bandgap Voltage Reference” in Table 3-6 Updated Section 3.13, “EMC Performance” and corrected Table 3-16 . Updated disclaimer page.
3	9/2010	Added 48-pin QFN package information.
4	8/2011	Updated the t_{RTI} in the Table 3-12 . Updated the R_{IDD} in the Table 3-7 .

How to Reach Us:

Home Page:

www.freescale.com

Web Support:

<http://www.freescale.com/support>

USA/Europe or Locations Not Listed:

Freescale Semiconductor, Inc.
Technical Information Center, EL516
2100 East Elliot Road
Tempe, Arizona 85284
1-800-521-6274 or +1-480-768-2130
www.freescale.com/support

Europe, Middle East, and Africa:

Freescale Halbleiter Deutschland GmbH
Technical Information Center
Schatzbogen 7
81829 Muenchen, Germany
+44 1296 380 456 (English)
+46 8 52200080 (English)
+49 89 92103 559 (German)
+33 1 69 35 48 48 (French)
www.freescale.com/support

Japan:

Freescale Semiconductor Japan Ltd.
Headquarters
ARCO Tower 15F
1-8-1, Shimo-Meguro, Meguro-ku,
Tokyo 153-0064
Japan
0120 191014 or +81 3 5437 9125
support.japan@freescale.com

Asia/Pacific:

Freescale Semiconductor China Ltd.
Exchange Building 23F
No. 118 Jianguo Road
Chaoyang District
Beijing 100022
China
+86 10 5879 8000
support.asia@freescale.com

For Literature Requests Only:

Freescale Semiconductor Literature Distribution
Center
1-800-441-2447 or +1-303-675-2140
Fax: +1-303-675-2150
LDCForFreescaleSemiconductor@hibbert-group.com

Information in this document is provided solely to enable system and software implementers to use Freescale Semiconductor products. There are no express or implied copyright licenses granted hereunder to design or fabricate any integrated circuits or integrated circuits based on the information in this document.

Freescale Semiconductor reserves the right to make changes without further notice to any products herein. Freescale Semiconductor makes no warranty, representation or guarantee regarding the suitability of its products for any particular purpose, nor does Freescale Semiconductor assume any liability arising out of the application or use of any product or circuit, and specifically disclaims any and all liability, including without limitation consequential or incidental damages. "Typical" parameters which may be provided in Freescale Semiconductor data sheets and/or specifications can and do vary in different applications and actual performance may vary over time. All operating parameters, including "Typicals" must be validated for each customer application by customer's technical experts. Freescale Semiconductor does not convey any license under its patent rights nor the rights of others. Freescale Semiconductor products are not designed, intended, or authorized for use as components in systems intended for surgical implant into the body, or other applications intended to support or sustain life, or for any other application in which the failure of the Freescale Semiconductor product could create a situation where personal injury or death may occur. Should Buyer purchase or use Freescale Semiconductor products for any such unintended or unauthorized application, Buyer shall indemnify and hold Freescale Semiconductor and its officers, employees, subsidiaries, affiliates, and distributors harmless against all claims, costs, damages, and expenses, and reasonable attorney fees arising out of, directly or indirectly, any claim of personal injury or death associated with such unintended or unauthorized use, even if such claim alleges that Freescale Semiconductor was negligent regarding the design or manufacture of the part.

Freescale™ and the Freescale logo are trademarks of Freescale Semiconductor,



Freescale™ and the Freescale logo are trademarks of Freescale Semiconductor, Inc. All other product or service names are the property of their respective owners.

© Freescale Semiconductor, Inc. 2009. All rights reserved.